

EMC TEST REPORT

Applicant	Particle Industries, Inc
Address	325 9th Street, San Francisco, CA 94103, United States Of America

Manufacturer or Supplier	Particle Industries, Inc
Address	325 9th Street, San Francisco, CA 94103, United States Of America
Product	M SoM
Brand Name	Particle
Model Name	M524
Date of tests	Dec. 27, 2023 ~ Feb. 18, 2024

The submitted sample of the above equipment has been tested according to the requirements of the following standards:

- EN 301 489-1 V2.2.3 (2019-11)
- EN 301 489-3 V2.3.2 (2023-01)
- Draft EN 301 489-17 V3.2.6 (2023-06)
- EN 301 489-19 V2.2.1 (2022-09)
- EN 301 489-52 V1.2.1 (2021-11)

CONCLUSION: The submitted sample was found to COMPLY with the test requirement

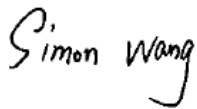
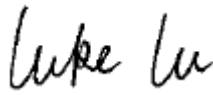
Prepared by Simon Wang Engineer / Mobile Department	Approved by Luke Lu Manager / Mobile Department
	
Date: Feb. 18, 2024	Date: Feb. 18, 2024

This report is governed by, and incorporates by reference, the Conditions of Testing as posted at the date of issuance of this report at <http://www.bureauveritas.com/home/about-us/our-business/cps/about-us/terms-conditions/> and is intended for your exclusive use. Any copying or replication of this report to or for any other person or entity, or use of our name or trademark, is permitted only with our prior written permission. This report sets forth our findings solely with respect to the test samples identified herein. The results set forth in this report are not indicative or representative of the quality or characteristics of the lot from which a test sample was taken or any similar or identical product unless specifically and expressly noted. Our report includes all of the tests requested by you and the results thereof based upon the information that you provided to us. Measurement uncertainty is only provided upon request for accredited tests. Statements of conformity are based on simple acceptance criteria without taking measurement uncertainty into account, unless otherwise requested in writing. You have 60 days from date of issuance of this report to notify us of any material error or omission caused by our negligence or if you require measurement uncertainty; provided, however, that such notice shall be in writing and shall specifically address the issue you wish to raise. A failure to raise such issue within the prescribed time shall constitute your unqualified acceptance of the completeness of this report, the tests conducted and the correctness of the report contents.



TABLE OF CONTENTS

- RELEASE CONTROL RECORD 4**
- 1 SUMMARY OF TEST RESULTS 5**
 - 1.1 MEASUREMENT UNCERTAINTY 7
- 2 GENERAL INFORMATION 8**
 - 2.1 GENERAL DESCRIPTION OF EUT 8
 - 2.2 DESCRIPTION OF TEST MODES 10
 - 2.3 TEST PROGRAM USED AND OPERATION DESCRIPTION 13
 - 2.4 PRIMARY CLOCK FREQUENCIES OF INTERNAL SOURCE 13
 - 2.5 CONFIGURATION OF SYSTEM UNDER TEST 14
 - 2.6 DESCRIPTION OF SUPPORT UNIT 16
- 3 EMISSION TEST 17**
 - 3.1 CONDUCTED EMISSION MEASUREMENT AT MAINS PORTS 17
 - 3.1.1 LIMITS OF CONDUCTED EMISSION MEASUREMENT17
 - 3.1.2 TEST INSTRUMENTS17
 - 3.1.3 TEST PROCEDURE18
 - 3.1.4 DEVIATION FROM TEST STANDARD19
 - 3.1.5 TEST SETUP19
 - 3.1.6 EUT OPERATING CONDITIONS19
 - 3.1.7 TEST RESULTS20
 - 3.2 RADIATED DISTURBANCE MEASUREMENT 22
 - 3.2.1 LIMITS OF RADIATED EMISSION MEASUREMENT22
 - 3.2.2 TEST INSTRUMENTS23
 - 3.2.3 TEST PROCEDURE24
 - 3.2.4 DEVIATION FROM TEST STANDARD25
 - 3.2.5 TEST SETUP26
 - 3.2.6 EUT OPERATING CONDITIONS26
 - 3.2.7 TEST RESULTS27
 - 3.3 HARMONICS CURRENT MEASUREMENT 30
 - 3.3.1 LIMITS OF HARMONICS CURRENT MEASUREMENT30
 - 3.3.2 TEST PROCEDURE31
 - 3.3.3 DEVIATION FROM TEST STANDARD32
 - 3.3.4 TEST SETUP32
 - 3.3.5 TEST RESULTS32
 - 3.4 VOLTAGE FLUCTUATION AND FLICKS MEASUREMENT 33
 - 3.4.1 TEST INSTRUMENTS33
 - 3.4.2 LIMITS OF VOLTAGE FLUCTUATION AND FLICKS MEASUREMENT33
 - 3.4.3 TEST PROCEDURE33
 - 3.4.4 DEVIATION FROM TEST STANDARD34
 - 3.4.5 TEST SETUP34
 - 3.4.6 TEST RESULTS34
- 4 IMMUNITY TEST 35**
 - 4.1 GENERAL DESCRIPTION 35
 - 4.2 PERFORMANCE CRITERIA 37
 - 4.3 ELECTROSTATIC DISCHARGE IMMUNITY TEST (ESD) 43
 - 4.3.1 TEST SPECIFICATION43
 - 4.3.2 TEST INSTRUMENT43
 - 4.3.3 TEST PROCEDURE44



4.3.4	DEVIATION FROM TEST STANDARD	44
4.3.5	TEST SETUP	45
4.3.6	TEST RESULTS	46
4.4	RADIATED, RADIO-FREQUENCY, ELECTROMAGNETIC FIELD IMMUNITY TEST (RS)....	47
4.4.1	TEST SPECIFICATION	47
4.4.2	TEST INSTRUMENT	47
4.4.3	TEST PROCEDURE	48
4.4.4	DEVIATION FROM TEST STANDARD	48
4.4.5	TEST SETUP	48
4.4.6	TEST RESULTS	49
4.4.7	DATA TRANSFER MEASUREMENT RESULTS	53
4.5	ELECTRICAL FAST TRANSIENT (EFT)	55
4.5.1	TEST SPECIFICATION	55
4.5.2	TEST INSTRUMENT	55
4.5.3	TEST PROCEDURE	56
4.5.4	DEVIATION FROM TEST STANDARD	57
4.5.5	TEST SETUP	57
4.5.6	TEST RESULTS	58
4.6	SURGE IMMUNITY	59
4.6.1	TEST SPECIFICATION	59
4.6.2	TEST INSTRUMENT	59
4.6.3	TEST PROCEDURE	60
4.6.4	DEVIATION FROM TEST STANDARD	61
4.6.5	TEST SETUP	61
4.6.6	TEST RESULTS	62
4.7	CONDUCTED RADIO FREQUENCY DISTURBANCES (CS)	63
4.7.1	TEST SPECIFICATION	63
4.7.2	TEST INSTRUMENT	63
4.7.3	TEST PROCEDURE	65
4.7.4	DEVIATION FROM TEST STANDARD	65
4.7.5	TEST SETUP	66
4.7.6	TEST RESULTS	67
4.7.7	DATA TRANSFER MEASUREMENT RESULTS	70
4.8	VOLTAGE DIP/SHORT INTERRUPTIONS/VOLTAGE VARIATIONS (DIP) IMMUNITY TEST	72
4.8.1	TEST SPECIFICATION	72
4.8.2	TEST INSTRUMENT	72
4.8.3	TEST PROCEDURE	72
4.8.4	DEVIATION FROM TEST STANDARD	72
4.8.5	TEST SETUP	73
4.8.6	TEST RESULTS	74
5	PHOTOGRAPHS OF THE TEST CONFIGURATION	75
6	APPENDIX A – MODIFICATIONS RECORDERS FOR ENGINEERING CHANGES TO THE EUT BY THE LAB	82



**BUREAU
VERITAS**

Test Report No.: W7L-P23120016EM01

RELEASE CONTROL RECORD

ISSUE NO.	REASON FOR CHANGE	DATE ISSUED
W7L-P23120016EM01	Original release	Feb. 18, 2024



1 SUMMARY OF TEST RESULTS

EN 301 489-1 V2.2.3 (2019-11) / EN 301 489-3 V2.3.2 (2023-01)/ Draft EN 301 489-17 V3.2.6 (2023-06) / EN 301 489-19 V2.2.1 (2022-09)/ EN 301 489-52 V1.2.1 (2021-11), Emission				
Clause	Basic Standard	Phenomenon	Application	Result
8.2	EN 55032:2015	Radiated emission 30-1000 MHz	Enclosure of ancillary equipment measured on a standalone basis	Compliance
		Radiated emission 1-6 GHz		Compliance
8.3	EN 55032:2015	Conducted emission 150 kHz- 30 MHz	DC power input/output ports (fixed)	-
		Conducted emission 150 kHz- 30 MHz	DC power input ports(vehicular)	-
8.4	EN 55032:2015	Conducted emission 150 kHz- 30 MHz	AC mains input/ output ports	Compliance
8.5	EN IEC 61000-3-2: 2019+A1:2021	Harmonic current emissions	AC mains input port	-
8.6	EN IEC 61000-3-3: 2013+A2:2021	Voltage fluctuations and flicker	AC mains input ports	Compliance
8.7	EN 55032:2015	Conducted disturbance 150 kHz - 30 MHz	Telecom ports	-

EN 301 489-1 V2.2.3 (2019-11) / EN 301 489-3 V2.3.2 (2023-01)/ Draft EN 301 489-17 V3.2.6 (2023-06)/ EN 301 489-19 V2.2.1 (2022-09)/ EN 301 489-52 V1.2.1 (2021-11), Immunity				
Clause	Basic Standard	Phenomenon	Application	Result
9.2	EN IEC 61000-4-3:2020	RF Electromagnetic Field (80 MHz to 6000) (RS)	Enclosure	Compliance
9.3	EN 61000-4-2:2009	Electrostatic Discharges (ESD)	Enclosure	Compliance
9.4	EN 61000-4-4:2012	Fast Transients Common Mode (EFT)	AC power ports	Compliance
			Telecom ports	-
9.8	EN 61000-4-5:2014+A1:2017	Surge immunity test	AC power ports	Compliance
			Telecom ports	-
9.5	EN 61000-4-6:2014	RF Common Mode 150 kHz to 80 MHz (CS)	AC power ports	Compliance
			Telecom ports	-
9.6	ISO 7637-2:2004	Transients and Surges	DC power input ports (Vehicular)	-



**BUREAU
VERITAS**

Test Report No.: W7L-P23120016EM01

9.7	EN IEC 61000-4-11:2020	Voltage Dips and Interruptions	AC mains power input ports	Compliance
-----	---------------------------	-----------------------------------	----------------------------	------------



1.1 MEASUREMENT UNCERTAINTY

Where relevant, the following measurement uncertainty levels have been estimated for tests performed on the EUT as specified in CISPR 16-4-2:

The listed uncertainties are the worst case uncertainty for the entire range of measurement. Please note that the uncertainty values are provided for informational purposes only and are not used in determining the PASS/FAIL results.

Measurement	Frequency	Uncertainty
Conducted emission	150kHz ~ 30MHz	±2.70dB
Radiated emissions	30MHz ~1000MHz	±4.98dB
	1GHz ~ 6GHz	±4.70dB

This uncertainty represents an expanded uncertainty expressed at approximately the 95% confidence level using a coverage factor of k=2.



2 GENERAL INFORMATION

2.1 GENERAL DESCRIPTION OF EUT

PRODUCT	M SoM	
BRAND NAME	Particle	
MODEL NAME	M524	
NOMINAL VOLTAGE	VCC: 3.8V. 3V3:3.3V	
MODULATION TYPE	BT_LE	GFSK
	WLAN	DSSS, OFDM
	GPS/GALILEO/GLONASS/BDS	BPSK
	GSM/GPRS/EDGE	GMSK, 8PSK
	WCDMA	BPSK/QPSK
	LTE	QPSK/16QAM
OPERATING FREQUENCY	WLAN	2412 ~ 2472MHz for 11b/g/n(HT20/HT40) 5180 ~ 5240MHz, 5260 ~ 5320MHz, 5500 ~ 5700MHz, 5745 ~ 5825MHz for 11a/ n(HT20) / n(HT40)
	BT_LE	2402MHz ~ 2480MHz
	GPS/GALILEO/GLONASS/BDS	1559MHz ~ 1610MHz
	GSM	880.2MHz ~ 914.8MHz (FOR GSM 900) 1710.2MHz ~ 1784.8MHz (FOR DCS 1800)
	WCDMA	1922.4MHz~ 1977.6MHz (FOR WCDMA Band 1) 882.4MHZ ~ 912.6MHZ (FOR WCDMA Band 8)
	LTE	1922.5MHz~ 1977.5MHz (FOR LTE Band1) 1710.7MHz ~ 1784.3MHz (FOR LTE Band3) 2502.5MHz~ 2567.5MHz (FOR LTE Band7) 880.7MHz ~ 914.3MHz (FOR LTE Band8) 834.5MHz~ 859.5MHz (FOR LTE Band20) 704.5MHz ~ 746.5MHz (FOR LTE Band28)
HW VERSION	V0.2	
SW VERSION	EG91EXGAR08A14M1G	
I/O PORTS	Refer to user's manual	
CABLE SUPPLIED	N/A	



**BUREAU
VERITAS**

Test Report No.: W7L-P23120016EM01

NOTE:

1. For a more detailed features description, please refer to the manufacturer's specifications or the user's manual.
2. For the test results, the EUT had been tested with all conditions. But only the worst case was shown in the test report.



2.2 DESCRIPTION OF TEST MODES

For Radiated Emission evaluation, the worst data was found at **230Vac/50Hz** and recorded in the applied test report.

For Conducted Emission evaluation, the worst data was found at **230Vac/50Hz** and recorded in the applied test report.

Test Mode	Test Condition
Radiated emission test	
1	GSM 900 Link+Adapter+USB Cable+WIFI Link+GPS RX+Battery
2	GSM 1800 Link+Adapter+USB Cable+BT Link+GLONASS RX+Battery
3	WCDMA B1 Link+Adapter+USB Cable+WIFI Link+GPS RX+Battery
4	WCDMA B8 Link+Adapter+USB Cable+BT Link+GLONASS RX+Battery
5	LTE B1 Link+Adapter+USB Cable+WIFI Link+GALILEO RX+Battery
6	LTE B3 Link+Adapter+USB Cable+BT Link+BeiDou RX+Battery
7	LTE B7 Link+Adapter+USB Cable+WIFI Link+GPS RX+Battery
8	LTE B8 Link+Adapter+USB Cable+BT Link+GLONASS RX+Battery
9	LTE B20 Link+Adapter+USB Cable+WIFI Link+GALILEO RX+Battery
10	LTE B28 Link+Adapter+USB Cable+BT Link+BeiDou RX+Battery
11	GSM 900 Idle+Adapter+USB Cable+WIFI Idle+GPS RX+Battery
12	WCDMA B8 Idle+Adapter+USB Cable+BT Idle+GALILEO RX+Battery
13	LTE B1 Idle+Adapter+USB Cable+BT Idle+GALILEO RX+Battery

Conducted emission test	
1	GSM 900 Link+Adapter+USB Cable+WIFI Link+GPS RX+Battery
2	GSM 1800 Link+Adapter+USB Cable+BT Link+GLONASS RX+Battery
3	WCDMA B1 Link+Adapter+USB Cable+WIFI Link+GPS RX+Battery
4	WCDMA B8 Link+Adapter+USB Cable+BT Link+GLONASS RX+Battery
5	LTE B1 Link+Adapter+USB Cable+WIFI Link+GALILEO RX+Battery
6	LTE B3 Link+Adapter+USB Cable+BT Link+BeiDou RX+Battery
7	LTE B7 Link+Adapter+USB Cable+WIFI Link+GPS RX+Battery
8	LTE B8 Link+Adapter+USB Cable+BT Link+GLONASS RX+Battery
9	LTE B20 Link+Adapter+USB Cable+WIFI Link+GALILEO RX+Battery
10	LTE B28 Link+Adapter+USB Cable+BT Link+BeiDou RX+Battery
11	GSM 900 Idle+Adapter+USB Cable+WIFI Idle+GPS RX+Battery
12	WCDMA B8 Idle+Adapter+USB Cable+BT Idle+GALILEO RX+Battery
13	LTE B1 Idle+Adapter+USB Cable+BT Idle+GALILEO RX+Battery



NOTE:

1. For conducted emission test, test mode 1 was the worst case and only this mode was presented in this report.
2. For radiated emission test, test mode 13 was the worst case and only this mode was presented in this report.

Test Mode	Test Condition
ESD test	
1	GSM 900 Link+Adapter+USB Cable+WIFI Link+GPS RX+Battery
2	GSM 1800 Link+Adapter+USB Cable+BT Link+GLONASS RX+Battery
3	WCDMA B1 Link+Adapter+USB Cable+WIFI Link+GPS RX+Battery
4	WCDMA B8 Link+Adapter+USB Cable+BT Link+GLONASS RX+Battery
5	LTE B1 Link+Adapter+USB Cable+WIFI Link+GALILEO RX+Battery
6	LTE B3 Link+Adapter+USB Cable+BT Link+BeiDou RX+Battery
7	LTE B7 Link+Adapter+USB Cable+WIFI Link+GPS RX+Battery
8	LTE B8 Link+Adapter+USB Cable+BT Link+GLONASS RX+Battery
9	LTE B20 Link+Adapter+USB Cable+WIFI Link+GALILEO RX+Battery
10	LTE B28 Link+Adapter+USB Cable+BT Link+BeiDou RX+Battery
11	GSM 900 Idle+Adapter+USB Cable+WIFI Idle+GPS RX+Battery
12	WCDMA B8 Idle+Adapter+USB Cable+BT Idle+GALILEO RX+Battery
13	LTE B1 Idle+Adapter+USB Cable+BT Idle+GALILEO RX+Battery

CS test	
1	GSM 900 Link+Adapter+USB Cable+Battery
2	GSM 1800 Link+Adapter+USB Cable+Battery
3	WCDMA B1 Link+Adapter+USB Cable+Battery+BER
4	WCDMA B8 Link+Adapter+USB Cable+Battery+BER
5	LTE B1 Link+Adapter+USB Cable+Battery+Throughput
6	LTE B3 Link+Adapter+USB Cable+Battery+Throughput
7	LTE B7 Link+Adapter+USB Cable+Battery+Throughput
8	LTE B8 Link+Adapter+USB Cable+Battery+Throughput
9	LTE B20 Link+Adapter+USB Cable+Battery+Throughput
10	LTE B28 Link+Adapter+USB Cable+Battery+Throughput
11	GSM 900 Idle+Adapter+USB Cable+WIFI Link+GPS RX+Battery
12	GSM 1800 Idle+Adapter+USB Cable+BT Link+GLONASS RX+Battery
13	LTE B1 Idle+Adapter+USB Cable+WIFI Idle+GALILEO RX+Battery
14	LTE B3 Idle+Adapter+USB Cable+BT Idle+BeiDou RX+Battery
15	WCDMA B8 Idle+Adapter+USB Cable+BT Idle+BeiDou RX+Battery



RS test	
1	GSM 900 Link+Adapter+USB Cable+Battery
2	GSM 1800 Link+Adapter+USB Cable+Battery
3	WCDMA B1 Link+Adapter+USB Cable+Battery+BER
4	WCDMA B8 Link+Adapter+USB Cable+Battery+BER
5	LTE B1 Link+Adapter+USB Cable+Battery+Throughput
6	LTE B3 Link+Adapter+USB Cable+Battery+Throughput
7	LTE B7 Link+Adapter+USB Cable+Battery+Throughput
8	LTE B8 Link+Adapter+USB Cable+Battery+Throughput
9	LTE B20 Link+Adapter+USB Cable+Battery+Throughput
10	LTE B28 Link+Adapter+USB Cable+Battery+Throughput
11	GSM 900 Idle+Adapter+USB Cable+WIFI Link+GPS RX+Battery
12	GSM 1800 Idle+Adapter+USB Cable+BT Link+GLONASS RX+Battery
13	LTE B1 Idle+Adapter+USB Cable+WIFI Idle+GALILEO RX+Battery
14	LTE B3 Idle+Adapter+USB Cable+BT Idle+BeiDou RX+Battery
15	WCDMA B8 Idle+Adapter+USB Cable+BT Idle+BeiDou RX+Battery

EFT, Surge, Dip tests	
1	GSM 900 Link+Adapter+USB Cable+WIFI Link+GPS RX+Battery
2	GSM 1800 Link+Adapter+USB Cable+BT Link+GLONASS RX+Battery
3	WCDMA B1 Link+Adapter+USB Cable+WIFI Link+GPS RX+Battery
4	WCDMA B8 Link+Adapter+USB Cable+BT Link+GLONASS RX+Battery
5	LTE B1 Link+Adapter+USB Cable+WIFI Link+GALILEO RX+Battery
6	LTE B3 Link+Adapter+USB Cable+BT Link+BeiDou RX+Battery
7	LTE B7 Link+Adapter+USB Cable+WIFI Link+GPS RX+Battery
8	LTE B8 Link+Adapter+USB Cable+BT Link+GLONASS RX+Battery
9	LTE B20 Link+Adapter+USB Cable+WIFI Link+GALILEO RX+Battery
10	LTE B28 Link+Adapter+USB Cable+BT Link+BeiDou RX+Battery
11	GSM 900 Idle+Adapter+USB Cable+WIFI Idle+GPS RX+Battery
12	WCDMA B8 Idle+Adapter+USB Cable+BT Idle+GALILEO RX+Battery
13	LTE B1 Idle+Adapter+USB Cable+BT Idle+GALILEO RX+Battery



2.3 TEST PROGRAM USED AND OPERATION DESCRIPTION

<Emission Tests>

- a. The EUT was charged from the adapter when the mode was tested.
- b. The EUT Linked with Bluetooth
- c. The EUT connected with Wireless AP
- d. The EUT connected with CMW500.

<Immunity Tests>

- a. The EUT was charged from the adapter when the mode was tested.
- b. The EUT Linked with Bluetooth
- c. The EUT connected with Wireless AP
- d. The EUT connected with CMW500.

2.4 PRIMARY CLOCK FREQUENCIES OF INTERNAL SOURCE

The highest frequency generated or used within the EUT or on which the EUT operates or tunes is 5825 MHz, provided by the manufacturer, for detailed internal source, please refer to the manufacturer's specifications.



2.5 CONFIGURATION OF SYSTEM UNDER TEST

FOR EMISSION TESTS

Radiation Worst Case Mode 13

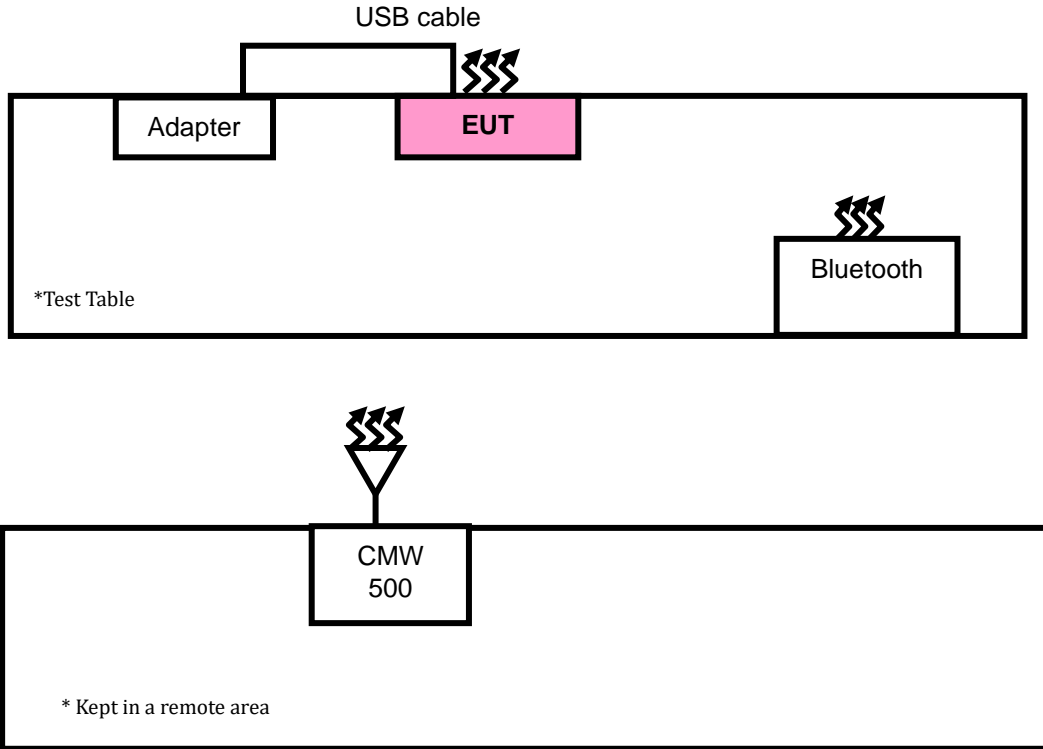



Conduction Worst Case Mode 1

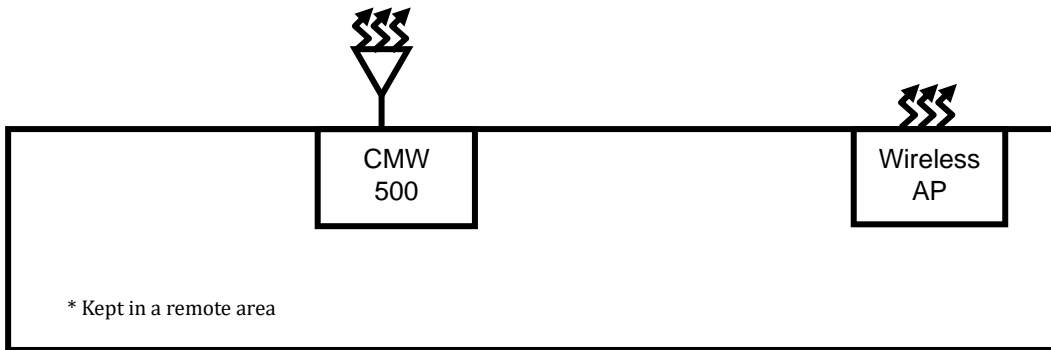
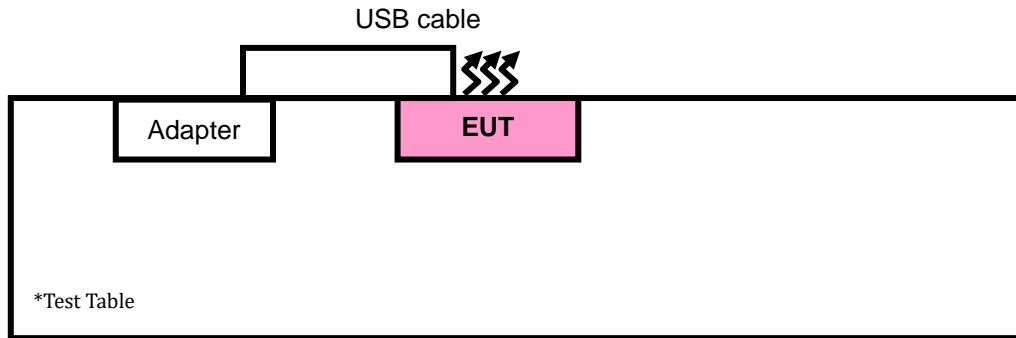



2.6 DESCRIPTION OF SUPPORT UNIT

The EUT has been tested as an independent unit together with other necessary accessories or support units. The following support units or accessories were used to form a representative test configuration during the tests.

FOR ALL TESTS

NO.	PRODUCT	BRAND	MODEL NO.	SERIAL NO.	FCC ID
1	Laptop	Lenovo	Thinkpad L440	R90FTFKP	N/A
2	Bluetooth	FAP00	H6080	12098	N/A
3	Wireless AP	ABOCOM	WR224GR	060500749P	N/A
4	USB Cable	N/A	N/A	N/A	N/A
5	GPS Simulator+Antenna	TOJOIN	GNSS-5000A	E1-010-010119	N/A
6	Universal radio communication tester	Rohde&Schwarz	CMW500	N/A	N/A

NO.	SIGNAL CABLE DESCRIPTION OF THE ABOVE SUPPORT UNITS
1	USB Line: Shielded, Detachable 1m;
2	N/A



3 EMISSION TEST

3.1 CONDUCTED EMISSION MEASUREMENT AT MAINS PORTS

3.1.1 LIMITS OF CONDUCTED EMISSION MEASUREMENT

Frequency (MHz)	Class A (dBuV)		Class B (dBuV)	
	Quasi-peak	Average	Quasi-peak	Average
0.15-0.5	79	66	66-56	56-46
0.5-5	73	60	56	46
5-30	73	60	60	50

Requirements for asymmetric mode conducted emissions

Frequency (MHz)	Class A (dBuV)		Class B (dBuV)	
	Quasi-peak	Average	Quasi-peak	Average
0.15-0.5	97-87	84-74	84-74	74-64
0.5-30	87	74	74	64

- NOTE:** 1. The lower limit shall apply at the transition frequencies.
 2. The limit decreases in line with the logarithm of the frequency in the range of 0.15 to 0.50 MHz.
 3. All emanations from a class A/B digital device or system, including any network of conductors and apparatus connected thereto, shall not exceed the level of field strengths specified above.

3.1.2 TEST INSTRUMENTS

Equipment	Manufacturer	Model No.	Serial No.	Last Cal.	Next Cal.
EMI Test Receiver	Rohde&Schwarz	ESR3	101900	Feb. 14,23	Feb. 13,24
EMI Test Receiver	Rohde&Schwarz	ESR3	101900	Feb. 13,24	Feb. 12,25
EMC32 test software	Rohde&Schwarz	EMC32	NA	NA	NA
LISN network	Rohde&Schwarz	ENV216	101922	Mar. 10,23	Mar. 09,24
LISN network	Rohde&Schwarz	ENV216	101922	Mar. 09,24	Mar. 08,25

- NOTE:** 1. The calibration interval of the above test instruments is 12 months and the calibrations are traceable to CEPREI/CHINA, GRGT/CHINA and NIM/CHINA.
 2. The test was performed in CE Shielded Room.



3.1.3 TEST PROCEDURE

- a. The EUT was placed 0.4 meters from the conducting wall of the shielded room with EUT being connected to the power mains through a line impedance stabilization network (LISN). Other support units were connected to the power mains through another LISN. The two LISNs provide 50 Ohm/ 50uH of coupling impedance for the measuring instrument.
- b. Both lines of the power mains connected to the EUT were checked for maximum conducted interference.
- c. The frequency range from 150 kHz to 30 MHz was searched. Emission levels under Limit - 20dB was not recorded.



3.1.4 DEVIATION FROM TEST STANDARD

No deviation.

3.1.5 TEST SETUP

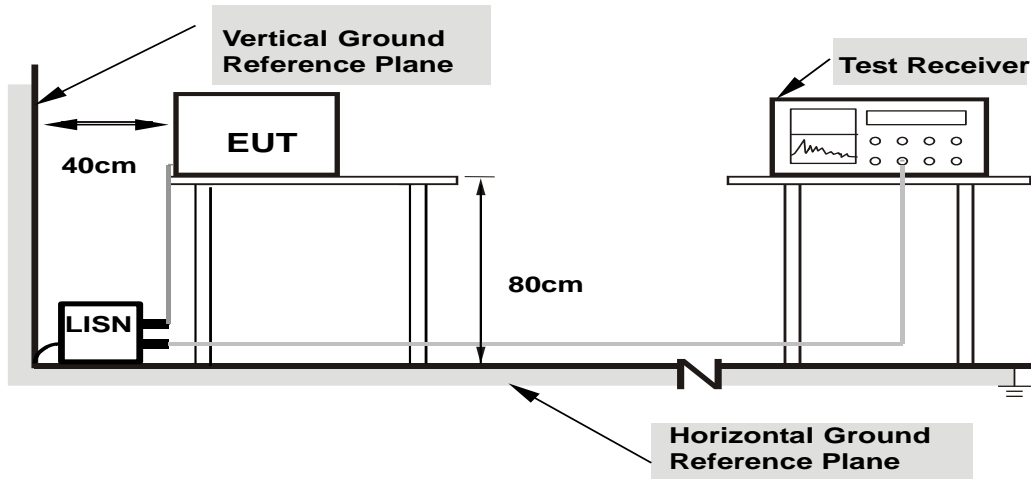

Note: 1.Support units were connected to second LISN.

2.Both of LISNs (AMN) are 80 cm from EUT and at least 80 cm from other units and other metal planes

For the actual test configuration, please refer to the related item – Photographs of the Test Configuration.

3.1.6 EUT OPERATING CONDITIONS

Same as clause 2.3



3.1.7 TEST RESULTS

CONDUCTED WORST-CASE DATA (AC mains power ports):

TEST VOLTAGE	Input 230 Vac, 50 Hz	DETECTOR FUNCTION & RESOLUTION BANDWIDTH	Quasi-Peak(QP)/ Average(AV), 9 KHz
ENVIRONMENTAL CONDITIONS	26deg. C, 51% RH	TESTED BY	Carl xie

Frequency (MHz)	QuasiPeak (dBuV)	CAverage (dBuV)	Limit (dBuV)	Margin (dB)	Line	Filter	Corr. (dB)
0.512000	---	34.86	46.00	11.14	L1	ON	9.8
0.512000	40.18	---	56.00	15.82	L1	ON	9.8
0.940000	---	27.62	46.00	18.38	L1	ON	9.8
0.940000	37.63	---	56.00	18.37	L1	ON	9.8
1.292000	---	24.31	46.00	21.69	L1	ON	9.8
1.292000	36.02	---	56.00	19.98	L1	ON	9.8
2.432000	---	25.01	46.00	20.99	L1	ON	9.8
2.432000	34.04	---	56.00	21.96	L1	ON	9.8
3.700000	---	14.73	46.00	31.27	L1	ON	9.8
3.700000	29.34	---	56.00	26.66	L1	ON	9.8
10.668000	---	21.34	50.00	28.66	L1	ON	10.5
10.668000	31.29	---	60.00	28.71	L1	ON	10.5

- REMARKS:**
1. Q.P. and AV. are abbreviations of quasi-peak and average individually.
 2. "-": The Quasi-peak reading value also meets average limit and measurement with the average detector is unnecessary.
 3. The emission levels of other frequencies were very low against the limit.
 4. Margin value = Limit value - Emission level
 5. Correction factor = Insertion loss + Cable loss
 6. Emission Level = Correction Factor + Reading Value.

Full Spectrum

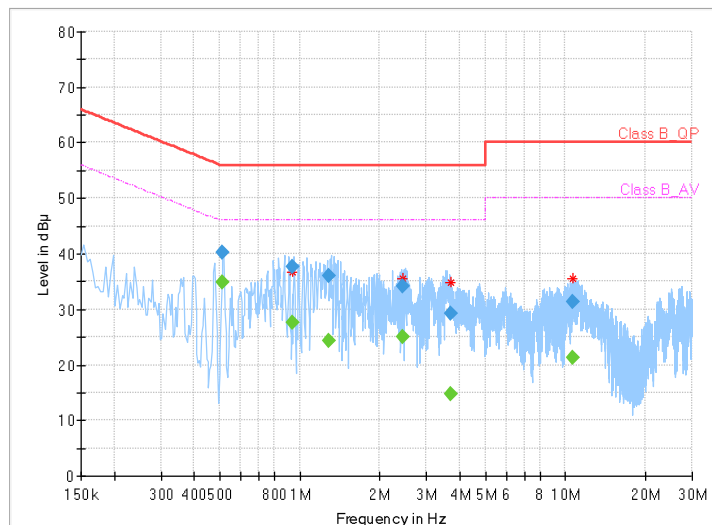



TEST VOLTAGE	Input 230 Vac, 50 Hz	DETECTOR FUNCTION & RESOLUTION BANDWIDTH	Quasi-Peak(QP)/ Average(AV), 9 KHz
ENVIRONMENTAL CONDITIONS	26deg. C, 51% RH	TESTED BY	Carl xie

Frequency (MHz)	QuasiPeak (dBuV)	CAverage (dBuV)	Limit (dBuV)	Margin (dB)	Line	Filter	Corr. (dB)
0.508000	---	36.86	46.00	9.14	N	ON	9.7
0.508000	44.01	---	56.00	11.99	N	ON	9.7
0.860000	---	35.58	46.00	10.42	N	ON	9.7
0.860000	42.88	---	56.00	13.12	N	ON	9.7
0.976000	---	35.75	46.00	10.25	N	ON	9.7
0.976000	43.60	---	56.00	12.40	N	ON	9.7
1.288000	---	35.02	46.00	10.98	N	ON	9.7
1.288000	43.34	---	56.00	12.66	N	ON	9.7
2.420000	---	30.41	46.00	15.59	N	ON	9.8
2.420000	39.72	---	56.00	16.28	N	ON	9.8
3.592000	---	29.20	46.00	16.80	N	ON	9.7
3.592000	39.50	---	56.00	16.50	N	ON	9.7

- REMARKS:**
1. Q.P. and AV. are abbreviations of quasi-peak and average individually.
 2. "-": The Quasi-peak reading value also meets average limit and measurement with the average detector is unnecessary.
 3. The emission levels of other frequencies were very low against the limit.
 4. Margin value = Limit value - Emission level
 5. Correction factor = Insertion loss + Cable loss
 6. Emission Level = Correction Factor + Reading Value.

Full Spectrum

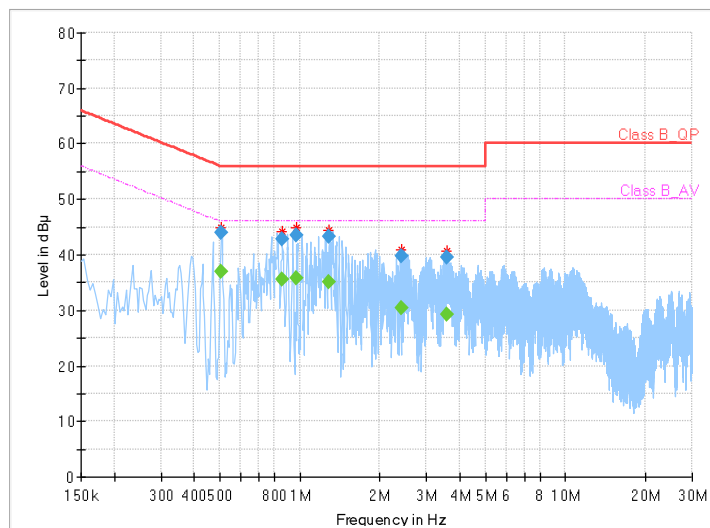



3.2 RADIATED DISTURBANCE MEASUREMENT

3.2.1 LIMITS OF RADIATED EMISSION MEASUREMENT

FOR FREQUENCY BELOW 1000 MHz

Frequency (MHz)	Class A (at 10m)		Class B (at 10m)	
	Quasi-peak (dBuV/m)		Quasi-peak (dBuV/m)	
30-230	40		30	
230-1000	47		37	
Frequency (MHz)	Class A (at 3m)		Class B (at 3m)	
	Quasi-peak (dBuV/m)		Quasi-peak (dBuV/m)	
30-230	50		40	
230-1000	57		47	

FOR FREQUENCY ABOVE 1000 MHz

Frequency (MHz)	Class A (at 3m)		Class B (at 3m)	
	Peak (dBuV/m)	Average (dBuV/m)	Peak (dBuV/m)	Average (dBuV/m)
1000-3000	76	56	70	50
3000-6000	80	60	74	54

- NOTE:**
1. The lower limit shall apply at the transition frequencies.
 2. Emission level (dBuV/m) = 20 log Emission level (uV/m).
 3. All emanations from a class A/B digital device or system, including any network of conductors and apparatus connected thereto, shall not exceed the level of field strengths specified above.



FREQUENCY RANGE OF RADIATED MEASUREMENT

Highest frequency generated or used within the EUT or on which the EUT operates or tunes (MHz)	Upper frequency of measurement range (MHz)
Below 108	1000
108-500	2000
500-1000	5000
Above 1000	Up to 5 times of the highest frequency or 6 GHz, whichever is less

3.2.2 TEST INSTRUMENTS

Frequency range below 1GHz

Equipment	Manufacturer	Model No.	Serial No.	Last Cal.	Next Cal.
3m Semi-anechoic Chamber	ETS-LINDGREN	9m*6m*6m	Euroshieldpn-CT0001143-1216	Nov. 14,23	Nov. 13,26
Bilog Antenna	ETS-LINDGREN	3143B	00161965	Feb. 18,23	Feb. 17,24
Bilog Antenna	ETS-LINDGREN	3143B	00161965	Feb. 17,24	Feb. 16,25
MXE EMI Receiver	KEYSIGHT	N9038A-544	MY54450026	Mar. 28,23	Mar. 27,24
Signal Pre-Amplifier	EMSI	EMC 9135	980249	May. 06,23	May. 05,24
E3 Test Software	E3	V 9.160323	N/A	N/A	N/A

Frequency range above 1GHz

Equipment	Manufacturer	Model No.	Serial No.	Last Cal.	Next Cal.
3m Semi-anechoic Chamber	ETS-LINDGREN	9m*6m*6m	Euroshieldpn-CT0001143-1216	Nov. 14,23	Nov. 13,26
Horn Antenna	ETS-LINDGREN	3117	00168728	Nov. 30,23	Nov. 29,24
MXE EMI Receiver	KEYSIGHT	N9038A-544	MY54450026	Mar. 28,23	Mar. 27,24
Signal Pre-Amplifier	EMSI	EMC 012645B	980257	May.10,23	May.09,24
E3 Test Software	E3	V 9.160323	N/A	N/A	N/A

- NOTE:**
1. The calibration interval of the above test instruments is 12 months or 36 months and the calibrations are traceable to CEPREI/CHINA, GRGT/CHINA and NIM/CHINA.
 2. The test was performed in 3m Chamber.



3.2.3 TEST PROCEDURE

Frequency range 30MHz~1GHz

- a. The EUT was placed on the top of a rotating table 0.8 meters above the ground at a 3 meter semi-anechoic chamber room. The table was rotated 360 degrees to determine the position of the highest radiation.
- b. The EUT was set 3 meters away from the interference-receiving antenna, which was mounted on the top of a variable-height antenna tower.
- c. The height of antenna is varied from 1 meter to 4 meters above the ground to determine the maximum value of the field strength. Both horizontal and vertical polarizations of the antenna are set to make the measurement.
- d. For each suspected emission, the EUT was arranged to its worst case and then the antenna was tuned to heights from 1 meter to 4 meters and the rotatable table was turned from 0 degrees to 360 degrees to find the maximum reading.
- e. The test-receiver system was set to quasi-peak detect function and specified bandwidth with maximum hold mode when the test frequency is below 1GHz.

NOTE:

1. The resolution bandwidth of test receiver/spectrum analyzer is 120kHz for Quasi-peak detection (QP) at frequency below 1GHz.
2. Emission level(dBuV/m)=Raw Value(dBuV) + Correction Factor(dB/m)
3. Correction Factor(dB/m) = Antenna Factor (dB/m) + Cable Factor (dB) (if the raw value not contains the amplifier);
4. Correction Factor (dB/m) = Antenna Factor (dB/m) + Cable Factor (dB) – Amplifier Gain (dB) (if the raw value contains the amplifier).
5. Margin value = Emission level – Limit value.



Frequency range above 1GHz

- a. The EUT was placed on the top of a rotating table 0.8 meters above the ground at a 3 meter Fully-anechoic chamber room. The table was rotated 360 degrees to determine the position of the highest radiation.
- b. The EUT was set 3 meters away from the interference-receiving antenna, which was mounted on the top of a variable-height antenna tower.
- c. The height of antenna can be varied from 1 meter to 4 meters, the height of adjustment depends on the EUT height and the antenna 3dB beamwidth both, to detect the maximum value of the field strength. Both horizontal and vertical polarizations of the antenna are set to make the measurement. The bore sight should be used during the test above 1GHz.
- d. For each suspected emission, the EUT was arranged to its worst case and then the antenna was tuned to heights and the rotatable table was turned from 0 degrees to 360 degrees to find the maximum reading.
- e. The test receiver/spectrum was set to peak and average detect function and specified bandwidth with maximum hold mode when the test frequency is above 1GHz.

NOTE:

1. The resolution bandwidth is 1MHz and video bandwidth of test receiver/spectrum analyzer is 3MHz for Peak detection at frequency above 1GHz. The resolution bandwidth of test receiver/spectrum analyzer is 1 MHz for Average detection (AV) at frequency above 1GHz.
2. For measurement of frequency above 1000 MHz, the EUT was set 3 meters away from the receiver antenna.
3. Emission level(dBuV/m)=Raw Value(dBuV) + Correction Factor(dB/m)
4. Correction Factor(dB/m) = Antenna Factor (dB/m) + Cable Factor (dB) (if the raw value not contains the amplifier);
5. Correction Factor (dB/m) = Antenna Factor (dB/m) + Cable Factor (dB) – Amplifier Gain(dB) (if the raw value contains the amplifier).
6. Margin value = Emission level – Limit value.

3.2.4 DEVIATION FROM TEST STANDARD

No deviation.



3.2.5 TEST SETUP

<Frequency Range below 1GHz>

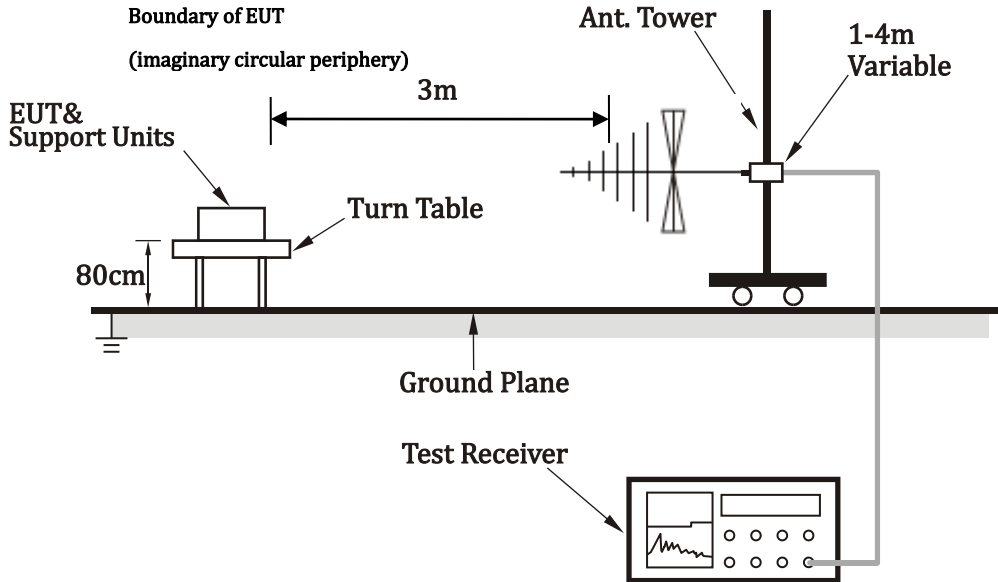

<Frequency Range above 1GHz>

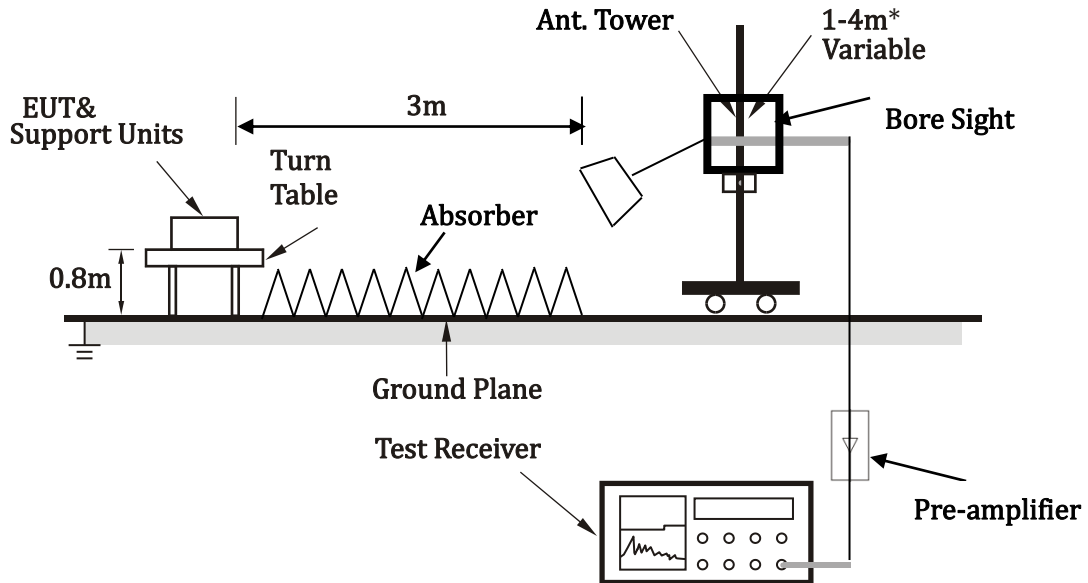

Note: Above 1G is a directional antenna

* depends on the EUT height and the antenna 3dB beam width both, refer to section 7.3 of CISPR 16-2-3.

3.2.6 EUT OPERATING CONDITIONS

Same as clause 2.3



3.2.7 TEST RESULTS

Below 1GHz worst case data:

TEST VOLTAGE	Input 230 Vac, 50 Hz	FREQUENCY RANGE	30-1000 MHz
ENVIRONMENTAL CONDITIONS	23deg. C, 50% RH	DETECTOR FUNCTION & RESOLUTION BANDWIDTH	Quasi-Peak , 120 kHz
TESTED BY	Jace Hu		

ANTENNA POLARITY & TEST DISTANCE: HORIZONTAL AT 3 M

	Freq	Level	Read Level	Limit Line	Over Limit	Factor	Remark	Pol/Phase
	MHz	dBuV/m	dBuV	dBuV/m	dB	dB/m		
1	30.000	23.14	33.98	40.00	-16.86	-10.84	Peak	Horizontal
2	121.180	18.08	40.04	40.00	-21.92	-21.96	Peak	Horizontal
3 PP	214.300	23.21	41.40	40.00	-16.79	-18.19	Peak	Horizontal
4	253.100	25.03	40.84	47.00	-21.97	-15.81	Peak	Horizontal
5	304.510	24.36	39.24	47.00	-22.64	-14.88	Peak	Horizontal
6	454.860	25.30	36.65	47.00	-21.70	-11.35	Peak	Horizontal

- REMARKS:**
1. Emission level(dBuV/m)=Read Value(dBuV) + Correction Factor(dB/m)
 2. Correction Factor(dB/m) = Antenna Factor (dB/m) + Cable Factor (dB) -Amplifier Gain
 3. The other emission levels were very low against the limit.
 4. Margin value = Emission level – Limit value.

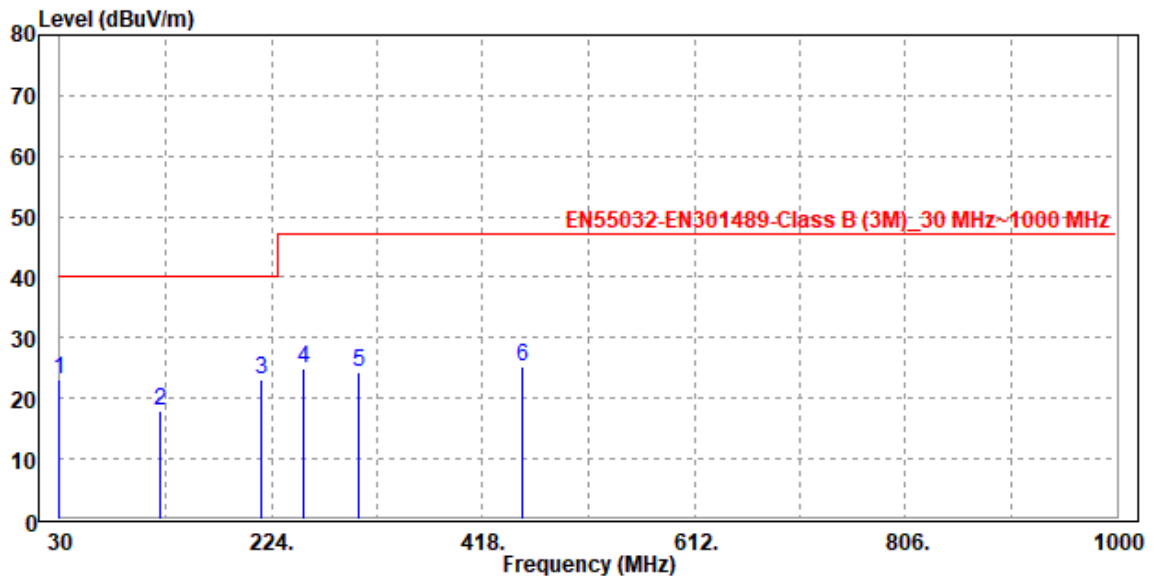



TEST VOLTAGE	Input 230 Vac, 50 Hz	FREQUENCY RANGE	30-1000 MHz
ENVIRONMENTAL CONDITIONS	23deg. C, 50% RH	DETECTOR FUNCTION & RESOLUTION BANDWIDTH	Quasi-Peak , 120 kHz
TESTED BY	Jace Hu		

ANTENNA POLARITY & TEST DISTANCE: VERTICAL AT 3 M

	Freq	Level	Read Level	Limit Line	Over Limit	Factor	Remark	Pol/Phase
	MHz	dBuV/m	dBuV	dBuV/m	dB	dB/m		
1 PP	30.970	32.11	43.10	40.00	-7.89	-10.99	Peak	Vertical
2	62.980	29.73	53.08	40.00	-10.27	-23.35	Peak	Vertical
3	120.210	29.84	48.88	40.00	-10.16	-19.04	Peak	Vertical
4	168.710	20.80	36.81	40.00	-19.20	-16.01	Peak	Vertical
5	284.140	19.70	34.63	47.00	-27.30	-14.93	Peak	Vertical
6	450.010	25.23	35.87	47.00	-21.77	-10.64	Peak	Vertical

- REMARKS:**
1. Emission level(dBuV/m)=Read Value(dBuV) + Correction Factor(dB/m)
 2. Correction Factor(dB/m) = Antenna Factor (dB/m) + Cable Factor (dB) -Amplifier Gain
 3. The other emission levels were very low against the limit.
 4. Margin value = Emission level – Limit value.

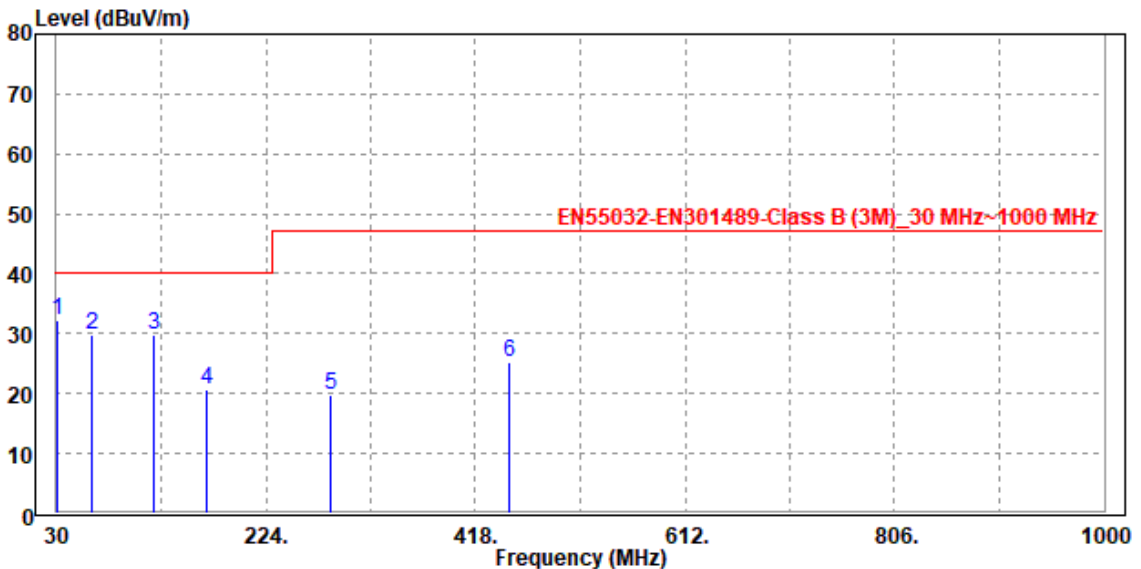



Above 1GHz worst case data:

TEST VOLTAGE	Input 230 Vac, 50 Hz	FREQUENCY RANGE	1-6 GHz
ENVIRONMENTAL CONDITIONS	23deg. C, 50% RH	DETECTOR FUNCTION & RESOLUTION BANDWIDTH	Peak/Average, 1 MHz
TESTED BY	Jace Hu		

ANTENNA POLARITY & TEST DISTANCE: HORIZONTAL AT 3 M										
FREQ. (MHz)	EMISSION LEVEL (dBuV/m)	READ LEVEL (dBuV)	LIMIT (dBuV/m)	MARGIN (dB)	ANTENNA FACTOR (dB /m)	CABLE LOSS (dB)	PREAMP FACTOR (dB)	ANTENNA HEIGHT (cm)	TABLE ANGLE (Degree)	REMARK
1320	36.81	50.19	70	-33.19	27.92	5.88	47.18	100	160	Peak
1320	26.27	39.65	50	-23.73	27.92	5.88	47.18	100	160	Average
1980	40.72	49.04	70	-29.28	30.88	7.13	46.33	100	59	Peak
1980	31.96	40.28	50	-18.04	30.88	7.13	46.33	100	59	Average
2695	43.72	49.5	70	-26.28	32.19	8.17	46.14	100	96	Peak
2695	35.87	41.65	50	-14.13	32.19	8.17	46.14	100	96	Average
3610	43.58	48.73	74	-30.42	32.93	9.5	47.58	100	50	Peak
3610	34.37	39.52	54	-19.63	32.93	9.5	47.58	100	50	Average
4055	44.1	49.2	74	-29.9	33.51	9.82	48.43	100	110	Peak
4055	33.87	38.97	54	-20.13	33.51	9.82	48.43	100	110	Average
5205	48.44	49.47	74	-25.56	34.28	11.23	46.54	100	90	Peak
5205	40.43	41.46	54	-13.57	34.28	11.23	46.54	100	90	Average

ANTENNA POLARITY & TEST DISTANCE: VERTICAL AT 3 M										
FREQ. (MHz)	EMISSION LEVEL (dBuV/m)	READ LEVEL (dBuV)	LIMIT (dBuV/m)	MARGIN (dB)	ANTENNA FACTOR (dB /m)	CABLE LOSS (dB)	PREAMP FACTOR (dB)	ANTENNA HEIGHT (cm)	TABLE ANGLE (Degree)	REMARK
1385	36.61	49.69	70	-33.39	27.98	6.04	47.1	100	85	Peak
1385	28	41.08	50	-22	27.98	6.04	47.1	100	85	Average
1990	40.65	48.67	70	-29.35	31.14	7.15	46.31	100	42	Peak
1990	32.58	40.6	50	-17.42	31.14	7.15	46.31	100	42	Average
2415	44.41	50.89	70	-25.59	31.95	7.77	46.2	100	155	Peak
2415	33.19	39.67	50	-16.81	31.95	7.77	46.2	100	155	Average
3210	43.26	48.41	74	-30.74	32.64	8.8	46.59	100	60	Peak
3210	34.8	39.95	54	-19.2	32.64	8.8	46.59	100	60	Average
3990	43.35	48.74	74	-30.65	33.39	9.74	48.52	100	90	Peak
3990	33.48	38.87	54	-20.52	33.39	9.74	48.52	100	90	Average
4915	46.93	48.41	74	-27.07	34.28	10.9	46.66	100	36	Peak
4915	37.72	39.2	54	-16.28	34.28	10.9	46.66	100	36	Average

- REMARKS:**
1. Emission level(dBuV/m)=Raw Value(dBuV) + Correction Factor(dB/m)
 2. Correction Factor(dB/m) = Antenna Factor (dB/m) + Cable Factor (dB)- Amplifier Gain
 3. The other emission levels were very low against the limit.
 4. Margin value = Emission level – Limit value.



3.3 HARMONICS CURRENT MEASUREMENT

3.3.1 LIMITS OF HARMONICS CURRENT MEASUREMENT

TEST STANDARD: EN IEC 61000-3-2

Limits for Class A equipment	
Harmonics Order n	Max. permissible harmonics current A
Odd harmonics	
3	2.30
5	1.14
7	0.77
9	0.40
11	0.33
13	0.21
15<=n<=39	0.15x15/n
Even harmonics	
2	1.08
4	0.43
6	0.30
8<=n<=40	0.23x8/n

Limits for Class D equipment		
Harmonics Order n	Max. permissible harmonics current per watt mA/W	Max. permissible harmonics current A
Odd Harmonics only		
3	3.4	2.30
5	1.9	1.14
7	1.0	0.77
9	0.5	0.40
11	0.35	0.33
13	0.30	0.21
15<=n<=39	3.85/n	0.15x15/n

- NOTE:** 1. Class A and Class D are classified according to item section 5 of EN IEC 61000-3-2.
 2. According to section 7 of EN IEC 61000-3-2, the above limits for all equipment except for lighting equipment having an active input power > 75 W and no limits apply for equipment with an active input power up to and including 75 W.



3.3.2 TEST PROCEDURE

- a. The EUT was placed on the top of a wooden table 0.8 meters above the ground and operated to produce the maximum harmonic components under normal operating conditions for each successive harmonic component in turn.

The classification of EUT is according to section 5 of EN IEC 61000-3-2.

The EUT is classified as follows:

Class A	Class B	Class C	Class D
Equipment not specified as belonging to Class B, C or D shall be considered as Class A equipment. Some examples of Class A equipment are: – balanced three-phase equipment; – household appliances, excluding those specified as belonging to Class B, C or D; – vacuum cleaners; – high pressure cleaners; – tools, excluding portable tools; – independent phase control dimmers; – audio equipment; – professional luminaires for stage lighting and studios	Portable tools; Arc welding equipment which is not professional equipment.	Lighting equipment.	Equipment having a specified power less than or equal to 600 W of the following types: Personal computers and personal computer monitors; Television receivers; Refrigerators and freezers having one or more variable-speed drives to control compressor motor(s).

- b. The correspondent test program of test instrument to measure the current harmonics emanated from EUT is chosen. The measure time shall be not less than the time necessary for the EUT to be exercised.



3.3.3 DEVIATION FROM TEST STANDARD

No deviation.

3.3.4 TEST SETUP

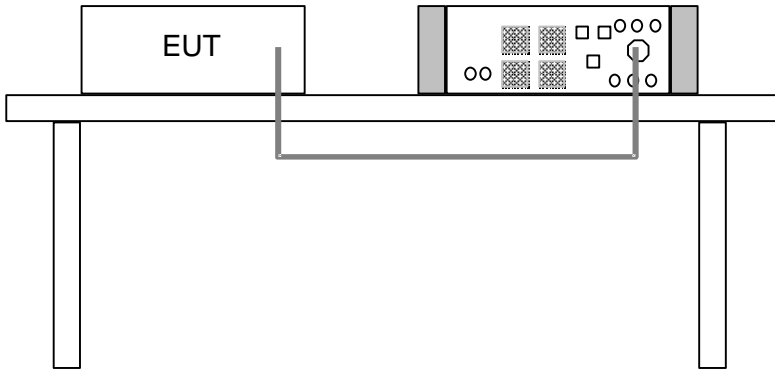

3.3.5 TEST RESULTS

As specified on section 7 and above figure of EN IEC 61000-3-2, the limit is not specified for equipment with a rated power of 75W or less.
The EUT meets the above condition, so it conforms to EN IEC 61000-3-2.



3.4 VOLTAGE FLUCTUATION AND FLICKS MEASUREMENT

3.4.1 TEST INSTRUMENTS

Equipment	Manufacturer	Model No.	Serial No.	Last Cal.	Next Cal.
HARMONICS 1000	EMC-PARTNER	HAR1000-1P	103488-0265	Feb. 24,23	Feb. 23,24
software	EMC-PARTNER	83L72H866	0265	N/A	N/A

3.4.2 LIMITS OF VOLTAGE FLUCTUATION AND FLICKS MEASUREMENT

TEST STANDARD: EN 61000-3-3

Test Item	Limit	Note
P_{st}	1.0	P_{st} means short-term flicker indicator.
P_{lt}	0.65	P_{lt} means long-term flicker indicator.
T_{dt} (ms)	500	T_{dt} means maximum time that dt exceeds 3.3 %.
d_{max} (%)	4%	d_{max} means maximum relative voltage change.
dc (%)	3.3%	dc means relative steady-state voltage change

3.4.3 TEST PROCEDURE

- a. The EUT was placed on the top of a wooden table 0.8 meters above the ground and operated to produce the most unfavorable sequence of voltage changes under normal operating conditions.
- b. During the flick measurement, the measure time shall include that part of whole operation cycle in which the EUT produce the most unfavorable sequence of voltage changes. The observation period for short-term flicker indicator is 10 minutes and the observation period for long-term flicker indicator is 2 hours.



3.4.4 DEVIATION FROM TEST STANDARD

No deviation.

3.4.5 TEST SETUP

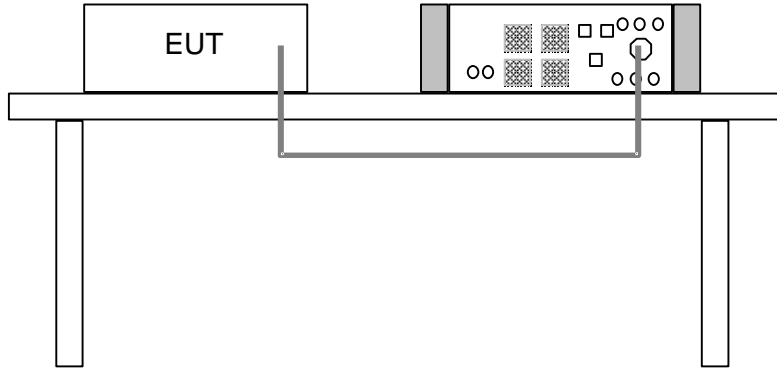

3.4.6 TEST RESULTS

TEST VOLTAGE	Input 230 Vac, 50 Hz		
ENVIRONMENTAL CONDITIONS	25deg. C, 52% RH	TESTED BY	Carl Xie

T-max (mS):	0	Test limit (mS):	500.0	pass
Highest dc (%):	0.01	Test limit (%):	3.30	pass
Highest dmax (%):	0.00	Test limit (%):	4.00	pass
Highest Pst (10 min. period):	0.07	Test limit:	1.00	pass
Highest Plt (2 hr. period):	0.07	Test limit:	0.650	pass



4 IMMUNITY TEST

4.1 GENERAL DESCRIPTION

EN 301 489-1 V2.2.3 (2019-11) / EN 301 489-3 V2.3.2 (2023-01)/ Draft EN 301 489-17 V3.2.6 (2023-06)/ EN 301 489-19 V2.2.1 (2022-09)/ EN 301 489-52 V1.2.1 (2021-11),Immunity requirements			
Clause	Reference standard	Test specification	Performance Criterion
9.3	EN 61000-4-2 ESD	Enclosure port: ±8 kV Air discharge, ±4 kV Contact discharge	TRANSIENT PHENOMENA
9.2	EN IEC 61000-4-3 RS	Enclosure port: 80-6000 MHz, 3 V/m, 80 % AM (1 kHz)	CONTINUOUS PHENOMENA
9.4	EN 61000-4-4 EFT	Signal ports, telecommunication ports and control ports: ±0.5 kV, 5/50 T _r /T _h ns, 5kHz Input DC power ports: ±0.5 kV, 5/50 T _r /T _h ns, 5 kHz Input AC Power ports: ±1 kV, 5/50 T _r /T _h ns, 5 kHz	TRANSIENT PHENOMENA
9.8	EN 61000-4-5 Surge	Wired network ports(directly connected to outdoor cables): Symmetrically operated : ±1 kV, 10/700 Tr/Th μs Non-symmetrically operated : line to line: ±0.5 kV, 1.2/50 Tr/Th μs line to ground: ±1 kV, 1.2/50 Tr/Th μs Wired network ports(indoor cables, longer than 30 m): ±0.5 kV, 1.2/50 Tr/Th μs	TRANSIENT PHENOMENA
		Input AC Power ports: Telecom centres: line to line: ±0.5 kV, 1.2/50 Tr/Th μs line to ground: ±1 kV, 1.2/50 Tr/Th μs Others: line to line: ±1 kV, 1.2/50 Tr/Th μs line to ground: ±2 kV, 1.2/50 Tr/Th μs	TRANSIENT PHENOMENA
9.5	EN 61000-4-6 CS	Signal ports, telecommunication ports, control ports and DC power ports (if cables length > 3 m): 0.15-80 MHz, 3 V, 80 % AM (1 kHz) AC Power ports: 0.15-80 MHz, 3 V, 80 % AM (1 kHz)	CONTINUOUS PHENOMENA



9.7	EN 61000-4-11 Dips & Interruptions	AC Power ports: Voltage Dips: 0 % residual, 0.5 cycle 0 % residual, 1 cycle 70 % residual, 25 cycles (at 50 Hz) Voltage Interruptions: 0 % residual, 250 cycles (at 50 Hz) EUT with battery back-up EUT without battery back-up	TRANSIENT PHENOMENA
-----	--	---	------------------------



4.2 PERFORMANCE CRITERIA

General Performance Criteria:

Performance criteria for continuous phenomena

During the test, the equipment shall:

- continue to operate as intended;
- not unintentionally transmit;
- not unintentionally change its operating state;
- not unintentionally change critical stored data.

Performance criteria for transient phenomena

For all ports and transient phenomena with the exception described below, the following applies:

- The application of the transient phenomena shall not result in a change of the mode of operation (e.g. unintended transmission) or the loss of critical stored data.
- After application of the transient phenomena, the equipment shall operate as intended.

For surges applied to symmetrically operated wired network ports intended to be connected directly to outdoor lines the following criteria applies:

- For products with only one symmetrical port intended for connection to outdoor lines, loss of function is allowed, provided the function is self-recoverable, or can be otherwise restored. Information stored in non-volatile memory, or protected by a battery backup, shall not be lost.
- For products with more than one symmetrical port intended for connection to outdoor lines, loss of function on the port under test is allowed, provided the function is self-recoverable. Information stored in non-volatile memory, or protected by a battery backup, shall not be lost.

Final Draft EN 301 489-3, SRD

TYPE of Device

Device Type	Risk assessment of communication link performance
1	Highly reliable SRD communication media; e.g. serving human life inherent systems (may result in a physical risk to a person)
2	Medium reliable SRD communication media; e.g. causing inconvenience to persons, which cannot simply be overcome by other means
3	Standard reliable SRD communication media; e.g. inconvenience to persons, which can simply be overcome by other means (e.g. manual)

The performance criteria are:

Performance criterion A applies for immunity tests with phenomena of a continuous nature;

Performance criterion B applies for immunity tests with phenomena of a transient nature.

Table 2: Performance Requirements

Criterion	During test	After test
A	Operate as intended No loss of function No unintentional responses	Operate as intended No loss of function No degradation of performance No loss of stored data or user programmable functions
B	May show loss of function No unintentional responses	Operate as intended Lost function(s) shall be self-recoverable No degradation of performance No loss of stored data or user programmable functions



EN 301 489-17, Broadband Data Transmission Systems

Special conditions for EN 301489-17		
Criteria	During test	After test (i.e. as a result of the application of the test)
A	Shall operate as intended. (See Note1). Shall be no loss of function. Shall be no unintentional transmissions.	Shall operate as intended. Shall be no degradation of performance. Shall be no loss of function. Shall be no loss of critical stored data
B	May be loss of function.	Functions shall be self-recoverable. Shall operate as intended after recovering. Shall be no loss of critical stored data.
C	May be loss of function.	Functions shall be recoverable by the operator. Shall operate as intended after recovering. Shall be no loss of critical stored data

Note:

- Minimum performance level:
For equipment that supports a PER or FER, the minimum performance level shall be a PER or FER less than or equal to 10 %. For equipment that does not support a PER or a FER, the minimum performance level shall be no loss of the wireless transmission function needed for the intended use of the equipment.
- Performance criteria for Continuous phenomena:
The performance criteria A shall apply. Where the EUT is a transmitter in standby mode, unintentional transmission shall not occur during the test. Where the EUT is a transceiver in receive mode, unintentional transmission shall not occur during the test.
- Performance criteria for Transient phenomena:
The performance criteria B shall apply, except for voltage dips greater than or equal to 100 ms and voltage interruptions of 5 000 ms duration, for which performance criteria C shall apply. Where the EUT is a transmitter in standby mode, unintentional transmission shall not occur as a result of the application of the test. Where the EUT is a transceiver in receive mode, unintentional transmission shall not occur as a result of the application of the test.

Note:

- The WLAN Linking mode is activated and monitoring communication status via notebook by ping command during and after tests.



EN 301 489-19, GPS and GLONASS

If the EUT is of a non-specialized nature or the EUT is combined with an ancillary equipment, the test modulation, test arrangements, etc. as required in clause 4 shall apply.

The EUT, for all immunity tests according to the present document, except the spot frequency test of the immunity test with radiated RF electromagnetic fields (see ETSI EN 301 489-1 [1], clause 9.2), shall be assessed for:

- the storage of messages in the memory of the EUT at the start of the test;
- unintentional responses of the EUT during the test;
- the maintenance of the EUT memory assessed at the conclusion of the test;
- the ability to receive and store messages at the conclusion of the test.

For the spot frequency test of the immunity test with radiated RF electromagnetic fields (see ETSI EN 301 489-1 [1], clause 9.2) the EUT shall be assessed by monitoring the accuracy of the call received alert signal.



The phenomena allowed during and after test are stated in the following table.

Special conditions for EN301489-52	
Criteria	During / After Test
Continuous phenomena applied to Transmitters (CT)	<p>A communication Link shall be established at the start of the test, and maintained during the test, see clauses 4.2.3 and 4.2.4.</p> <p>During the test, the upLink speech output level shall be at least 35 dB less than the previously recorded reference levels, when measured through an audio band pass filter of width 200 Hz, centred on 1 kHz.</p> <p>Note: When there is a high level background noise present the filter bandwidth can be reduced down to a minimum of 40 Hz.</p> <p>At the conclusion of the test, the EUT shall operate as intended with no loss of user control functions or stored data, and the communication Link shall have been maintained. In addition to confirming the above performance during a call, the test shall also be performed in idle mode, and the transmitter shall not unintentionally operate.</p>
Continuous phenomena applied to Receivers (CR)	<p>A communications Link shall be established at the start of the test, clauses 4.2 to 4.2.6.</p> <p>During the test, the RXQUAL of the downLink shall not exceed the value of three, measured during each individual exposure in the test sequence.</p> <p>During the test, the downLink speech output level shall be at least 35 dB less than the previously recorded reference levels, when measured through an audio band pass filter of width 200 Hz, centred on 1 kHz (audio breakthrough check).</p> <p>Note: When there is a high level background noise present the filter bandwidth can be reduced down to a minimum of 40 Hz.</p> <p>At the conclusion of the test, the EUT shall operate, as intended with no loss of user control functions or stored data, and the communication Link shall have been maintained.</p>
Transient phenomena	<p>A communications Link shall be established at the start of the test, see clauses 4.2 to 4.2.4.</p> <p>At the conclusion of each exposure of the transient phenomena, the EUT shall operate without loss of the communication link.</p> <p>At the conclusion of the total test comprising the series of individual exposures, the EUT shall operate as intended without loss of user control functions or critical stored data.</p> <p>In addition where the EUT supports idle mode it should be verified that the transmitter shall not unintentionally operate when transient phenomena are applied.</p>
Ancillary equipment tested on a stand alone bases	<p>The provision of EN 301 489-1, clause 5 shall apply.</p>



EN 301 489-52, UTRA and E-UTRA, Mobile and Portable UE

The equipment shall meet the performance criteria specified in this clause.

The maintenance of a communications Link shall be assessed by using an indicator, which may be part of the test system or the equipment under test.

If an equipment is of a specialized nature, that the performance criteria described in the following clauses are not appropriate, then the manufacturer shall declare, for inclusion in the test report, his own specification for an acceptable level of performance or degradation of performance during and/or after testing, as required by the present document.

The performance criteria specified by the manufacturer shall give the same degree of immunity protection as called for in the following clauses.

In addition, the test shall also be performed in idle mode to ensure the transmitter does not unintentionally operate.

The requirements apply to all types of UTRA and E-UTRA (FDD or TDD) for the UE.

Special conditions for EN301489-52	
Criteria	During / After Test
CONTINUOUS PHENOMENA	<p>With a link established, during the test, the uplink speech output level shall be at least 35 dB less than the previously recorded reference levels, when measured through an audio band pass filter of width 200 Hz, centred on 1 kHz (audio breakthrough check).</p> <p>Note: When there is a high-level background noise present, the filter bandwidth may be reduced down to a minimum of 40 Hz.</p> <p>In idle mode, the transmitter shall not operate unintentionally.</p> <p>At the conclusion of the test, the EUT shall operate as intended with no loss of user control functions or critical stored data, and the communication link shall have been maintained.</p> <p>In addition to confirming the above performance in traffic mode, the test shall be performed in idle mode, and the transmitter shall not unintentionally operate.</p> <p>UTRA</p> <p>In the data transfer mode, the performance criteria can be one of the following:</p> <ul style="list-style-type: none"> • if the BER (as referred in TS 134 109) is used, it shall not exceed 0,001 during the test sequence; • if the BLER (as referred in TS 134 109) is used, it shall not exceed 0,01 during the test sequence. <p>The BLER calculation shall be based on evaluating the CRC on each transport block.</p> <p>E-UTRA</p> <p>In data transfer mode, the performance criteria shall be that the throughput shall be $\geq 95\%$ of the maximum throughput of the reference measurement channel as specified in annex C in TS 136 101 with parameters specified in tables 7.3.1-1 and 7.3.1-2 in TS 136 101 during the test sequence.</p>
TRANSIENT PHENOMENA	<p>A communications Link shall be established at the start of the test.</p> <p>At the conclusion of each exposure the EUT shall operate with no user noticeable loss of the communication Link.</p> <p>At the conclusion of the total test comprising the series of individual exposures, the EUT shall operate as intended with no loss of user control functions or stored data, as declared by the manufacturer, and the communication Link shall have been maintained.</p> <p>In addition where the EUT supports idle mode it should be verified that the transmitter shall not unintentionally operate when transient phenomena are applied.</p>



4.3 ELECTROSTATIC DISCHARGE IMMUNITY TEST (ESD)

4.3.1 TEST SPECIFICATION

Basic Standard:	EN 61000-4-2
Discharge Impedance:	330 ohm /150 pF
Discharge Voltage:	Air Discharge: 2, 4, 8 kV (Direct) Contact Discharge: 2, 4 kV Indirect Discharge: 2, 4kV
Polarity:	Positive & Negative
Number of Discharge:	Minimum 20 times at each test point
Discharge Mode:	Single Discharge
Discharge Period:	1 second minimum

4.3.2 TEST INSTRUMENT

Equipment	Manufacturer	Model No.	Serial No.	Last Cal.	Next Cal.
ESD GUN	TESEQ	NSG 438	1399	Feb. 19,23	Feb. 18,24
ESD GUN-POWER	TESEQ	NSG 438-ACC	NA	NA	NA

- NOTE:** 1. The test was performed in EMS Room.
2. The calibration interval of the above test instruments is 12 months and the calibrations are traceable to CEPREI/CHINA, GRGT/CHINA and NIM/CHINA.



4.3.3 TEST PROCEDURE

- a. Electrostatic discharges were applied only to those points and surfaces of the EUT that are accessible to users during normal operation.
- b. The test was performed with at least ten single discharges on the pre-selected points in the most sensitive polarity.
- c. The time interval between two successive single discharges was at least 1 second.
- d. The ESD generator was held perpendicularly to the surface to which the discharge was applied and the return cable was at least 0.2 meters from the EUT.
- e. Contact discharges were applied to the non-insulating coating, with the pointed tip of the generator penetrating the coating and contacting the conducting substrate.
- f. Air discharges were applied with the round discharge tip of the discharge electrode approaching the EUT as fast as possible (without causing mechanical damage) to touch the EUT. After each discharge, the ESD generator was removed from the EUT and re-triggered for a new single discharge. The test was repeated until all discharges were complete.
- g. At least ten single discharges (in the most sensitive polarity) were applied to the **Horizontal Coupling Plane** at points on each side of the EUT. The ESD generator was positioned horizontally at a distance of 0.1 meters from the EUT with the discharge electrode touching the **HCP**.
- h. At least ten single discharges (in the most sensitive polarity) were applied to the center of one vertical edge of the **Vertical Coupling Plane** in sufficiently different positions that the four faces of the EUT were completely illuminated. The **VCP** (dimensions 0.5m x 0.5m) was placed vertically to and 0.1 meters from the EUT.

4.3.4 DEVIATION FROM TEST STANDARD

No deviation.

4.3.5 TEST SETUP

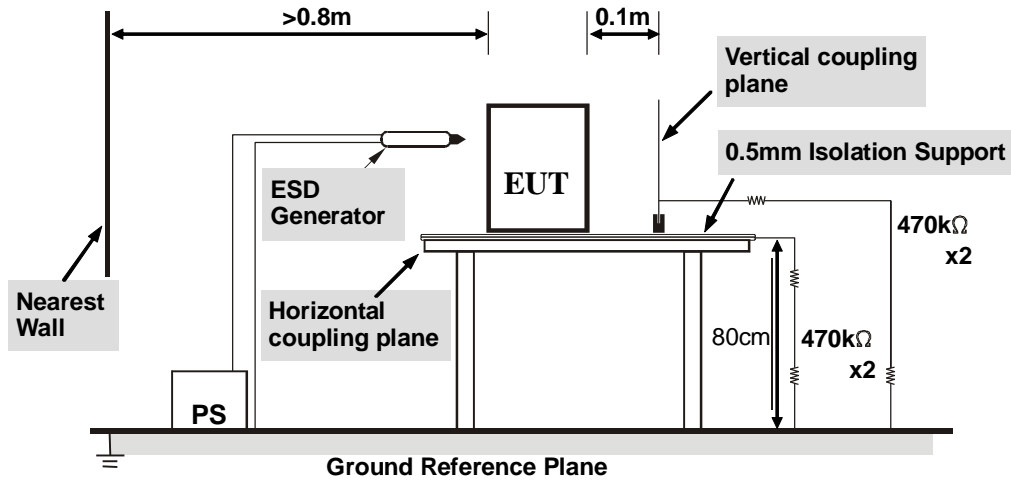

NOTE:

TABLE-TOP EQUIPMENT

The configuration consisted of a wooden table 0.8 meters high standing on the **Ground Reference Plane**. The **GRP** consisted of a sheet of aluminum or copper at least 0.25mm thick, and 2.5 meters square connected to the protective grounding system. A **Horizontal Coupling Plane** (1.6m x 0.8m) was placed on the table and attached to the **GRP** by means of a cable with 940k total impedance. The equipment under test, was installed in a representative system as described in section 7 of EN 61000-4-2, and its cables were placed on the **HCP** and isolated by an insulating support of 0.5mm thickness. A distance of 0.8 meter minimum was provided between the EUT and the walls of the laboratory and any other metallic structure.

FLOOR-STANDING EQUIPMENT

The equipment under test was installed in a representative system as described in section 7 of EN 61000-4-2, and its cables were isolated from the Ground Reference Plane by an insulating support of 0.1-meter thickness. The GRP consisted of a sheet of aluminum or copper that is at least 0.25mm thick, and 2.5 meters square connected to the protective grounding system and extended at least 0.5 meters from the EUT on all sides.



4.3.6 TEST RESULTS

TEST VOLTAGE	Input 230 Vac, 50 Hz	ENVIRONMENTAL CONDITIONS	23deg. C, 51% RH, 101kpa
TEST MODE	See section 2.2	TESTED BY	Carl xie

Discharge Level	Polarity	Test Points	Contact Discharge	Air Discharge	Performance Criterion	Test Result
2,4,8	+/-	N/A	N/A	N/A	TRANSIENT PHENOMENA	Complied
2,4	+/-	N/A	N/A	N/A	TRANSIENT PHENOMENA	Complied
2,4	+/-	HCP	PASS	N/A	TRANSIENT PHENOMENA	Complied
2,4	+/-	VCP	PASS	N/A	TRANSIENT PHENOMENA	Complied

NOTE: 1. The EUT function was correct during the test.



4.4 RADIATED, RADIO-FREQUENCY, ELECTROMAGNETIC FIELD IMMUNITY TEST (RS)

4.4.1 TEST SPECIFICATION

Basic Standard:	EN IEC 61000-4-3
Frequency Range:	80 MHz ~ 6000 MHz
Field Strength:	3 V/m
Modulation:	1 kHz Sine Wave, 80%, AM Modulation
Frequency Step:	1 % of preceding frequency value
Polarity of Antenna:	Horizontal and Vertical
Antenna Height:	1.5 m
Dwell Time:	3 seconds

4.4.2 TEST INSTRUMENT

Equipment	Manufacturer	Model No.	Serial No.	Last Cal.	Next Cal.
Base station R&S CMW500	Rohde&Schwarz	CMW500	153084	Aug. 12,23	Aug. 11, 24
Audio Analyzer	Rohde&Schwarz	UPV	104035	Feb. 14,23	Feb. 13,24
Audio Analyzer	Rohde&Schwarz	UPV	104035	Feb. 13,24	Feb. 12,25
RS Test System TS9982	Rohde&Schwarz	SMB100A + SMB-B106	109279	Feb. 14,23	Feb. 13,24
RS Test System TS9982	Rohde&Schwarz	SMB100A + SMB-B106	109279	Feb. 13,24	Feb. 12,25
EMC32 test software	Rohde&Schwarz	EMC32	NA	NA	NA
POWER AMPLIFIER_RS	Rohde&Schwarz	BBA100-B250	101805	May. 12,23	May. 11,24
Power amplifier 250W	Rohde&Schwarz	BBA1150-D11E 100	101552	Feb. 17, 23	Feb. 16, 24
Power amplifier 250W	Rohde&Schwarz	BBA1150-D11E 100	101552	Feb. 16, 24	Feb. 15, 25
RS Antenna_LF	Rohde&Schwarz	R&S® HL046E	HL064E	NA	NA
RS Antenna_HF	Rohde&Schwarz	STLP 9149	9149-329	NA	NA
3m Fully-anechoic Chamber	ETS-LINDGREN	10m*10m*5m	Euroshieldpn-CT0001143-1217	Nov. 13,23	Nov. 12,26
Ear Simulator	Rohde&Schwarz	4182	2981654	NA	NA
Mouth Simulator	Rohde&Schwarz	4227	2837781	Feb. 25,23	Feb. 24, 24
conditioning Amplifier	Rohde&Schwarz	Type 5935	2997236	Aug. 02,23	Aug. 01, 24
power sensor	Rohde&Schwarz	NRP-Z91	102958	Aug. 11,23	Aug. 10, 24
power sensor	Rohde&Schwarz	NRP-Z91	102959	Feb. 15,23	Feb. 14, 24
power sensor	Rohde&Schwarz	NRP-Z91	102959	Feb. 14, 24	Feb. 13, 25

- NOTE:** 1. The test was performed in RS Room.
 2. The calibration interval of the above test instruments is 12 months and 36 months the calibrations are traceable to CEPREI/CHINA, GRGT/CHINA and NIM/CHINA.



4.4.3 TEST PROCEDURE

The test procedure was in accordance with EN IEC 61000-4-3.

- The testing was performed in a fully-anechoic chamber.
- The frequency range is swept from 80 MHz to 6000 MHz with the signal 80% amplitude modulated with a 1 kHz sine wave.
- The dwell time at each frequency shall not be less than the time necessary for the EUT to be exercised and to respond, but shall in no case be less than 0.5s.
- The field strength level was 3 V/m.
- The test was performed with the EUT exposed to both vertically and horizontally polarized fields on each of the four sides.

4.4.4 DEVIATION FROM TEST STANDARD

No deviation.

4.4.5 TEST SETUP

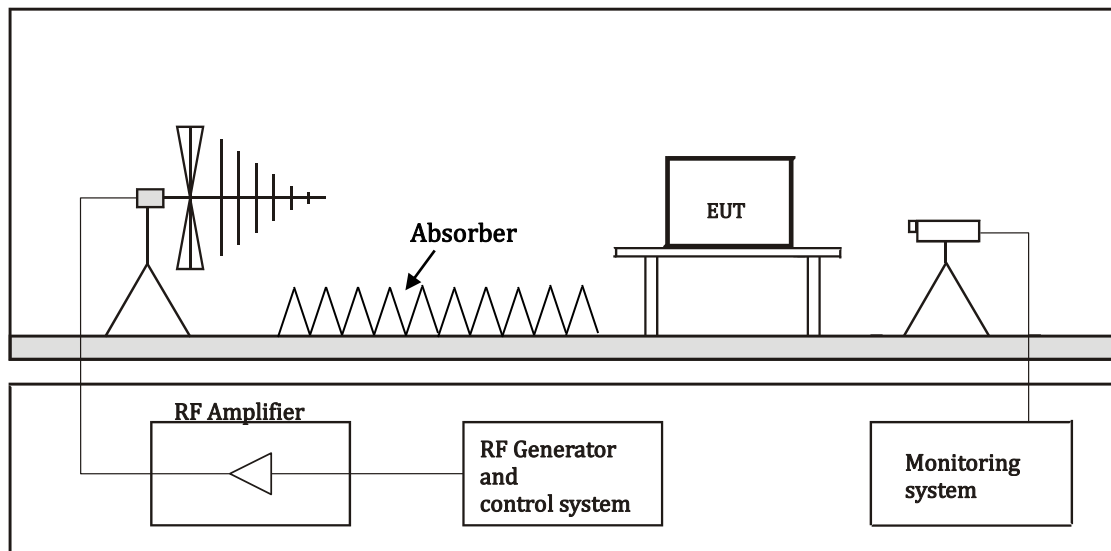

For the actual test configuration, please refer to the related item – Photographs of the Test Configuration.

NOTE:

TABLETOP EQUIPMENT

The EUT installed in a representative system as described in section 7 of EN IEC 61000-4-3 was placed on a non-conductive table 0.8 meters in height. The system under test was connected to the power and signal wire according to relevant installation instructions.



4.4.6 TEST RESULTS

TEST VOLTAGE	Input 230 Vac, 50 Hz	ENVIRONMENTAL CONDITIONS	23deg. C, 52% RH
TEST MODE	1 ~ 2	TESTED BY	David Yuan

Field Strength (V/m)	Test Frequency Note#1 (MHz)	Polarization of antenna (Horizontal / Vertical)	Azimuth (°)	Test Distance (m)	Performance Criterion	Test Result
3	80 - 6000	H&V	0/90/180/270	3	CONTINUOUS PHENOMENON A	Complied

- * The exclusion band for transmitters is 250 % of the channel width either side of the nominal operating frequency of the transmitter.
- * The exclusion band for receivers shall be calculated by using the following formulae:
 For the lower edge for the exclusion band: $EXband(lower) = Band_{RX}(lower) - ChW_{RX}$
 For the upper edge of the exclusion band: $EXband(upper) = Band_{RX}(upper) + ChW_{RX}$
- * GSM and DCS Channel Width 200kHz
- * UTRA Channel Width 5MHz

NOTE:

1. For normal operating function: There was no change compared with the initial operation during and after the test.



TEST VOLTAGE	Input 230 Vac, 50 Hz	ENVIRONMENTAL CONDITIONS	23deg. C, 52% RH
TEST MODE	3 ~ 4	TESTED BY	David Yuan

Field Strength (V/m)	Test Frequency Note#1 (MHz)	Polarization of antenna (Horizontal / Vertical)	Azimuth (°)	Test Distance (m)	Performance Criterion	Test Result
3	80 - 6000	H&V	0/90/180/270	3	CONTINUOUS PHENOMENA	Complied

- * The exclusion band for transmitters is 250 % of the channel width either side of the nominal operating frequency of the transmitter.
- * The exclusion band for receivers shall be calculated by using the following formulae:
 For the lower edge for the exclusion band: $EXband(lower) = Band_{RX}(lower) - ChW_{RX}$
 For the upper edge of the exclusion band: $EXband(upper) = Band_{RX}(upper) + ChW_{RX}$
- * UTRA Channel Width 5MHz

NOTE:

1. For normal operating function: There was no change compared with the initial operation during and after the test.
2. For the BER Measurement: During the test, the measured BER shall not exceed 0.001 during the test sequence.
3. Test mode 3 was the worst case and only this mode was presented in the report.



TEST VOLTAGE	Input 230 Vac, 50 Hz	ENVIRONMENTAL CONDITIONS	23deg. C, 52% RH
TEST MODE	5 ~ 10	TESTED BY	David Yuan

Field Strength (V/m)	Test Frequency Note#1 (MHz)	Polarization of antenna (Horizontal / Vertical)	Azimuth (°)	Test Distance (m)	Performance Criterion	Test Result
3	80 - 6000	H&V	0/90/180/270	3	CONTINUOUS PHENOMENA	Complied

- * The exclusion band for transmitters is 250 % of the channel width either side of the nominal operating frequency of the transmitter.
- * The exclusion band for receivers shall be calculated by using the following formulae:
 For the lower edge for the exclusion band: $EXband(lower) = Band_{RX}(lower) - ChW_{RX}$
 For the upper edge of the exclusion band: $EXband(upper) = Band_{RX}(upper) + ChW_{RX}$
- * UTRA Channel Width 5MHz

NOTE:

1. For normal operating function: There was no change compared with the initial operation during and after the test.
2. For throughput Measurement: During the test, the measured Throughput shall not found less than 95% of the maximum throughput of the reference measurement channel.
3. Test mode 5 was the worst case and only this mode was presented in the report.



TEST VOLTAGE	Input 230 Vac, 50 Hz	ENVIRONMENTAL CONDITIONS	21.5deg. C, 50.6% RH
TEST MODE	11 ~ 12	TESTED BY	David Yuan

Field Strength (V/m)	Test Frequency Note#1 (MHz)	Polarization of antenna (Horizontal / Vertical)	Azimuth (°)	Test Distance (m)	Performance Criterion	Test Result
3	80 - 6000	H&V	0/90/180/270	3	CONTINUOUS PHENOMENON A	Complied

- * The exclusion band for the transmitter and / or receiver part of the 2.4 GHz band equipment under test shall extend from 2280 MHz to 2603.5 MHz.,
- * The exclusion band for the transmitter and / or receiver part of the 5 GHz band equipment under test shall extend from 4830 MHz to 6000 MHz.,

NOTE:

1. There was no change compared with initial operation during and after the test.
2. During the test, the minimum performance level (PER of BT/wifi) was tested less than 10 %,so it meets the requirements of Performance criteria A in chapters 4.2.(For Wifi PER monitoring test,we monitored the PER via ping-command between PC and EUT.And for BT PER monitoring test,we build the link between the EUT and CMW500 to monitor the packet transmitting.)

TEST VOLTAGE	Input 230 Vac, 50 Hz	ENVIRONMENTAL CONDITIONS	21.5deg. C, 50.6% RH
TEST MODE	11 ~ 15	TESTED BY	David Yuan

Field Strength (V/m)	Test Frequency Note#1 (MHz)	Polarization of antenna (Horizontal / Vertical)	Azimuth (°)	Test Distance (m)	Performance Criterion	Test Result
3	80 - 6000	H&V	0/90/180/270	3	CONTINUOUS PHENOMENON A	Complied

NOTE:

* GNSS exclusion bands

The exclusion band for immunity testing of equipment operating in the 1559 MHz-1610MHz band shall be:

1. lower limit of exclusion band=1 492 MHz (-67 MHz of the lowest band edge frequency)
2. upper limit of exclusion band=1706 MHz (+96 MHz of the highest band edge frequency)

NOTE:

1. There was no change compared with initial operation during and after the test.



4.4.7 DATA TRANSFER MEASUREMENT RESULTS

Worst case of the test modes:

For BER

Mode 3

Horizontal (0 degree)

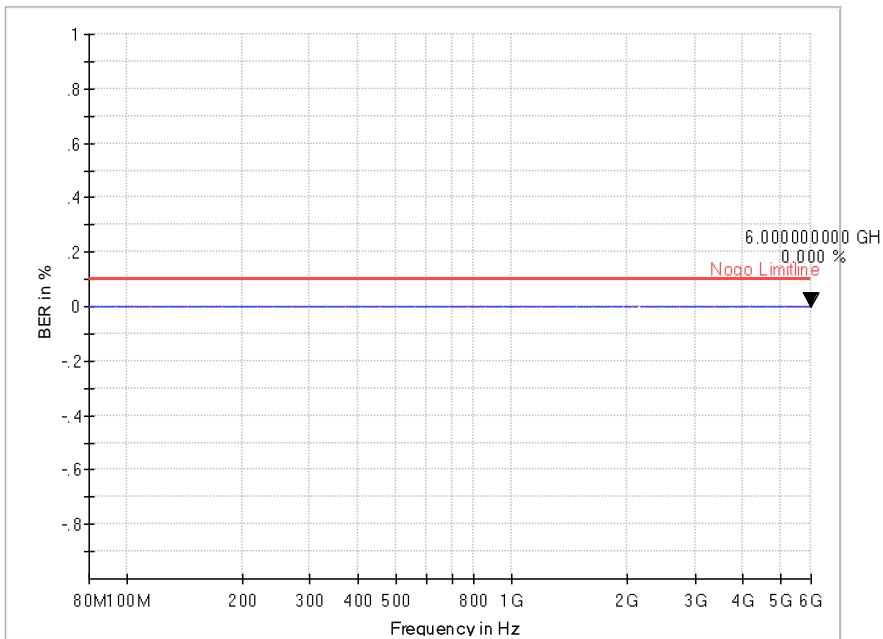



Worst case of the test modes:

For Throughput

Mode 5

Horizontal (0 degree)

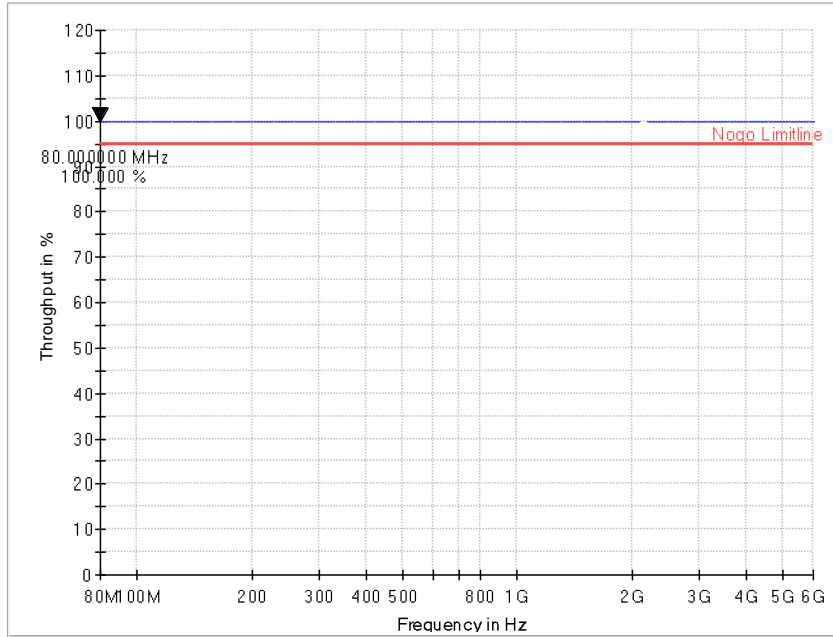



4.5 ELECTRICAL FAST TRANSIENT (EFT)

4.5.1 TEST SPECIFICATION

Basic Standard:	EN 61000-4-4
Test Voltage:	Input AC Power ports: ±1 kV wired network ports: ±0.5 kV
EFT Input/Output:	L,N,L-N
Polarity:	Positive & Negative
Impulse Repetition Frequency:	others: 5 kHz
Impulse Waveshape:	T_r/T_h 5/50 ns
Burst Duration:	15 ms for 5 kHz Repetition Frequency 0.75 ms for 100 kHz Repetition Frequency
Burst Period:	300 ms
Test Duration:	1 min

4.5.2 TEST INSTRUMENT

Equipment	Manufacturer	Model No.	Serial No.	Last Cal.	Next Cal.
Surge Pulse for power port	TESEQ	CWM 3650	3053	May. 30,23	May. 29,24
Surge Pulse for RJ45/RJ11 port	TESEQ	TSM 3751	1086	May. 30,23	May. 29,24
EFT/Burst Module for power port	TESEQ	FTM 3425-60	3298	May. 30,23	May. 29,24
EFT CDN Clamp for DATA LINE	TESEQ	CDN 3425	1985	May. 30,23	May. 29,24
DIP KIT	TESEQ	VAR-3005-S16	890	May. 31,23	May. 30,24
EFT check voltage	TESEQ	CAS 3025	40446	May. 06,23	May.05,24
surge check voltage	TESEQ	MD 200A	152841	May. 06,23	May.05,24
CDN-UTP8	EMC PARTNER	CDN-UTP8 E03-1596	106326	Aug. 11,23	Aug. 10, 24
Coupling/Decoupling Network	N/A	CDN-RJ11	10238-1	Aug. 11,23	Aug. 10, 24
Coupling/Decoupling Network	N/A	CDN-RJ45	20013-1	Aug. 11,23	Aug. 10, 24

NOTE: 1. The test was performed in EMS Room.
 2. The calibration interval of the above test instruments is 12 months and the calibrations are traceable to CEPREI/CHINA, GRGT/CHINA and NIM/CHINA.



4.5.3 TEST PROCEDURE

- a. Both positive and negative polarity discharges were applied.
- b. The distance between any coupling devices and the EUT should be $(0.5 - 0/+0.1)$ m for table-top equipment testing, and (1.0 ± 0.1) m for floor standing equipment.
- c. The duration time of each test sequential was 1 minute.
- d. The transient/burst waveform was in accordance with EN 61000-4-4, 5/50ns.

4.5.4 DEVIATION FROM TEST STANDARD

No deviation.

4.5.5 TEST SETUP

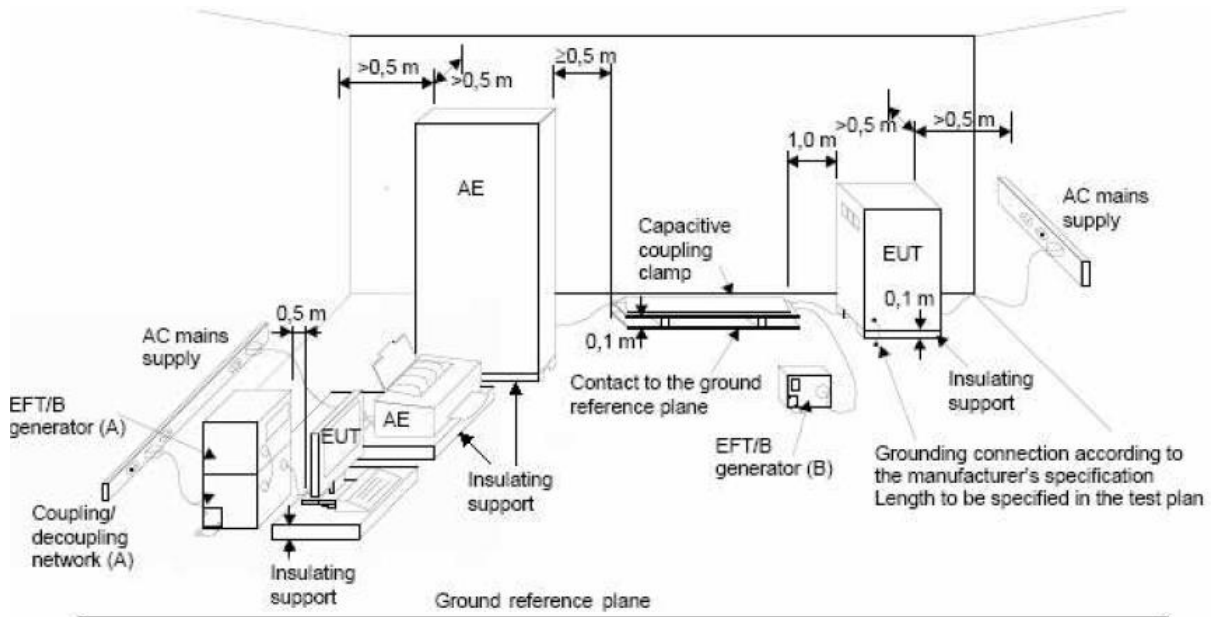

(A) location for supply line coupling

(B) location for signal lines coupling

For the actual test configuration, please refer to the related item – Photographs of the Test Configuration.



4.5.6 TEST RESULTS

TEST VOLTAGE	Input 230 Vac, 50 Hz	ENVIRONMENTAL CONDITIONS	24deg. C, 48% RH
TEST MODE	See section 2.2	TESTED BY	Carl xie

Test Point	Polarity	Test Level (kV)	Observation	Performance Criterion	Test Result
L	+/-	1	NOTE	TRANSIENT PHENOMENA	Complied
N	+/-	1	NOTE	TRANSIENT PHENOMENA	Complied
L – N	+/-	1	NOTE	TRANSIENT PHENOMENA	Complied

NOTE: There was no change compared with initial operation during and after the test.



4.6 SURGE IMMUNITY

4.6.1 TEST SPECIFICATION

Basic Standard:	EN 61000-4-5
Wave-Shape:	Input AC power port: 1.2/50 μ s Open Circuit Voltage 8/20 μ s Short Circuit Current Wired network ports: 10/700 μ s Open Circuit Voltage
Test Voltage:	Input AC power ports: Line to line: ± 1 kV wired network ports: lines to ground: ± 1 kV, lines to lines: ± 0.5 kV
Surge Input/Output:	L-N, L-GND
Generator Source Impedance:	2 ohm between networks
Polarity:	Positive/Negative
Phase Angle:	0°/90°/180°/270°
Pulse Repetition Rate:	1 time / 60 sec.
Number of Tests:	5 positive and 5 negative at selected points

4.6.2 TEST INSTRUMENT

Refer to section 4.5.2 to get information of above instrument.



4.6.3 TEST PROCEDURE

a. For EUT power supply:

The surge is applied to the EUT power supply terminals via the capacitive coupling network. Decoupling networks are required in order to avoid possible adverse effects on equipment not under test that may be powered by the same lines, and to provide sufficient decoupling impedance to the surge wave. The power cord between the EUT and the coupling/decoupling networks was shorter than 2 meters in length.

For double-insulated products without PE or external earth connections, the test shall be done in a similar way as for grounded products but without adding any additional external grounded connections. If there are no other possible connections to earth, line-to-ground tests may be omitted.

b. Signal and telecommunication ports,

Unshielded unsymmetrical interconnection lines:

The surge is applied to the lines via the capacitive coupling. The coupling / decoupling networks shall not influence the specified functional conditions of the EUT. The interconnection line between the EUT and the coupling/decoupling networks shall be 2 meters in length.

Unshielded symmetrical interconnections communication lines:

The surge is applied to the lines via gas arrestors coupling. Test levels below the ignition point of the coupling arrestor cannot be specified. The interconnection line between the EUT and the coupling/decoupling networks shall be 2 meters in length.

High speed communications lines

Prior to the test, the correct operation of the port shall be verified; the external connection shall then be removed and the surge applied directly to the port's terminals with no coupling /decoupling network. After the surge, the correct operation of the port shall again be verified.

Shielded lines:

- Direct application,

The EUT is isolated from ground and the surge is applied to its metallic enclosure; the termination (or auxiliary equipment) at the port(s) under test is grounded. This test applies to equipment with single or multiple shielded cables.

Rules for application of the surge to shielded lines:

- a) Shields grounded at both ends

- > The surge injection on the shield.

Test Report No.: W7L-P23120016EM01

b) Shields grounded at one end

- > If in the installation the shield is connected only at the auxiliary equipment, test shall be done in that configuration but with the generator still connected to the EUT side. If cable lengths allow, the cables shall be on insulated supports 0,1 m above the ground plane or cable tray.

For products which do not have metallic enclosures, the surge is applied directly to the shielded cable.

- Alternative coupling method for testing single cables in a multi-shield configuration,

Surges are applied in close proximity to the interconnection cable under test by a wire. The length of the cable between the port(s) under test and the device attached to the other end of the cable shall be the lesser of: the maximum length permitted by the EUT's specification, or 20 m. Where the length exceeds 1 m, excess lengths of cables shall be bundled at the approximate centre of the cables with the bundles 30 cm to 40 cm in length.

4.6.4 DEVIATION FROM TEST STANDARD

No deviation.

4.6.5 TEST SETUP

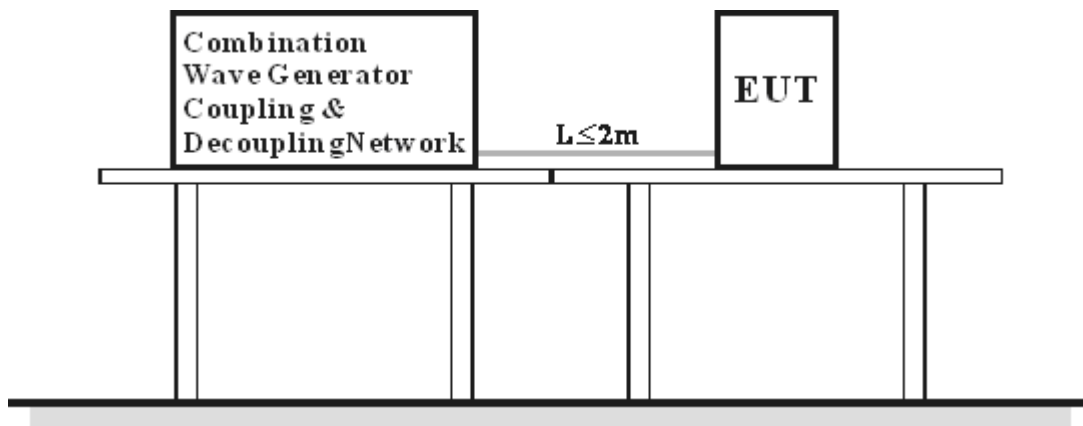

For the actual test configuration, please refer to the related item – Photographs of the Test Configuration.



4.6.6 TEST RESULTS

TEST VOLTAGE	Input 230 Vac, 50 Hz	ENVIRONMENTAL CONDITIONS	23deg. C, 54% RH
TEST MODE	See section 2.2	TESTED BY	Carl xie

AC Power port:

\Phase angle \ Test result \Voltage (kV) \ Test point\ Polarity			0°	90°	180°	270°	Performance Criterion	Test Result
1	L-N	+	PASS	PASS	PASS	PASS	TRANSIENT PHENOMENA	Complied
		-	PASS	PASS	PASS	PASS	TRANSIENT PHENOMENA	Complied

NOTE: There was no change compared with initial operation during and after the test.



4.7 CONDUCTED RADIO FREQUENCY DISTURBANCES (CS)

4.7.1 TEST SPECIFICATION

Basic Standard:	EN 61000-4-6
Frequency Range:	0.15 MHz ~ 80 MHz
Field Strength:	3 Vrms
Modulation:	1 kHz Sine Wave, 80%, AM Modulation
Frequency Step:	1 % of preceding frequency value
Coupled cable:	Power Mains, Unshielded, wired network ports
Coupling device:	CDN-M2, CDN-RJ45

4.7.2 TEST INSTRUMENT

Equipment	Manufacturer	Model No.	Serial No.	Last Cal.	Next Cal.
Current Injection	Rohde&Schwarz	F-120-9A	160178	Feb. 14,23	Feb. 13,24
Current Injection	Rohde&Schwarz	F-120-9A	160178	Feb. 13,24	Feb. 12,25
Current Probe	Rohde&Schwarz	F-52	160179	Feb. 14,23	Feb. 13,24
Current Probe	Rohde&Schwarz	F-52	160179	Feb. 13,24	Feb. 12,25
Base station R&S CMU200	Rohde&Schwarz	CMU200	119991	Aug. 13,23	Aug. 12, 24
Audio Analyzer	Rohde&Schwarz	UPV	104033	Feb. 14,23	Feb. 13,24
Audio Analyzer	Rohde&Schwarz	UPV	104033	Feb. 13,24	Feb. 12,25
CS Test System TS9986	Rohde&Schwarz	SMC100A +SMC-B101	104982	Feb. 14,23	Feb. 13,24
CS Test System TS9986	Rohde&Schwarz	SMC100A +SMC-B101	104982	Feb. 13,24	Feb. 12,25
POWER AMPLIFIER_CS	Rohde&Schwarz	BBA100-A125C125	101804	Feb. 14,23	Feb. 13,24
POWER AMPLIFIER_CS	Rohde&Schwarz	BBA100-A125C125	101804	Feb. 13,24	Feb. 12,25
CDN	Rohde&Schwarz	FCC-801-M2/M3-1 6A	160181	Feb. 14,23	Feb. 13,24
CDN	Rohde&Schwarz	FCC-801-M2/M3-1 6A	160181	Feb. 13,24	Feb. 12,24
BCI Impedance	Rohde&Schwarz	FCC-801-150-50-B CI	160185	Feb. 14,23	Feb. 13,24
BCI Impedance	Rohde&Schwarz	FCC-801-150-50-B CI	160185	Feb. 13,24	Feb. 12,25
CDN	Rohde&Schwarz	FCC-801-150-50-C DN-ED4	160182	Feb. 14,23	Feb. 13,24
CDN	Rohde&Schwarz	FCC-801-150-50-C DN-ED4	160182	Feb. 13,24	Feb. 12,25
calibration Fixture	Rohde&Schwarz	FCC-BCICF-6-150	160184	Feb. 14,23	Feb. 13,24
calibration Fixture	Rohde&Schwarz	FCC-BCICF-6-150	160184	Feb. 13,24	Feb. 12,25
Proble Kit	Rohde&Schwarz	FCC-MPCF-3-F-52	160180	Feb. 14,23	Feb. 13,24
Proble Kit	Rohde&Schwarz	FCC-MPCF-3-F-52	160180	Feb. 13,24	Feb. 12,25
Coupling-decoupling network-T4AS	TESEQ	CDN T4AS	N/A	Feb. 14,23	Feb. 13,24
Coupling-decoupling network-T4AS	TESEQ	CDN T4AS	N/A	Feb. 13,24	Feb. 12,25



Ear Simulator	Rohde&Schwarz	4182	2959480	NA	NA
Mouth Simulator	Rohde&Schwarz	4227	2837779	Sep. 29,23	Sep. 28,24
conditioning Amplifier	Rohde&Schwarz	Type 5935	2997235	Feb. 24,23	Feb. 23,24
power sensor	Rohde&Schwarz	NRP-Z91	102958	Aug. 11,23	Aug. 10, 24

NOTE: 1. The test was performed in CS Room.

2. The calibration interval of the above test instruments is 12 months and the calibrations are traceable to CEPREI/CHINA, GRGT/CHINA and NIM/CHINA.



4.7.3 TEST PROCEDURE

- a. The EUT shall be tested within its intended operating and climatic conditions.
- b. An artificial hand was placed on the hand-held accessory and connected to the ground reference plane.
- c. One of the CDNs not used for injection was terminated with 50Ω, providing only one return path. All other CDNs were coupled as decoupling networks.
- d. The frequency range is swept from 150 kHz to 80 MHz, using the signal level established during the setting process and with a disturbance signal of 80 % amplitude. The signal is modulated with a 1 kHz sine wave, pausing to adjust the RF signal level or the switch coupling devices as necessary. Where the frequency is swept incrementally, the step size shall not exceed 1% of the preceding frequency value.
- e. The dwell time of the amplitude modulated carrier at each frequency shall not be less than the time necessary for the EUT to be exercised and to respond, but shall in no case be less than 0.5 s. The sensitive frequencies (e.g. clock frequencies) shall be analyzed separately.
- f. Attempts should be made to fully exercise the EUT during testing, and to fully interrogate all exercise modes selected for susceptibility.

4.7.4 DEVIATION FROM TEST STANDARD

No deviation.

4.7.5 TEST SETUP

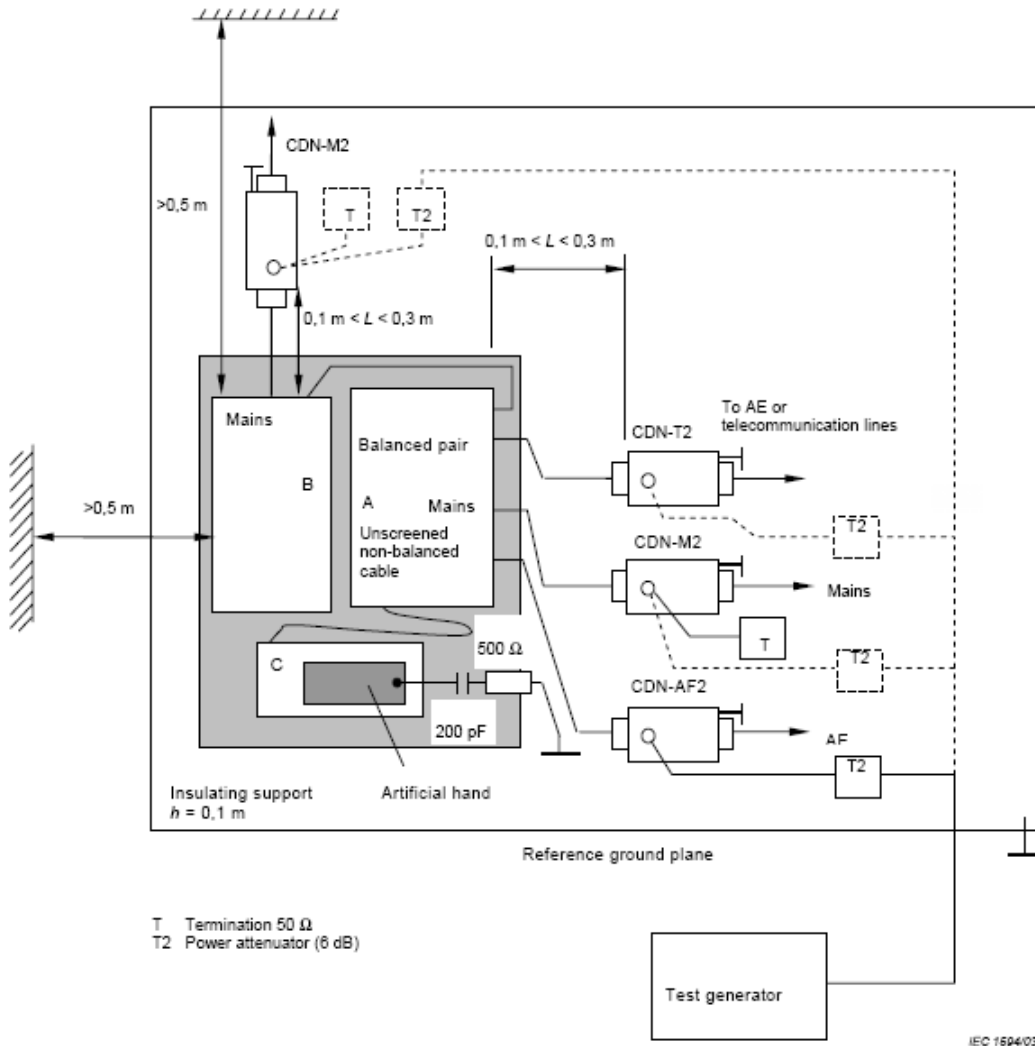

- Note:**
1. The EUT clearance from any metallic obstacles shall be at least 0.5 m.
 2. Interconnecting cables (≤ 1 m) belonging to the EUT shall remain on the insulating support.

For the actual test configuration, please refer to the related item – Photographs of the Test Configuration.

NOTE:

The equipment to be tested is placed on an insulating support of 0.1 meters height above a ground reference plane. All relevant cables shall be provided with the appropriate coupling and decoupling devices at a distance between 0.1 meters and 0.3 meters from the projected geometry of the EUT on the ground reference plane.



4.7.6 TEST RESULTS

TEST VOLTAGE	Input 230 Vac, 50 Hz	ENVIRONMENTAL CONDITIONS	22.4deg. C, 50.2% RH
TEST MODE	1 ~ 2	TESTED BY	Carl xie

Voltage (V)	Test Frequency Note#1 (MHz)	Tested Line	Injection Method.	Performance Criterion	Test Result
3	0.15 – 80	AC line	CDN-M2	CONTINUOUS PHENOMENA	Complied

NOTE:

1. For normal operating function: There was no change compared with the initial operation during and after the test.

TEST VOLTAGE	Input 230 Vac, 50 Hz	ENVIRONMENTAL CONDITIONS	22.4deg. C, 50.2% RH
TEST MODE	3 ~ 4	TESTED BY	Carl xie

Voltage (V)	Test Frequency Note#1 (MHz)	Tested Line	Injection Method.	Performance Criterion	Test Result
3	0.15 – 80	AC line	CDN-M2	CONTINUOUS PHENOMENA	Complied

NOTE:

1. For normal operating function: There was no change compared with the initial operation during and after the test.
2. For the BER Measurement: During the test, the measured BER shall not exceed 0.001 during the test sequence.
3. Test mode 3 was the worst case and only this mode was presented in the report.



TEST VOLTAGE	Input 230 Vac, 50 Hz	ENVIRONMENTAL CONDITIONS	22.4deg. C, 50.2% RH
TEST MODE	5 ~10	TESTED BY	Carl xie

Voltage (V)	Test Frequency Note#1 (MHz)	Tested Line	Injection Method.	Performance Criterion	Test Result
3	0.15 – 80	AC line	CDN-M2	CONTINUOUS PHENOMENA	Complied

NOTE:

1. For normal operating function: There was no change compared with the initial operation during and after the test.
2. For the Throughput Measurement: During the test, the measured Throughput shall not found less than 95% of the maximum throughput of the reference measurement channel.
3. Test mode 5 was the worst case and only this mode was presented in the report.

TEST VOLTAGE	Input 230 Vac, 50 Hz	ENVIRONMENTAL CONDITIONS	22.4deg. C, 50.2% RH
TEST MODE	11 ~ 12	TESTED BY	Carl xie

Voltage (V)	Test Frequency Note#1 (MHz)	Tested Line	Injection Method.	Performance Criterion	Test Result
3	0.15 – 80	AC line	CDN-M2	CONTINUOUS PHENOMENA	Complied

NOTE:

1. During the test, the minimum performance level (PER of BT/wifi) was tested less than 10 %,so it meets the requirements of Performance criteria A in chapters 4.2.(For Wifi PER monitoring test,we monitored the PER via ping-command between PC and EUT.And for BT PER monitoring test,we build the link between the EUT and CMW500 to monitor the packet transmitting.)
2. There was no change compared with the initial operation during and after the test.



TEST VOLTAGE	Input 230 Vac, 50 Hz	ENVIRONMENTAL CONDITIONS	22.4deg. C, 50.2% RH
TEST MODE	13 ~ 15	TESTED BY	Carl xie

Voltage (V)	Test Frequency Note#1 (MHz)	Tested Line	Injection Method.	Performance Criterion	Test Result
3	0.15 – 80	AC line	CDN-M2	CONTINUOUS PHENOMENA	Complied

1. There was no change compared with the initial operation during and after the test.



4.7.7 DATA TRANSFER MEASUREMENT RESULTS

Worst case of the test modes:

For BER

Mode 3

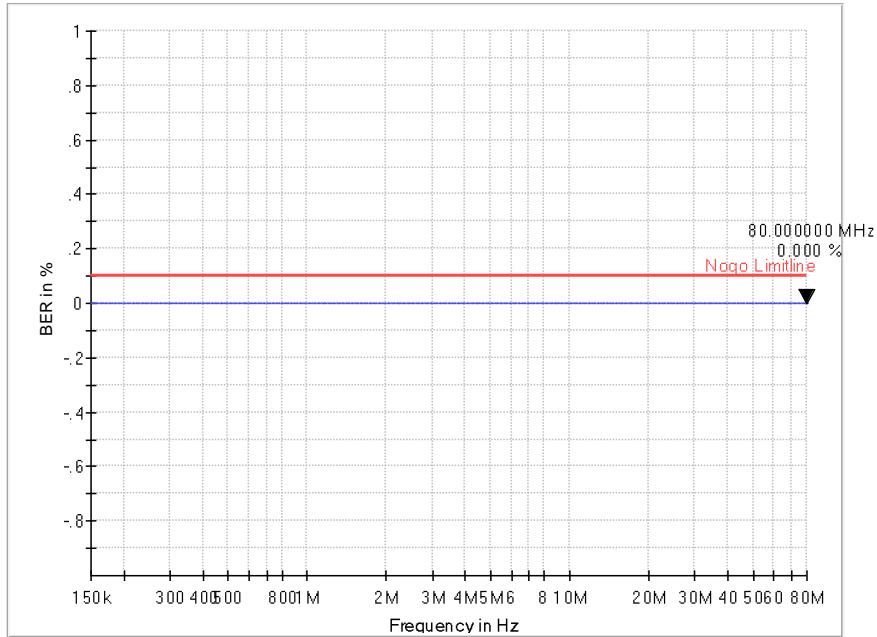



BUREAU
VERITAS

Test Report No.: W7L-P23120016EM01

**For Throughput
Mode 5**

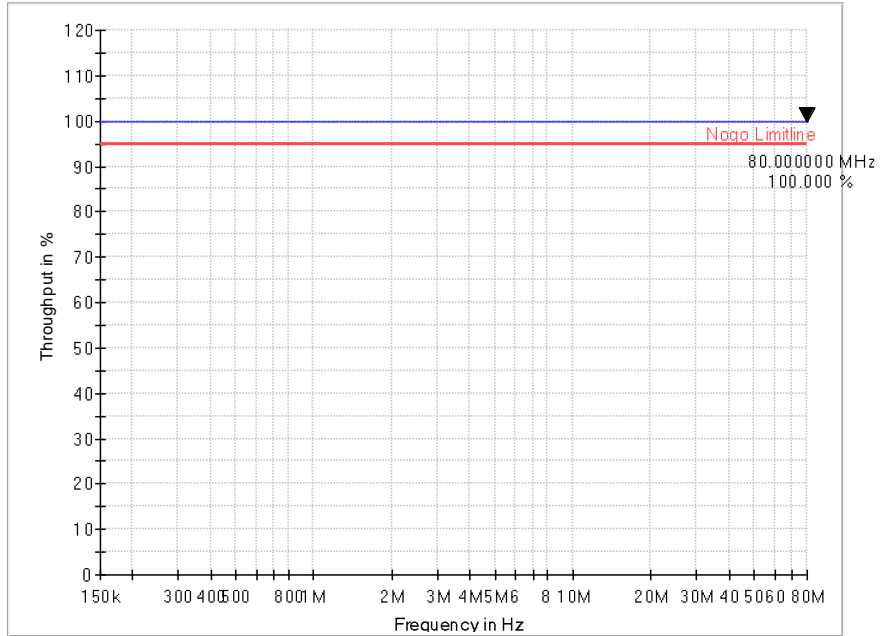



4.8 VOLTAGE DIP/SHORT INTERRUPTIONS/VOLTAGE VARIATIONS (DIP) IMMUNITY TEST

4.8.1 TEST SPECIFICATION

Basic Standard: EN 61000-4-11

Test Levels: Voltage Dips:

0% residual voltage for 0.5 cycle

0% residual voltage for 1 cycle

70% residual voltage for 25 cycles

Voltage Interruptions:

0% residual voltage for 250 cycles

Interval between Event: 10 seconds

Phase Angle: 0° / 180°

Test cycle: 3 times

4.8.2 TEST INSTRUMENT

Refer to section 4.5.2 to get information of above instrument.

4.8.3 TEST PROCEDURE

The EUT was tested for each selected combination of test levels and duration with a sequence of three dips/interruptions with intervals of 10s minimum (between each test event). Each representative mode of operation shall be tested. Abrupt changes in supply voltage shall occur at zero crossings of the voltage waveform.

4.8.4 DEVIATION FROM TEST STANDARD

No deviation.



4.8.5 TEST SETUP

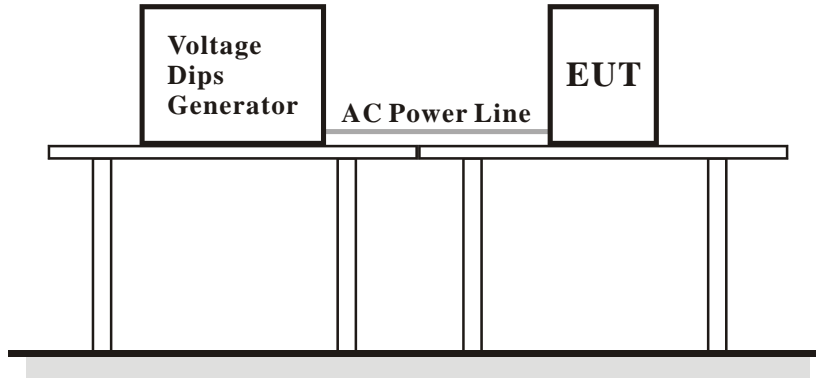

For the actual test configuration, please refer to the related item – Photographs of the Test Configuration.



4.8.6 TEST RESULTS

TEST VOLTAGE	Input 230 Vac, 50 Hz	ENVIRONMENTAL CONDITIONS	24deg. C, 48% RH
TEST MODE	See section 2.2	TESTED BY	Carl xie

Ut : <u>230</u> Vac <u>50</u> Hz voltage residual (%)	Durations		Event interval (sec)	Total events (time)	Performance Criterion	Test result
	(period)	(ms)				
0	0.5	10	10	3	TRANSIENT PHENOMENA	Complied
0	1	20	10	3	TRANSIENT PHENOMENA	Complied
70	25	500	10	3	TRANSIENT PHENOMENA	Complied
0	250	5000	10	3	TRANSIENT PHENOMENA	Complied

NOTE: There was no change compared with the initial operation during and after the test.



5 PHOTOGRAPHS OF THE TEST CONFIGURATION

Conducted Emission Test

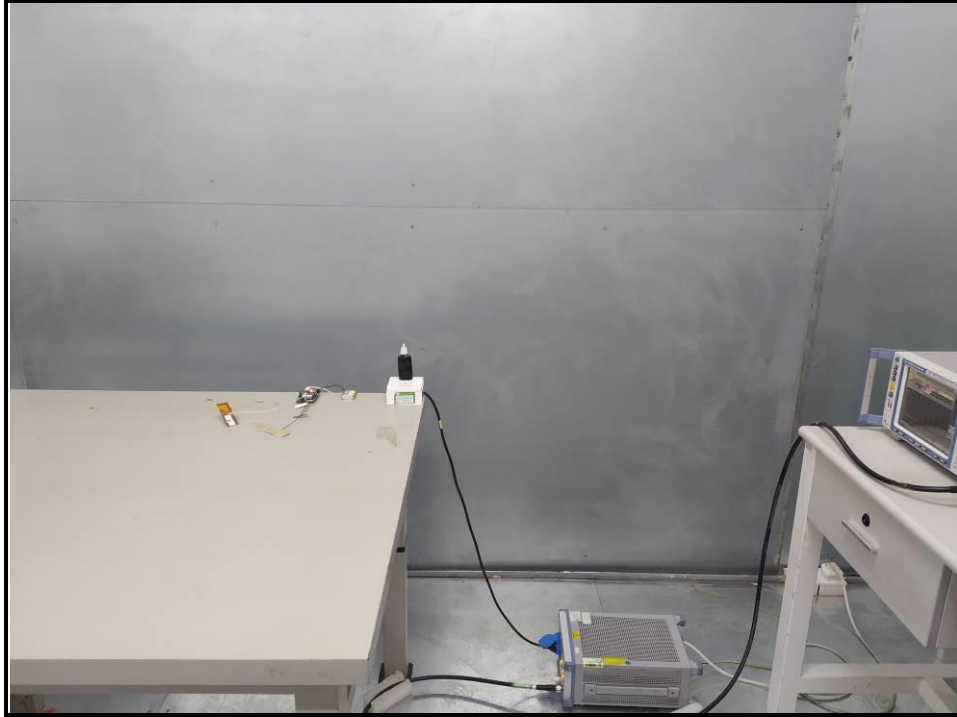

Radiated Emission Test (Frequency range 30MHz ~1GHz)

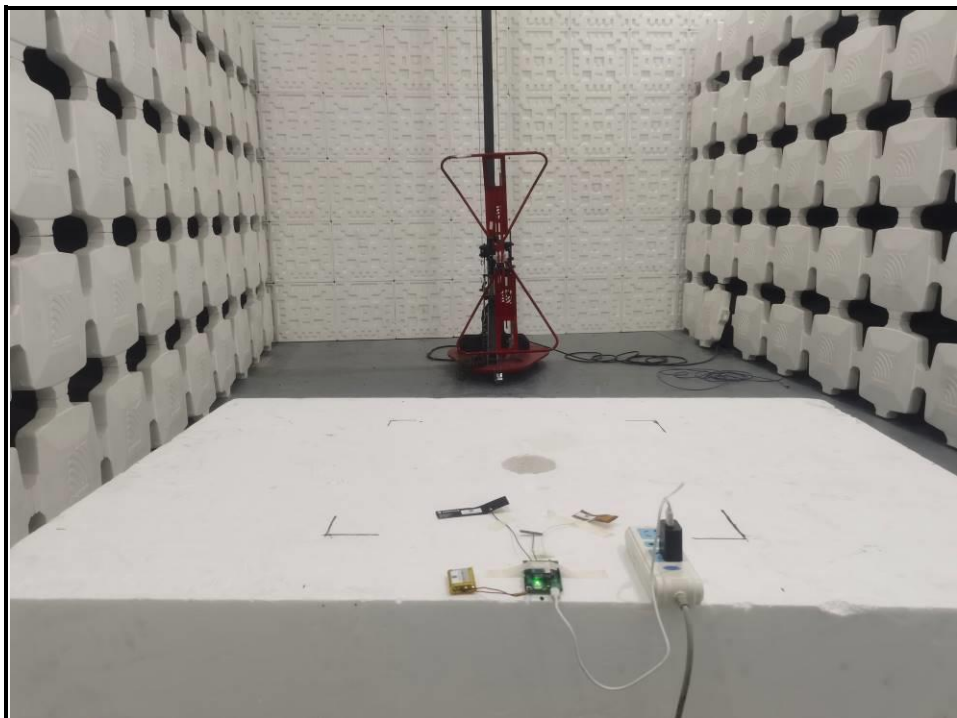
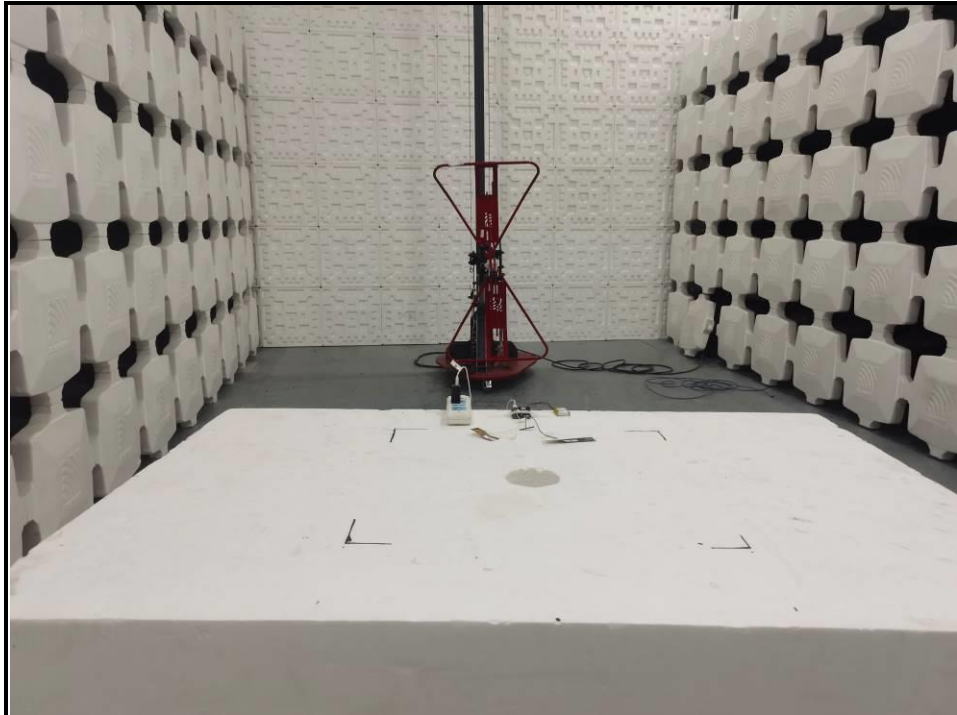

Radiated Emission Test (Frequency range above 1GHz)

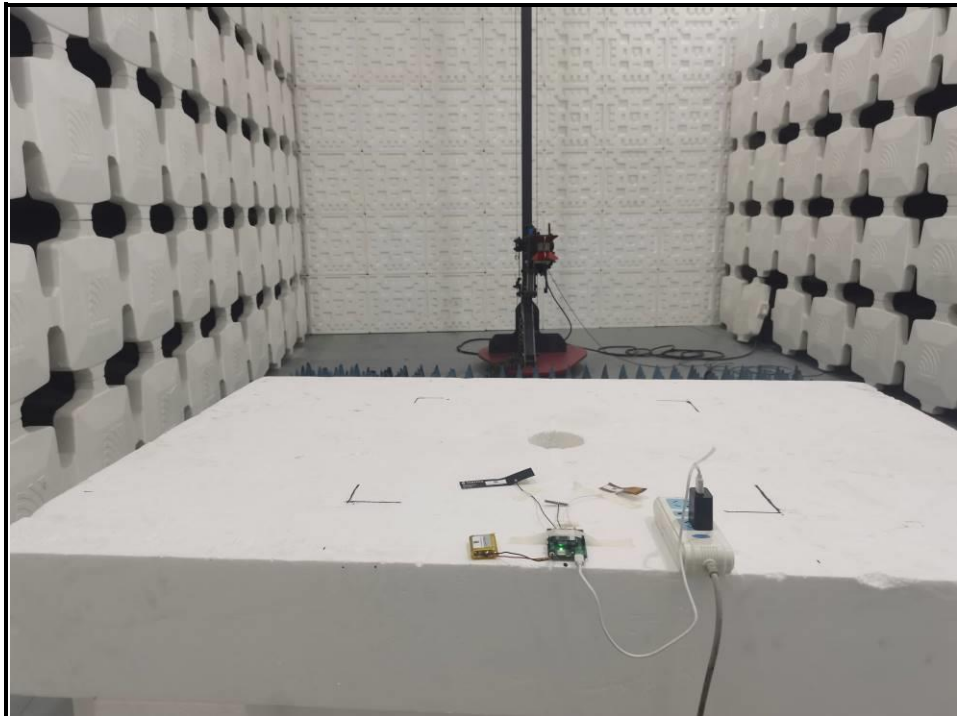
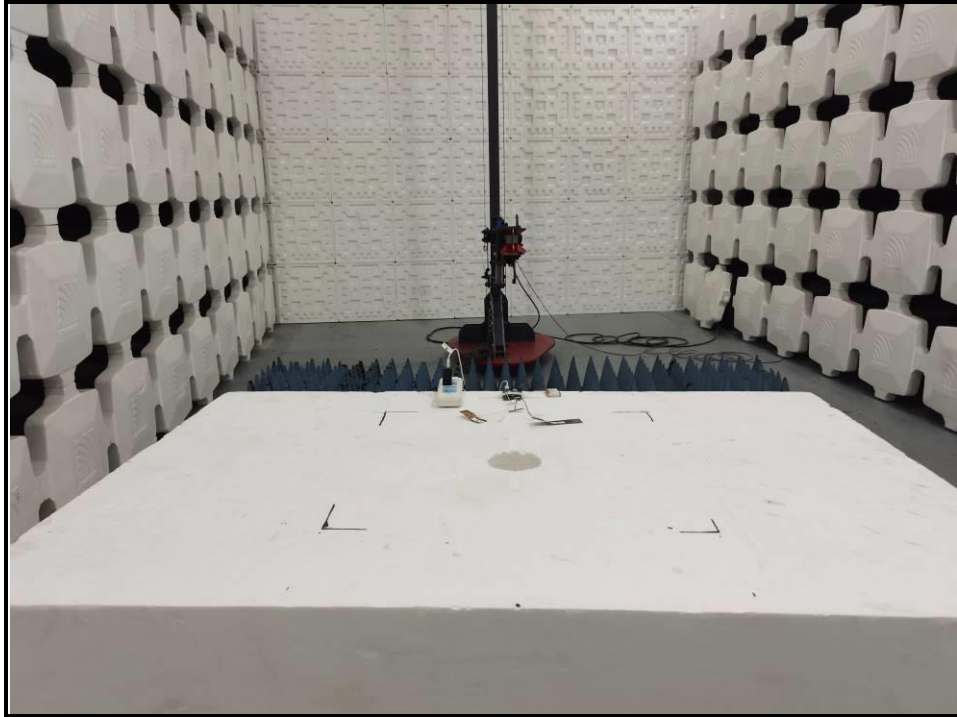

Flicker Test

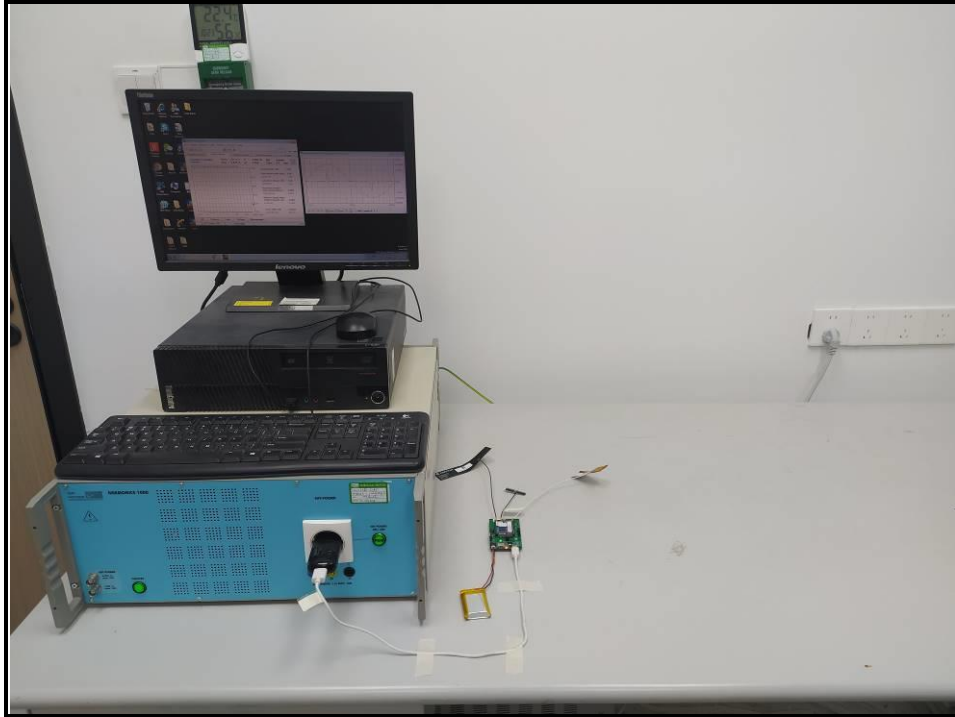

RS Test



ESD Test



EFT Test

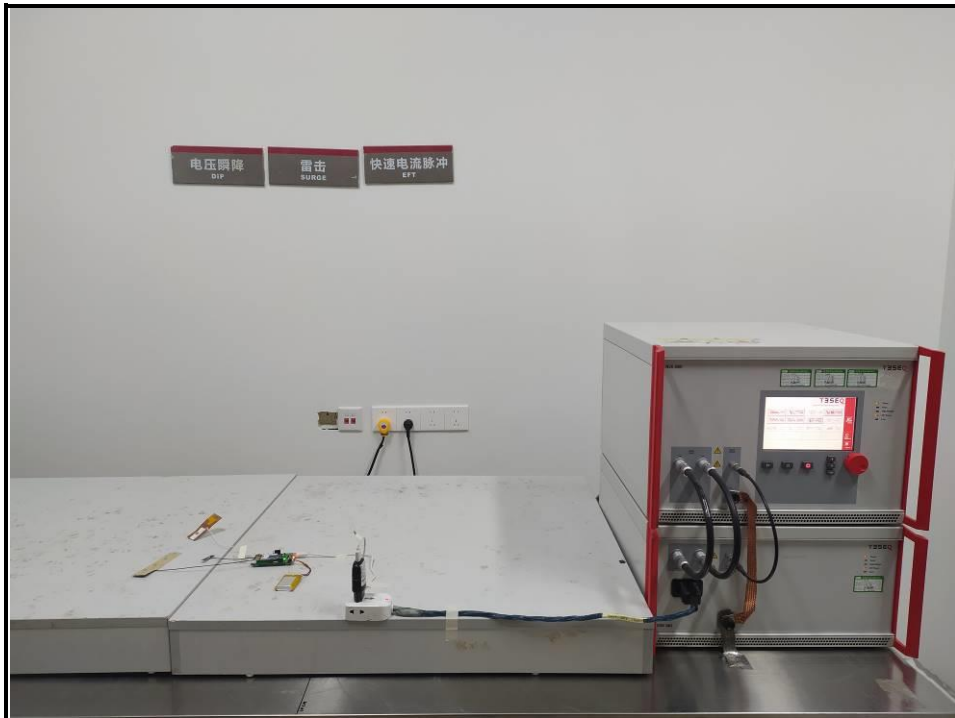

Surge Test

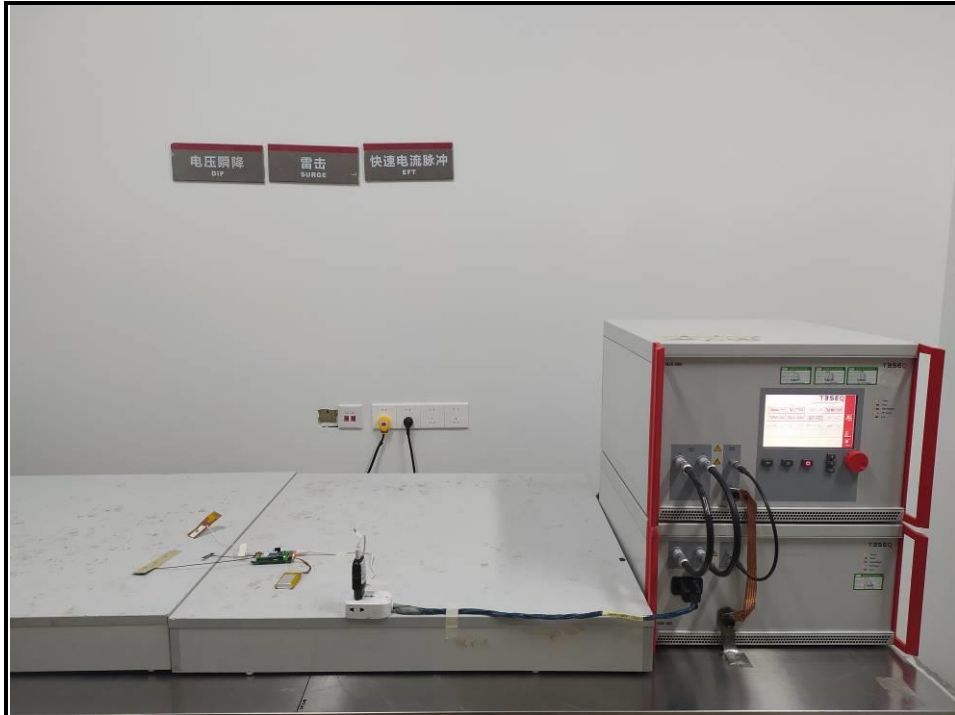

CS Test

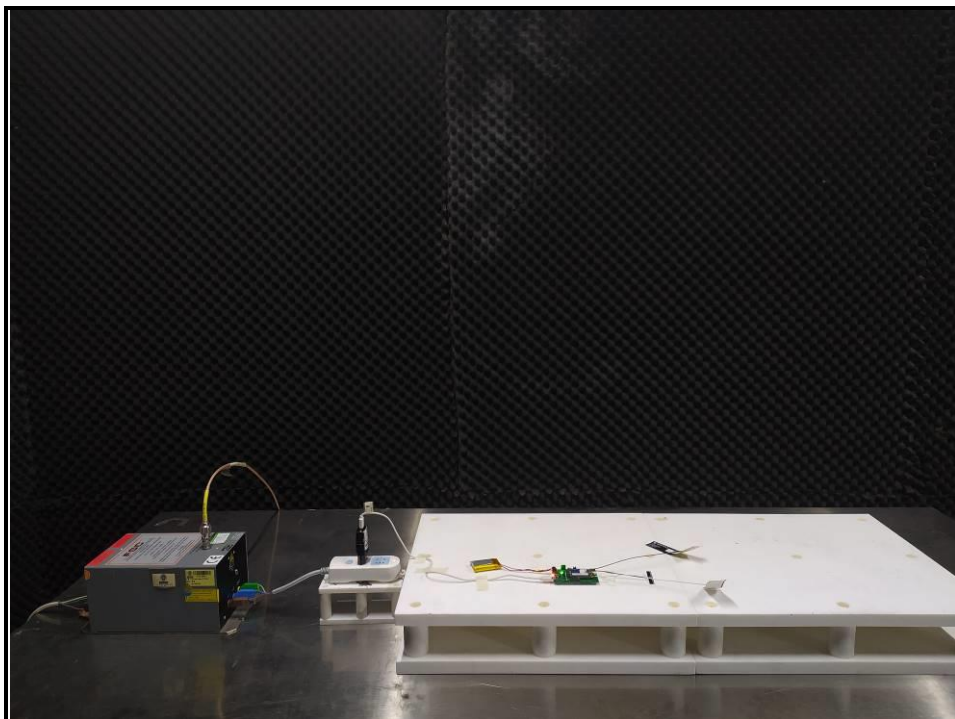

Voltage Dip and Interruption Test

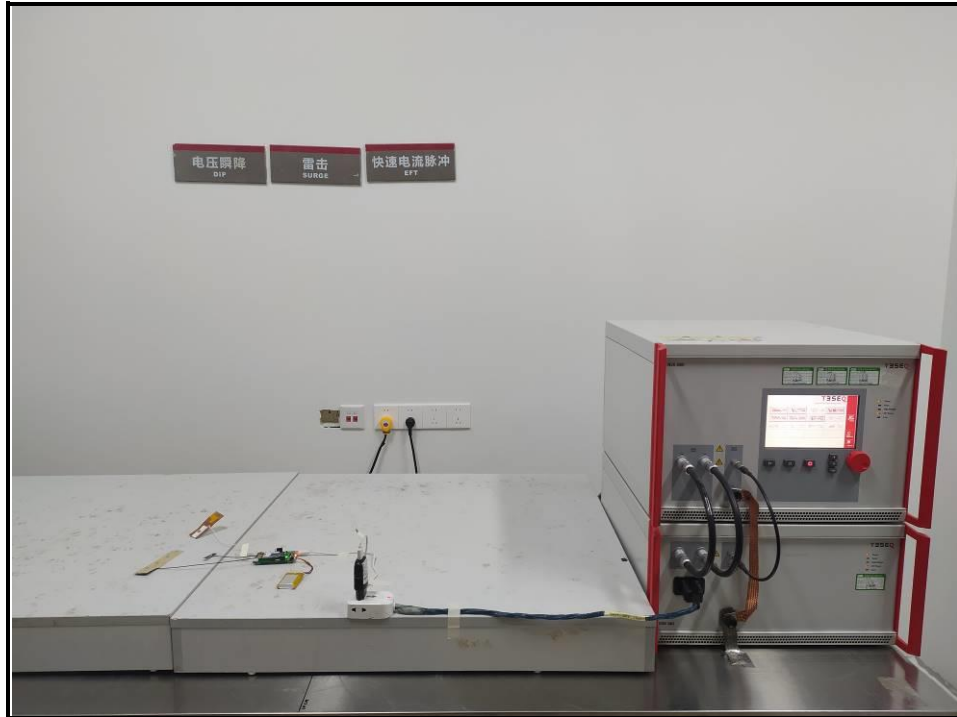



**BUREAU
VERITAS**

Test Report No.: W7L-P23120016EM01

6 APPENDIX A – MODIFICATIONS RECORDERS FOR ENGINEERING CHANGES TO THE EUT BY THE LAB

No any modifications were made to the EUT by the lab during the test.

---END---