



BUREAU
VERITAS

Test Report No.: W7L-P23100004RI02



IC TEST REPORT

(RSS- 132)



Applicant:	Particle Industries, Inc
Address:	325 9th Street, San Francisco, CA 94103, United States Of America

Manufacturer or Supplier:	Particle Industries, Inc
Address:	325 9th Street, San Francisco, CA 94103, United States Of America
Product:	Montior One DE
Brand Name:	Particle
Model Name:	MON404-DE
IC:	20127-MONEDE
Date of tests:	Oct. 11, 2023 ~ Oct. 20, 2023

The tests have been carried out according to the requirements of the following standard:

- RSS-132 Issue 4, January 31, 2023**
- RSS-Gen Issue 5, Amendment 1, March 2019**
- ANSI C63.26-2015**

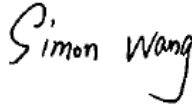
CONCLUSION: The submitted sample was found to COMPLY with the test requirement

Prepared by Simon Wang Engineer / Mobile Department	Approved by Luke Lu Manager / Mobile Department
	
Date: Oct. 20, 2023	Date: Oct. 20, 2023

This report is governed by, and incorporates by reference, the Conditions of Testing as posted at the date of issuance of this report at <http://www.bureauveritas.com/home/about-us/our-business/cps/about-us/terms-conditions>, and is intended for your exclusive use. Any copying or replication of this report to or for any other person or entity, or use of our name or trademark, is permitted only with our prior written permission. This report sets forth our findings solely with respect to the test samples identified herein. The results set forth in this report are not indicative or representative of the quality or characteristics of the lot from which a test sample was taken or any similar or identical product unless specifically and expressly noted. Our report includes all of the tests requested by you and the results thereof based upon the information that you provided to us. Measurement uncertainty is only provided upon request for accredited tests. Statements of conformity are based on simple acceptance criteria without taking measurement uncertainty into account, unless otherwise requested in writing. You have 60 days from date of issuance of this report to notify us of any material error or omission caused by our negligence or if you require measurement uncertainty; provided, however, that such notice shall be in writing and shall specifically address the issue you wish to raise. A failure to raise such issue within the prescribed time shall constitute your unqualified acceptance of the completeness of this report, the tests conducted and the correctness of the report contents.



TABLE OF CONTENTS

RELEASE CONTROL RECORD4

1 SUMMARY OF TEST RESULTS5

1.1 MEASUREMENT UNCERTAINTY6

1.2 TEST SITE AND INSTRUMENTS7

2 GENERAL INFORMATION.....8

2.1 GENERAL DESCRIPTION OF EUT8

2.2 CONFIGURATION OF SYSTEM UNDER TEST 10

2.3 DESCRIPTION OF SUPPORT UNITS 11

2.4 TEST ITEM AND TEST CONFIGURATION..... 11

2.5 EUT OPERATING CONDITIONS..... 14

2.6 GENERAL DESCRIPTION OF APPLIED STANDARDS 14

2.7 TRANSMIT ANTENNA 14

3 TEST TYPES AND RESULTS15

3.1 OUTPUT POWER MEASUREMENT 15

3.1.1 LIMITS OF OUTPUT POWER MEASUREMENT 15

3.1.2 TEST PROCEDURES 15

3.1.3 TEST SETUP 16

3.1.4 TEST RESULTS 16

3.2 FREQUENCY STABILITY MEASUREMENT 22

3.2.1 LIMITS OF FREQUENCY STABILITY MEASUREMENT 22

3.2.2 TEST PROCEDURE 22

3.2.3 TEST SETUP 22

3.2.4 TEST RESULTS 23

3.3 OCCUPIED BANDWIDTH MEASUREMENT 24

3.3.1 TEST PROCEDURES 24

3.3.2 TEST SETUP 24

3.3.3 TEST RESULTS 25

3.4 BAND EDGE MEASUREMENT 26

3.4.1 LIMITS OF BAND EDGE MEASUREMENT 26

3.4.2 TEST SETUP 26

3.4.3 TEST PROCEDURES 27

3.4.4 TEST RESULTS 28

3.5 CONDUCTED SPURIOUS EMISSIONS..... 29

3.5.1 LIMITS OF CONDUCTED SPURIOUS EMISSIONS MEASUREMENT 29

3.5.2 TEST PROCEDURE 29

3.5.3 TEST SETUP 29

3.5.4 TEST RESULTS 30

3.6 RADIATED EMISSION MEASUREMENT 31

3.6.1 LIMITS OF RADIATED EMISSION MEASUREMENT 31

3.6.2 TEST PROCEDURES 31

3.6.3 DEVIATION FROM TEST STANDARD 31

3.6.4 TEST SETUP 32

3.6.5 TEST RESULTS 34

3.7 PEAK TO AVERAGE RATIO 60

3.7.1 LIMITS OF PEAK TO AVERAGE RATIO MEASUREMENT 60

3.7.2 TEST SETUP 60



**BUREAU
VERITAS**

Test Report No.: W7L-P23100004RI02

3.7.3	TEST PROCEDURES	60
3.7.4	TEST RESULTS	61
4	INFORMATION ON THE TESTING LABORATORIES	62
5	MODIFICATIONS RECORDERS FOR ENGINEERING CHANGES TO THE EUT BY THE LAB	63



BUREAU
VERITAS

Test Report No.: W7L-P23100004RI02

RELEASE CONTROL RECORD

ISSUE NO.	REASON FOR CHANGE	DATE ISSUED
W7L-P23100004RI02	Original release	Oct. 20, 2023



1 SUMMARY OF TEST RESULTS

The EUT has been tested according to the following specifications:

APPLIED STANDARD: IC RSS-132, RSS-Gen		
STANDARD SECTION	TEST TYPE AND LIMIT	RESULT
RSS-Gen		
6.7	Occupied Bandwidth	See Note
6.8	Transmit antenna	Compliance
STANDARD SECTION	TEST TYPE AND LIMIT	RESULT
RSS-132		
5.3	Frequency Stability AFC Freq. Error vs. Voltage AFC Freq. Error vs. Temperature	See Note
5.4	Maximum Peak Output Power	Compliance
5.4	peak-to-average power ratio	See Note
5.5	Band Edge Measurements	See Note
5.5	Conducted Spurious Emissions	See Note
5.5	Radiated Spurious Emissions	Compliance

NOTE: Refer to Module report R1811A0536-R7, IC:10224A-201709BG96.



1.1 MEASUREMENT UNCERTAINTY

Where relevant, the following measurement uncertainty levels have been estimated for tests performed on the EUT as specified in ETSI TR 100 028-1 V1.4.1(2001-12):

MEASUREMENT	UNCERTAINTY
Frequency Stability	±76.97Hz
Radiated emissions (9KHz~30MHz)	±2.68dB
Radiated emissions & Radiated Power (30MHz~1GHz)	±4.98dB
Radiated emissions & Radiated Power (1GHz ~6GHz)	±4.70dB
Radiated emissions (6GHz ~18GHz)	±4.60dB
Radiated emissions (18GHz ~40GHz)	±4.12dB
Conducted emissions	±4.01dB
Occupied Channel Bandwidth	±43.58KHz
Conducted Output power	±2.06dB
Band Edge Measurements	±4.70dB
Peak to average ratio	±0.76dB

This uncertainty represents an expanded uncertainty expressed at approximately the 95% confidence level using a coverage factor of k=2.

**1.2 TEST SITE AND INSTRUMENTS**

Equipment	Manufacturer	Model No.	Serial No.	Last Cal.	Next Cal.
MXE EMI Receiver	KEYSIGHT	N9038A-544	MY54450026	Mar. 28,23	Mar. 27,24
EXA Signal Analyzer	KEYSIGHT	N9010A-544	MY54510355	May.10,23	May.09,24
Loop Antenna	Schwarzbeck	FMZB 1519B	00173	Sep.02,23	Sep.01,24
Bilog Antenna	ETS-LINDGRE N	3143B	00161965	Feb. 18,23	Feb. 17,24
Horn Antenna	ETS-LINDGRE N	3117	00168692	Feb. 18,23	Feb. 17,24
Horn Antenna (18GHz-40GHz)	N/A	QWH-SL-18-40-K- SG/QMS-00361	15433	Sep.03, 23	Sep.02, 24
Radio Communication Analyzer	ANRITSU	MT8820C	6201465426	Feb. 14,23	Feb. 13,24
Signal Pre-Amplifier	EMSI	EMC 9135	980249	May. 06,23	May. 05,24
Signal Pre-Amplifier	EMSI	EMC 012645B	980257	May.10,23	May.09,24
Signal Pre-Amplifier	EMSI	EMC 184045B	980259	Feb. 17,23	Feb.16,24
3m Semi-anechoic Chamber	ETS-LINDGRE N	9m*6m*6m	Euroshieldpn- CT0001143-121 6	May. 22, 23	May. 21,26
Test Software	E3	V 9.160323	N/A	N/A	N/A
Test Software	JS1120	3.1.36	N/A	N/A	N/A
10dB Attenuator	JFW/USA	50HF-010-SMA	50HF-010-SMA	May. 06,23	May. 05,24
Power Meter	Anritsu	ML2495A	1506002	Feb. 14,23	Feb. 13,24
Power Sensor	Anritsu	MA2411B	1339352	Feb. 14,23	Feb. 13,24
Temperature Chamber	ESPEC	SH-242	93000855	May. 06,23	May. 05,24
MXG Analog Microvave Signal Generator	KEYSIGHT	N5183A	MY50143024	Feb. 14,23	Feb. 13,24
Base station R&S CMW500	Rohde&Schwa rz	CMW500	153085	May.10,23	May.09,24
DC Source	Kikusui/JP	PMX18-5A	N/A	Aug. 11,23	Aug. 10,24

- NOTE:**
1. The calibration interval of the above test instruments is 12 or 36 months and the calibrations are traceable to CEPREI/CHINA, GRGT/CHINA and NIM/CHINA.
 2. The test was performed in 3m Semi-anechoic Chamber and RF Oven Room.
 3. The horn antenna is used only for the measurement of emission frequency above 1GHz if tested.
 4. The IC Company Number is 21771; The CAB Identifier No. is CN0007.



2 GENERAL INFORMATION

2.1 GENERAL DESCRIPTION OF EUT

PRODUCT	Montior One DE	
BRAND NAME	Particle	
MODEL NAME	MON404-DE	
NOMINAL VOLTAGE	24Vdc(adapter or host equipment) 3.7Vdc (Li-ion, battery)	
MODULATION TYPE	GSM/EDGE	GMSK, 8PSK
	LTE CAT-M1	QPSK, 16QAM
FREQUENCY RANGE	GSM/EDGE	824.2MHz ~ 848.8MHz
	LTE Band 5 (Channel Bandwidth: 1.4MHz)	824.7MHz ~ 848.3MHz
	LTE Band 5 (Channel Bandwidth: 3MHz)	825.5MHz ~ 847.5MHz
	LTE Band 5 (Channel Bandwidth: 5MHz)	826.5MHz ~ 846.5MHz
	LTE Band 5 (Channel Bandwidth: 10MHz)	829MHz ~ 844MHz
MAX. ERP POWER	GSM	1527.57mW
	EDGE	376.7mW
	LTE Band 5 (Channel Bandwidth: 1.4MHz)	211.35mW
	LTE Band 5 (Channel Bandwidth: 3MHz)	208.45mW
	LTE Band 5 (Channel Bandwidth: 5MHz)	210.86mW
	LTE Band 5 (Channel Bandwidth: 10MHz)	213.8mW
EMISSION DESIGNATOR GOGN	GSM	246KGXW
	EDGE	249KG7W
	LTE Band 5 (Channel Bandwidth: 1.4MHz)	QPSK: 1M11G7D
		16QAM: 947KW7D
		64QAM: /
	LTE Band 5 (Channel Bandwidth: 3MHz)	QPSK: 1M16G7D
		16QAM: 983KW7D
64QAM: /		



	LTE Band 5 (Channel Bandwidth: 5MHz)	QPSK: 1M15G7D
		16QAM: 1M01W7D
		64QAM: /
	LTE Band 5 (Channel Bandwidth: 10MHz)	QPSK: 1M20G7D
		16QAM: 1M05W7D
		64QAM: /
ANTENNA TYPE	Fixed External Antenna with 1.7dBi gain for GSM850/ LTE B5	
HW VERSION	v1.2.0	
SW VERSION	v4.0.2	
IMEI	Refer to user's manual	
I/O PORTS	Cable 1: non-shielded cable, with w/o ferrite core, 1.5 meter Cable 2: non-shielded cable, with w/o ferrite core, 1.5 meter	
CABLE SUPPLIED	-20~60 °C	
EXTREME TEMPERATURE	3.6V - 4.2V	
EXTREME VOLTAGE	v1.2.0	

NOTE:

- For a more detailed features description, please refer to the manufacturer's specifications or the user's manual.
- The EUT incorporates a SISO function. Physically, the EUT provides one completed transmitter and one receiver.

MODULATION MODE	TX FUNCTION
GSM/GPRS/EDGE	1TX/1RX
LTE	1TX/1RX

- For the test results, the EUT had been tested with all conditions. But only the worst case was shown in test report.

List of Accessory:

ACCESSORIES	BRAND	MANUFACTURER	MODEL	SPECIFICATION
Battery	Guangdong Zhaoneng	Guangdong Zhaoneng	ZN18650-4P	Capacity: 3.7Vdc, 12200mAh
AC Adapter	TRI-MAG	TRI-MAG LLC	L6R30-240	I/P: 100-240Vac, 0.8A, O/P: 24Vdc, 1.25A
Cable 1	KAWEEI	KAWEEI technology	CBH-M12M-04 -1500	Signal Line, 1.5meter
Cable 2	KAWEEI	KAWEEI technology	115-00014 CBH-M12M-08 -1500	Signal Line, 1.5meter



2.2 CONFIGURATION OF SYSTEM UNDER TEST

FOR RADIATION EMISSION

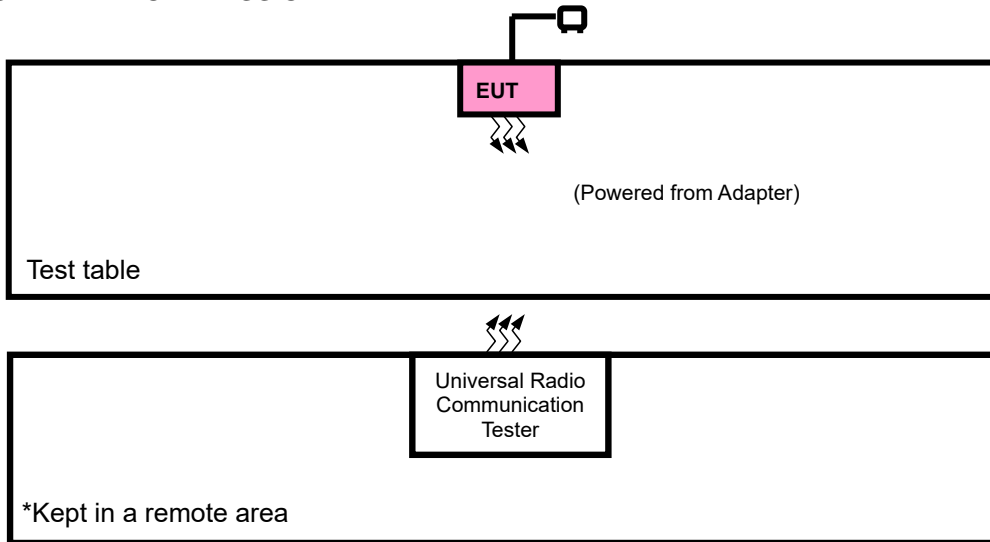



2.3 DESCRIPTION OF SUPPORT UNITS

The EUT has been tested as an independent unit together with other necessary accessories or support units. The following support units or accessories were used to form a representative test configuration during the tests.

NO.	PRODUCT	BRAND	MODEL NO.	SERIAL NO.	FCC ID
1	Adapter	Jingsai	CLS-050200	NA	N/A

NO.	SIGNAL CABLE DESCRIPTION OF THE ABOVE SUPPORT UNITS
1	N/A

2.4 TEST ITEM AND TEST CONFIGURATION

Pre-Scan has been conducted to determine the worst-case mode from all possible combinations between available modulations, data rates, XYZ axis and antenna ports. The worst case in ERP and radiated emission was found when positioned on X-plane for LTE. Following channel(s) was (were) selected for the final test as listed below:

EUT CONFIGURE MODE	DESCRIPTION
A	EUT + Adapter with GSM or LTE link



GSM MODE

EUT CONFIGURE MODE	TEST ITEM	AVAILABLE CHANNEL	TESTED CHANNEL	MODE
A	ERP	128 to 251	128, 190, 251	GSM,EDGE
A	RADIATED EMISSION	128 to 251	128, 190, 251	GSM,EDGE

LTE BAND 5 MODE

EUT CONFIGURE MODE	TEST ITEM	Available Channel	Tested Channel	Channel bandwidth	modulation	mode
A	ERP	20407 to 20643	20407, 20525, 20643	1.4MHz	QPSK,16QAM	1 RB / 0 RB Offset
		20415 to 20635	20415, 20525, 20635	3MHz	QPSK,16QAM	1 RB / 0 RB Offset
		20425 to 20625	20425, 20525, 20625	5MHz	QPSK,16QAM	1 RB / 0 RB Offset
		20450 to 20600	20450, 20525, 20600	10MHz	QPSK,16QAM	1 RB / 0 RB Offset
A	RADIATED EMISSION	20407 to 20643	20525	1.4MHz	QPSK	1 RB / 0 RB Offset
		20415 to 20635	20415, 20525, 20635	3MHz	QPSK	1 RB / 0 RB Offset
		20425 to 20625	20525	5MHz	QPSK	1 RB / 0 RB Offset
		20450 to 20600	20525	10MHz	QPSK	1 RB / 0 RB Offset

Note: 1.This device was tested under all bandwidths, RB configurations and modulations. The worst case was found in QPSK modulation.



BUREAU
VERITAS

Test Report No.: W7L-P23100004RI02

TEST CONDITION:

TEST ITEM	ENVIRONMENTAL CONDITIONS	INPUT POWER	TESTED BY
ERP	23deg. C, 70%RH	DC 24V By Adapter	Jace Hu
RADIATED EMISSION	23deg. C, 70%RH	DC 24V By Adapter	James Fu



2.5 EUT OPERATING CONDITIONS

The EUT makes a call to the communication simulator. The communication simulator station system controlled a EUT to export maximum output power under transmission mode and specific channel frequency

2.6 GENERAL DESCRIPTION OF APPLIED STANDARDS

The EUT is a RF product. According to the specifications of the manufacturer, it must comply with the requirements of the following standards:

Canada RSS-132, Issue 4, January 31, 2023

Canada RSS-Gen, Issue 5, March 2019 Amendment 1

ANSI C63.26 - 2015

NOTE: All test items have been performed and recorded as per the above standards.

2.7 TRANSMIT ANTENNA

The applicant for equipment certification shall provide a list of all antenna types that may be used with the transmitter, where applicable (i.e. for transmitters with detachable antenna), indicating the maximum permissible antenna gain (in dBi) and the required impedance for each antenna. The test report shall demonstrate the compliance of the transmitter with the limit for maximum equivalent isotropically radiated power (e.i.r.p.) specified in the applicable RSS, when the transmitter is equipped with any antenna type, selected from this list.

Antenna Type	Fixed External antenna
Antenna Gain	1.7dBi for GSM850/ LTE Band5
Impedance	50 Ω



3 TEST TYPES AND RESULTS

3.1 OUTPUT POWER MEASUREMENT

3.1.1 LIMITS OF OUTPUT POWER MEASUREMENT

Portable station are limited to 3 watts E.R.P.

3.1.2 TEST PROCEDURES

ERP MEASUREMENT:

Per KDB 971168 D01 Power Meas License Digital Systems v03r01 or subclause 5.2.5.5 of ANSI C63.26-2015, the relevant equation for determining the ERP from the conducted RF output power measured using the guidance provided above is:

$$ERP = P_{Meas} + G_T - L_C$$

Where:

ERP = effective radiated power or equivalent isotropically radiated power, respectively

(expressed in the same units as P_{Meas} , typically dBW or dBm);

P_{Meas} = measured transmitter output power or PSD, in dBm or dBW;

G_T = gain of the transmitting antenna, in dBd (ERP);

L_C = signal attenuation in the connecting cable between the transmitter and antenna, in dB.

CONDUCTED POWER MEASUREMENT:

The EUT was set up for the maximum power with WCDMA link data modulation and link up with simulator. Set the EUT to transmit under low, middle and high channel and record the power level shown on simulator.



3.1.3 TEST SETUP

For the actual test configuration, please refer to the attached file (Test Setup Photo).

CONDUCTED POWER MEASUREMENT:

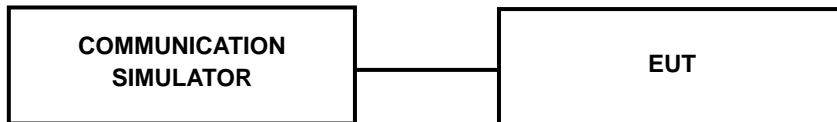

3.1.4 TEST RESULTS

CONDUCTED OUTPUT POWER (dBm)

Band	GSM850		
Channel	128	190	251
Frequency (MHz)	824.2	836.6	848.8
GPRS (GMSK, 1Tx-slot)	32.29	32.25	32.16
GPRS (GMSK, 2Tx-slot)	32.21	32.19	32.09
GPRS (GMSK, 3Tx-slot)	31.34	30.85	30.84
GPRS (GMSK, 4Tx-slot)	29.64	29.73	29.37
EDGE (8PSK, 1Tx-slot)	26.01	26.21	26.04
EDGE (8PSK, 2Tx-slot)	25.84	26.06	25.89
EDGE (8PSK, 3Tx-slot)	25.64	25.89	25.65
EDGE (8PSK, 4Tx-slot)	25.45	25.78	25.41



LTE Band 5

Band/BW	Modulation	RB Size	RB Offset	Low CH 20407	Mid CH 20525	High CH 20643
				Frequency 824.7 MHz	Frequency 836.5 MHz	Frequency 848.3 MHz
5/ 1.4	QPSK	1	0	23.54	23.40	23.70
		1	5	23.52	23.46	23.46
		3	0	23.54	23.41	23.57
		3	3	23.53	23.32	23.52
		6	0	23.57	23.52	23.59
	16QAM	1	0	23.48	23.59	23.61
		1	5	23.55	23.32	23.59
		3	0	23.59	23.46	23.44
		3	3	23.51	23.57	23.59
		5	0	23.54	23.40	23.54

Band/BW	Modulation	RB Size	RB Offset	Low CH 20415	Mid CH 20525	High CH 20635
				Frequency 825.5 MHz	Frequency 836.5 MHz	Frequency 847.5 MHz
5/ 3	QPSK	1	0	23.64	23.50	23.63
		1	5	23.44	23.39	23.47
		3	0	23.49	23.47	23.44
		3	3	23.61	23.42	23.60
		6	0	23.59	23.42	23.45
	16QAM	1	0	23.57	23.50	23.53
		1	5	23.55	23.40	23.48
		3	0	23.51	23.45	23.53
		3	3	23.60	23.60	23.52
		5	0	23.58	23.44	23.58



Band/BW	Modulation	RB Size	RB Offset	Low CH 20425	Mid CH 20525	High CH 20625
				Frequency 826.5 MHz	Frequency 836.5 MHz	Frequency 846.5 MHz
5/ 5	QPSK	1	0	23.67	23.44	23.69
		1	5	23.49	23.44	23.52
		3	0	23.54	23.39	23.46
		3	3	23.58	23.45	23.55
		6	0	23.55	23.55	23.52
	16QAM	1	0	23.52	23.46	23.57
		1	5	23.50	23.30	23.61
		3	0	23.54	23.41	23.48
		3	3	23.59	23.52	23.63
		5	0	23.50	23.53	23.55

Band/BW	Modulation	RB Size	RB Offset	Low CH 20450	Mid CH 20525	High CH 20600
				Frequency 829 MHz	Frequency 836.5 MHz	Frequency 844 MHz
5/ 10	QPSK	1	0	23.68	23.54	23.75
		1	5	23.55	23.49	23.54
		3	0	23.59	23.50	23.59
		3	3	23.62	23.46	23.61
		6	0	23.66	23.57	23.60
	16QAM	1	0	23.63	23.60	23.66
		1	5	23.64	23.42	23.62
		3	0	23.66	23.48	23.59
		3	3	23.64	23.61	23.66
		5	0	23.62	23.55	23.67



ERP POWER (dBm)

GSM

Channel	Frequency (MHz)	Conducted Power (dBm)	G _{T-Lc} (dB)	ERP (dBm)	ERP (mW)	Limit (W)
128	824.2	32.29	1.7	31.84	1527.57	3
190	836.6	32.25	1.7	31.8	1513.56	3
251	848.8	32.16	1.7	31.71	1482.52	3

EDGE

Channel	Frequency (MHz)	Conducted Power (dBm)	G _{T-Lc} (dB)	ERP (dBm)	ERP (mW)	Limit (W)
128	824.2	26.01	1.7	25.56	359.75	3
190	836.6	26.21	1.7	25.76	376.7	3
251	848.8	26.04	1.7	25.59	362.24	3

LTE BAND 5

CHANNEL BANDWIDTH: 1.4MHz QPSK

Channel	Frequency (MHz)	Conducted Power (dBm)	G _{T-Lc} (dB)	ERP (dBm)	ERP (mW)	Limit (W)
20407	824.7	23.57	1.7	23.12	205.12	3
20525	836.5	23.52	1.7	23.07	202.77	3
20643	848.3	23.7	1.7	23.25	211.35	3

CHANNEL BANDWIDTH: 1.4MHz 16QAM

Channel	Frequency (MHz)	Conducted Power (dBm)	G _{T-Lc} (dB)	ERP (dBm)	ERP (mW)	Limit (W)
20407	824.7	23.59	1.7	23.14	206.06	3
20525	836.5	23.59	1.7	23.14	206.06	3
20643	848.3	23.61	1.7	23.16	207.01	3



CHANNEL BANDWIDTH: 3MHz QPSK

Channel	Frequency (MHz)	Conducted Power (dBm)	G _T -L _c (dB)	ERP (dBm)	ERP (mW)	Limit (W)
20415	825.5	23.64	1.7	23.19	208.45	3
20525	836.5	23.5	1.7	23.05	201.84	3
20635	847.5	23.63	1.7	23.18	207.97	3

CHANNEL BANDWIDTH: 3MHz 16QAM

Channel	Frequency (MHz)	Conducted Power (dBm)	G _T -L _c (dB)	ERP (dBm)	ERP (mW)	Limit (W)
20415	825.5	23.6	1.7	23.15	206.54	3
20525	836.5	23.6	1.7	23.15	206.54	3
20635	847.5	23.58	1.7	23.13	205.59	3

CHANNEL BANDWIDTH: 5MHz QPSK

Channel	Frequency (MHz)	Conducted Power (dBm)	G _T -L _c (dB)	ERP (dBm)	ERP (mW)	Limit (W)
20425	826.5	23.67	1.7	23.22	209.89	3
20525	836.5	23.55	1.7	23.1	204.17	3
20625	846.5	23.69	1.7	23.24	210.86	3

CHANNEL BANDWIDTH: 5MHz 16QAM

Channel	Frequency (MHz)	Conducted Power (dBm)	G _T -L _c (dB)	ERP (dBm)	ERP (mW)	Limit (W)
20425	826.5	23.59	1.7	23.14	206.06	3
20525	836.5	23.53	1.7	23.08	203.24	3
20625	846.5	23.63	1.7	23.18	207.97	3



CHANNEL BANDWIDTH: 10MHz QPSK

Channel	Frequency (MHz)	Conducted Power (dBm)	G _{T-Lc} (dB)	ERP (dBm)	ERP (mW)	Limit (W)
20450	829.0	23.68	1.7	23.23	210.38	3
20525	836.5	23.57	1.7	23.12	205.12	3
20600	844.0	23.75	1.7	23.3	213.8	3

CHANNEL BANDWIDTH: 10MHz 16QAM

Channel	Frequency (MHz)	Conducted Power (dBm)	G _{T-Lc} (dB)	ERP (dBm)	ERP (mW)	Limit (W)
20450	829.0	23.66	1.7	23.21	209.41	3
20525	836.5	23.61	1.7	23.16	207.01	3
20600	844.0	23.67	1.7	23.22	209.89	3



3.2 FREQUENCY STABILITY MEASUREMENT

3.2.1 LIMITS OF FREQUENCY STABILITY MEASUREMENT

1.5ppm is for base and fixed station. 2.5 ppm is for mobile station.

3.2.2 TEST PROCEDURE

- Device is placed at the oven room. The oven room could control the temperatures and humidity. Power warm up is at least 15 min and power applied should perform before recording frequency error.
- EUT is connected the external power supply to control the DC input power. The test voltage range is from minimum to maximum working voltage. Each step shall be record the frequency error rate.
- The temperature range step is 10 degrees in this test items. All temperature levels shall be hold the $\pm 0.5^{\circ}\text{C}$ during the measurement testing. The each temperature step shall be at least 0.5 hours, consider the EUT could be test under the stability condition.

NOTE: The frequency stability shall be sufficient to ensure that the occupied bandwidth stays within each of the sub-bands when tested at the temperature and supply voltage variations specified in RSS-Gen.

3.2.3 TEST SETUP

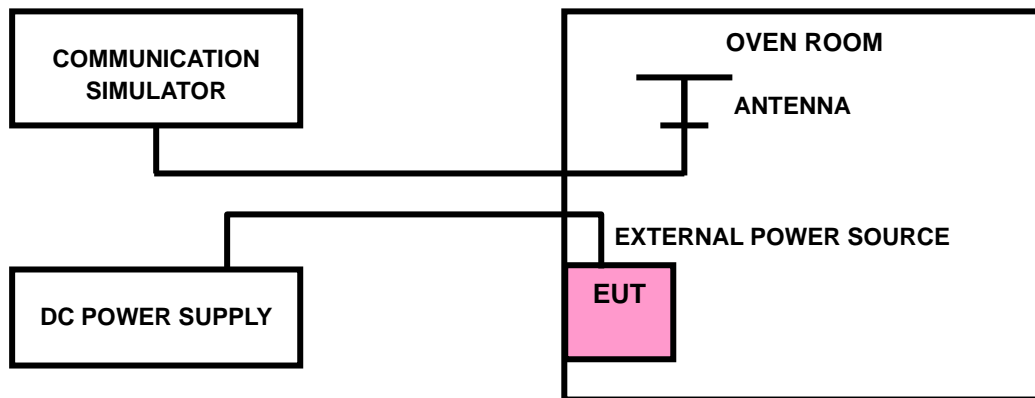



Test Report No.: W7L-P23100004RI02

3.2.4 TEST RESULTS

Please Refer to Module report R1811A0536-R7.



3.3 OCCUPIED BANDWIDTH MEASUREMENT

3.3.1 TEST PROCEDURES

The EUT makes a call to the communication simulator. All measurements were done at low, middle and high operational frequency range. The communication simulator station system controlled a EUT to export maximum output power under transmission mode and specific channel frequency. Use OBW measurement function of Spectrum analyzer to measure 99 % occupied bandwidth.

3.3.2 TEST SETUP

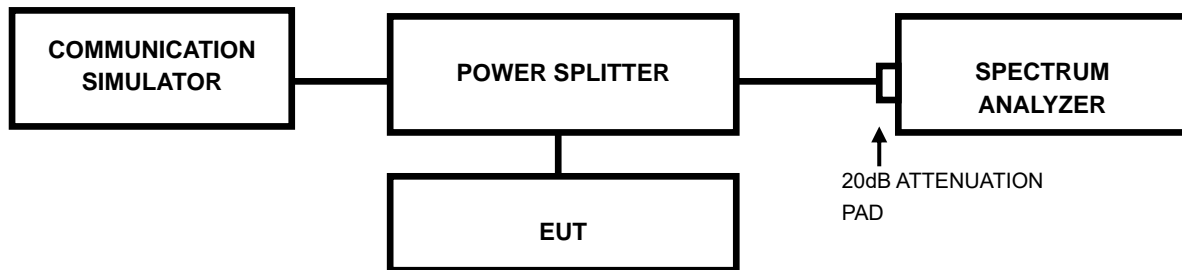



BUREAU
VERITAS

Test Report No.: W7L-P23100004RI02

3.3.3 TEST RESULTS

Please Refer to Module report R1811A0536-R7.



3.4 BAND EDGE MEASUREMENT

3.4.1 LIMITS OF BAND EDGE MEASUREMENT

Power of any emission outside of the authorized operating frequency ranges must be attenuated below the transmitting power (P) by a factor of at least $43 + 10 \log(P)$ dB. In the 1 MHz bands immediately outside and adjacent to the frequency block a resolution bandwidth of at least one percent of the emission bandwidth of the fundamental emission of the transmitter may be employed.

3.4.2 TEST SETUP

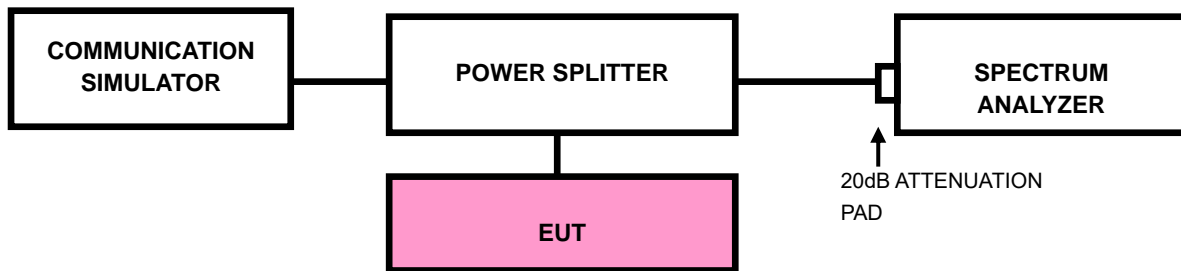



3.4.3 TEST PROCEDURES

- a) All measurements were done at low and high operational frequency range
- b) Connect the transmitter to the spectrum analyzer via coaxial cable while ensuring proper impedance matching.
- c) Tune the analyzer to the nominal center frequency of the emission bandwidth (EBW)
- d) .Set the resolution bandwidth (RBW) $\geq 1\%$ EBW in the 1MHz band immediately outside and adjacent to the band edge.
- e) Beyond the 1MHz band from the band edge, RBW=1MHz was used.
- f) Set the video bandwidth (VBW) to $\geq 3 \times$ RBW.
- g) Select the average power (RMS) display detector.
- h) Set the number of measurement points to ≥ 1001 .
- i) Use auto-coupled sweep time.
- j) Perform the measurement over an interval of time when the transmission is continuous and at its maximum power level.
- k) The RF fundamental frequency should be excluded against the limit line in the operating frequency band and use RBW is 10KHz or 100KHz.
- l) Record the max trace plot into the test report.



BUREAU
VERITAS

Test Report No.: W7L-P23100004RI02

3.4.4 TEST RESULTS

Please Refer to Module report R1811A0536-R7.



3.5 CONDUCTED SPURIOUS EMISSIONS

3.5.1 LIMITS OF CONDUCTED SPURIOUS EMISSIONS MEASUREMENT

The power of any emission outside of the authorized operating frequency ranges must be attenuated below the transmitting power (P) by a factor of at least $43 + 10 \log(P)$ dB. The emission limit equal to -13dBm .

3.5.2 TEST PROCEDURE

- a. The EUT makes a phone call to the communication simulator. All measurements were done at low, middle and high operational frequency range.
- b. Measuring frequency range is from 9kHz up to a frequency including its 10th harmonic. 10dB attenuation pad is connected with spectrum. RBW=1MHz and VBW=3MHz is used for conducted emission measurement.

3.5.3 TEST SETUP

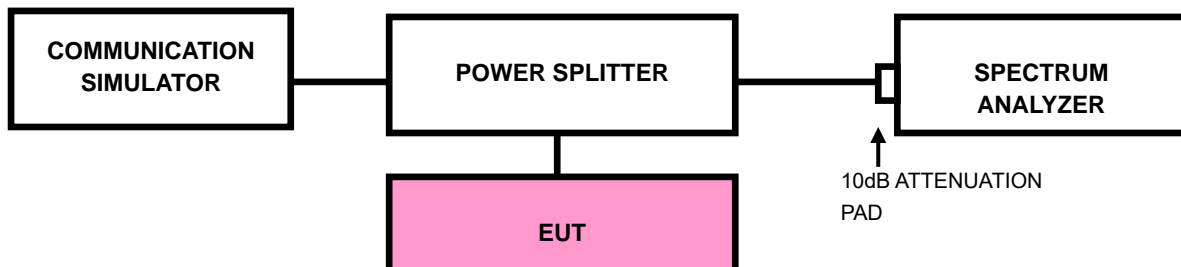



**BUREAU
VERITAS**

Test Report No.: W7L-P23100004RI02

3.5.4 TEST RESULTS

NOTE : The 9K~30MHz amplitude of spurious emissions attenuated more than 20 dB below the permissible value is not required in the report.

Please Refer to Module report R1811A0536-R7.



3.6 RADIATED EMISSION MEASUREMENT

3.6.1 LIMITS OF RADIATED EMISSION MEASUREMENT

The power of any emission outside of the authorized operating frequency ranges must be attenuated below the transmitting power (P) by a factor of at least $43 + 10 \log(P)$ dB. The emission limit equal to -13dBm .

3.6.2 TEST PROCEDURES

- a. Substitution method is used for E.I.R.P measurement. In the semi-anechoic chamber, EUT placed on the 0.8m/1.5m height of Turn Table, rotated the table around 360 degrees to search the maximum radiation power and receiver antenna shall be rotated vertical and horizontal polarization and moved height from 1m to 4m to find the maximum polar radiated power. The “Read Value” is the spectrum reading the maximum power value.
- b. The substitution horn antenna is substituted for EUT at the same position and signals generator export the CW signal to the substitution antenna via a TX cable. Rotated the Turn Table and moved receiving antenna to find the maximum radiation power. Adjust output power level of S.G to get a Value of spectrum reading equal to “Read Value” of step a. Record the power level of S.G
- c. $\text{ERP} = \text{Output power level of S.G} - \text{TX cable loss} + \text{Antenna gain of substitution horn}$.
- d. E.R.P power can be calculated form E.I.R.P power by subtracting the gain of dipole, $\text{E.R.P power} = \text{E.I.P.R power} - 2.15\text{dBi}$.

NOTE: The resolution bandwidth and video bandwidth of test receiver/spectrum analyzer is 1MHz/3MHz.

3.6.3 DEVIATION FROM TEST STANDARD

No deviation



3.6.4 TEST SETUP

< Frequency Range below 30MHz >

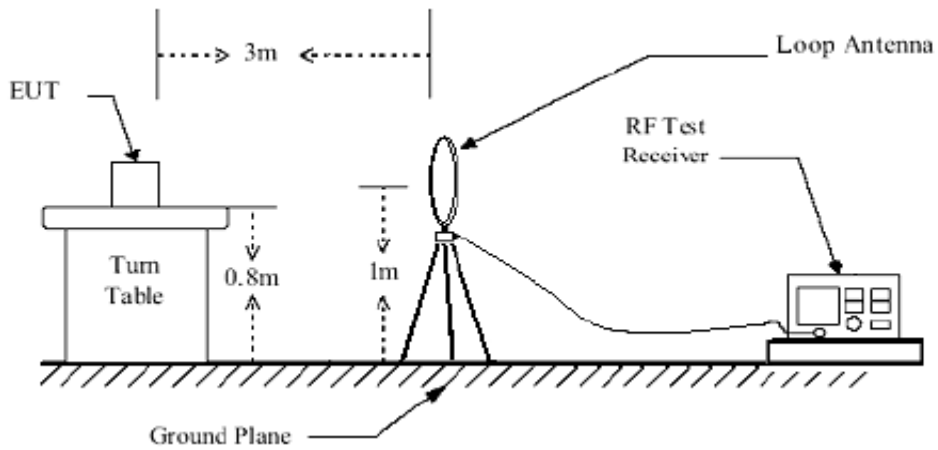

< Frequency Range 30MHz~1GHz >

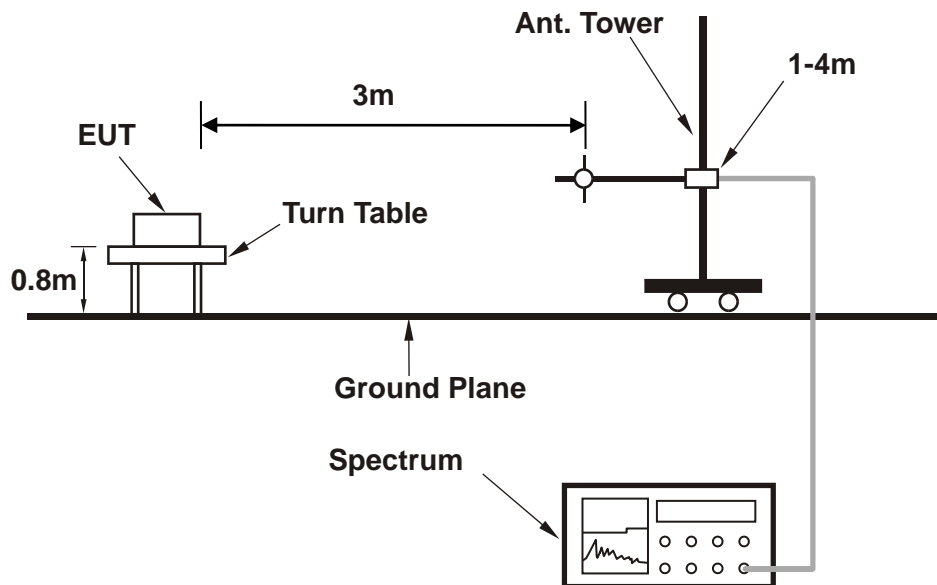



< Frequency Range above 1GHz >

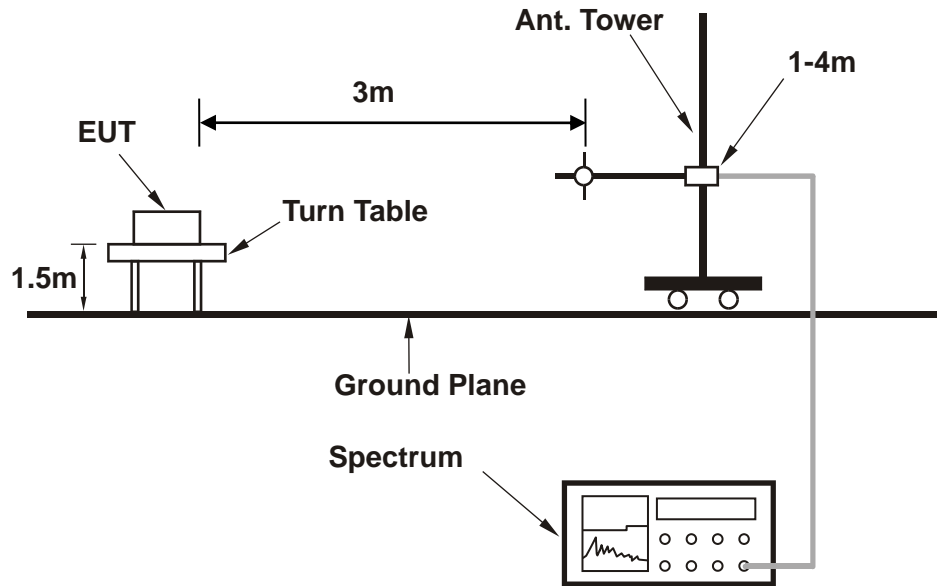

For the actual test configuration, please refer to the attached file (Test Setup Photo).



3.6.5 TEST RESULTS

NOTE : The 9K~30MHz amplitude of spurious emissions attenuated more than 20 dB below the permissible value is not required in the report.

BELOW 1GHz WORST-CASE DATA

30 MHz – 1GHz data:

EDGE 850:

CHANNEL BANDWIDTH: 128 ~ 251

MODE	TX channel 190	FREQUENCY RANGE	Below 1000MHz
ENVIRONMENTAL CONDITIONS	23deg. C, 70%RH	INPUT POWER	AC 120V/60HZ
TESTED BY	Jace Hu		
ANTENNA POLARITY & TEST DISTANCE: HORIZONTAL AT 3 M			

No.	Frequency MHz	Factor dB	Reading dBm	Emission dBm	Limit dBm	Margin dB	Tower / Table cm deg
1	31.55	-0.58	-66.03	-66.61	-13.00	-53.61	100 0
2	62.64	-12.61	-52.01	-64.62	-13.00	-51.62	100 0
3	90.62	-12.50	-51.34	-63.84	-13.00	-50.84	100 0
4	174.57	-8.64	-55.93	-64.57	-13.00	-51.57	100 0
5	239.86	-8.04	-62.67	-70.71	-13.00	-57.71	100 0
6	370.43	-4.97	-62.68	-67.65	-13.00	-54.65	100 0

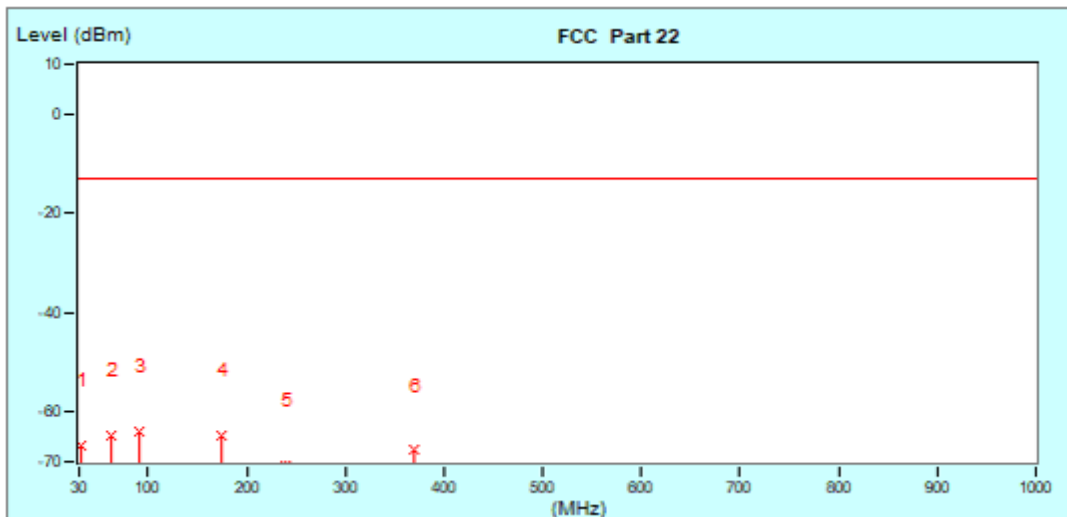



MODE	TX channel 190	FREQUENCY RANGE	Below 1000MHz
ENVIRONMENTAL CONDITIONS	23deg. C, 70%RH	INPUT POWER	AC 120V/60HZ
TESTED BY	Jace Hu		
ANTENNA POLARITY & TEST DISTANCE: VERTICAL AT 3 M			

No.	Frequency MHz	Factor dB	Reading dBm	Emission dBm	Limit dBm	Margin dB	Tower / Table cm deg	
1	30.00	0.60	-43.83	-43.23	-13.00	-30.23	100	0
2	43.99	-9.18	-40.34	-49.52	-13.00	-36.52	100	0
3	101.51	-9.78	-40.84	-50.62	-13.00	-37.62	100	0
4	115.50	-7.14	-43.27	-50.41	-13.00	-37.41	100	0
5	162.13	-8.14	-53.41	-61.55	-13.00	-48.55	100	0
6	216.54	-7.52	-51.20	-58.72	-13.00	-45.72	100	0

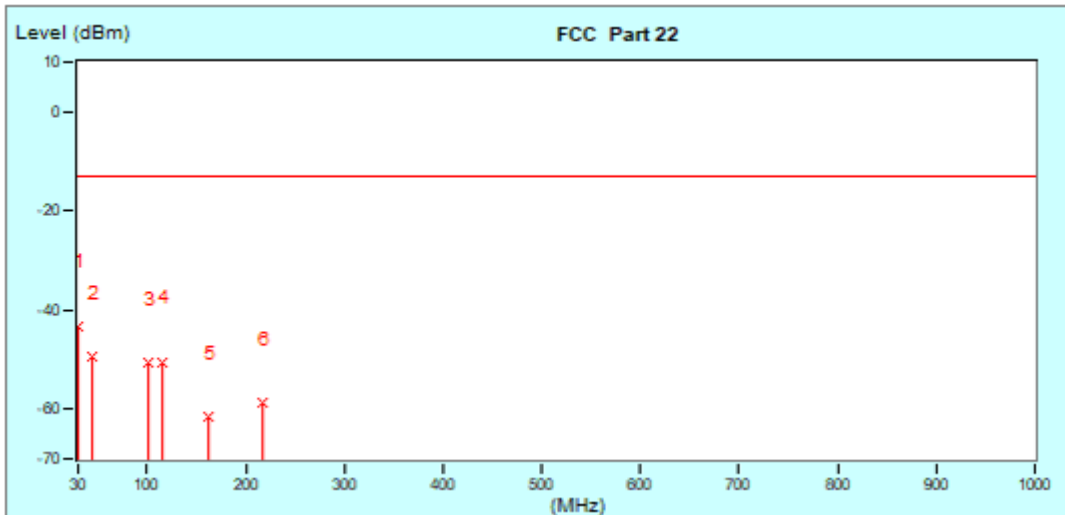



ABOVE 1GHz DATA

Note: For higher frequency, the emission is too low to be detected.

GSM 850

CH 128:

MODE	TX channel 128	FREQUENCY RANGE	Above 1000MHz
ENVIRONMENTAL CONDITIONS	23deg. C, 70%RH	INPUT POWER	AC 120V/60HZ
TESTED BY	Jace Hu		
ANTENNA POLARITY & TEST DISTANCE: HORIZONTAL AT 3 M			

No.	Frequency MHz	Factor dB	Reading dBm	Emission dBm	Limit dBm	Margin dB	Tower / Table cm deg	
* 1	1648.40 (PK)	-13.06	-23.04	-36.10	-13.00	-23.10	100	0
2	2472.60 (PK)	-10.82	-36.29	-47.11	-13.00	-34.11	100	0

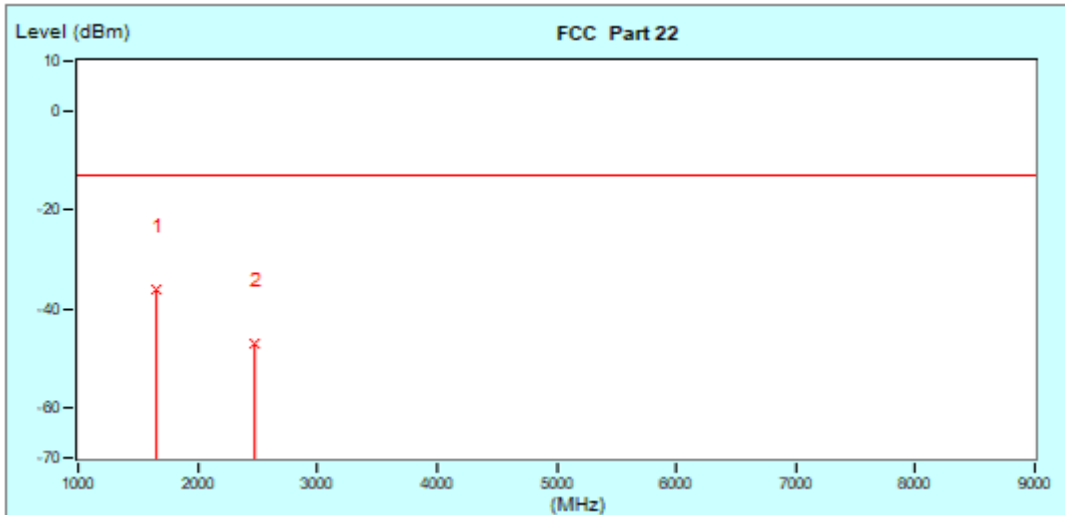



MODE	TX channel 128	FREQUENCY RANGE	Above 1000MHz
ENVIRONMENTAL CONDITIONS	23deg. C, 70%RH	INPUT POWER	AC 120V/60HZ
TESTED BY	Jace Hu		
ANTENNA POLARITY & TEST DISTANCE: VERTICAL AT 3 M			

No.	Frequency MHz	Factor dB	Reading dBm	Emission dBm	Limit dBm	Margin dB	Tower / Table cm deg	
1	1648.40 (PK)	-13.06	-23.35	-36.41	-13.00	-23.41	100	0
2	2472.60 (PK)	-10.82	-35.72	-46.54	-13.00	-33.54	100	0

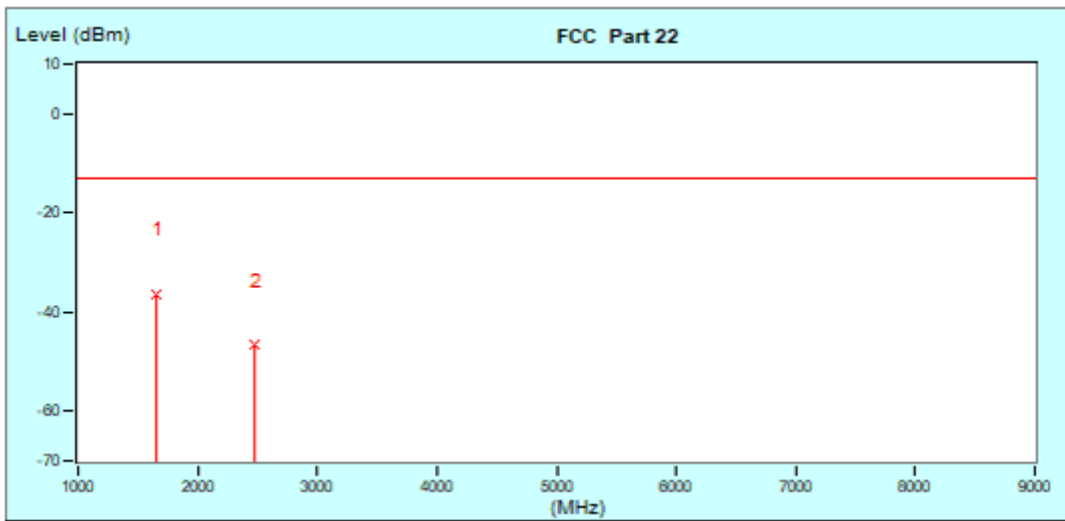



CH 190:

MODE	TX channel 190	FREQUENCY RANGE	Above 1000MHz
ENVIRONMENTAL CONDITIONS	23deg. C, 70%RH	INPUT POWER	AC 120V/60HZ
TESTED BY	Jace Hu		
ANTENNA POLARITY & TEST DISTANCE: HORIZONTAL AT 3 M			

No.	Frequency MHz	Factor dB	Reading dBm	Emission dBm	Limit dBm	Margin dB	Tower / Table cm deg	
* 1	1672.80 (PK)	-12.76	-24.68	-37.44	-13.00	-24.44	100	0
2	2509.20 (PK)	-10.94	-37.85	-48.79	-13.00	-35.79	100	0

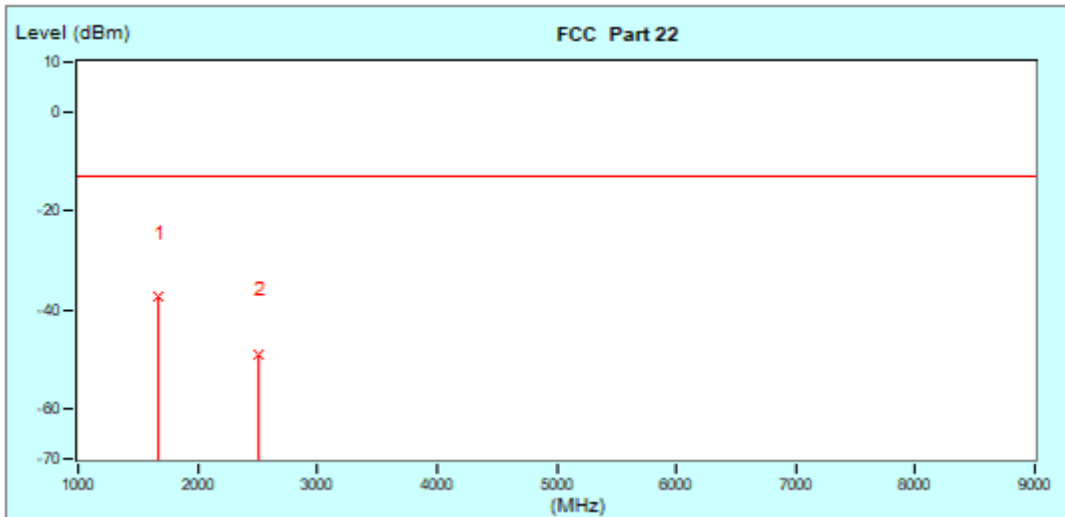



MODE	TX channel 190	FREQUENCY RANGE	Above 1000MHz
ENVIRONMENTAL CONDITIONS	23deg. C, 70%RH	INPUT POWER	AC 120V/60HZ
TESTED BY	Jace Hu		
ANTENNA POLARITY & TEST DISTANCE: VERTICAL AT 3 M			

No.	Frequency MHz	Factor dB	Reading dBm	Emission dBm	Limit dBm	Margin dB	Tower / Table cm deg	
1	1672.80 (PK)	-12.76	-16.02	-28.78	-13.00	-15.78	100	0
2	2509.50 (PK)	-10.93	-27.66	-38.59	-13.00	-25.59	100	0

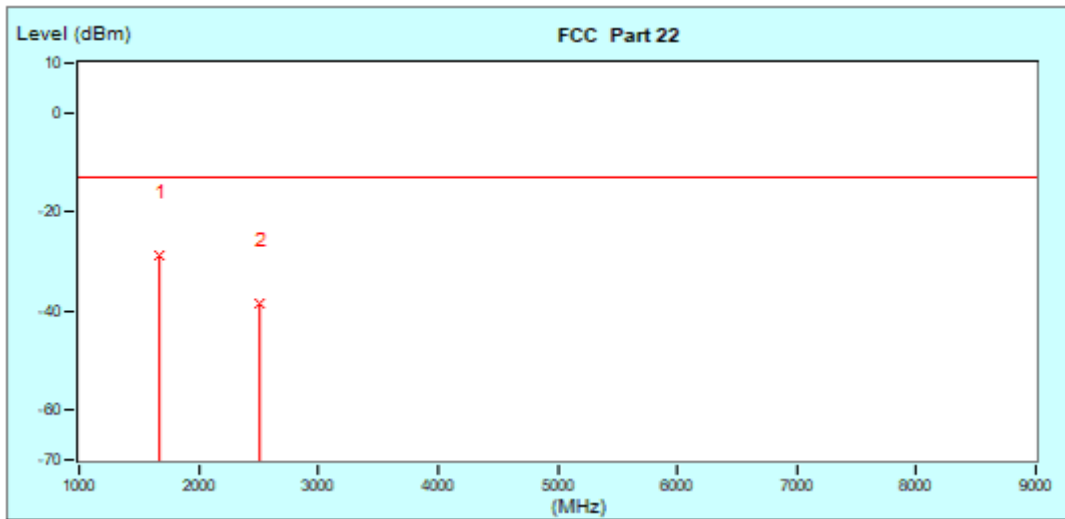



CH 251:

MODE	TX channel 251	FREQUENCY RANGE	Above 1000MHz
ENVIRONMENTAL CONDITIONS	23deg. C, 70%RH	INPUT POWER	AC 120V/60HZ
TESTED BY	Jace Hu		
ANTENNA POLARITY & TEST DISTANCE: HORIZONTAL AT 3 M			

No.	Frequency MHz	Factor dB	Reading dBm	Emission dBm	Limit dBm	Margin dB	Tower / Table cm deg	
1	1697.60 (PK)	-12.46	-28.66	-41.12	-13.00	-28.12	100	0
2	2546.40 (PK)	-10.94	-37.98	-48.92	-13.00	-35.92	100	0

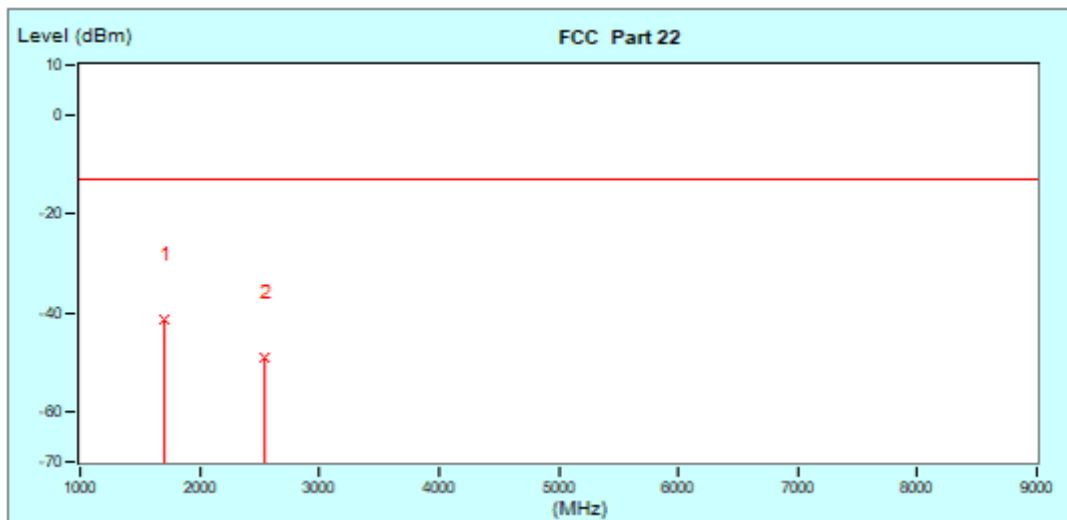



BUREAU VERITAS

Test Report No.: W7L-P23100004RI02

MODE	TX channel 251	FREQUENCY RANGE	Above 1000MHz
ENVIRONMENTAL CONDITIONS	23deg. C, 70%RH	INPUT POWER	AC 120V/60HZ
TESTED BY	Jace Hu		
ANTENNA POLARITY & TEST DISTANCE: VERTICAL AT 3 M			

No.	Frequency MHz	Factor dB	Reading dBm	Emission dBm	Limit dBm	Margin dB	Tower / Table cm deg	
1	1697.60 (PK)	-12.46	-27.25	-39.71	-13.00	-26.71	100	0
2	2546.40 (PK)	-10.94	-40.82	-51.76	-13.00	-38.76	100	0

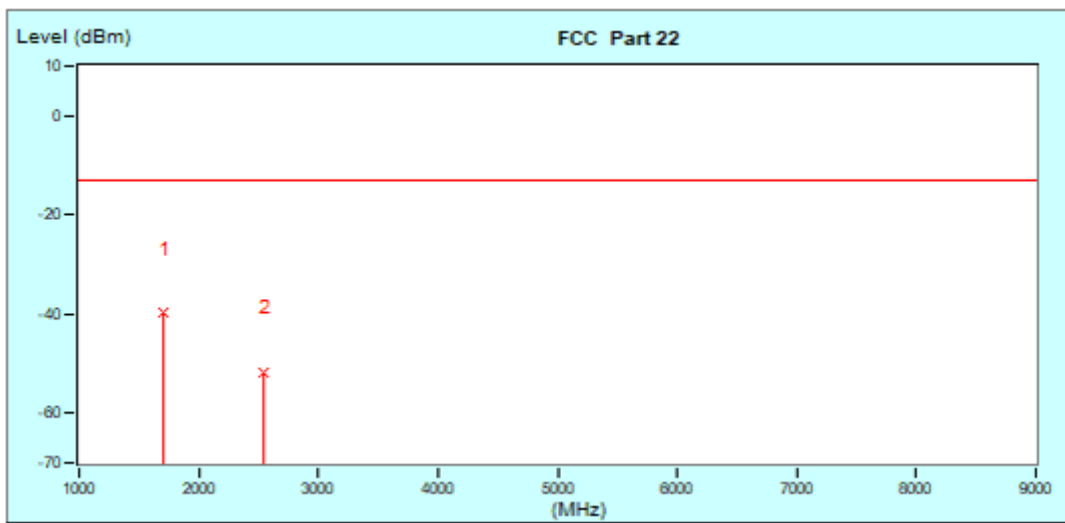



**BUREAU
VERITAS**

Test Report No.: W7L-P23100004RI02

EDGE 850:

CH 128:

MODE	TX channel 128	FREQUENCY RANGE	Above 1000MHz
ENVIRONMENTAL CONDITIONS	23deg. C, 70%RH	INPUT POWER	AC 120V/60HZ
TESTED BY	Jace Hu		
ANTENNA POLARITY & TEST DISTANCE: HORIZONTAL AT 3 M			

No.	Frequency MHz	Factor dB	Reading dBm	Emission dBm	Limit dBm	Margin dB	Tower / Table	
							cm	deg
* 1	1648.40 (PK)	-13.06	-14.15	-27.21	-13.00	-14.21	100	0
2	2472.60 (PK)	-10.82	-29.05	-39.87	-13.00	-26.87	100	0

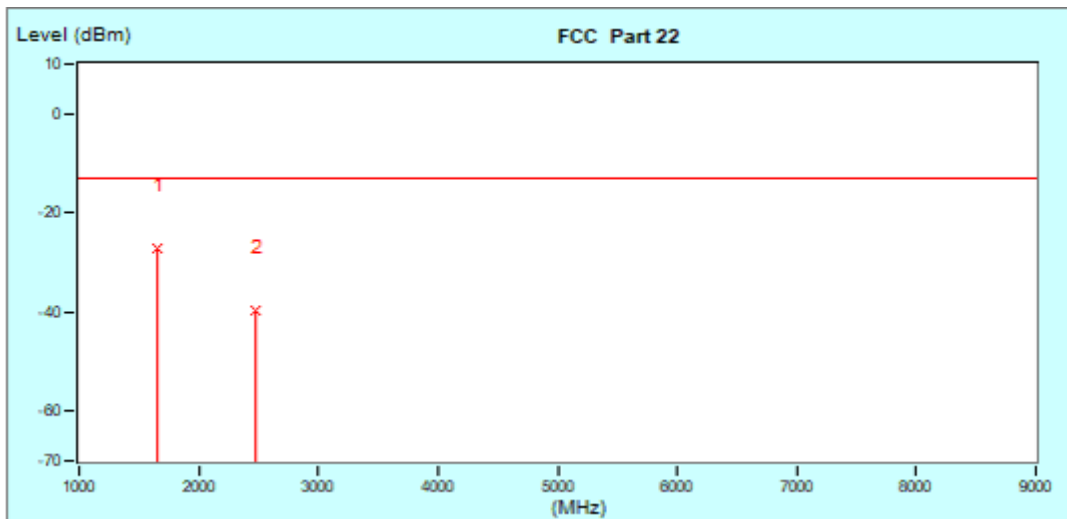



MODE	TX channel 128	FREQUENCY RANGE	Above 1000MHz
ENVIRONMENTAL CONDITIONS	23deg. C, 70%RH	INPUT POWER	AC 120V/60HZ
TESTED BY	Jace Hu		
ANTENNA POLARITY & TEST DISTANCE: VERTICAL AT 3 M			

No.	Frequency MHz	Factor dB	Reading dBm	Emission dBm	Limit dBm	Margin dB	Tower / Table cm deg	
1	1648.40 (PK)	-13.06	-17.36	-30.42	-13.00	-17.42	100	0
2	2472.60 (PK)	-10.82	-28.46	-39.28	-13.00	-26.28	100	0

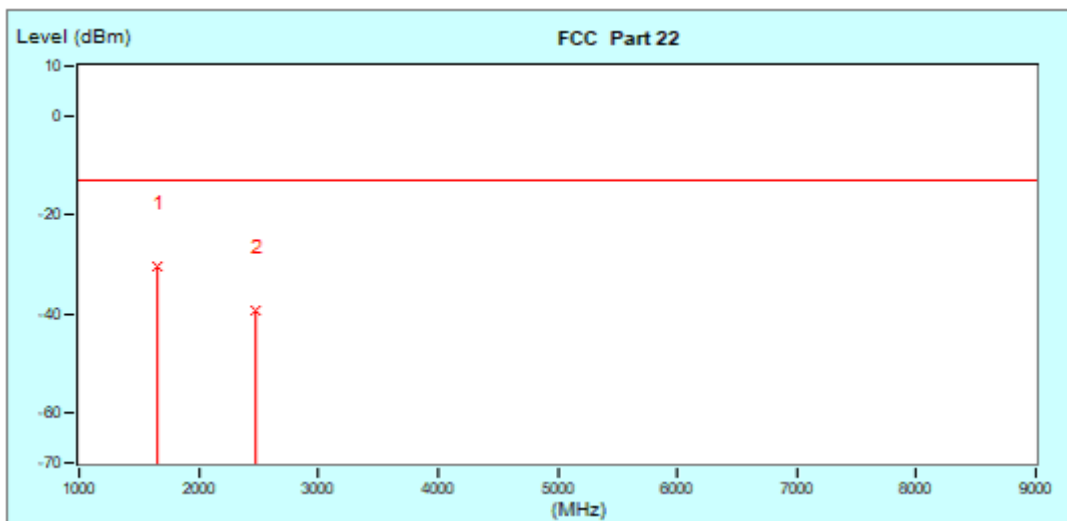



**BUREAU
VERITAS**

Test Report No.: W7L-P23100004RI02

CH 190:

MODE	TX channel 190	FREQUENCY RANGE	Above 1000MHz
ENVIRONMENTAL CONDITIONS	23deg. C, 70%RH	INPUT POWER	AC 120V/60HZ
TESTED BY	Jace Hu		
ANTENNA POLARITY & TEST DISTANCE: HORIZONTAL AT 3 M			

No.	Frequency MHz	Factor dB	Reading dBm	Emission dBm	Limit dBm	Margin dB	Tower / Table cm deg	
1	1672.80 (PK)	-12.76	-12.83	-25.59	-13.00	-12.59	100	0
2	2509.20 (PK)	-10.94	-23.69	-34.63	-13.00	-21.63	100	0

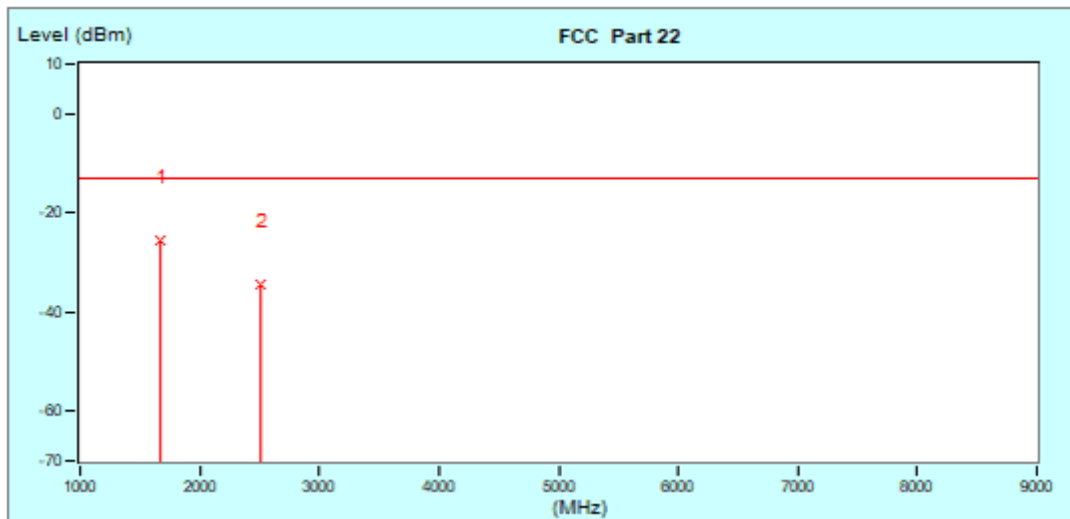



MODE	TX channel 190	FREQUENCY RANGE	Above 1000MHz
ENVIRONMENTAL CONDITIONS	23deg. C, 70%RH	INPUT POWER	AC 120V/60HZ
TESTED BY	Jace Hu		
ANTENNA POLARITY & TEST DISTANCE: VERTICAL AT 3 M			

No.	Frequency MHz	Factor dB	Reading dBm	Emission dBm	Limit dBm	Margin dB	Tower / Table cm deg	
1	1672.80 (PK)	-12.76	-16.30	-29.06	-13.00	-16.06	100	0
2	2509.20 (PK)	-10.94	-27.46	-38.40	-13.00	-25.40	100	0

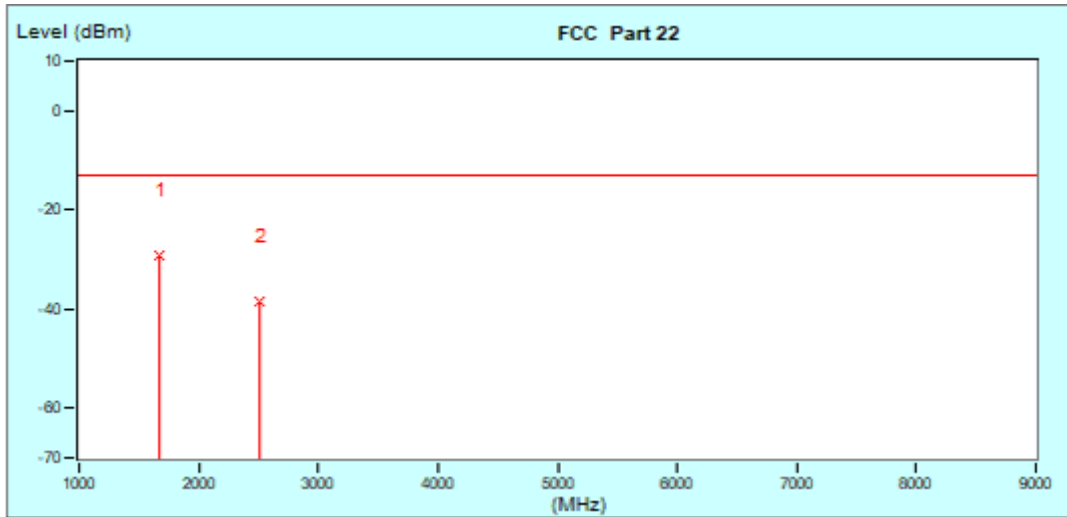



CH 251:

MODE	TX channel 251	FREQUENCY RANGE	Above 1000MHz
ENVIRONMENTAL CONDITIONS	23deg. C, 70%RH	INPUT POWER	AC 120V/60HZ
TESTED BY	Jace Hu		
ANTENNA POLARITY & TEST DISTANCE: HORIZONTAL AT 3 M			

No.	Frequency MHz	Factor dB	Reading dBm	Emission dBm	Limit dBm	Margin dB	Tower / Table cm deg	
* 1	1697.60 (PK)	-12.46	-13.95	-26.41	-13.00	-13.41	100	0
2	2546.40 (PK)	-10.94	-21.69	-32.63	-13.00	-19.63	100	0

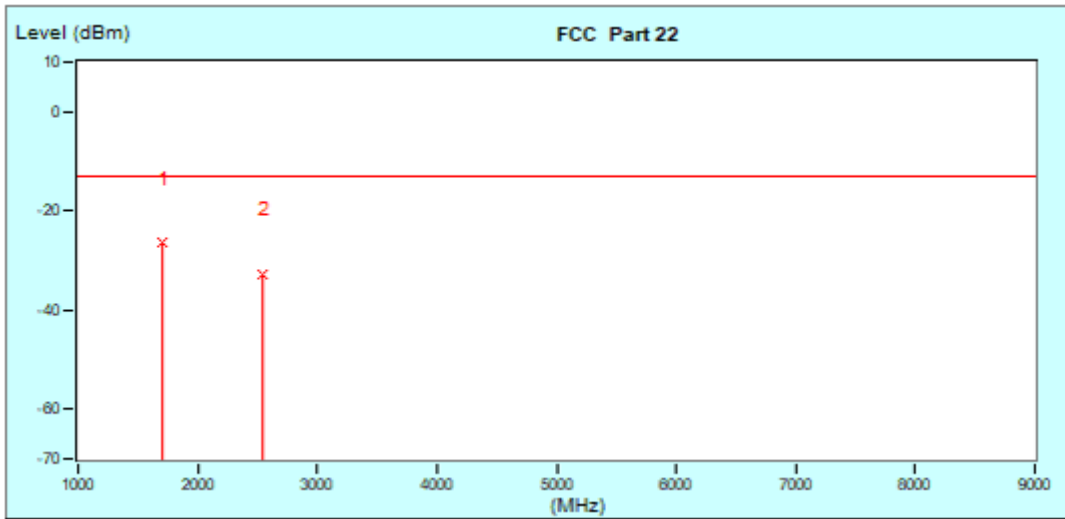



**BUREAU
VERITAS**

Test Report No.: W7L-P23100004RI02

MODE	TX channel 251	FREQUENCY RANGE	Above 1000MHz
ENVIRONMENTAL CONDITIONS	23deg. C, 70%RH	INPUT POWER	AC 120V/60HZ
TESTED BY	Jace Hu		
ANTENNA POLARITY & TEST DISTANCE: VERTICAL AT 3 M			

No.	Frequency MHz	Factor dB	Reading dBm	Emission dBm	Limit dBm	Margin dB	Tower / Table cm deg	
- 1	1697.60 (PK)	-12.46	-16.82	-29.28	-13.00	-16.28	100	0
2	2546.40 (PK)	-10.94	-24.78	-35.72	-13.00	-22.72	100	0

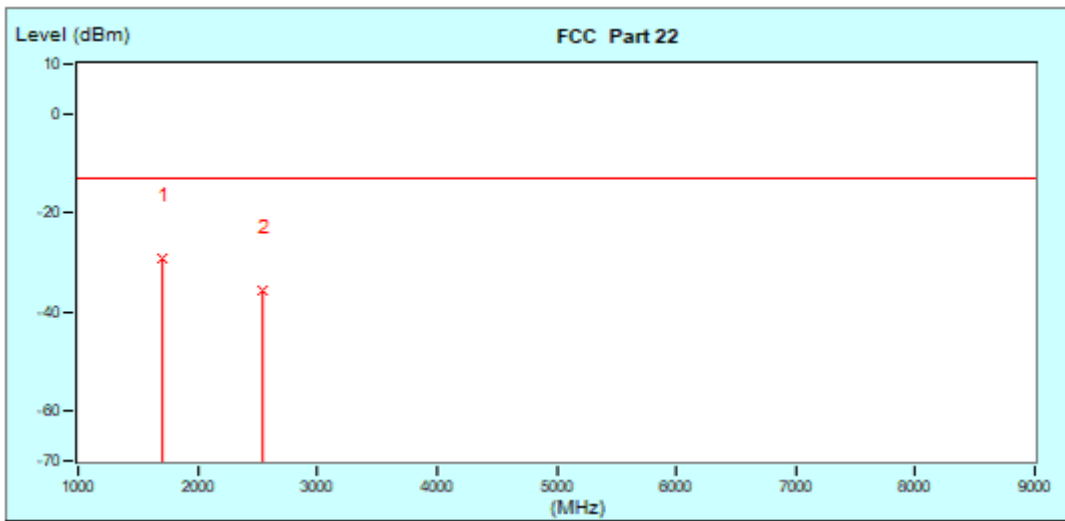



LTE Band 5

CHANNEL BANDWIDTH: 1.4MHz / QPSK

MODE	TX channel 20525	FREQUENCY RANGE	Above 1000MHz
ENVIRONMENTAL CONDITIONS	23deg. C, 70%RH	INPUT POWER	AC 120V/60HZ
TESTED BY	Jace Hu		
ANTENNA POLARITY & TEST DISTANCE: HORIZONTAL AT 3 M			

No.	Frequency MHz	Factor dB	Reading dBm	Emission dBm	Limit dBm	Margin dB	Tower / Table cm deg	
1	1673.00 (PK)	-12.76	-29.18	-41.94	-13.00	-28.94	100	0
2	2509.50 (PK)	-10.93	-39.51	-50.44	-13.00	-37.44	100	0

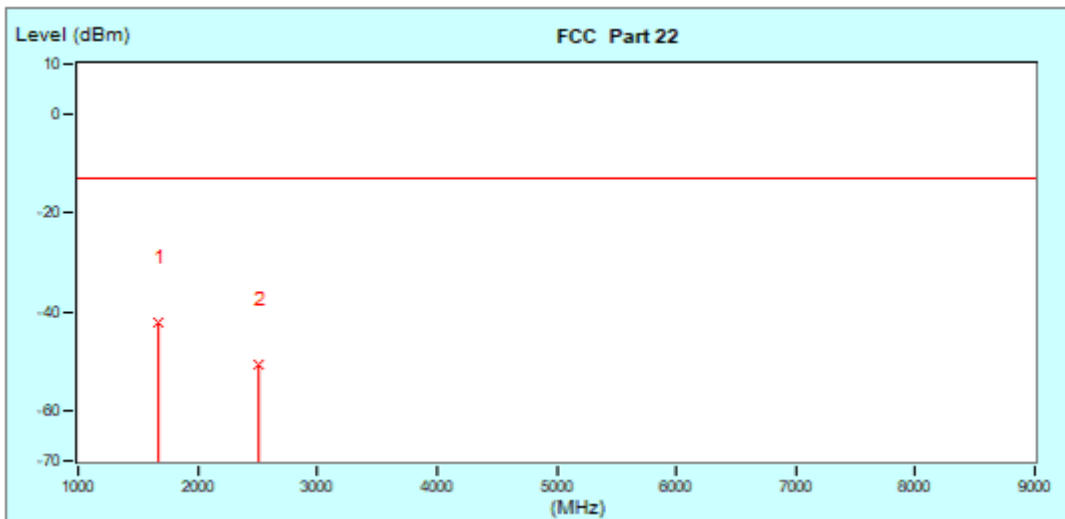



MODE	TX channel 20525	FREQUENCY RANGE	Above 1000MHz
ENVIRONMENTAL CONDITIONS	23deg. C, 70%RH	INPUT POWER	AC 120V/60HZ
TESTED BY	Jace Hu		
ANTENNA POLARITY & TEST DISTANCE: VERTICAL AT 3 M			

No.	Frequency MHz	Factor dB	Reading dBm	Emission dBm	Limit dBm	Margin dB	Tower / Table cm deg	
1	1873.00 (PK)	-12.76	-25.99	-38.75	-13.00	-25.75	100	0
2	2509.50 (PK)	-10.93	-42.13	-53.06	-13.00	-40.06	100	0

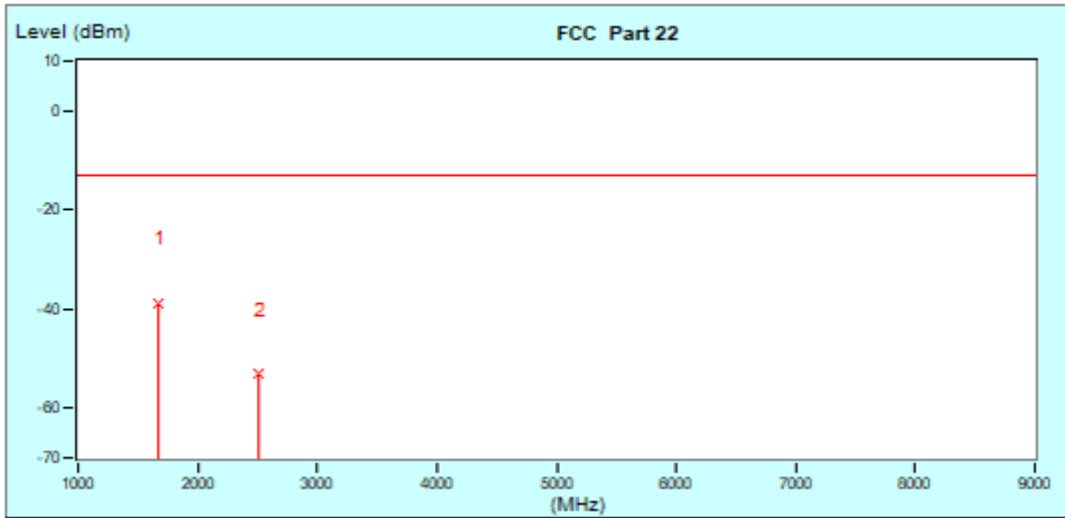



CHANNEL BANDWIDTH: 3MHz / QPSK

CH20415

MODE	TX channel 20415	FREQUENCY RANGE	Above 1000MHz
ENVIRONMENTAL CONDITIONS	23deg. C, 70%RH	INPUT POWER	AC 120V/60HZ
TESTED BY	Jace Hu		
ANTENNA POLARITY & TEST DISTANCE: HORIZONTAL AT 3 M			

No.	Frequency	Factor dB	Reading dBm	Emission dBm	Limit dBm	Margin dB	Tower / Table	
	MHz						cm	deg
1	1651.00 (PK)	-13.02	-29.81	-42.83	-13.00	-29.83	100	0
2	2476.50 (PK)	-10.84	-38.94	-49.78	-13.00	-36.78	100	0

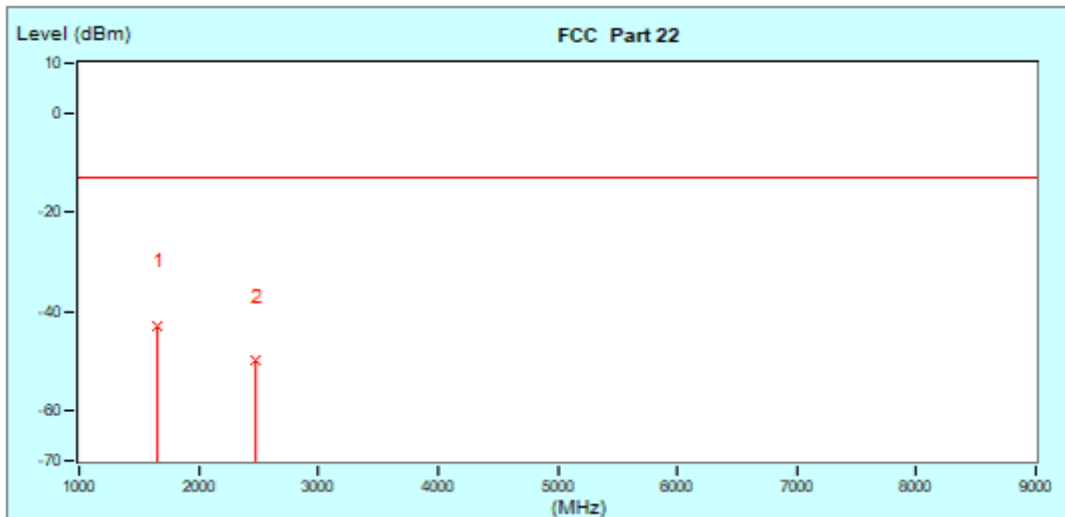



MODE	TX channel 20415	FREQUENCY RANGE	Above 1000MHz
ENVIRONMENTAL CONDITIONS	23deg. C, 70%RH	INPUT POWER	AC 120V/60HZ
TESTED BY	Jace Hu		
ANTENNA POLARITY & TEST DISTANCE: VERTICAL AT 3 M			

No.	Frequency MHz	Factor dB	Reading dBm	Emission dBm	Limit dBm	Margin dB	Tower / Table cm deg	
1	1651.00 (PK)	-13.02	-25.76	-38.78	-13.00	-25.78	100	0
2	2476.50 (PK)	-10.84	-39.50	-50.34	-13.00	-37.34	100	0

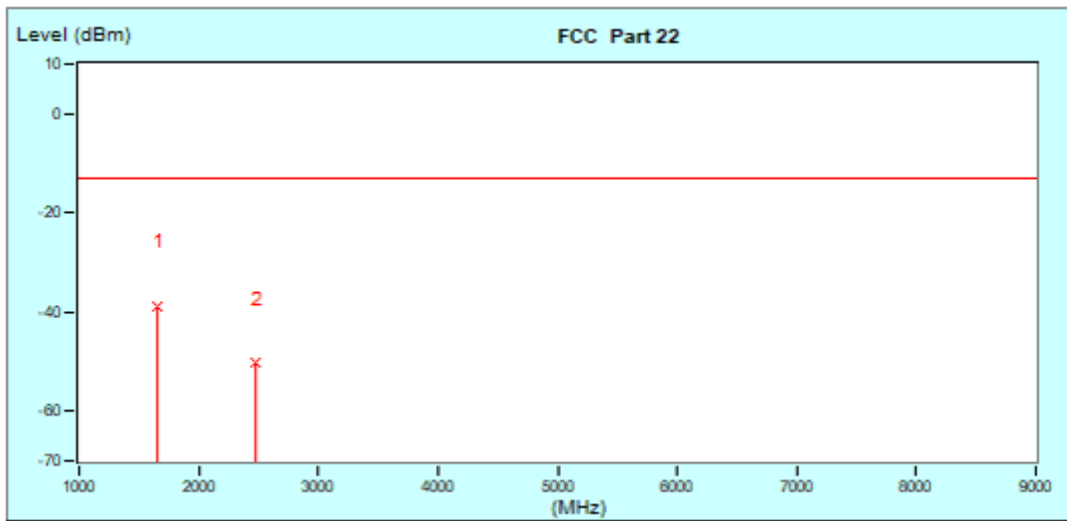



**BUREAU
VERITAS**

Test Report No.: W7L-P23100004RI02

CH20525

MODE	TX channel 20525	FREQUENCY RANGE	Above 1000MHz
ENVIRONMENTAL CONDITIONS	23deg. C, 70%RH	INPUT POWER	AC 120V/60HZ
TESTED BY	Jace Hu		
ANTENNA POLARITY & TEST DISTANCE: HORIZONTAL AT 3 M			

No.	Frequency	Factor	Reading	Emission	Limit	Margin	Tower / Table	
	MHz	dB	dBm	dBm	dBm	dB	cm	deg
1	1673.00 (PK)	-12.76	-30.74	-43.50	-13.00	-30.50	100	0
2	2509.50 (PK)	-10.93	-40.93	-51.86	-13.00	-38.86	100	0

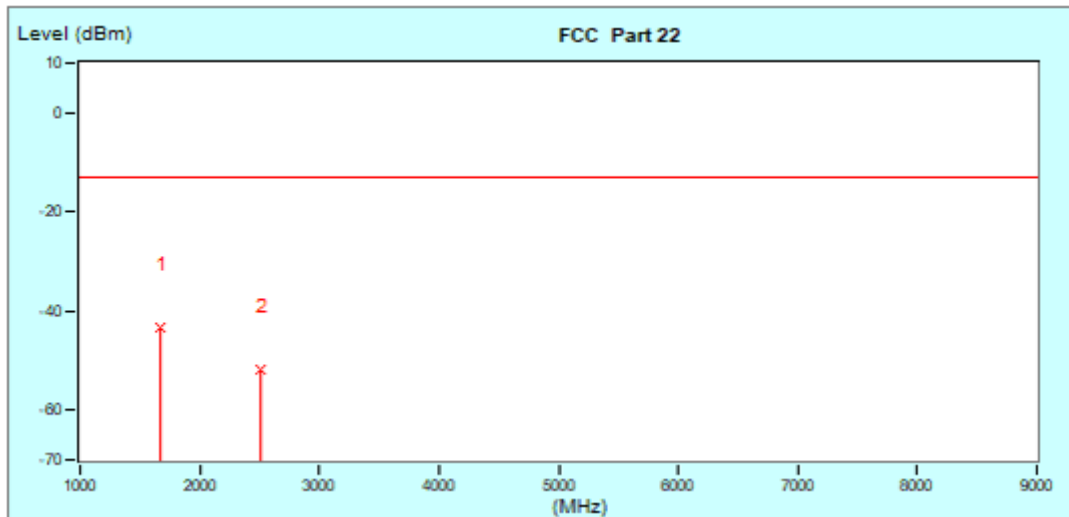



MODE	TX channel 20525	FREQUENCY RANGE	Above 1000MHz
ENVIRONMENTAL CONDITIONS	23deg. C, 70%RH	INPUT POWER	AC 120V/60HZ
TESTED BY	Jace Hu		
ANTENNA POLARITY & TEST DISTANCE: VERTICAL AT 3 M			

No.	Frequency MHz	Factor dB	Reading dBm	Emission dBm	Limit dBm	Margin dB	Tower / Table cm deg	
1	1673.00 (PK)	-12.76	-24.90	-37.66	-13.00	-24.66	100	0
2	2509.50 (PK)	-10.93	-42.11	-53.04	-13.00	-40.04	100	0

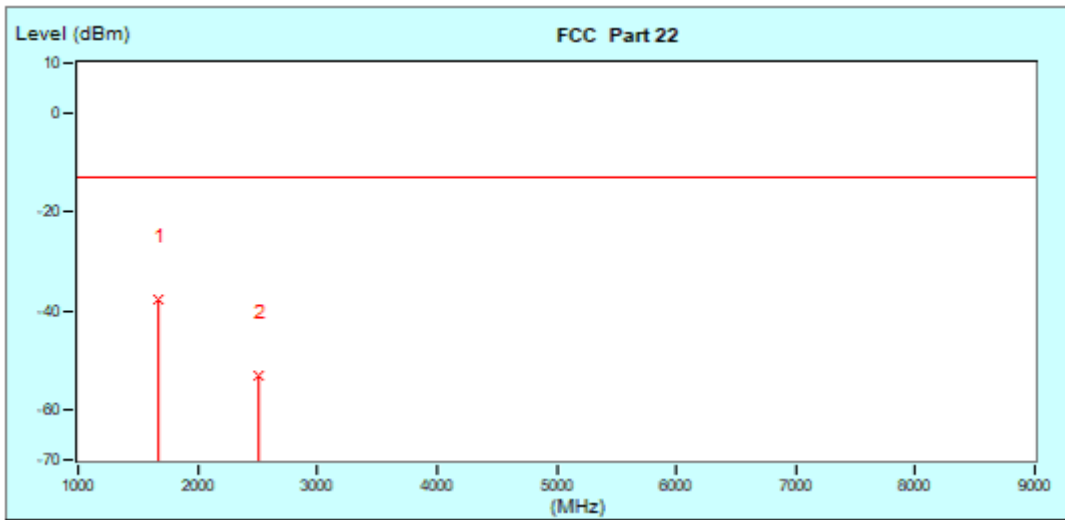



CH20635

MODE	TX channel 20635	FREQUENCY RANGE	Above 1000MHz
ENVIRONMENTAL CONDITIONS	23deg. C, 70%RH	INPUT POWER	AC 120V/60HZ
TESTED BY	Jace Hu		
ANTENNA POLARITY & TEST DISTANCE: HORIZONTAL AT 3 M			

No.	Frequency MHz	Factor dB	Reading dBm	Emission dBm	Limit dBm	Margin dB	Tower / Table cm deg	
1	1695.00 (PK)	-12.49	-31.46	-43.95	-13.00	-30.95	100	0
2	2542.50 (PK)	-10.93	-41.39	-52.32	-13.00	-39.32	100	0

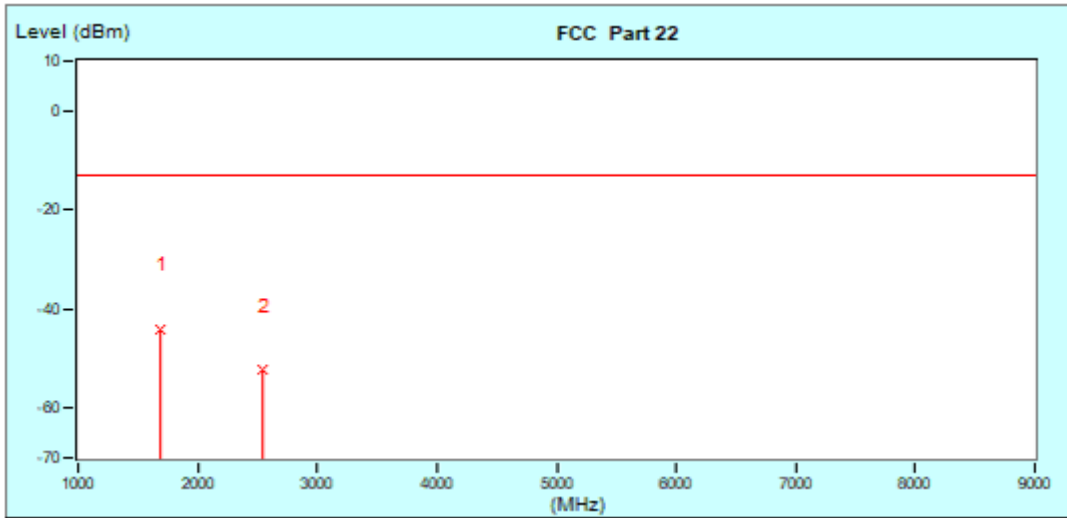



MODE	TX channel 20635	FREQUENCY RANGE	Above 1000MHz
ENVIRONMENTAL CONDITIONS	23deg. C, 70%RH	INPUT POWER	AC 120V/60HZ
TESTED BY	Jace Hu		
ANTENNA POLARITY & TEST DISTANCE: VERTICAL AT 3 M			

No.	Frequency MHz	Factor dB	Reading dBm	Emission dBm	Limit dBm	Margin dB	Tower / Table cm deg	
- 1	1695.00 (PK)	-12.49	-27.86	-40.35	-13.00	-27.35	100	0
2	2542.50 (PK)	-10.93	-39.93	-50.86	-13.00	-37.86	100	0

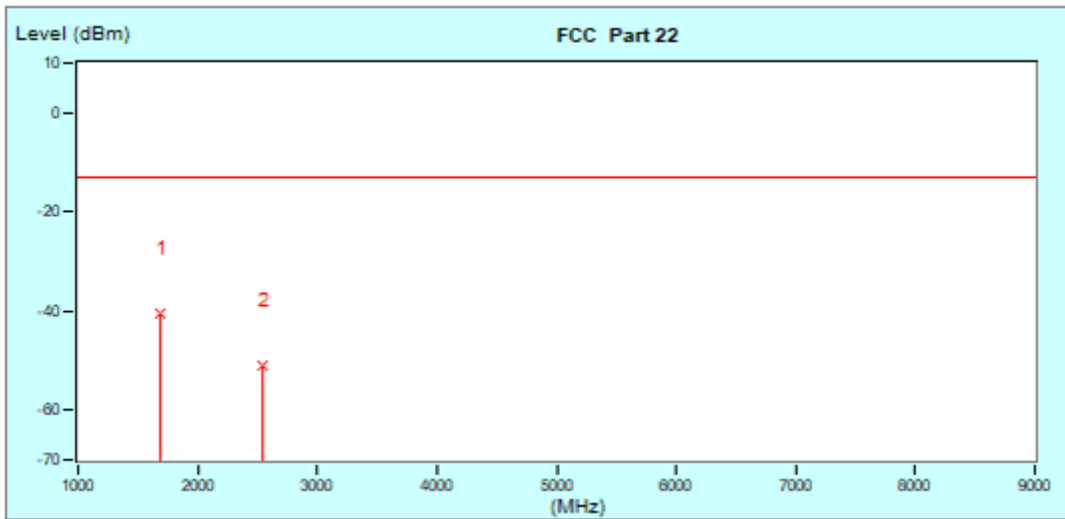



CHANNEL BANDWIDTH: 5MHz / QPSK

MODE	TX channel 20525	FREQUENCY RANGE	Above 1000MHz
ENVIRONMENTAL CONDITIONS	23deg. C, 70%RH	INPUT POWER	AC 120V/60HZ
TESTED BY	Jace Hu		
ANTENNA POLARITY & TEST DISTANCE: HORIZONTAL AT 3 M			

No.	Frequency MHz	Factor dB	Reading dBm	Emission dBm	Limit dBm	Margin dB	Tower / Table cm deg	
1	1673.00 (PK)	-12.76	-31.63	-44.39	-13.00	-31.39	100	0
2	2509.50 (PK)	-10.93	-42.00	-52.93	-13.00	-39.93	100	0

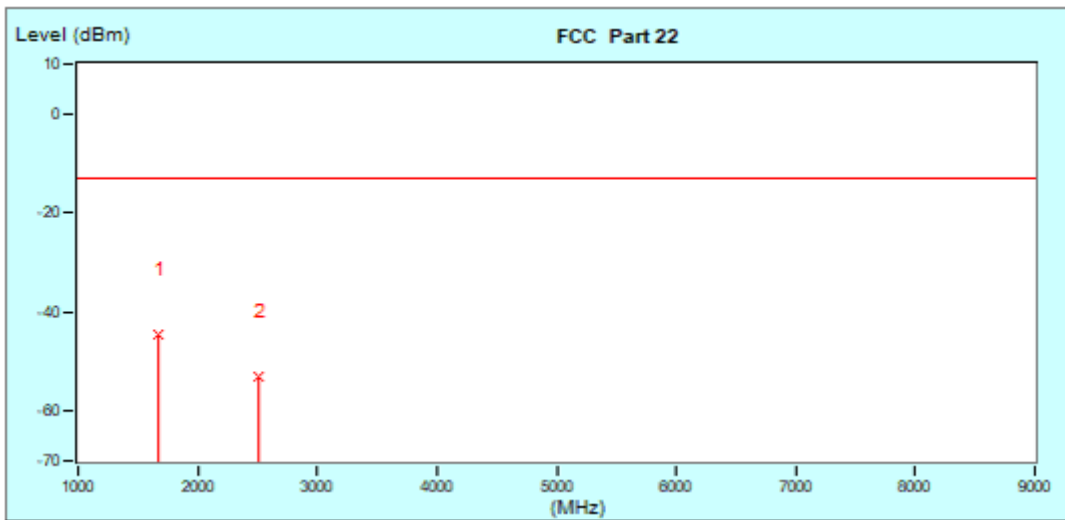



MODE	TX channel 20525	FREQUENCY RANGE	Above 1000MHz
ENVIRONMENTAL CONDITIONS	23deg. C, 70%RH	INPUT POWER	AC 120V/60HZ
TESTED BY	Jace Hu		
ANTENNA POLARITY & TEST DISTANCE: VERTICAL AT 3 M			

No.	Frequency MHz	Factor dB	Reading dBm	Emission dBm	Limit dBm	Margin dB	Tower / Table cm deg	
1	1673.00 (PK)	-12.76	-28.02	-40.78	-13.00	-27.78	100	0
2	2509.50 (PK)	-10.93	-41.89	-52.82	-13.00	-39.82	100	0

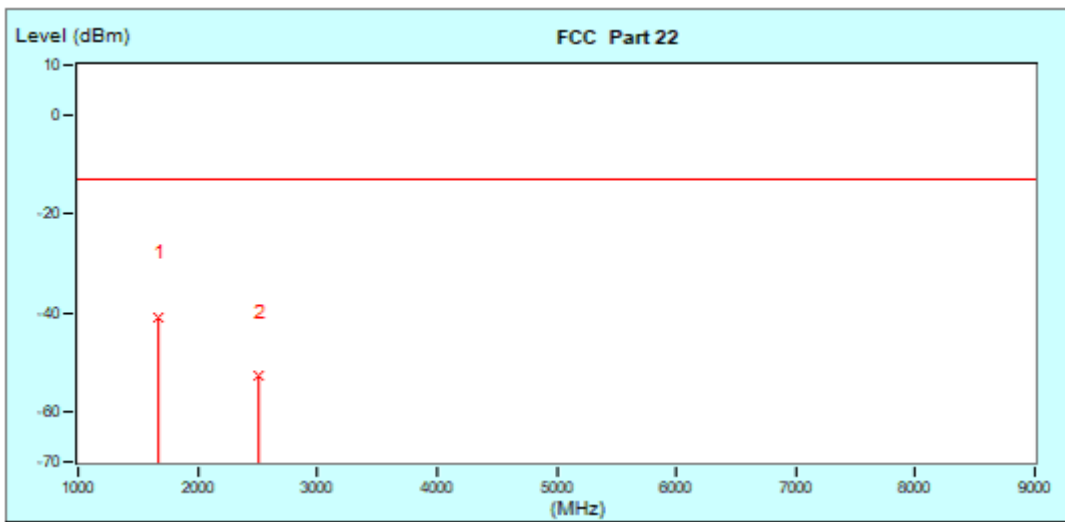



CHANNEL BANDWIDTH: 10MHz / QPSK

MODE	TX channel 20525	FREQUENCY RANGE	Above 1000MHz
ENVIRONMENTAL CONDITIONS	23deg. C, 70%RH	INPUT POWER	AC 120V/60HZ
TESTED BY	Jace Hu		
ANTENNA POLARITY & TEST DISTANCE: HORIZONTAL AT 3 M			

No.	Frequency MHz	Factor dB	Reading dBm	Emission dBm	Limit dBm	Margin dB	Tower / Table cm deg	
1	1673.00 (PK)	-12.76	-32.83	-45.59	-13.00	-32.59	100	0
2	2509.50 (PK)	-10.93	-39.24	-50.17	-13.00	-37.17	100	0

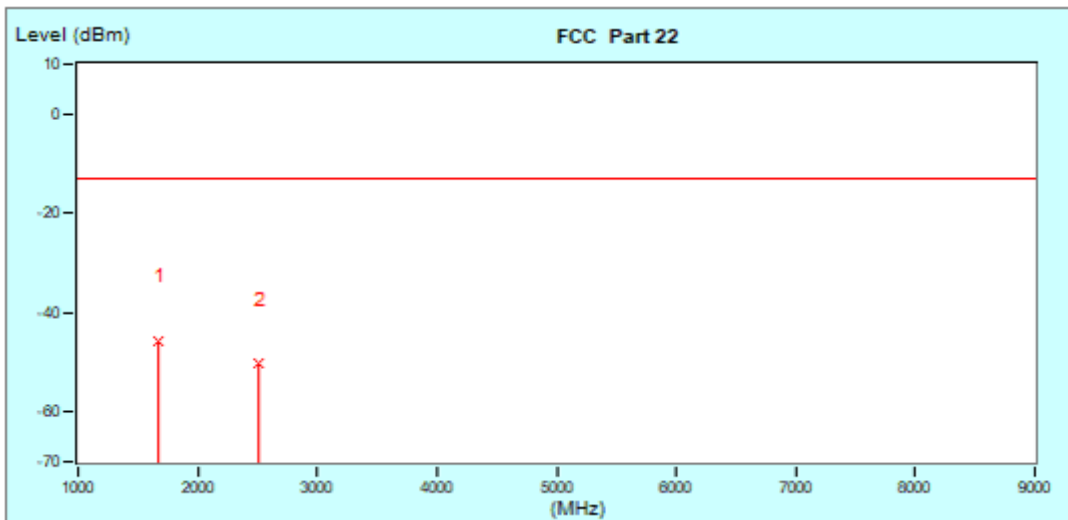



**BUREAU
VERITAS**

Test Report No.: W7L-P23100004RI02

MODE	TX channel 20525	FREQUENCY RANGE	Above 1000MHz
ENVIRONMENTAL CONDITIONS	23deg. C, 70%RH	INPUT POWER	AC 120V/60HZ
TESTED BY	Jace Hu		
ANTENNA POLARITY & TEST DISTANCE: VERTICAL AT 3 M			

No.	Frequency MHz	Factor dB	Reading dBm	Emission dBm	Limit dBm	Margin dB	Tower / Table cm deg	
1	1873.00 (PK)	-12.76	-27.72	-40.48	-13.00	-27.48	100	0
2	2509.50 (PK)	-10.93	-41.45	-52.38	-13.00	-39.38	100	0

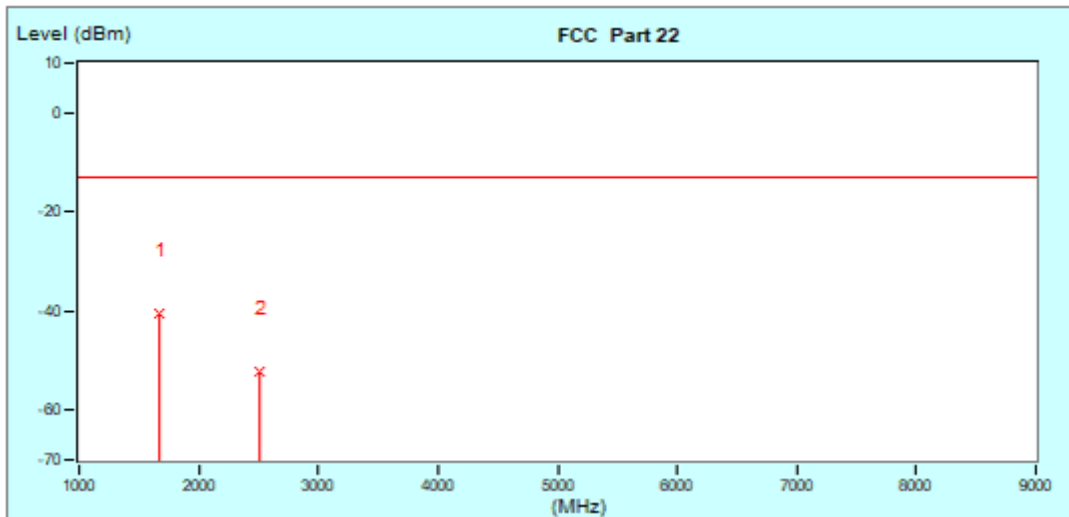



3.7 PEAK TO AVERAGE RATIO

3.7.1 LIMITS OF PEAK TO AVERAGE RATIO MEASUREMENT

In measuring transmissions in this band using an average power technique, the peak to-average ratio (PAR) of the transmission may not exceed 13 dB

3.7.2 TEST SETUP

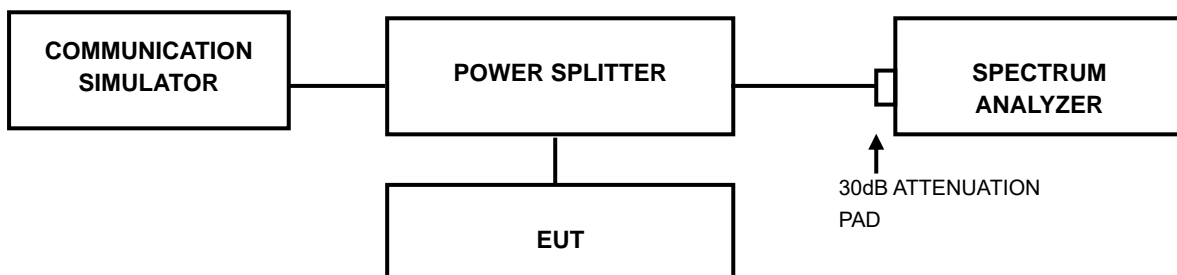

3.7.3 TEST PROCEDURES

1. Set resolution/measurement bandwidth \geq signal's occupied bandwidth;
2. Set the number of counts to a value that stabilizes the measured CCDF curve;
3. Record the maximum PAPR level associated with a probability of 0.1%.



BUREAU
VERITAS

Test Report No.: W7L-P23100004RI02

3.7.4 TEST RESULTS

Please Refer to Module report R1811A0536-R7.



Test Report No.: W7L-P23100004RI02

4 INFORMATION ON THE TESTING LABORATORIES

We, BV 7Layers Communications Technology (Shenzhen) Co. Ltd, were founded in 2015 to provide our best service in EMC, Radio, and Telecom. Our laboratories are accredited and approved according to ISO/IEC 17025.

If you have any comments, please feel free to contact us at the following:

Shenzhen EMC/RF Lab:

Tel: +86 755 8869 6566

Fax: +86 755 8869 6577

Email: customerservice.sw@bureauveritas.com

Web Site: www.adt.com.tw

The address and road map of all our labs can be found in our web site also.



BUREAU
VERITAS

Test Report No.: W7L-P23100004RI02

5 MODIFICATIONS RECORDERS FOR ENGINEERING CHANGES TO THE EUT BY THE LAB

No any modifications are made to the EUT by the lab during the test.

---END---