

B Series Evaluation Board

This is a simple breakout board for Particle's B series of cellular IoT modules. It breaks out all of its pins via easy to use headers. The board features a redundant USB port, connector for the LiPo battery, a barrel jack power connector, buttons, RGB LED, and charge status LED.

The Eagle CAD design files, Gerber files, and bill of materials can be found in the [SoM eval board GitHub repository](#).

Block Diagram

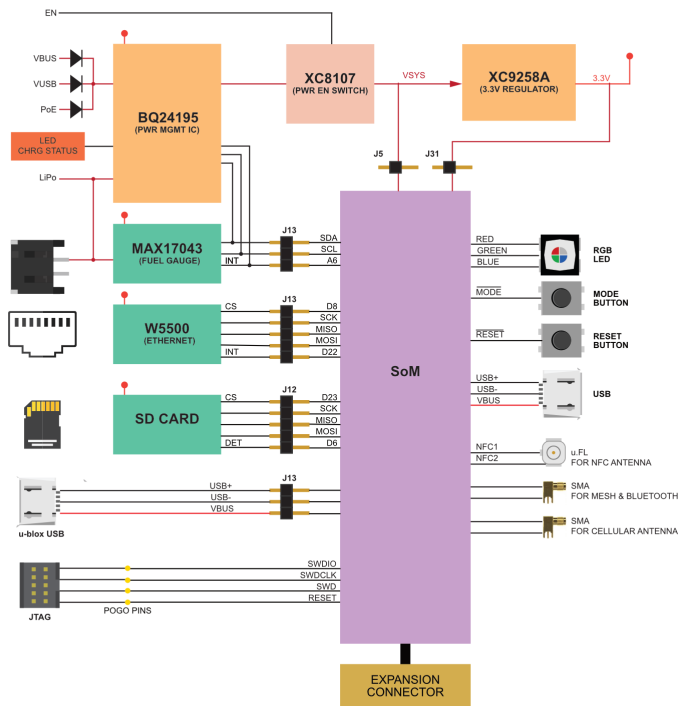

Description

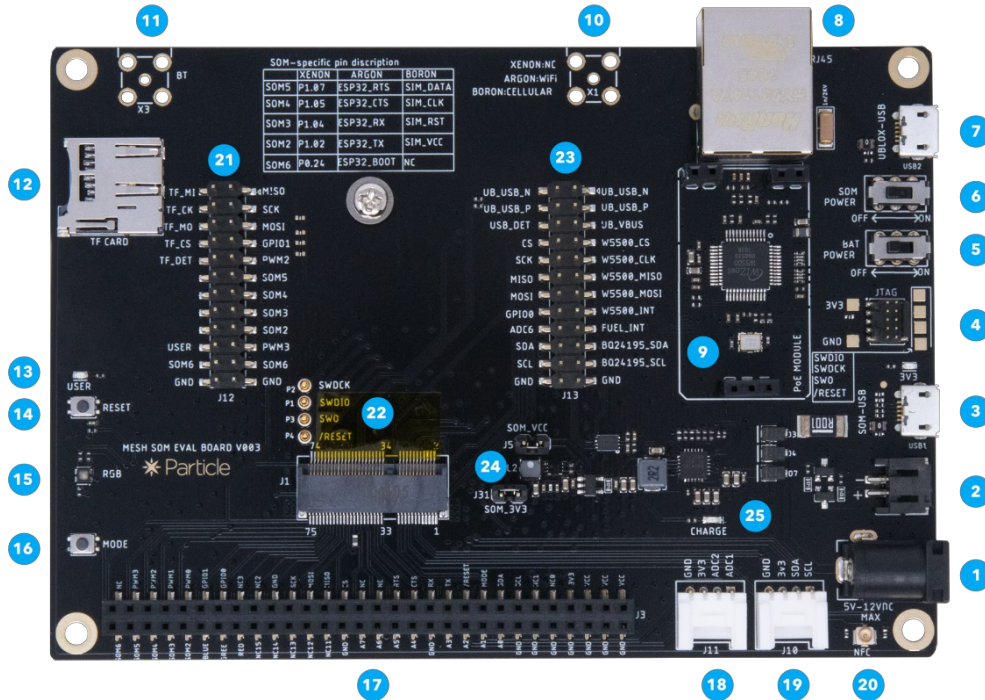

Num	ID	Description
1	External Power	5-12 VDC. Minimum power requirements are 5VDC @500mA (when the LiPo battery) or 5VDC @2000mA (without LiPo battery).
2	LiPo Battery connector	Plug in the LiPo battery here.
3	SoM USB port	This is the module's main USB port that connects to the microcontroller.
4	JTAG connector	This can plug directly into the Particle debugger ribbon cable.
5	Battery switch	Controls power between the LiPo connector and the charge controller.
6	SoM power switch	Controls 3V3 power to the SoM
7	u-blox USB port	This USB port connects directly to the u-blox module for firmware updates.
8	Ethernet connector	RJ45 connector for twisted pair Ethernet, 10 or 100 Mbit/sec.
9	PoE connector	Connect for the Particle PoE adapter for power-over-Ethernet.
10	Cellular antenna	Connector for an external SMA connected cellular antenna.
11	Bluetooth antenna	Connector for an external SMA connected antenna for Bluetooth networking.
12	TF/SD Card	MicroSD card slot.
13	User LED	Blue LED connected to pin D7.
14	Reset Button	This is same as the RESET button on the Boron.
15	RGB LED	System status indicator RGB LED.
16	Mode Button	This is the same as the MODE button on the Boron.
17	Expansion Connector	Allows easy access to SoM IO pins.
18	Grove Analog Port	Connects to Seeed Studio Grove analog and digital boards.

19	Grove I2C Port	Connects to Seeed Studio Grove I2C boards.
20	NFC Antenna	U.FL connector for an NFC antenna (optional).
21	Jumpers J12	Enable or disable various features on the evaluation board.
22	SoM connector	M.2 connector for the B Series SoM.
23	Jumpers J13	Enable or disable various features on the evaluation board.
24	Power Jumpers	Enable or disable power from the evaluation board.
25	Charge LED	Indicate LiPo is charging.

JUMPERS J12

These pins are intended to be connected across using removable two-pin jumpers to connect features on the board to standard ports.

Feature	Feature Pin	SoM Pin	B Series Pin
MicroSD	SD_MI	MISO	MISO
	SD_CK	SCK	SCK
	SD_MO	MOSI	MOSI
	SD_CS1	PWM1	D5
	SD_DECT	PWM2	D6
D7 LED	USER	PWM3	D7
	GND	GND	GND

JUMPERS J13

These pins are intended to be connected across using removable two-pin jumpers to connect features on the board to standard ports.

B Series Pin	SoM Pin	Feature Pin	Feature
	UB_USB_N	UB_USB_N	u-blox USB
	UB_USB_P	UB_USB_N	
	USB_DET	UB_VBUS	
D8	CS	ETH_CS	Ethernet
SCK	SCK	ETH_CLK	
MISO	MISO	ETH_MISO	
MOSI	MOSI	ETH_MOSI	
D22	GPIO0	ETH_INT	
A6	ADC6	PM_INT	Fuel Gauge & PMIC
D0	SDA	PM_SDA	PMIC
D1	SCL	PM_SCL	PMIC

For more information about Ethernet, see the application note [AN037 Ethernet](#).

POWER JUMPERS

Jumper	Name
J5	SOM_VCC
J31	SOM_3V3

EXPANSION CONNECTOR

B Series Pin	SoM Pin	SoM Pin	B Series Pin
	SOM9	NC	
SIM_DATA	SOM8	PWM3	D7
SIM_CLK	SOM7	PWM2	D6
SIM_RST	SOM6	PWM1	D5
SIM_VCC	SOM5	PWM0	D4
	BLUE	GPIO1	D23
	GREEN	GPIO0	D22
	RED	NC	
	NC	NC	
	NC	GND	
	NC	SCK	D13
	NC	MOSI	D12
	NC	MISO	D11
	GND	CS	D8
A7/D20	ADC7	NC	
A6/D21	ADC6	NC	
A5/D14	ADC5	RTS	D2
A4/D15	ADC4	CTS	D3
	GND	RX	RX/D10
A3/D16	ADC3	TX	TX/D9
A2/D17	ADC2	RESET	
A1/D18	ADC1	MODE	
A0/D19	ADC0	SDA	D0
	GND	SCL	D1
	GND	NC	
	GND	NC	
	GND	VCC	
	GND	VCC	
	GND	VCC	

PWM DIFFERENCES

On the B Series SoM, pins D4, D5, D7, A0, A1, A6, and A7 can be used for PWM. Pins are assigned a PWM group. Each group must share the same frequency and resolution, but individual pins in the group can have a different duty cycle.

- Group 2: Pins A0, A1, A6, and A7.
- Group 1: Pins D4, D5, and D6.
- Group 0: Pin D7 and the RGB LED. This must use the default resolution of 8 bits (0-255) and frequency of 500 Hz.

On Gen 3 Feather devices (Argon, Boron, Xenon), pins A0, A1, A2, A3, D2, D3, D4, D5, D6, D7, and D8 can be used for PWM. Pins are assigned a PWM group. Each group must share the same frequency and resolution, but individual pins in the group can have a different duty cycle.

- Group 3: Pins D2, D3, A4, and A5.
- Group 2: Pins A0, A1, A2, and A3.
- Group 1: Pins D4, D5, D6, and D8.
- Group 0: Pin D7 and the RGB LED. This must use the default resolution of 8 bits (0-255) and frequency of 500 Hz.

These rules also apply to `tone()` (square wave with 50% duty cycle), however since each group must share the same frequency you can only generate two different simultaneous tones of different frequencies on the B Series SoM. You cannot generate tone on group 0.

Basic Setup

The basic setup for the B series to be operational is shown below:

- Plug the cellular antenna into the U.FL connector labeled **CELL** on the SoM. Remember never to power up this board without the antenna being connected. There is potential to damage the transmitter of the u-blox module if no antenna is connected.
- If you are going to use mobile app setup or BLE, connect the 2.4 GHz antenna (the smaller one) to the **BT** U.FL connector on the SoM.
- Connect power the USB (3) or a LiPo battery (4).
- Turn on the appropriate power switches (5).

USING THE PMIC AND FUEL GAUGE (RECOMMENDED)

There is support for bq24195 PMIC and MAX17043 fuel gauge in Device OS so you don't need to add any additional configuration.

PMIC	nRF52 Pin	SoM Pin	SoM Pin Number
PM_INT	P0.05	A6	45
PM_SDA	P1.13	D0	22
PM_SCL	P1.15	D1	20

It requires these jumpers, which should be installed at the factory:

- ADC6 to PM_INT
- SDA to PM_SDA
- SCL to PM_SCL

USING THE MICROSD CARD

To use the MicroSD card, you must add the jumpers:

- SD_MISO to SPI MISO
- SD_SCK to SPI SCK
- SD_MOSI to SPI MOSI
- SD_CS to PWM1 (D5)
- SD_DECT to PWM2 (D6) (optional)

You will normally use this with the [SdFat](#) library.

With the jumpers installed, it will use the secondary SPI (SPI1) and pin D5 as the chip select.

Micro SD	nRF52 Pin	SoM Pin	SoM Pin Number
SD_MISO	P1.14	D11 / SPI MISO	50
SD_SCK	P1.15	D13 / SPI SCK	54
SD_MOSI	P1.13	D12 / SPI MOSI	52
SD_CS	P1.10	D5 / PWM1	68
SD_DET	P1.11	D6 / PWM2	70

USING ETHERNET

To use Ethernet, you must add the jumpers:

- CS to ETH_CS
- SCK to ETH_SCK
- MISO to ETH_MISO
- MOSI to ETH_MOSI
- GPIO0 to ETH_INT

With the jumpers installed, it will use the primary SPI and pins D8 as the chip select and D22 as the interrupt pin.

W5500	nRF52 Pin	SoM Pin	SoM Pin Number
ETH_CS	P1.03	D8	48
ETH_MISO	P1.14	D11 / SPI MISO	50
ETH_SCK	P1.15	D13 / SPI SCK	54
ETH_MOSI	P1.13	D12 / SPI MOSI	52
RST_N	P0.02	A7 (D20)	47
ETH_INT	P0.24	D22	62

USING THE GROVE CONNECTORS

J11	nRF52 Pin	SoM Pin	SoM Pin Number
GND			
3V3			
ADC2	P0.28	A2	35
ADC1	P0.04	A1	33

J10	nRF52 Pin	SoM Pin	SoM Pin Number
GND			
3V3			
SDA	P1.13	D0	22
SCL	P1.15	D1	20

Evaluation Board Schematics

PMIC

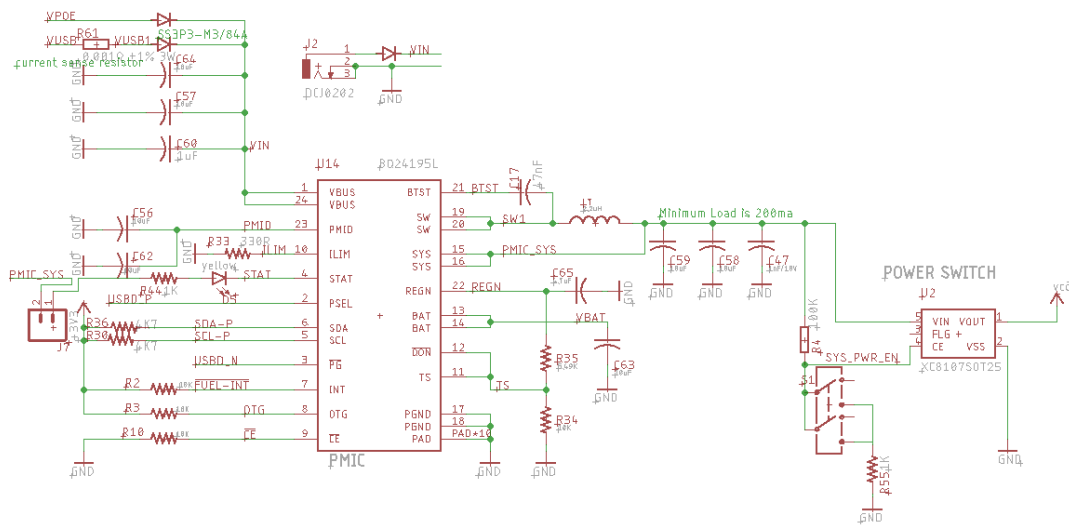

FUEL GAUGE

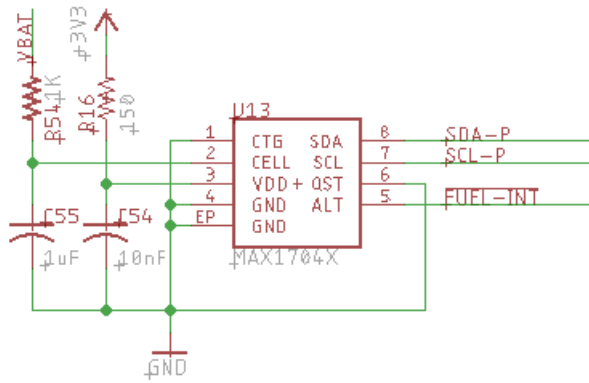

3.3V REGULATOR

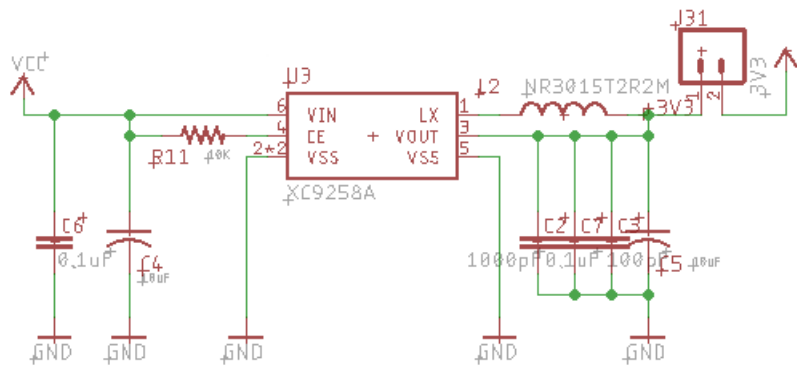

ETHERNET

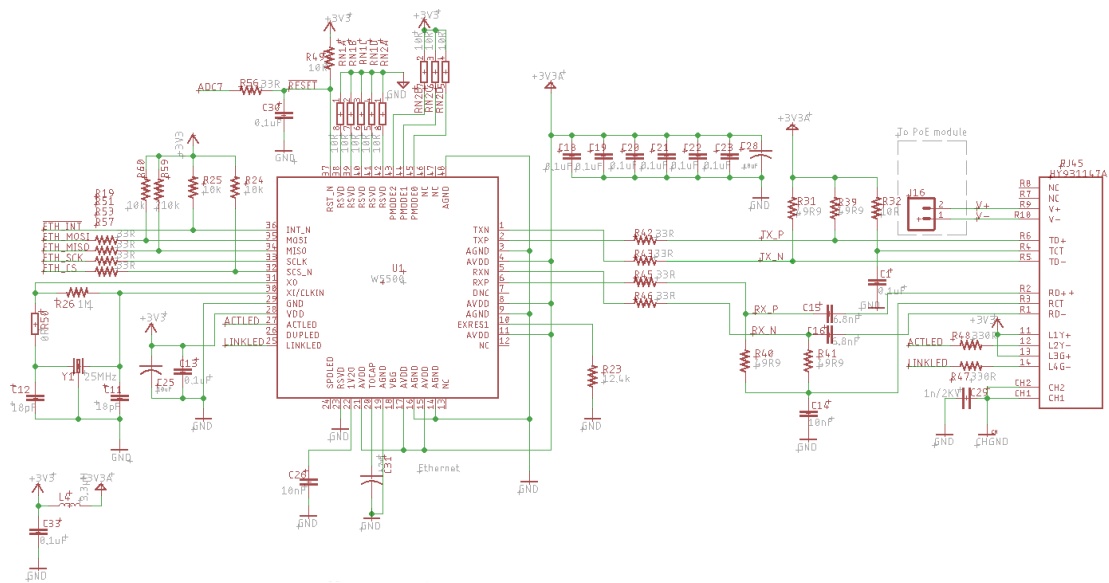

SD CARD

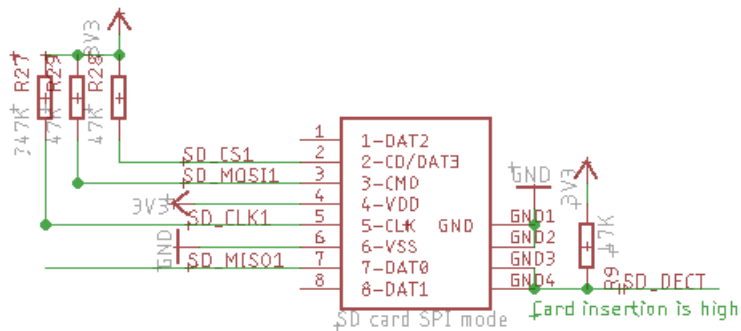

Mechanical specifications

DIMENSIONS AND WEIGHT

Parameter	Value
Width	91 mm
Length	142.5 mm
Thickness	15.5 mm
Weight	71.8 grams (including PoE module)

Revision history

Revision	Date	Author	Comments
001	29 Apr 2019	RK	Initial Release
002	21 Jan 2020	RK	Remove mesh
003	3 Feb 2020	RK	Correct pins for SD card
004	20 Jul 2022	RK	Correct pins for SD and Ethernet SPI, which are SPI not SPII
005	9 Sep 2023	RK	Correct length