

B504 Datasheet	4
Functional description	5
OVERVIEW	5
FEATURES	5
MODEL COMPARISON	5
DEVICE OS SUPPORT	6
Migration information	7
B404X, B404, B402 MIGRATION	7
B524, B523 MIGRATION	7
Interfaces	8
BLOCK DIAGRAM	8
POWER	8
VCC	8
3V3	8
VBus	9
ANTENNA	10
Certified cellular antenna	10
Certified BLE antenna	11
Certified NFC antenna	11
CERTIFIED GNSS ANTENNAS	12
General antenna guidance	12
PERIPHERALS AND GPIO	12
JTAG AND SWD	13
Memory map	14
NRF52840 FLASH LAYOUT OVERVIEW	14
EXTERNAL SPI FLASH LAYOUT OVERVIEW (DFU OFFSET: 0X80000000)	14
Pins and button definitions	15
PINOUT DIAGRAM	15
COMMON SOM PINS	15
GPIO AND PORT LISTING	15
ADC (ANALOG TO DIGITAL CONVERTER)	16
UART SERIAL	16
SPI	17
I2C	17
PWM	17
USB	18
RGB LED	18
SETUP AND RESET BUTTON	19
PIN DESCRIPTION	19
COMPLETE MODULE PIN DETAILS	21
1 GND	21
2 VCC	21
3 GND	22
4 VCC	22
5 GND	22
6 VCC	22

7 GND	22
8 VCC	22
9 GND	22
10 3V3	23
11 USBDATA+	23
12 3V3	23
13 USBDATA-	23
14 NC	23
15 GND	23
16 VUSB	23
17 NFC1	24
18 NC	24
19 NFC2	24
20 D1	24
21 GND	24
22 D0	24
23 A0	25
32 MODE	25
33 A1	25
34 RST	25
35 A2	26
36 TX	26
37 A3	26
38 RX	26
39 AGND	27
40 D3	27
41 A4	27
42 D2	27
43 A5	28
44 CELL USBD+	28
45 A6	28
46 CELL USBD-	29
47 A7	29
48 D8	29
49 AGND	29
50 MISO	29
51 NC	30
52 MOSI	30
53 NC	30
54 SCK	30
55 NC	30
56 GND	31
57 NC	31
58 NC	31
59 NC	31
60 NC	31
61 RGBR	31
62 D22	31
63 RGBG	32

64 D23	32
65 RGBB	32
66 D4	32
67 SIM_VCC	32
68 D5	33
69 SIM_RST	33
70 D6	33
71 SIM_CLK	33
72 D7	33
73 SIM_DATA	34
74 CELL_VBUS	34
75 RI	34
LED STATUS	34
System RGB LED	34
PMIC NOTES	34
Technical specifications	36
ABSOLUTE MAXIMUM RATINGS [1]	36
Supply voltages	36
RECOMMENDED OPERATING CONDITIONS	36
POWER CONSUMPTION	37
RADIO SPECIFICATIONS	38
Nordic Semiconductor nRF52840 for BLE	38
Nordic Semiconductor nRF52840 for NFC tag	38
Quectel EG91-NAX	38
I/O CHARACTERISTICS	39
Mechanical specifications	40
DIMENSIONS AND WEIGHT	40
3D MODELS	40
MECHANICAL DRAWING	40
MATING CONNECTOR AND LAND PATTERN	41
SCREW ASSEMBLY	42
DESIGN CONSIDERATIONS	42
Product handling	44
ESD PRECAUTIONS	44
CONNECTORS	44
Assembly	45
CONFORMAL COATINGS	45
Default settings	46
FCC warnings and end product labeling requirements	47
Country compatibility	48
ADDITIONAL COUNTRIES	48
Ordering information	50
Revision history	51

# B504 Datasheet



# Functional description

## OVERVIEW

---

The B-Series System-on-a-Module (SoM) is a cellular device with support for BLE (Bluetooth LE). It is based on the Nordic nRF52840 microcontroller.

The B-Series is designed to be integrated into your circuit board design, plugging into a M.2 NGFF connector on your board, allowing the module to be changed or upgraded easily.

## FEATURES

---

- Quectel EG91-NAX cellular modem
- LTE Cat 1 module with 3G fallback with Americas bands
- Support for United States, Canada, and Mexico only
- 3GPP E-UTRA Release 13
- LTE Cat 1 bands: 2, 4, 5, 12, 13, 25, 26
- UMTS (3G) bands: 2, 4, 5
- Embedded Particle EtherSIM
- GNSS (GPS)
- Nordic Semiconductor nRF52840 SoC
- ARM Cortex-M4F 32-bit processor @ 64MHz
- 1MB flash, 256KB RAM
- Bluetooth 5: 2 Mbps, 1 Mbps, 500 Kbps, 125 Kbps
- Supports DSP instructions, HW accelerated Floating Point Unit (FPU) and encryption functions
- Up to +8 dBm TX power (down to -20 dBm in 4 dB steps)
- NFC-A tag
- On-module additional 4MB SPI flash
- 24 mixed signal GPIO (8 x Analog, 8 x PWM), UART, I2C, SPI
- USB 2.0 full speed (12 Mbps)
- JTAG (SWD) pins
- Pins for RGB LED used for connection status
- Pins for reset and mode buttons
- On-module MFF2 Particle SIM
- Three on-module U.FL connectors for external antennas
- Connects to your base board or eval board that has a Particle M.2 connector
- FCC (United States) certified
- RoHS compliant (lead-free)

## MODEL COMPARISON

---

	<b>B404X</b>	<b>B404</b>	<b>B402</b>	<b>B524</b>	<b>B523</b>	<b>B504</b>
Region	NorAm	NorAm	NorAm	EMEA	Europe	Americas
EtherSIM	✓	✓		✓		✓
Supply Secure	✓			✓		✓
Lowest power (LTE Cat M1)	✓	✓	✓			
Fastest speed (LTE Cat 1)				✓	✓	✓
Cellular fallback				3G, 2G	3G, 2G	3G
Lifecycle	GA	NRND	Deprecated	GA	Deprecated	In development

- EtherSIM devices generally have a larger number of carriers and more may be added in the future
- NorAm: North America (United States, Canada, and Mexico)

- Americas: North America, Central, and South America (not all countries supported)
- LTE Cat M1: Low-power cellular intended for IoT devices
- LTE Cat 1: Available in more countries and has higher data rates
- EMEAA: Europe, Middle East, Africa, and Asia (not all countries supported)
- NRND: Not recommended for new designs
- See the [Carrier list](#) for specific carrier and country compatibility
- See the [Supply secure FAQ](#) for more information
- See [Lifestyle stages](#) for more information

## DEVICE OS SUPPORT

---

The B504 requires Device OS 5.0 or later. Using the most recent version 5.x or 6.x version is recommended.

The B504 is platform `b5som`, not `bsom` used by the B404X. While source code is compatible across both B-Series SoM models, binaries must be compiled separately for each.

Additionally, products can only contain one platform. Thus if you have both B404X and B504, they must be in separate products. You can, however, put the B504 and B524/B523 devices in the same product.

For information on upgrading Device OS, see [Version information](#). For the latest version shipped from the factory, see [Manufacturing firmware versions](#) page. See also [Long Term Support \(LTS\) releases](#).

# Migration information

The B504 is similar to the B524, except for the cellular bands supported. The B504 contains a Quectel EG91-NAX cellular modem and the B524 contains a Quectel EG91-E cellular modem. They are the same physical size and software compatible.

<b>Migrating from</b>	<b>Information</b>
B404X, B404, B402	Recompile source for b5som platform, see below
B524, B523	Upgrade Device OS version if necessary
Boron	<a href="#">B-Series from Boron or Argon migration guide</a>
E-Series	<a href="#">B-Series from E-Series migration Guide</a>
Electron	<a href="#">B-Series from Electron migration Guide</a>

## **B404X, B404, B402 MIGRATION**

---

- Recompile source for b5som platform.
- Upgrade Device OS to 5.x or later if necessary.
- Verify that power requirements for VCC are met, as the B504 requires more power than the B404X/B404/B402.
- Use the antenna the B504 was certified with, not previous antennas.

## **B524, B523 MIGRATION**

---

- Upgrade Device OS to 5.x or later if necessary.
- Use the antenna the B504 was certified with, not previous antennas.

# Interfaces

## BLOCK DIAGRAM

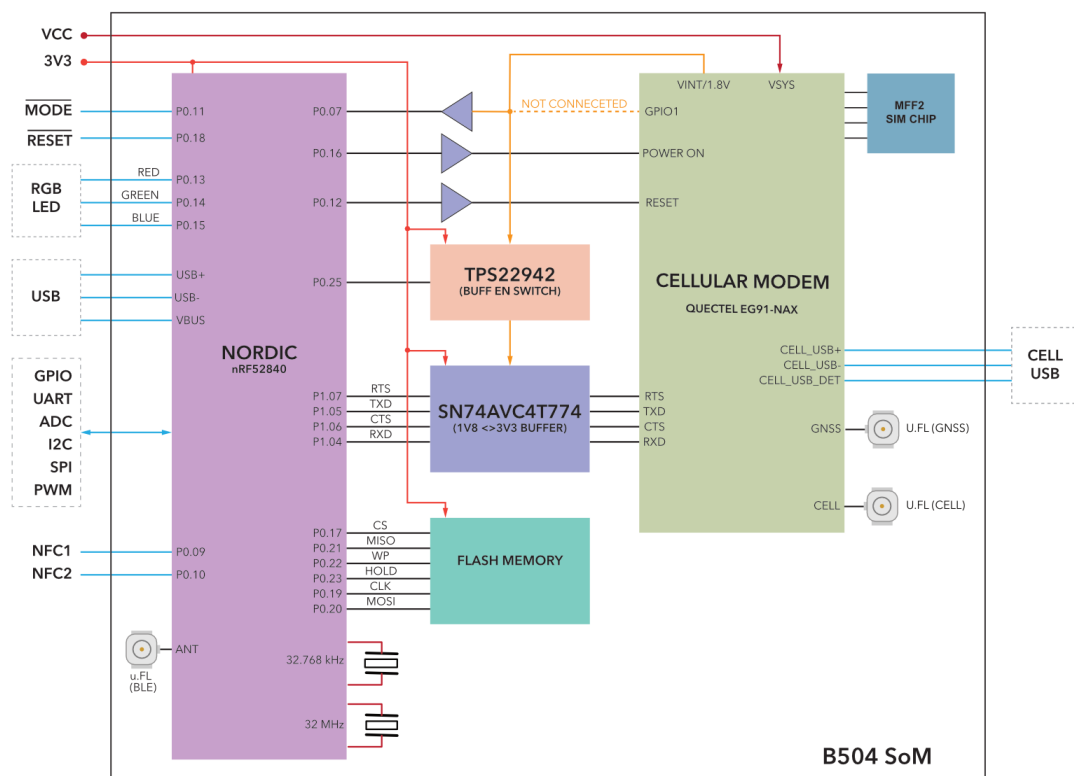

## POWER

### VCC

VCC is used to supply power to the Quectel EG91-NAX cellular module. The recommended input voltage range on this pin is between 3.6V to 4.2V DC. This can be connected directly to a 3.7V LiPo battery. Make sure that the supply can handle currents of at least 2 A.

If you are not using a battery, or using a battery of a different voltage, you should use a regulator to supply 3.7V to 4.2V at 2A. You may want to add additional bulk capacitors to handle the short, high current peak usage when the cellular modem is transmitting. If your board contains a bq24195 PMIC, see [PMIC notes](#), below, for additional information.

Note that the B504 requires 2000 mA on VCC, unlike the B404X which only 600 mA.

### 3V3

3V3 is used to supply power to nRF52840, logic ICs, memory, etc.. The 3V3 input voltage range is between 3V to 3.6V DC, but 3.3V is recommended. Make sure that the supply can handle a minimum of 150 mA, however we recommend a minimum of 500 mA supplied from your base board to allow for compatibility with future modules.

These limits do not include any 3.3V peripherals on your base board, so that may increase the current requirements.

Power supply requirements:

- 3.3V output
- Maximum 5% voltage drop
- 100 mV peak-to-peak ripple maximum



- 500 mA minimum output current at 3.3V recommended for future compatibility
- Maintain these values at no-load as well as maximum load

We do not recommend using a single 3.6V supply for both VCC and 3V3 as the cellular modem performance may be lower below 3.7V. Use two separate regulators for best results.

### **VBus**

VBus is connected to the USB detect pin of nRF52840 to enable the USB interface. The recommended input voltage range is between 4.35V to 5.5V DC.

## ANTENNA

There are four radios on the B504 module:

- BLE radio (part of nRF52840 MCU)
- NFC tag receiver (part of nRF52840 MCU)
- Cellular radio (Quectel EG91-NAX)
- GNSS (GPS) receiver (part of Quectel EG91-NAX)

We have provided three u.FL connectors to plug in the cellular, BLE antenna, and GNSS antennas.



Number	Label	Purpose
1	BT	Bluetooth antenna (optional)
2	CELL	Quectel cellular modem antenna
3	GNSS	GNSS (GPS) antenna (optional)

The NFC antenna connection is provided through the M.2 connector.

If you are not using BLE, NFC, or GNSS, you can omit those antennas.

### Certified cellular antenna

The B504 is certified with the following cellular antenna:

Antenna	SKU	Details	Links
Wide band LTE cell antenna [x1]	PARANTCW1EA	B504 and M-SoM	<a href="#">Datasheet</a>
Wide band LTE cell antenna [x50]	PARANTCW1TY	B504 and M-SoM	<a href="#">Datasheet</a>

Single quantity M-SoM units and developer kits include a PARANTCW1EA antenna. Tray quantities of the M-SoM do not include antennas.

Dimension	Value	Unit
-----------	-------	------

Length	116.0 mm
Width	27.0 mm
Thickness	0.2 mm
Cable Length	189.5 mm

Parameter	700/850/900	1700/1800/1900	2100	2400	2600	Unit
Peak gain						
PARANTCWIEA	2.8	5.3	5.3	5.3	5.3	dBi

### Certified BLE antenna

The following antenna is optional and can be omitted if you do not wish to use BLE. It can be purchased in the [Particle online store](#).

Antenna	SKU	Links
Particle Wi-Fi Antenna 2.4GHz, [x1]	ANT-FLXV2	<a href="#">Datasheet</a>   <a href="#">Retail Store</a>
Particle Wi-Fi Antenna 2.4GHz, [x50]	ANT-FLXV2-50	<a href="#">Datasheet</a>

General antenna parameters:

Parameter	Value	Unit
Antenna Type	Dipole	
Radiation Properties	Omnidirectional	
Polarization	Vertical	
Impedance	50	ohms
Peak Gain	2.0	dBi
Max VSWR	< 2.0	

Mechanical:

Parameter	Value	Unit
Dimensions	45.1 x 7.4 x 1.0	mm
Material	PCB	
Connector	U.FL (IPEX)	
Cable	Mini-coax 1.13mm	
Cable length	120	mm

Environmental:

Parameter	Value
Operating temperature	-20°C to 75°C
Storage temperature	-20°C to 75°C
ROHS Compliant	✓

### Certified NFC antenna

Antenna	SKU	Links
Particle NFC Antenna, [x1]	ANT-NFC	<a href="#">Datasheet</a>   <a href="#">Retail Store</a>

General antenna parameters:

Parameter	Value	Unit
-----------	-------	------

Frequency	13.56 MHz
Communication Distance (max)	52 mm

Mechanical:

Parameter	Value	Unit
Dimensions	35 x 35	mm
Connector and cable	U.FL and 1.13mm mini coax	
Cable length	100	mm

Environmental:

Parameter	Value
Operating temperature	-20°C to 85°C
Storage temperature	-20°C to 85°C
ROHS Compliant	✓

## CERTIFIED GNSS ANTENNAS

SKU	Description
PARANTGNIEA	Particle GNSS FPC Antenna, [x1] <a href="#">Datasheet</a>
PARANTGNITY	Particle GNSS FPC Antenna, [x50] <a href="#">Datasheet</a>

Single quantity B-SoM units and developer kits include a PARANTGNIEA antenna. Tray quantities of the B-SoM do not include antennas. If not using the GNSS feature, the antenna can be omitted from your design.

- GNSS support will be added in a future version of Device OS.
- Feature such of high-precision, dead-reckoning, and high updates rates will require an external GNSS chip.

## General antenna guidance

- The antenna placement needs to follow some basic rules, as any antenna is sensitive to its environment. Mount the antenna at least 10mm from metal components or surfaces, ideally 20mm for best radiation efficiency, and try to maintain a minimum of three directions free from obstructions to be able to operate effectively.
- Needs tuning with actual product enclosure and all components.
- For the BLE antenna, it is recommended to use a 2.4 GHz single-frequency antenna and not a 2.4 GHz + 5 GHz antenna, so as to avoid large gain at the frequency twice of 2.4 GHz which can cause the second harmonic radiation of 2.4 GHz to exceed standards.

## PERIPHERALS AND GPIO

Peripheral Type	Qty	Input(I) / Output(O)
Digital	24 (max)	I/O
Analog (ADC)	8 (max)	I
UART	1	I/O
SPI	2	I/O
I2C	2	I/O
USB	1	I/O
PWM	8 (max)	O

There are some optional B504 module specific I/O:

- Quectel USB and VBUS (for modem firmware upgrades)
- Quectel Ring Indicator (RI) output

**Note:** All GPIOs are only rated at 3.3VDC max.

## JTAG AND SWD

The B504 module has 4 pads at the bottom exposing the SWD interface of the nRF52840. This interface can be used to debug your code or reprogram your B504 bootloader, device OS, or the user firmware. We use 4 pogo-pins connecting to these pads during production for firmware flashing.

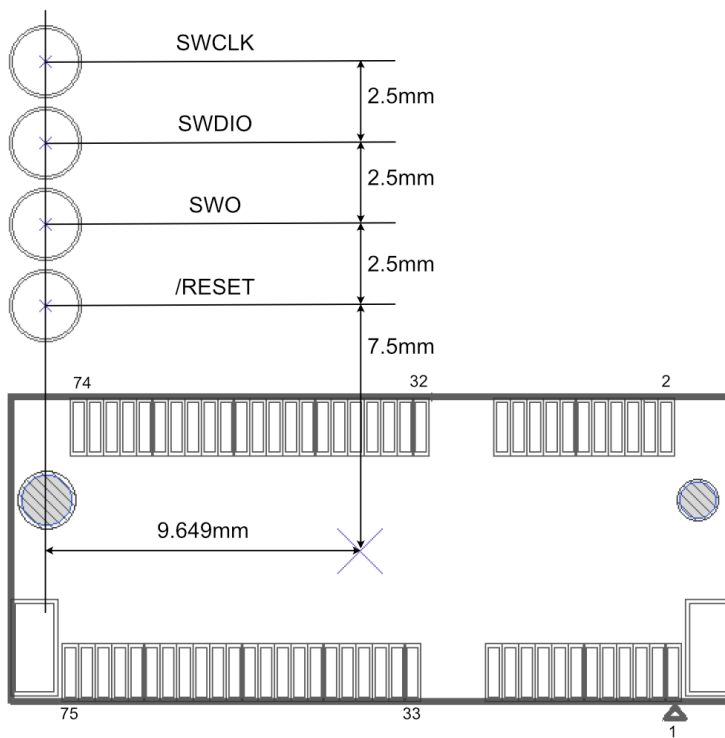

# Memory map

## **NRF52840 FLASH LAYOUT OVERVIEW**

---

- Bootloader (48KB, @0xF4000)
- User Application: 256KB @ 0xB4000
- System (656KB, @0x30000)
- SoftDevice (192KB)

## **EXTERNAL SPI FLASH LAYOUT OVERVIEW (DFU OFFSET: 0X80000000)**

---

- OTA (1500KB, @0x00289000)
- Reserved (420KB, @0x00220000)
- FAC (128KB, @0x00200000)
- LittleFS (2M, @0x00000000)

# Pins and button definitions

## PINOUT DIAGRAM

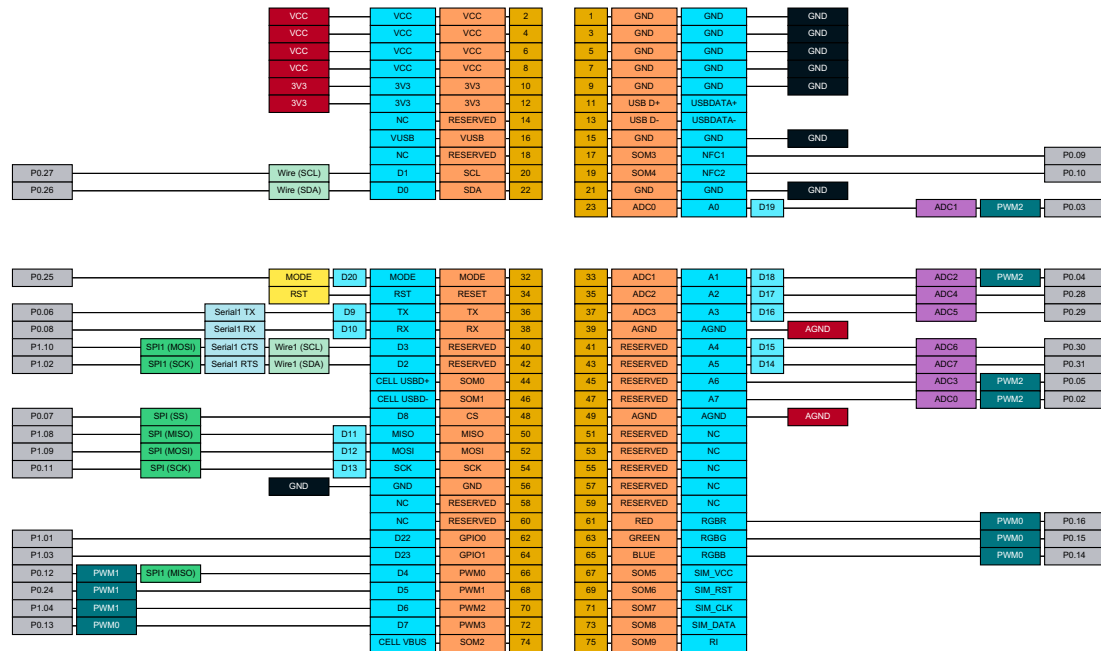

## COMMON SOM PINS

**RESERVED** and **SOM** pins may vary across different SoM models. If you are designing for this specific module, or similar (modules), you can use the indicated functions even if the pin is marked RESERVED. Most nRF52840-based modules will have the same pin functions on the RESERVED pins

Future modules with a different MCU may have different pin functions. An effort will be made to assign all of the listed functions for ADC, PWM, SPI, etc. from the set of common SoM pin functions in future modules, but the functions on RESERVED and SOM pins will likely vary.

## GPIO AND PORT LISTING

Pin Name	Module Pin	MCU
A0 / D19	23	ADC1
A1 / D18	33	ADC2
A2 / D17	35	ADC4
A3 / D16	37	ADC5
A4 / D15	41	ADC6
A5 / D14	43	ADC7
A6	45	ADC3
A7	47	ADC0
CELL USBD-	46	
CELL USBD+	44	
CELL VBUS	74	
D0	22	Wire (SDA)
D1	20	Wire (SCL)
D2	42	Wire1 (SDA) SPI1 (SCK) Serial1 RTS
		P1.02

D3	40	Wire1 (SCL)	SPI1 (MOSI)	Serial1 CTS	P1.01
D4	66		SPI1 (MISO)		P1.08
D5	68				P1.10
D6	70				P1.11
D7	72				P1.12
D8	48		SPI (SS)		P1.03
D22	62				P0.24
D23	64				P1.09
MISO / D11	50		SPI (MISO)		P1.14
MOSI / D12	52		SPI (MOSI)		P1.13
NC	14				
NC	75				
NFC1	17				P0.09
NFC2	19				P0.10
RGBB	65				P0.15
RGBG	63				P0.14
RGBR	61				P0.13
RX / D10	38			Serial1 RX	P0.08
SCK / D13	54		SPI (SCK)		P1.15
SIM_CLK	71				
SIM_DATA	73				
SIM_RST	69				
SIM_VCC	67				
TX / D9	36			Serial1 TX	P0.06
USBDATA-	13				
USBDATA+	11				
VUSB	16				

## ADC (ANALOG TO DIGITAL CONVERTER)

---

The B504 supports 8 ADC inputs.

Pin	Pin Name	Description	Interface	MCU
23	A0 / D19	A0 Analog in, GPIO, PWM	ADC1	P0.03
33	A1 / D18	A1 Analog in, GPIO, PWM	ADC2	P0.04
35	A2 / D17	A2 Analog in, GPIO	ADC4	P0.28
37	A3 / D16	A3 Analog in, GPIO	ADC5	P0.29
41	A4 / D15	A4 Analog in, GPIO	ADC6	P0.30
43	A5 / D14	A5 Analog in, GPIO	ADC7	P0.31
45	A6	A6 Analog in, PWM, GPIO	ADC3	P0.05
47	A7	A7 Analog in, GPIO, Ethernet Reset	ADC0	P0.02

- ADC inputs are single-ended and limited to 0 to 3.3V
- Resolution is 12 bits

## UART SERIAL

---



The B504 supports one UART serial interfaces.

Pin	Pin Name	Description	Interface	MCU
36	TX / D9	Serial TX, GPIO	Serial1 TX	P0.06
38	RX / D10	Serial RX, GPIO	Serial1 RX	P0.08
40	D3	SPI1 MOSI, Serial1 CTS, GPIO, Wire1 SCL	Serial1 CTS	P1.01
42	D2	SPI1 SCK, Serial1 RTS, PWM, GPIO, Wire1 SDA	Serial1 RTS	P1.02

- The UART pins are 3.3V and must not be connected directly to a RS-232C port or to a 5V TTL serial port
- Hardware flow control is optional; if not used then the RTS and CTS pins can be used as regular GPIO
- You cannot use hardware flow control and Ethernet at the same time.

## SPI

---

The B504 supports two SPI (serial peripheral interconnect) ports.

Pin	Pin Name	Description	Interface	MCU
40	D3	SPI1 MOSI, Serial1 CTS, GPIO, Wire1 SCL	SPI1 (MOSI)	P1.01
42	D2	SPI1 SCK, Serial1 RTS, PWM, GPIO, Wire1 SDA	SPI1 (SCK)	P1.02
48	D8	GPIO, SPI SS, Ethernet CS	SPI (SS)	P1.03
50	MISO / D11	SPI MISO, GPIO	SPI (MISO)	P1.14
52	MOSI / D12	SPI MOSI, GPIO	SPI (MOSI)	P1.13
54	SCK / D13	SPI SCK, GPIO	SPI (SCK)	P1.15
66	D4	SPI1 MISO, PWM, GPIO	SPI1 (MISO)	P1.08

- The SPI port is 3.3V and must not be connected directly to devices that drive MISO at 5V
- If not using a SPI port, its pins can be used as GPIO
- Any pins can be used as the SPI chip select
- Multiple devices can generally share a single SPI port
- You cannot use SPI1 and Ethernet at the same time.

## I2C

---

The B504 supports two I2C (two-wire serial interface) ports.

Pin	Pin Name	Description	Interface	MCU
20	D1	I2C SCL, GPIO	Wire (SCL)	P0.27
22	D0	I2C SDA, GPIO	Wire (SDA)	P0.26
40	D3	SPI1 MOSI, Serial1 CTS, GPIO, Wire1 SCL	Wire1 (SCL)	P1.01
42	D2	SPI1 SCK, Serial1 RTS, PWM, GPIO, Wire1 SDA	Wire1 (SDA)	P1.02

- The I2C port is 3.3V and must not be connected directly a 5V I2C bus
- Maximum bus speed is 400 kHz
- External pull-up resistors are recommended for I2C as the internal pull-up is 13K.
- If not using I2C, pins D0 and D1 can be used as GPIO or analog input.
- You cannot use Wire1 and Ethernet at the same time.

## PWM

---

The B504 supports PWM (pulse-width modulation) on the following pins:

Pin	Pin Name	Description	Timer	MCU
23	A0 / D19	A0 Analog in, GPIO, PWM	PWM2	P0.03
33	A1 / D18	A1 Analog in, GPIO, PWM	PWM2	P0.04
45	A6	A6 Analog in, PWM, GPIO	PWM2	P0.05
47	A7	A7 Analog in, GPIO, Ethernet Reset	PWM2	P0.02
66	D4	SPI1 MISO, PWM, GPIO	PWM1	P1.08
68	D5	PWM, GPIO	PWM1	P1.10
70	D6	PWM, GPIO	PWM1	P1.11
72	D7	PWM, GPIO	PWM0	P1.12

- PWM that share the same timer (PWM2 for example) must share the same frequency but can have different duty cycles.
- Pin D7 (PWM0) share a timer with the RGB LED and you should not change its frequency but it can have a different duty cycle.

## USB

---

The B504 supports a USB interface for programming the device and for USB serial (CDC) communications. The module itself does not contain a USB connector; you typically add a micro USB or USB C connector on your base board. It is optional but recommended.

Pin	Pin Name	Description	MCU
11	USBDATA+	USB Data+	
13	USBDATA-	USB Data-	
16	VUSB	USB VUSB power pin	
44	CELL USBD+	Cellular Modem USB Data+	
46	CELL USBD-	Cellular Modem USB Data-	

- The Cellular Modem USB connector is optional, and can be used for firmware updates of the cellular module.

## RGB LED

---

The B504 supports an external common anode RGB LED.

One common LED that meets the requirements is the [Cree CLMVC-FKA-CL1D1L71BB7C3C3](#) which is inexpensive and easily procured. You need to add three current limiting resistors. With this LED, we typically use 1K ohm current limiting resistors. These are much larger than necessary. They make the LED less blinding but still provide sufficient current to light the LEDs. If you want maximum brightness you should use the calculated values - 33 ohm on red, and 66 ohm on green and blue.

A detailed explanation of different color codes of the RGB system LED can be found [here](#).

The use of the RGB LED is optional, however it is highly recommended as troubleshooting the device without the LED is very difficult.

Pin	Pin Name	Description	MCU
61	RGBR	RGB LED Red	P0.13

63	RGBG	RGB LED Green	P0.14
65	RGBB	RGB LED Blue	P0.15

## SETUP AND RESET BUTTON

It is highly recommended that you add MODE (SETUP) and RESET buttons to your base board using momentary switches that connect to GND. These are necessary to change the operating mode of the device, for example to enter listening or DFU mode.

Pin	Pin Name	Description	MCU
32	MODE / D20	MODE button, has internal pull-up	P0.11
34	RST	Hardware reset, active low. External pull-up required.	

The MODE button does not have a hardware pull-up on it, so you must add an external pull-up (2.2K to 10K) to 3V3, or connect it to 3V3 if not using a button.

The RST pin does have an internal weak pull-up, but you may want to add external pull-up on that as well, especially if you use an off-board reset button connected by long wires.

## PIN DESCRIPTION

#	Pin	Common	Function	nRF52	Description
1	GND	GND	POWER		System ground.
2	VCC	VCC <sup>5</sup>	POWER		System power in, connect to the +LiPo or supply a fixed 3.6-4.3v power.
3	GND	GND	POWER		System ground.
4	VCC	VCC	POWER		System power in, connect to the +LiPo or supply a fixed 3.6-4.3v power.
5	GND	GND	POWER		System ground.
6	VCC	VCC	POWER		System power in, connect to the +LiPo or supply a fixed 3.6-4.3v power.
7	GND	GND	POWER		System ground.
8	VCC	VCC	POWER		System power in, connect to the +LiPo or supply a fixed 3.6-4.3v power.
9	GND	GND	POWER		System ground.
10	3V3	3V3	POWER		System power in, supply a fixed 3.0-3.6v power.
11	USB D+	USB D+	IO		Data+ pin of the NRF52840 USB port.
12	3V3	3V3	POWER		System power in, supply a fixed 3.0-3.6v power.
13	USB D-	USB D-	IO		Data- pin of the NRF52840 USB port.
14	NC	RESERVED <sup>3</sup>	NC		Leave unconnected.
15	GND	GND	POWER		System ground.
16	VUSB	VUSB	POWER		System power in, USB detect pin for nRF52840. 5V on this pin enables the USB interface.
17	NFC1	SOM3 <sup>3</sup>	NFC input	P0.09	NFC antenna connection.
18	NC	RESERVED <sup>3</sup>	NC		Leave unconnected.
19	NFC2	SOM4 <sup>3</sup>	NFC input	P0.10	NFC antenna connection.
20	D1	SCL	IO	P0.27	I2C SCL, and digital only GPIO.
21	GND	GND	POWER		System ground.
22	D0	SDA	IO	P0.26	I2C SDA, and digital only GPIO.

23	A0	ADC0	IO	P0.03	Analog input ADC0 <sup>2</sup> , and digital GPIO.
32	MODE	MODE	IO	P0.25	Connected to the MODE button input, and digital only GPIO.
33	A1	ADC1	IO	P0.04	Analog input ADC1 <sup>2</sup> , and digital GPIO.
34	RESET	RESET	I		Active-low reset input.
35	A2	ADC2	IO	P0.28	Analog input ADC2 <sup>2</sup> , and digital GPIO.
36	D9	TX	IO	P0.06	Primarily used as UART TX, but can also be used as a digital GPIO.
37	A3	ADC3	IO	P0.29	Analog input ADC3 <sup>2</sup> , and digital GPIO.
38	D10	RX	IO	P0.08	Primarily used as UART RX, but can also be used as a digital GPIO.
39	AGND	AGND	POWER		System analog ground.
40	D3	RESERVED <sup>3</sup>	IO	P1.10	UART flow control CTS, SCL1 (Wire1), SPI1 MOSI, digital only GPIO.
41	A4	RESERVED <sup>3</sup>	IO	P0.30	Analog input ADC4 <sup>2</sup> , and digital GPIO.
42	D2	RESERVED <sup>3</sup>	IO	P1.02	UART flow control RTS, SDA1 (Wire1), SPI1 SCK, digital only GPIO.
43	A5	RESERVED <sup>3</sup>	IO	P0.31	Analog input ADC5 <sup>2</sup> , and digital GPIO.
44	Quectel USB D+	SOM0	IO		Data+ pin of the cellular modem USB port.
45	A6	RESERVED <sup>3</sup>	IO	P0.05	Analog input ADC6 <sup>2</sup> , and digital GPIO.
46	Quectel USB D-	SOM1	IO		Data- pin of the cellular modem USB port.
47	A7	RESERVED <sup>3</sup>	IO	P0.02	Analog input ADC7 <sup>2</sup> , and digital GPIO.
48	D8	CS	IO	P0.07	SPI interface CS, and digital only GPIO.
49	AGND	AGND	POWER		System analog ground.
50	D11	MISO	IO	P1.08	SPI interface MISO, and digital only GPIO.
51	NC	RESERVED <sup>3</sup>	NC		Leave unconnected.
52	D12	MOSI	IO	P1.09	SPI interface MOSI, and digital only GPIO.
53	NC	RESERVED <sup>3</sup>	NC		Leave unconnected.
54	D13	SCK	IO	P0.11	SPI interface SCK, and digital only GPIO.
55	NC	RESERVED <sup>3</sup>	NC		Leave unconnected.
56	GND	GND	POWER		System analog ground.
57	NC	RESERVED <sup>3</sup>	NC		Leave unconnected.
58	NC	RESERVED <sup>3</sup>	NC		Leave unconnected.
59	NC	RESERVED <sup>3</sup>	NC		Leave unconnected.
60	NC	RESERVED <sup>3</sup>	NC		Leave unconnected.
61	RGBR	RED	IO	P0.16	Red pin of the RGB LED.
62	D22	GPIO0	IO	P1.01	GPIO0, digital only.
63	RGBG	GREEN	IO	P0.15	Green pin of the RGB LED.
64	D23	GPIO1	IO	P1.03	GPIO1, digital only.
65	RGBB	BLUE	IO	P0.14	Blue pin of the RGB LED.
66	D4	PWM0	IO	P0.12	SPI1 MISO, Digital only GPIO, and PWM0.
67	SIM_VCC <sup>1</sup>	SOM5 <sup>3</sup>	POWER		Leave unconnected, 1.8V/3V SIM Supply Output from cellular modem.
68	D5	PWM1	IO	P0.24	Digital only GPIO, and PWM1.
69	SIM_RST <sup>1</sup>	SOM6 <sup>3</sup>	IO		Leave unconnected, 1.8V/3V SIM Reset Output from cellular modem.

70	D6	PWM2	IO	P1.04	Digital only GPIO, and PWM2.
71	SIM_CLK <sup>1</sup>	SOM7 <sup>3</sup>	IO		Leave unconnected, 1.8V/3V SIM Clock Output from cellular modem.
72	D7	PWM3	IO	P0.13	Digital only GPIO, and PWM3.
73	SIM_DATA <sup>1</sup>	SOM8 <sup>3</sup>	IO		Leave unconnected, 1.8V/3V SIM Data I/O of cellular modem with internal 4.7 k pull-up.
74	Quectel VBUS	SOM2 <sup>3</sup>	IO		USB detect pin for cellular modem. 5V on this pin enables the Quectel USB interface.
75	Quectel RI	SOM9 <sup>4</sup>	IO		Ring indicator

<sup>1</sup>These pins are connected to the internal MFF2 SIM and should be left open.

<sup>2</sup>A0-A7 are 12-bit Analog-to-Digital (A/D) inputs (0-4095).

<sup>3</sup>SoM-specific and Reserved pins will vary depending on module. They are able to be used on the B523, but their function may be different on future modules.

<sup>4</sup>RI is available on the B504 (Quectel) but not on the B402 (u-blox LTE M1)

<sup>5</sup>The VCC maximum is 4.3V on the B504 (Quectel) but is 4.2V on the B402 (u-blox LTE M1). For compatibility across modules, limit this to 4.2V.

By default, the Tinker application firmware enables the use of the bq24195 PMIC and MAX17043 fuel gauge. This in turn uses I2C (D0 and D1) and pin A6 (PM\_INT). If you are not using the PMIC and fuel gauge and wish to use these pins for other purposes, be sure to disable system power configuration. This setting is persistent, so you may want to disable it with your manufacturing firmware only.

```
System.setPowerConfiguration(SystemPowerConfiguration());
```

If you are using Ethernet with the B-Series SoM, the following pins are used by Ethernet:

Device OS Pin	M.2 Pin	Ethernet Pin
MISO	50	SPI MISO
MOSI	52	SPI MOSI
SCK	54	SPI SCK
A7	47	nRESET
D22	62	nINTERRUPT
D8	48	nCHIP SELECT

## COMPLETE MODULE PIN DETAILS

[Click this link to skip over this section](#)

### 1 GND

#### Details

Pin Number	1
Pin Name	GND
Description	Ground.

### 2 VCC

#### Details

---

Pin Number	2
Pin Name	VCC
Description	System power in, connect to the +LiPo or supply a fixed 3.6-4.2v power.

---

### 3 GND

#### Details

---

Pin Number	3
Pin Name	GND
Description	Ground.

---

### 4 VCC

#### Details

---

Pin Number	4
Pin Name	VCC
Description	System power in, connect to the +LiPo or supply a fixed 3.6-4.2v power.

---

### 5 GND

#### Details

---

Pin Number	5
Pin Name	GND
Description	Ground.

---

### 6 VCC

#### Details

---

Pin Number	6
Pin Name	VCC
Description	System power in, connect to the +LiPo or supply a fixed 3.6-4.2v power.

---

### 7 GND

#### Details

---

Pin Number	7
Pin Name	GND
Description	Ground.

---

### 8 VCC

#### Details

---

Pin Number	8
Pin Name	VCC
Description	System power in, connect to the +LiPo or supply a fixed 3.6-4.2v power.

---

### 9 GND

#### Details

---

Pin Number	9
Pin Name	GND

---

---

Description Ground.

### 10 3V3

#### Details

---

Pin Number	10
Pin Name	3V3
Description	System power in, supply a fixed 3.0-3.6v power.

### 11 USBDATA+

#### Details

---

Pin Number	11
Pin Name	USBDATA+
Description	USB Data+
Input is 5V Tolerant	Yes

### 12 3V3

#### Details

---

Pin Number	12
Pin Name	3V3
Description	System power in, supply a fixed 3.0-3.6v power.

### 13 USBDATA-

#### Details

---

Pin Number	13
Pin Name	USBDATA-
Description	USB Data-
Input is 5V Tolerant	Yes

### 14 NC

#### Details

---

Pin Number	14
Pin Name	NC

### 15 GND

#### Details

---

Pin Number	15
Pin Name	GND
Description	Ground.

### 16 VUSB

#### Details

---

Pin Number	16
Pin Name	VUSB
Description	USB VUSB power pin
Input is 5V Tolerant	Yes

## 17 NFC1

### Details

Pin Number	17
Pin Name	NFC1
Description	NFC Antenna 1
MCU Pin	P0.09

## 18 NC

### Details

Pin Number	18
Pin Name	NC

## 19 NFC2

### Details

Pin Number	19
Pin Name	NFC2
Description	NFC Antenna 2
MCU Pin	P0.10

## 20 D1

### Details

Pin Number	20
Pin Name	D1
Description	I2C SCL, GPIO
Supports digitalRead	Yes
Supports digitalWrite	Yes
I2C interface	SCL. Use Wire object.
Supports attachInterrupt	Yes. You can only have 8 active interrupt pins.
Internal pull resistance	13K
MCU Pin	P0.27

## 21 GND

### Details

Pin Number	21
Pin Name	GND
Description	Ground.

## 22 D0

### Details

Pin Number	22
Pin Name	D0
Description	I2C SDA, GPIO
Supports digitalRead	Yes
Supports digitalWrite	Yes
I2C interface	SDA. Use Wire object.



Supports attachInterrupt	Yes. You can only have 8 active interrupt pins.
Internal pull resistance	13K
MCU Pin	P0.26

### 23 A0

#### Details

Pin Number	23
Pin Name	A0
Pin Alternate Name	D19
Description	A0 Analog in, GPIO, PWM
Supports digitalRead	Yes
Supports digitalWrite	Yes
Supports analogRead	Yes
Supports analogWrite (PWM)	Yes
Supports tone	A0, A1, A6, and A7 must have the same frequency.
Supports attachInterrupt	Yes. You can only have 8 active interrupt pins.
Internal pull resistance	13K
MCU Pin	P0.03

### 32 MODE

#### Details

Pin Number	32
Pin Name	MODE
Pin Alternate Name	D20
Description	MODE button, has internal pull-up
MCU Pin	P0.25

### 33 A1

#### Details

Pin Number	33
Pin Name	A1
Pin Alternate Name	D18
Description	A1 Analog in, GPIO, PWM
Supports digitalRead	Yes
Supports digitalWrite	Yes
Supports analogRead	Yes
Supports analogWrite (PWM)	Yes
Supports tone	A0, A1, A6, and A7 must have the same frequency.
Supports attachInterrupt	Yes. You can only have 8 active interrupt pins.
Internal pull resistance	13K
MCU Pin	P0.04

### 34 RST

#### Details

Pin Number 34

Pin Name	RST
Description	Hardware reset, active low. External pull-up required.

### 35 A2

#### Details

Pin Number	35
Pin Name	A2
Pin Alternate Name	D17
Description	A2 Analog in, GPIO
Supports digitalRead	Yes
Supports digitalWrite	Yes
Supports analogRead	Yes
Supports attachInterrupt	Yes. You can only have 8 active interrupt pins.
Internal pull resistance	13K
MCU Pin	P0.28

### 36 TX

#### Details

Pin Number	36
Pin Name	TX
Pin Alternate Name	D9
Description	Serial TX, GPIO
Supports digitalRead	Yes
Supports digitalWrite	Yes
UART serial	TX. Use Serial1 object.
Supports attachInterrupt	Yes. You can only have 8 active interrupt pins.
Internal pull resistance	13K
MCU Pin	P0.06

### 37 A3

#### Details

Pin Number	37
Pin Name	A3
Pin Alternate Name	D16
Description	A3 Analog in, GPIO
Supports digitalRead	Yes
Supports digitalWrite	Yes
Supports analogRead	Yes
Supports attachInterrupt	Yes. You can only have 8 active interrupt pins.
Internal pull resistance	13K
MCU Pin	P0.29

### 38 RX

#### Details

Pin Number	38
------------	----

Pin Name	RX
Pin Alternate Name	D10
Description	Serial RX, GPIO
Supports digitalRead	Yes
Supports digitalWrite	Yes
UART serial	RX. Use Serial1 object.
Supports attachInterrupt	Yes. You can only have 8 active interrupt pins.
Internal pull resistance	13K
MCU Pin	P0.08

### 39 AGND

#### Details

Pin Number	39
Pin Name	AGND
Description	Analog Ground.

### 40 D3

#### Details

Pin Number	40
Pin Name	D3
Description	SPI1 MOSI, Serial1 CTS, GPIO, Wire1 SCL
Supports digitalRead	Yes
Supports digitalWrite	Yes
UART serial	CTS. Use Serial1 object.
SPI interface	MOSI. Use SPI1 object.
I2C interface	SCL. Use Wire1 object.
Supports attachInterrupt	Yes. You can only have 8 active interrupt pins.
Internal pull resistance	13K
MCU Pin	P1.10

### 41 A4

#### Details

Pin Number	41
Pin Name	A4
Pin Alternate Name	D15
Description	A4 Analog in, GPIO
Supports digitalRead	Yes
Supports digitalWrite	Yes
Supports analogRead	Yes
Supports attachInterrupt	Yes. You can only have 8 active interrupt pins.
Internal pull resistance	13K
MCU Pin	P0.30

### 42 D2

#### Details

Pin Number	42
------------	----

Pin Number	42
Pin Name	D2
Description	SPI1 SCK, Serial11 RTS, PWM, GPIO, Wire1 SDA
Supports digitalRead	Yes
Supports digitalWrite	Yes
UART serial	RTS. Use Serial11 object.
SPI interface	SCK. Use SPI11 object.
I2C interface	SDA. Use Wire1 object.
Supports attachInterrupt	Yes. You can only have 8 active interrupt pins.
Internal pull resistance	13K
MCU Pin	P1.02

### 43 A5

#### Details

Pin Number	43
Pin Name	A5
Pin Alternate Name	D14
Description	A5 Analog in, GPIO
Supports digitalRead	Yes
Supports digitalWrite	Yes
Supports analogRead	Yes
Supports attachInterrupt	Yes. You can only have 8 active interrupt pins.
Internal pull resistance	13K
MCU Pin	P0.31

### 44 CELL USBD+

#### Details

Pin Number	44
Pin Name	CELL USBD+
Description	Cellular Modem USB Data+
Input is 5V Tolerant	Yes

### 45 A6

#### Details

Pin Number	45
Pin Name	A6
Description	A6 Analog in, PWM, GPIO
Supports digitalRead	Yes
Supports digitalWrite	Yes
Supports analogRead	Yes
Supports analogWrite (PWM)	Yes
Supports tone	A0, A1, A6, and A7 must have the same frequency.
Supports attachInterrupt	Yes. You can only have 8 active interrupt pins.
Internal pull resistance	13K
MCU Pin	P0.05

## 46 CELL USBD-

### Details

Pin Number	46
Pin Name	CELL USBD-
Description	Cellular Modem USB Data-
Input is 5V Tolerant	Yes

## 47 A7

### Details

Pin Number	47
Pin Name	A7
Description	A7 Analog in, GPIO, Ethernet Reset
Supports digitalRead	Yes
Supports digitalWrite	Yes
Supports analogRead	Yes
Supports analogWrite (PWM)	Yes
Supports tone	A0, A1, A6, and A7 must have the same frequency.
Supports attachInterrupt	Yes. You can only have 8 active interrupt pins.
Internal pull resistance	13K
MCU Pin	P0.02

## 48 D8

### Details

Pin Number	48
Pin Name	D8
Description	GPIO, SPI SS, Ethernet CS
Supports digitalRead	Yes
Supports digitalWrite	Yes
SPI interface	SS. Use SPI object. This is only the default SS/CS pin, you can use any GPIO instead.
Supports attachInterrupt	Yes. You can only have 8 active interrupt pins.
Internal pull resistance	13K
MCU Pin	P0.07

## 49 AGND

### Details

Pin Number	49
Pin Name	AGND
Description	Analog Ground.

## 50 MISO

### Details

Pin Number	50
Pin Name	MISO
Pin Alternate Name	D11
Description	SPI MISO, GPIO

Supports digitalRead	Yes
Supports digitalWrite	Yes
SPI interface	MISO. Use SPI object.
Supports attachInterrupt	Yes. You can only have 8 active interrupt pins.
Internal pull resistance	13K
MCU Pin	P1.08

## 51 NC

### Details

Pin Number	51
Pin Name	NC

## 52 MOSI

### Details

Pin Number	52
Pin Name	MOSI
Pin Alternate Name	D12
Description	SPI MOSI, GPIO
Supports digitalRead	Yes
Supports digitalWrite	Yes
SPI interface	MOSI. Use SPI object.
Supports attachInterrupt	Yes. You can only have 8 active interrupt pins.
Internal pull resistance	13K
MCU Pin	P1.09

## 53 NC

### Details

Pin Number	53
Pin Name	NC

## 54 SCK

### Details

Pin Number	54
Pin Name	SCK
Pin Alternate Name	D13
Description	SPI SCK, GPIO
Supports digitalRead	Yes
Supports digitalWrite	Yes
SPI interface	SCK. Use SPI object.
Supports attachInterrupt	Yes. You can only have 8 active interrupt pins.
Internal pull resistance	13K
MCU Pin	P0.11

## 55 NC

### Details

Pin Number	55
Pin Name	NC

### 56 GND

#### Details

Pin Number	56
Pin Name	GND
Description	Ground.

### 57 NC

#### Details

Pin Number	57
Pin Name	NC

### 58 NC

#### Details

Pin Number	58
Pin Name	NC

### 59 NC

#### Details

Pin Number	59
Pin Name	NC

### 60 NC

#### Details

Pin Number	60
Pin Name	NC

### 61 RGBR

#### Details

Pin Number	61
Pin Name	RGBR
Description	RGB LED Red
MCU Pin	P0.16

### 62 D22

#### Details

Pin Number	62
Pin Name	D22
Description	GPIO, Ethernet INT
Supports digitalRead	Yes
Supports digitalWrite	Yes
Supports attachInterrupt	Yes. You can only have 8 active interrupt pins.
Internal pull resistance	13K

---

MCU Pin	P1.01
---------	-------

### 63 RGBG

#### Details

---

Pin Number	63
Pin Name	RGBG
Description	RGB LED Green
MCU Pin	P0.15

### 64 D23

#### Details

---

Pin Number	64
Pin Name	D23
Description	GPIO
Supports digitalRead	Yes
Supports digitalWrite	Yes
Supports attachInterrupt	Yes. You can only have 8 active interrupt pins.
Internal pull resistance	13K
MCU Pin	P1.03

### 65 RGBB

#### Details

---

Pin Number	65
Pin Name	RGBB
Description	RGB LED Blue
MCU Pin	P0.14

### 66 D4

#### Details

---

Pin Number	66
Pin Name	D4
Description	SPI1 MISO, PWM, GPIO
Supports digitalRead	Yes
Supports digitalWrite	Yes
Supports analogWrite (PWM)	Yes
Supports tone	D4, D5, and D6 must have the same frequency.
SPI interface	MISO. Use SPI1 object.
Supports attachInterrupt	Yes. You can only have 8 active interrupt pins.
Internal pull resistance	13K
MCU Pin	P0.12

### 67 SIM\_VCC

#### Details

---

Pin Number	67
Pin Name	SIM_VCC



---

Description Leave unconnected, 1.8V/3V SIM Supply Output from R410M.

## 68 D5

### Details

---

Pin Number	68
Pin Name	D5
Description	PWM, GPIO
Supports digitalRead	Yes
Supports digitalWrite	Yes
Supports analogWrite (PWM)	Yes
Supports tone	D4, D5, and D6 must have the same frequency.
Supports attachInterrupt	Yes. You can only have 8 active interrupt pins.
Internal pull resistance	13K
MCU Pin	P0.24

## 69 SIM\_RST

### Details

---

Pin Number	69
Pin Name	SIM_RST
Description	Leave unconnected, 1.8V/3V SIM Reset Output from R410M.

## 70 D6

### Details

---

Pin Number	70
Pin Name	D6
Description	PWM, GPIO
Supports digitalRead	Yes
Supports digitalWrite	Yes
Supports analogWrite (PWM)	Yes
Supports tone	D4, D5, and D6 must have the same frequency.
Supports attachInterrupt	Yes. You can only have 8 active interrupt pins.
Internal pull resistance	13K
MCU Pin	P1.04

## 71 SIM\_CLK

### Details

---

Pin Number	71
Pin Name	SIM_CLK
Description	Leave unconnected, 1.8V/3V SIM Clock Output from R410M.

## 72 D7

### Details

---

Pin Number	72
Pin Name	D7
Description	PWM, GPIO

Supports digitalRead	Yes
Supports digitalWrite	Yes
Supports analogWrite (PWM)	PWM is shared with the RGB LED, you can specify a different duty cycle but should not change the frequency.
Supports attachInterrupt	Yes. You can only have 8 active interrupt pins.
Internal pull resistance	13K
MCU Pin	P0.13

### 73 SIM\_DATA

#### Details

Pin Number	73
Pin Name	SIM_DATA
Description	Leave unconnected, 1.8V/3V SIM Data I/O of R410m with internal 4.7 k pull-up.

### 74 CELL\_VBUS

#### Details

Pin Number	74
Pin Name	CELL_VBUS
Description	USB detect pin for R410M. 5V on this pin enables the Cellular Modem USB interface.
Input is 5V Tolerant	Yes

### 75 RI

#### Details

Pin Number	75
Pin Name	RI
Description	Ring Indicator for cellular modem

### LED STATUS

#### System RGB LED

Unlike the Boron, the B504 module does not have an on-module RGB system status LED. We have provided its individual control pins for you to connect an LED of your liking. This will allow greater flexibility in the end design of your products.

A detailed explanation of different color codes of the RGB system LED can be found [here](#).

### PMIC NOTES

When using the B-Series SoM with a bq24195 PMIC, note the following:

By default, the bq24195 sets the input current limit, which affects powering by VIN and VUSB, to 100 mA. This affects the VSYS output of the PMIC, which powers both the cellular modem and 3V3 supply, and is not enough to power the B-Series SoM in normal operation.

If your device has the default firmware (Tinker), it will attempt to connect to the cloud, brown out due to insufficient current, then the device will reset. This may result in what appears to be the status LED blinking white, but is actually rolling reboot caused by brownout.

A factory new B-Series SoM does not enable the PMIC setup. To enable the use of the bq21415, you

must enable the system power feature [PMIC\\_DETECTION](#) in your code. This defaults to off because the B-Series SoM can be used without a PMIC, or with a different PMIC, and also requires I2C on D0/D1, and some base boards may use those pins as GPIO.

Because the input current limit does not affect the battery input (Li+), for troubleshooting purposes it can be helpful to attach a battery to help rule out input current limit issues. It's also possible to supply 3.7V via a bench power supply to the battery input, instead of VIN.

The input current limit can result in a situation where you can't bring up a B-Series SoM because it browns out continuously, but also cannot flash code to it to stop it from browning out. There are two general solutions:

- Attach a battery or supply by Li+ when bringing up a board.
- Use SWD/JTAG and reset halt the MCU. This will prevent it from connecting to the cloud, so you can flash Device OS and firmware to it by SWD.

The input current limit is actually controlled by three factors:

- The [power source max current setting](#) in the PMIC. The default is 900 mA. It can be set to 100, 150, 500, 900, 1200, 1500, 2000, or 3000 mA.
- It is also limited by the hardware ILIM resistor. On Particle devices with a built-in PMIC, this is set to 1590 mA, but if you are implementing your own PMIC hardware, you can adjust this higher.
- When connected by USB, it will use DPDM, current negotiation via the USB DP (D+) and DM (D-) lines.

Note that some 2A tablet chargers and multi-port USB power supplies supply 2A but do not implement DPDM; these will be treated as if VIN was used, and you must set the power source current, otherwise the input current will be limited to 900 mA, which is not enough to power a 2G/3G cellular modem without an attached battery.

# Technical specifications

## ABSOLUTE MAXIMUM RATINGS <sup>[1]</sup>

---

### Supply voltages

Parameter	Symbol	Min	Typ	Max	Unit
<b>Supply voltages</b>					
Supply Input Voltage	VCC	-0.3		+6.0	V
Supply Input Voltage	3V3	-0.3		+3.9	V
VBUS USB supply voltage	VUSB	-0.3		+5.8	V
<b>I/O pin voltage</b>					
VI/O, VDD ≤ 3.6 V	IO	-0.3		VDD + 0.3	V
VI/O, VDD > 3.6 V	IO	-0.3		+3.9	V
<b>NFC antenna pin current</b>					
I <sub>NFC1/2</sub>	NFC1/NFC2			80	mA
<b>Radio</b>					
BT RF input level (52840)				10	dBm
<b>Environmental</b>					
Storage temperature		-40		+85	°C

<sup>[1]</sup> Stresses beyond those listed under absolute maximum ratings may cause permanent damage to the device. These are stress ratings only, and functional operation of the device at these or any other conditions beyond those indicated under recommended operating conditions is not implied. Exposure to absolute-maximum-rated conditions for extended periods may affect device reliability.

## RECOMMENDED OPERATING CONDITIONS

---

Parameter	Symbol	Min	Typ	Max	Unit
<b>Supply voltages</b>					
Supply Input Voltage	VCC	+3.6	+3.8	+4.2	V
Supply Input Voltage	3V3	+3.0	+3.3	+3.6	V
VBUS USB supply voltage	VUSB	+4.35	+5.0	+5.5	V
<b>Environmental</b>					
Normal operating temperature <sup>1</sup>		-20	+25	+65	°C
Extended operating temperature <sup>2</sup>		-40		+85	°C
Humidity Range Non condensing, relative humidity				95	%

### Notes:

<sup>1</sup> Normal operating temperature range (fully functional and meet 3GPP specifications).

<sup>2</sup> Extended operating temperature range (RF performance may be affected outside normal operating range, though module is fully functional)

## POWER CONSUMPTION

Values are from B523 using the EG91-E cellular modem. Actual operating current with cellular using the EG91-NAX modem may vary slightly but should be similar.

### These values are preliminary and subject to change

Parameter	Symbol	Min	Typ	Peak	Unit
Operating Current (uC on, peripherals and radio disabled)	I <sub>idle</sub>	4.47	4.48	4.51	mA
Operating Current (uC on, cellular on but not connected)	I <sub>cell_idle</sub>	17.5	34.2	744	mA
Operating Current (uC on, cellular connecting to tower)	I <sub>cell_conn_twr</sub>	17.9	72.3	711	mA
Operating Current (uC on, cellular connecting to cloud)	I <sub>cell_conn_cloud</sub>	23.0	93.6	669	mA
Operating Current (uC on, cellular connected but idle)	I <sub>cell_cloud_idle</sub>	22.9	26.8	149	mA
Operating Current (uC on, cellular connected and transmitting)	I <sub>cell_cloud_tx</sub>	113	139	519	mA
STOP mode sleep, GPIO wake-up	I <sub>stop_gpio</sub>	323	538	916	uA
STOP mode sleep, analog wake-up	I <sub>stop_analog</sub>	272	537	948	uA
STOP mode sleep, RTC wake-up	I <sub>stop_intrtc</sub>	264	537	947	uA
STOP mode sleep, BLE wake-up, advertising	I <sub>stop_ble_adv</sub>		604	2260	uA
STOP mode sleep, BLE wake-up, connected	I <sub>stop_ble_conn</sub>		619	1700	uA
STOP mode sleep, serial wake-up	I <sub>stop_usart</sub>	327	537	912	uA
STOP mode sleep, cellular wake-up	I <sub>stop_cell</sub>	18.7	23.1	140	mA
ULP mode sleep, GPIO wake-up	I <sub>ulp_gpio</sub>		53.6	446	uA
ULP mode sleep, analog wake-up	I <sub>ulp_analog</sub>		55.8	420	uA
ULP mode sleep, RTC wake-up	I <sub>ulp_intrtc</sub>		54.8	444	uA
ULP mode sleep, BLE wake-up, advertising	I <sub>ulp_ble_adv</sub>		139	2430	uA
ULP mode sleep, BLE wake-up, connected	I <sub>ulp_ble_conn</sub>		162	1090	uA
ULP mode sleep, serial wake-up	I <sub>ulp_usart</sub>	317	537	938	uA
ULP mode sleep, cellular wake-up	I <sub>ulp_cell</sub>	18.4	22.8	149	mA
HIBERNATE mode sleep, GPIO wake-up	I <sub>hib_gpio</sub>		29.7	430	uA
HIBERNATE mode sleep, analog wake-up	I <sub>hib_analog</sub>		30.8	441	uA

<sup>1</sup>The min, and particularly peak, values may consist of very short transients. The typical (typ) values are the best indicator of overall power consumption over time. The peak values indicate the absolute minimum capacity of the power supply necessary, not overall consumption.

## RADIO SPECIFICATIONS

---

The B-Series SoM has two radio modules.

### Nordic Semiconductor nRF52840 for BLE

Feature	Description
Feature	Bluetooth LE 5
Operating Frequencies	2360 to 2500 MHz
Output Power	Programmable -20dBm to +8dBm
PLL channel spacing	1 MHz
On the air data rate	125 to 2000 kbps

### Nordic Semiconductor nRF52840 for NFC tag

Feature	Description
Feature	NFC Tag-A
Frequency	13.56 MHz

### Quectel EG91-NAX

Parameter	Value
Protocol stack	3GPP Release 13
RAT	LTE Cat 1
LTE FDD Bands	Band 12 (700 MHz)
	Band 13 (750 MHz)
	Band 5 (850 MHz)
	Band 26 (850 MHz)
	Band 4 (1700 MHz)
	Band 2 (1900 MHz)
	Band 25 (1900 MHz)
WCDMA Bands	Band 5 (850 MHz)
	Band 4 (1700)
	Band 2 (1900)
Power class	Class 3 (24dBm $\pm$ 3dB) for WCDMA bands
	Class 3 (23dBm $\pm$ 2dB) for LTE FDD bands

## I/O CHARACTERISTICS

These specifications are based on the nRF52840 datasheet.

Symbol	Parameter	Min	Typ	Max	Unit
VIH	Input high voltage	0.7 xVDD		VDD	V
VIL	Input low voltage	VSS		0.3 xVDD	V
VOH,SD	Output high voltage, standard drive, 0.5 mA, VDD ≥1.7	VDD - 0.4		VDD	V
VOH,HDH	Output high voltage, high drive, 5 mA, VDD ≥ 2.7 V	VDD - 0.4		VDD	V
VOH,HDL	Output high voltage, high drive, 3 mA, VDD ≥ 1.7 V	VDD - 0.4		VDD	V
VOL,SD	Output low voltage, standard drive, 0.5 mA, VDD ≥1.7	VSS		VSS + 0.4	V
VOL,HDH	Output low voltage, high drive, 5 mA, VDD ≥ 2.7 V	VSS		VSS + 0.4	V
VOL,HDL	Output low voltage, high drive, 3 mA, VDD ≥ 1.7 V	VSS		VSS + 0.4	V
IOL,SD	Current at VSS+0.4 V, output set low, standard drive, VDD ≥1.7	1	2	4	mA
IOL,HDH	Current at VSS+0.4 V, output set low, high drive, VDD ≥ 2.7V	6	10	15	mA
IOL,HDL	Current at VSS+0.4 V, output set low, high drive, VDD ≥ 1.7V	3			mA
IOH,SD	Current at VDD-0.4 V, output set high, standard drive, VDD ≥1.7	1	2	4	mA
IOH,HDH	Current at VDD-0.4 V, output set high, high drive, VDD ≥ 2.7V	6	9	14	mA
IOH,HDL	Current at VDD-0.4 V, output set high, high drive, VDD ≥ 1.7V	3			mA
tRF,15pF	Rise/fall time, standard drivemode, 10-90%, 15 pF load <sup>1</sup>		9		ns
tRF,25pF	Rise/fall time, standard drive mode, 10-90%, 25 pF load <sup>1</sup>		13		ns
tRF,50pF	Rise/fall time, standard drive mode, 10-90%, 50 pF load <sup>1</sup>		25		ns
tHRF,15pF	Rise/Fall time, high drive mode, 10-90%, 15 pF load <sup>1</sup>		4		ns
tHRF,25pF	Rise/Fall time, high drive mode, 10-90%, 25 pF load <sup>1</sup>		5		ns
tHRF,50pF	Rise/Fall time, high drive mode, 10-90%, 50 pF load <sup>1</sup>		8		ns
RPU	Pull-up resistance	11	13	16	kΩ
RPD	Pull-down resistance	11	13	16	kΩ
CPAD	Pad capacitance		3		pF
CPAD_NFC	Pad capacitance on NFC pads		4		pF
INFC_LEAK	Leakage current between NFC pads when driven to different states		1	10	μA

- Rise and fall times based on simulations
- GPIO default to standard drive (2mA) but can be reconfigured to high drive (9mA) in Device OS 2.0.0 and later using the `pinSetDriveStrength()` function.

# Mechanical specifications

## DIMENSIONS AND WEIGHT

---

Parameters	Value	Unit
Width	30	mm
Height	42	mm
Thickness	5.5	mm
Weight	6.2	grams

## 3D MODELS

---

3D models of the B-Series SoM module are available in the [hardware-libraries Github](#) in formats including step, iges, stl, and f3d.

The 3D models are the same for the B504 and B523 as the cellular modem module is the same size.

## MECHANICAL DRAWING

---

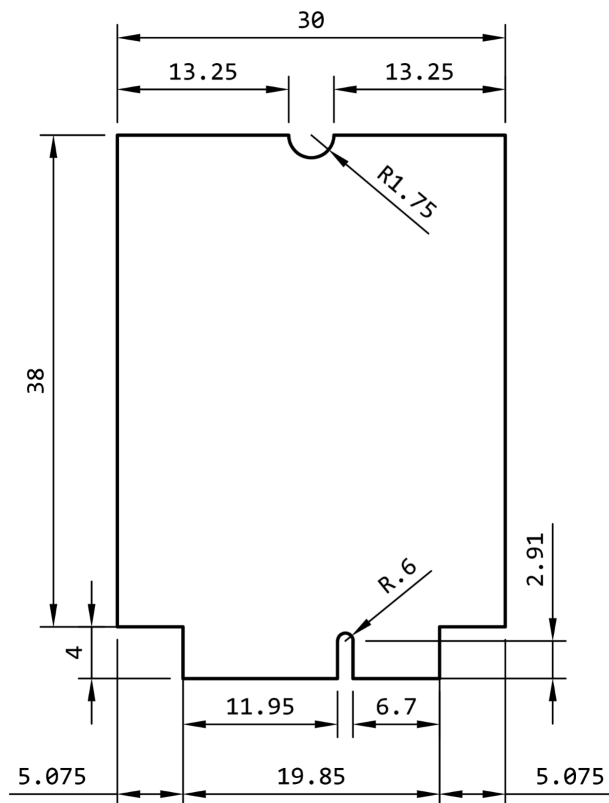

Dimensions are in millimeters.



**MATING CONNECTOR AND LAND PATTERN**

The mating connector is a an M.2 (NGFF) type 4. Note that there are several different key configurations for the M.2, and type 4 is different than is commonly used on SSDs.

One compatible connector is the [TE 2199230-4](#). It is widely available including at suppliers such as [DigiKey](#).

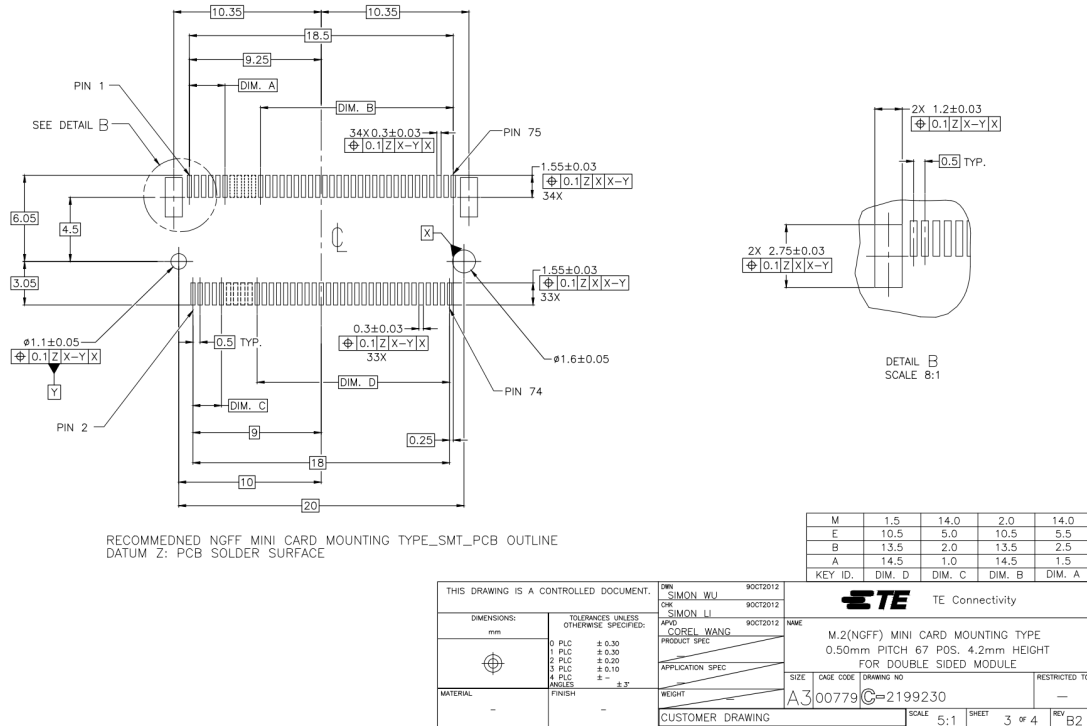

## SCREW ASSEMBLY

---

The M.2 SoM requires a screw to hold the SoM in place because the M.2 connector does not have integrated locks and the SoM will pop up if not attached to the base board. The screw also provides better vibration resistance than locking clips.

- This is one style of standoff.

### 宝贝实拍 PRODUCT PHOTOS



### 图纸参数 Drawing parameter

#### NGFF M.2 4.2H高配套铜柱

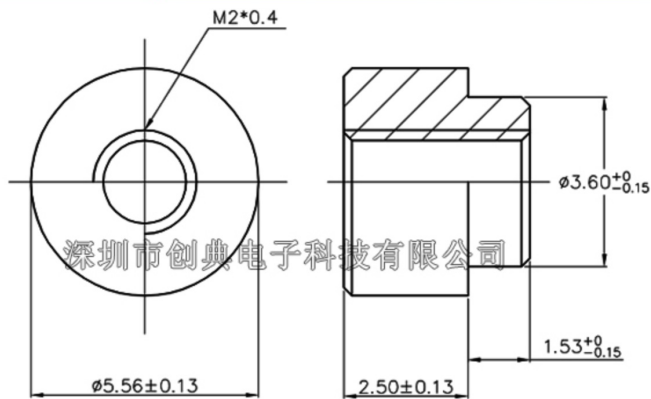

- An [alternative design](#) uses a [JAE SM3ZS067U410-NUT1-R1200](#) standoff. It's reflow soldered to your base board and has a threaded hole for a M2\*3 screw to hold down the SoM. This may be easier to obtain.
- The screw should be connected to the ground plane on your base board.

## DESIGN CONSIDERATIONS

---

We strongly recommend against placing components under the SOM board because there is not enough height.

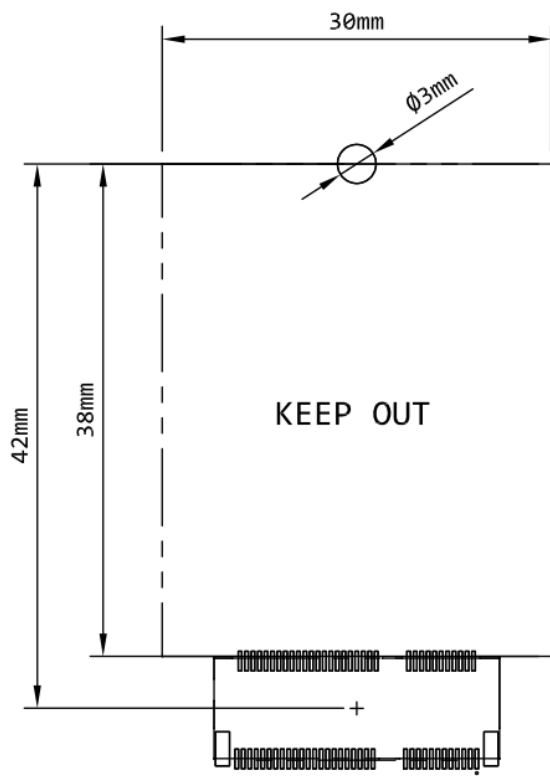

# Product handling

## **ESD PRECAUTIONS**

---

The B series contains highly sensitive electronic circuitry and is an Electrostatic Sensitive Device (ESD). Handling an B series without proper ESD protection may destroy or damage it permanently. Proper ESD handling and packaging procedures must be applied throughout the processing, handling and operation of any application that incorporates the B series module. ESD precautions should be implemented on the application board where the B series is mounted. Failure to observe these precautions can result in severe damage to the B series!

## **CONNECTORS**

---

The U.FL antenna connector is not designed to be constantly plugged and unplugged. The antenna pin is static sensitive and you can destroy the radio with improper handling. A tiny dab of glue (epoxy, rubber cement, liquid tape or hot glue) on the connector can be used securely hold the plug in place.

The M.2 edge connector is static sensitive and should be handled carefully. The M.2 connector is not designed for repeated removal and insertion of the module.

# Assembly

## **CONFORMAL COATINGS**

---

B-Series SoM modules should not use a conformal coating to protect the module from water. Some components on the SoM cannot be coated and would need to be masked off during coating. This will make the coating process difficult to implement and test.

Furthermore, you cannot safely protect the the connection between the M.2 SoM and the M.2 NGFF connector by using a coating. Using an enclosure that protects both your base board and the B-Series SoM as a single waterproof assembly is recommended instead.

## Default settings

The B series comes pre-programmed with a bootloader and a user application called Tinker. This application works with an iOS and Android app also named Tinker that allows you to very easily toggle digital pins, take analog and digital readings and drive variable PWM outputs.

The bootloader allows you to easily update the user application via several different methods, USB, OTA, Serial Y-Modem, and also internally via the Factory Reset procedure. All of these methods have multiple tools associated with them as well.

# FCC warnings and end product labeling requirements

**Federal Communication Commission Interference Statement** This equipment has been tested and found to comply with the limits for a Class B digital device, pursuant to Part 15 of the FCC Rules. These limits are designed to provide reasonable protection against harmful interference in a residential installation. This equipment generates, uses and can radiate radio frequency energy and, if not installed and used in accordance with the instructions, may cause harmful interference to radio communications. However, there is no guarantee that interference will not occur in a particular installation. If this equipment does cause harmful interference to radio or television reception, which can be determined by turning the equipment off and on, the user is encouraged to try to correct the interference by one of the following measures:

- Reorient or relocate the receiving antenna.
- Increase the separation between the equipment and receiver.
- Connect the equipment into an outlet on a circuit different from that to which the receiver is connected.
- Consult the dealer or an experienced radio/TV technician for help.

**FCC Caution:** Any changes or modifications not expressly approved by the party responsible for compliance could void the user's authority to operate this equipment. This device complies with Part 15 of the FCC Rules. Operation is subject to the following two conditions:

1. This device may not cause harmful interference, and
2. This device must accept any interference received, including interference that may cause undesired operation.

**FCC Radiation Exposure Statement:** This equipment complies with FCC radiation exposure limits set forth for an uncontrolled environment. This transmitter module must not be co-located or operating in conjunction with any other antenna or transmitter. This End equipment should be installed and operated with a minimum distance of 20 centimeters between the radiator and your body.

**IMPORTANT NOTE:** In the event that these conditions can not be met (for example certain laptop configurations or co-location with another transmitter), then the FCC authorization is no longer considered valid and the FCC ID can not be used on the final product. In these circumstances, the OEM integrator will be responsible for re-evaluating the end product (including the transmitter) and obtaining a separate FCC authorization.

**End Product Labeling** The final end product must be labeled in a visible area with the following:

- Contains FCC ID: 2AEMI-B504

**Manual Information to the End User** The OEM integrator has to be aware not to provide information to the end user regarding how to install or remove this RF module in the user's manual of the end product which integrates this module.

# Country compatibility

Country	Technologies	Carriers
Canada	3G, Cat1	Bell Mobility, Rogers Wireless, Telus, Videotron
Mexico	3G, Cat1	AT&T, Telcel
Puerto Rico	3G, Cat1	Claro
United States	3G, Cat1	Alaska Wireless, AT&T, T-Mobile (USA), Union Telephone

## ADDITIONAL COUNTRIES

The following countries are not officially supported at this time, but may be compatible. Countries in this list can be used for prototyping and development work, but contact Particle prior to fleet deployment in these additional countries.

Country	Technologies	Carriers
Anguilla	3G, Cat1	Flow
Antigua and Barbuda	3G, Cat1	Flow
Argentina	3G, Cat1	Claro, Movistar, Personal
Bahamas	3G, Cat1	Aliv, BTC Bahamas
Barbados	3G, Cat1	Flow
Belize	3G, Cat1	Smart
Bolivia	3G, Cat1	NuevaTel
Cayman Islands	3G, Cat1	Flow
Chile	3G, Cat1	Claro, Entel, Movistar
Colombia	3G, Cat1	Movistar, Tigo
Costa Rica	3G, Cat1	Movistar
Dominica	3G, Cat1	Flow
Dominican Republic	3G, Cat1	Altice Dominicana, Claro, Viva
Ecuador	3G, Cat1	Claro, Movistar
El Salvador	3G, Cat1	Claro, Telefonica
Guadeloupe	3G, Cat1	Orange
Guatemala	3G, Cat1	Claro, Movistar
Haiti	3G	Digicel
Honduras	3G, Cat1	Claro, Tigo
Jamaica	3G, Cat1	Digicel, Flow
Nicaragua	3G	Movistar
Panama	3G, Cat1	Digicel, Movistar
Paraguay	3G, Cat1	Claro, Personal, Tigo, Vox
Peru	3G, Cat1	Claro, Entel, Movistar
Saint Kitts and Nevis	3G, Cat1	Flow
Saint Lucia	3G	Flow
Saint Vincent and the Grenadines	3G, Cat1	Flow
Trinidad and Tobago	3G, Cat1	Digicel, TSTT
Turks and Caicos Islands	3G, Cat1	Flow
Uruguay	3G, Cat1	Antel, Claro, Movistar
Venezuela	3G, Cat1	Movistar





## Ordering information

SKU	Description	Region	Modem	EtherSIM	Lifecycle	Replacement
B504MEA	B-Series LTE CAT-1/3G (NorAm, EtherSIM), [x1]	NORAM	EG91-NAX	✓	In development	
B504MTY	B-Series LTE CAT-1/3G (NorAm, EtherSIM), [x50]	NORAM	EG91-NAX	✓	In development	

## Revision history

<b>Revision</b>	<b>Date</b>	<b>Author</b>	<b>Comments</b>
pre	2024-02-28	RK	Preliminary version
	2024-05-31	RK	Update bands
	2024-06-06	RK	Update bands
001	2024-06-26	RK	Initial version