

Muon datasheet	4
Overview	5
M-SOM	5
MCU	6
BLOCK DIAGRAM	6
DEVICE FAMILIES	6
MIGRATION GUIDES	6
FEATURES	6
Feature (Bottom)	7
DIMENSIONS	8
EXPANSION CONNECTOR	8
POWER	9
USB-C cable warning	9
Expansion and peripheral power	9
Expansion card power	9
PoE power	10
LiPo battery connector	10
RF	11
APPROVED ANTENNAS	11
CERTIFIED CELLULAR ANTENNAS	11
CERTIFIED WI-FI/BLE ANTENNAS	12
CERTIFIED GNSS ANTENNAS	12
CERTIFIED LORA ANTENNAS	12
General Antenna Guidance	12
PERIPHERALS AND GPIO	12
JTAG AND SWD	13
Pin information	14
PINOUT DIAGRAM	14
PIN FUNCTION BY PARTICLE PIN NAME	14
PIN FUNCTION BY PIN NUMBER	15
PIN FUNCTION BY RASPBERRY PI GPIO NUMBER	15
GPIO (DIGITAL I/O)	16
ADC (ANALOG TO DIGITAL CONVERTER)	17
UART SERIAL	18
SPI	19
I2C	20
PWM	21
I2S	21
BOOT MODE PINS	22
BLE (BLUETOOTH LE)	23
SLEEP	23
Firmware settings	24
I/O expander	25
Expansion card	26
RASPBERRY PI HATS	26

Pi hat connection pins	26
CUSTOM EXPANSION CARDS	27
Muon expansion interface	28
EXPANSION CARD FULL PIN DETAILS	28
3V3	28
5V	29
A0	29
A1	29
A2	29
A5	30
A6	30
D0	30
D1	31
D2	31
D3	31
D4	31
D5	32
D6	32
D20	32
D21	33
D22	33
D24	33
D25	33
D26	34
D27	34
GND	34
IOEX_PA0	34
IOEX_PB7	34
MISO	34
MOSI	35
NC27	35
NC28	35
RX	35
SCK	35
TX	36
Mechanical specifications	37
DIMENSIONS AND WEIGHT	37
MECHANICAL DRAWING	37
Schematics	38
SCHEMATICS PAGE 2	38
SCHEMATICS PAGE 3	38
SCHEMATICS PAGE 4	38
SCHEMATICS PAGE 5	39
SCHEMATICS PAGE 6	39
Product Handling	41
ESD PRECAUTIONS	41
CONNECTORS	41

Default settings	42
FCC ISED CE Warnings and End Product Labeling Requirements	43
EUROPEAN UNION (CE)	45
UNITED KINGDOM	45
OUTDOOR USE (WORLD)	45
MUON404 - COUNTRY COMPATIBILITY	46
MUON404 - CERTIFIED BANDS	46
MUON524 - COUNTRY COMPATIBILITY	46
MUON524 - CERTIFIED BANDS	48
MUON635 - COUNTRY COMPATIBILITY	49
Ordering information	50
Revision history	51
Ordering information	52

Muon datasheet

This is a preliminary datasheet and there may be changed before general availability.

Overview

The Muon is a developer kit based on the M-SoM with additional peripherals for easy prototyping.

- LoRaWAN module (Quectel KG200Z, 862 – 928 MHz)
- Expansion connector
- Temperature sensor (TMP112A)
- Real-time clock and watchdog chip (AM1805)
- Ethernet (WIZnet W5500)
- Reset and mode buttons
- RGB status LED
- Power input options
 - USB-C
 - VIN (6-12 VDC)
 - LiPo battery with temperature sensor (3-pin JST-PH)

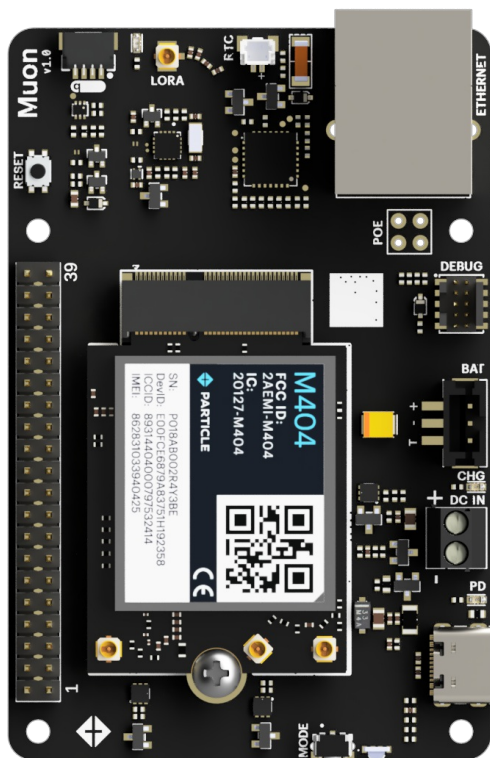

M-SOM

The Muon contains a Particle M-SoM that the following functional units:

- M.2 SoM form-factor, like the B-Series SoM
- Can use cellular or Wi-Fi (2.4 GHz or 5 GHz) for the cloud connection
- Realtek RTL8722DM MCU (BLE and Wi-Fi)
- Cellular modem
 - M404: Quectel BG95-M5 LTE Cat M1/2G (Global)
 - M524: Quectel EG91-EX LTE Cat 1 with 2G/3G fallback (EMEA)
 - M635: Quectel BG95-S5 LTE Cat M1/2G (Global with satellite)

The M404 is fully supported in the United States, Canada, and Mexico. It is in beta testing in other locations. See the [carrier list](#) for country compatibility information.

MCU

The Realtek RTL8722DM is in the same family as the P2 and Photon 2 modules (RTL8721DM), but has additional GPIO.

- 802.11a/b/g/n Wi-Fi, 2.4 GHz and 5 GHz
 - U.FL connector for external antenna
- BLE 5 using same antenna as Wi-Fi
- Realtek RTL8722DM MCU
 - ARM Cortex M33 CPU, 200 MHz
- 2048 KB (2 MB) user application maximum size
- 3072 KB (3 MB) of RAM available to user applications
- 8 MB flash file system
- FCC (United States), ISED (Canada), and CE (European Union) certified

BLOCK DIAGRAM

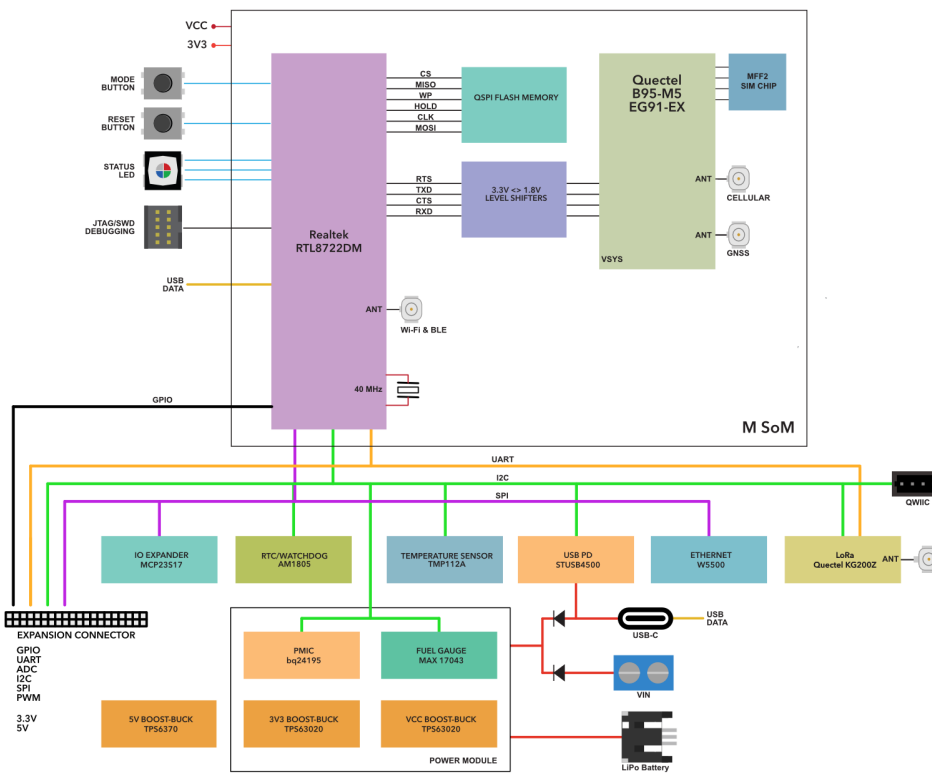

DEVICE FAMILIES

	Cellular Only	Cellular & Wi-Fi	Wi-Fi Only
Developer devices	Boron	Muon	Photon 2
Production module	B-SoM	M-SoM	P2

MIGRATION GUIDES

If you are migrating to the M-SoM from another Particle device, see also the following migration guide:

- [Muon from Argon or Boron](#)

FEATURES

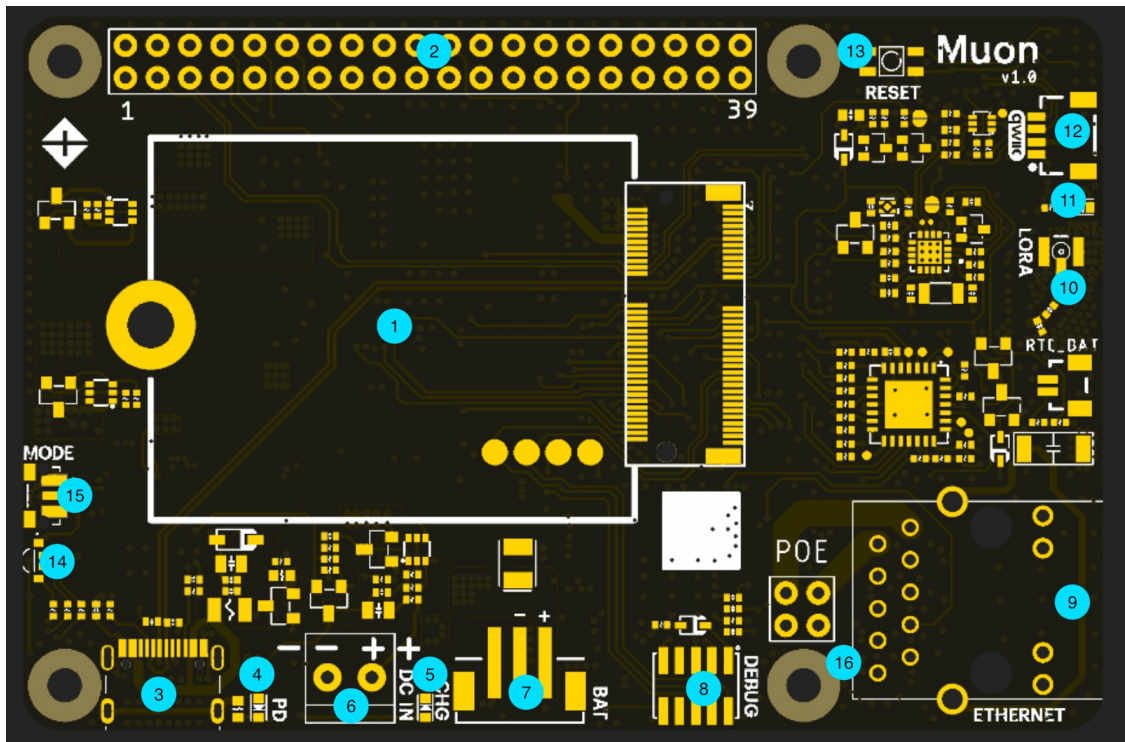

Label Feature

1	M-SoM
2	Expansion connector
3	USB-C
4	USB Power LED ("PD")
5	Charge LED ("CHG")
6	VIN (6-12 VDC)
7	LiPo battery connector (3-pin)
8	SWD/JTAG debugging connector
9	Ethernet RJ-45 connector
10	LoRaWAN antenna
11	LoRaWAN status LED
12	QWIIC (3.3V I2C) connector
13	RESET button
14	RGB status LED
15	MODE button
16	PoE HAT connector

Feature (Bottom)

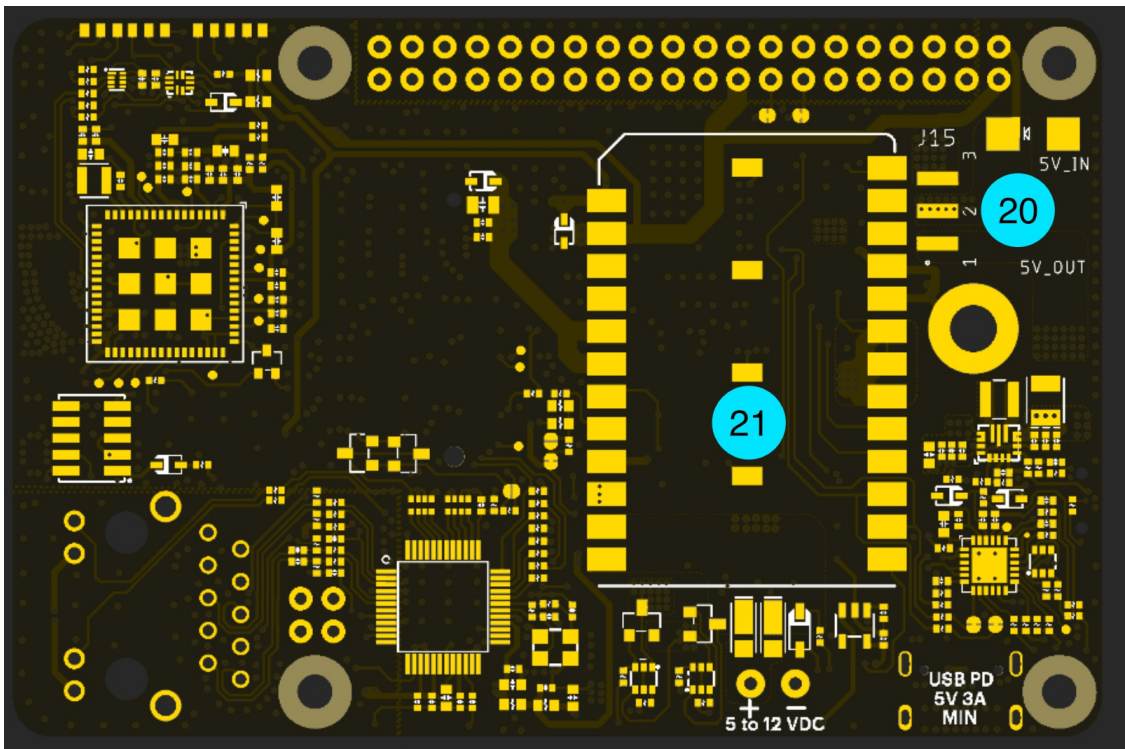

Label Feature

20	Expansion connector power jumper (J15)
21	Power module (PM-BAT)

DIMENSIONS

Overall dimensions are 56mm x 84.8mm (2.2" x 3.34").

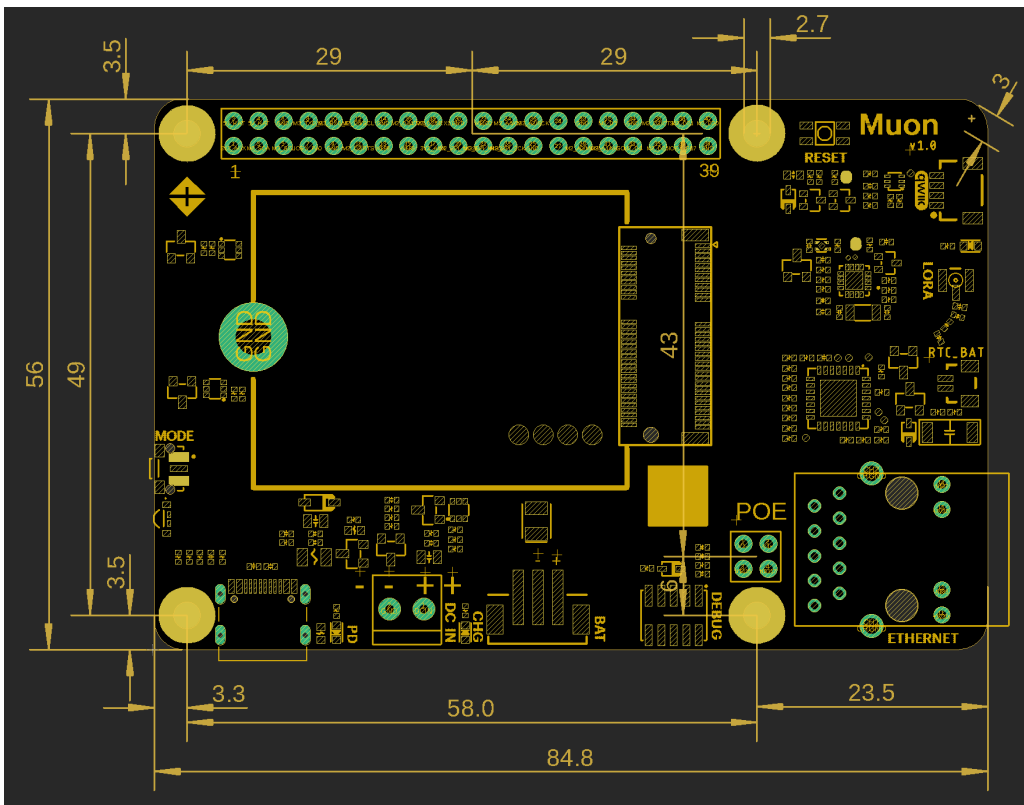

Dimensions in millimeters (mm)

EXPANSION CONNECTOR

The Muon has a 40-pin (2x20) male header pin expansion connector on the top of the board, allowing the use of many Raspberry Pi-compatible "HAT" expansion cards that sit on top of the Muon.

The expansion connector includes:

- GPIO
- I2C
- SPI
- UART serial
- PWM (pulse-width modulation)
- 3.3V power
- 5V power

All GPIO and ports are 3.3V only and are not 5V tolerant.

POWER

Power can be supplied to Muon by:

- USB-C
- VIN (6 - 12 VDC, via screw terminals)
- LiPo battery (via 3-pin JST battery connector)
- Expansion card (HAT)
- PoE (with appropriate adapter)

USB-C cable warning

You must use an actual USB-C port or USB-C power adapter to power the Muon by USB.

A USB-A to USB-C cable will not power the Muon or charge the battery

The reason is that the Muon uses USB-C PD to change the USB port voltage to 9V and request enough current to power the Muon.

When using a USB-2 or USB-3 port with USB-A to USB-C adapter cable, the USB port voltage cannot be changed and the port will not be able to power the Muon.

Also beware of some wall adapters that have a USB-C cable, but do not support USB-C PD. Some of these are advertised as Raspberry Pi power adapters, which only support 5V and cannot be used to power the Muon.

Expansion and peripheral power

The onboard peripherals including Ethernet, the LoRa radio, and the expansion card are powered by the 3V3_AUX power supply.

If you use setup.particle.io to set up your Muon, 3V3_AUX will be set up automatically.

If you want to do it manually, the see the section [Firmware settings](#), below for the sample code and the technical reasons why it is necessary.

Expansion card power

A jumper located on the bottom side of the Muon selects the direction of expansion card (HAT) 5V

power (label 20, above).

When the J15 jumper is connecting pins:

- 1 & 2: Expansion card powers the Muon (typically from PoE)
- 2 & 3: The Muon powers expansion card (from USB-C, USB, or LiPo)

PoE power

The Muon itself does not contain PoE (power over Ethernet, IEEE 802.3af/at) circuitry. It does, however, have a Raspberry Pi 5-compatible 4 pin header located next to the Ethernet jack (label 16, above).

This allows a PoE HAT to get power from the Ethernet jack, convert it to 5VDC 2A (minimum), and supply it to the Muon via the expansion connection 5V.

This is one such adapter, made by [Waveshare](#).

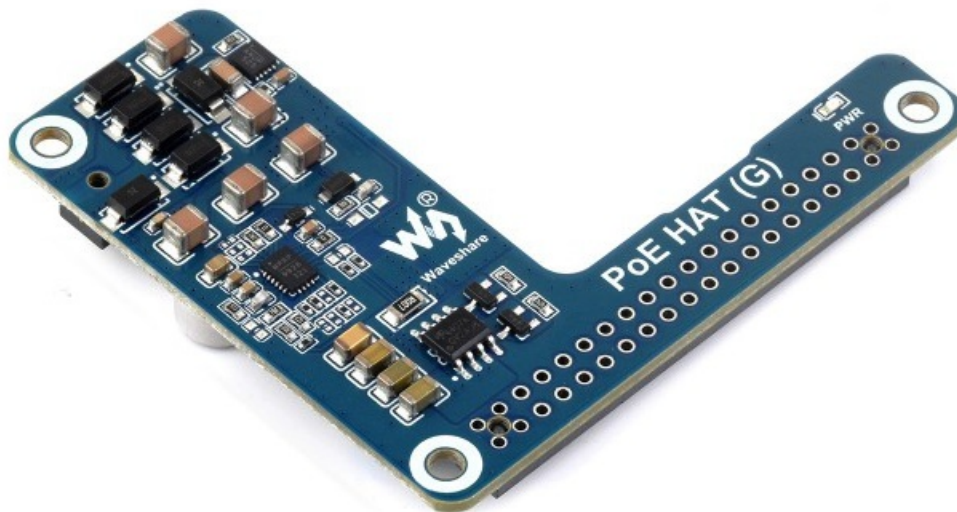

Be sure the J15 jumper is connecting pins 1 & 2 to allow the expansion connector 5V to power the Muon.

Make sure you get a PoE adapter for the Raspberry Pi 5

On all Raspberry Pi models with PoE support, there is a 4-pin plug next to the RJ45 Ethernet jack. However, on the Raspberry Pi 5 the Ethernet jack was moved to the other side of the board. This is the location where the Ethernet jack is on the Muon, as well.

If your PoE adapter has the 4-pin power jack is next to the 40-pin expansion header, you have the wrong adapter and it will not fit on the Muon.

LiPo battery connector

The Muon has a 3-pin JST-PH (2mm pitch) battery connector that is the same as the Monitor One for connection to a 3.7V LiPo battery pack with an integrated temperature sensor (10K NTC thermistor).

Some other Particle devices have a 3.7V LiPo battery without a temperature sensor using 2-pin JST-PH connector. This battery is not compatible and cannot be used with the Muon. A temperature sensor or equivalent resistance is required for proper operation; replacing the connector is not sufficient to use a battery without a temperature sensor.

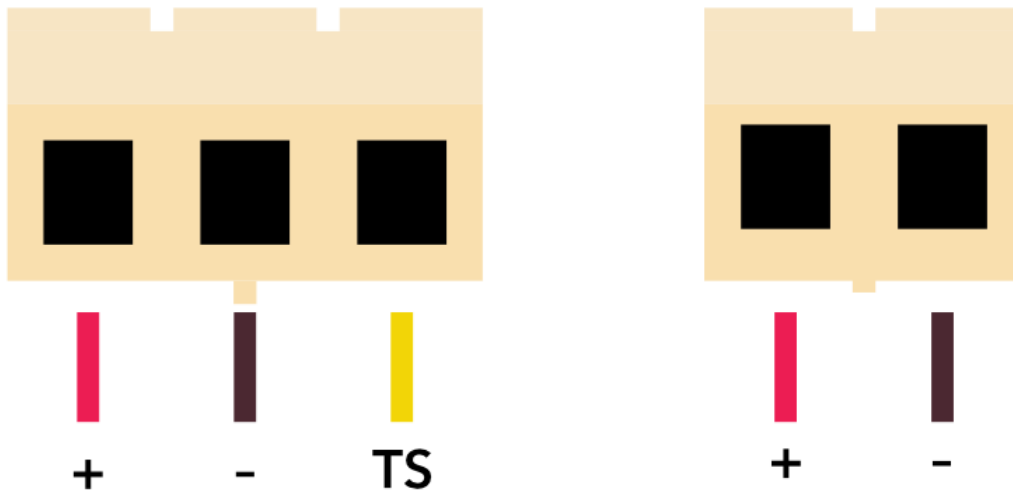

Facing the plug on the battery side

If purchasing a battery from a 3rd-party supplier, verify the polarity as the polarity is not standardized even for batteries using a JST-PH connector.

RF

- The M-SoM includes three U.FL connectors for external antennas:
 - Cellular
 - Wi-Fi (2.4 GHz and 5 GHz) and BLE
 - GNSS (GPS)
- The Muon adds an additional U.FL connector for LoRaWAN antenna.
- Wi-Fi operation in the 5150-5250 MHz band is only for indoor use to reduce the potential for harmful interference to co-channel mobile satellite systems.

APPROVED ANTENNAS

CERTIFIED CELLULAR ANTENNAS

The M-SoM is certified with the following cellular antenna:

Antenna	SKU	Details	Links
Wide band LTE cell antenna [x1]	PARANTCW1EA	M404, M524, M635	Datasheet
Wide band LTE cell antenna [x50]	PARANTCW1TY	M404, M524, M635	Datasheet

Single quantity M-SoM units and developer kits include a PARANTCW1EA antenna. Tray quantities of the M-SoM do not include antennas.

Dimension	Value	Unit
Length	116.0	mm
Width	27.0	mm
Thickness	0.2	mm
Cable Length	189.5	mm

Parameter	700/850/900	1700/1800/1900	2100	2400	2600	Unit
Peak gain						
PARANTCW1EA	2.8	5.3	5.3	5.3	5.3	dBi

CERTIFIED WI-FI/BLE ANTENNAS

The M-SoM is certified for use with the same antennas as the P2/Photon 2. The same antenna is shared for Wi-Fi and BLE. Unlike the P2/Photon 2, the external antenna is required for Wi-Fi and BLE and the M-SoM does not include a built-in trace antenna on the module.

Antenna	SKU	Links
Particle P2/Photon2 Wi-Fi Antenna 2.4/5GHz, [x1]	PARANTWM1EA	Datasheet Retail Store
Particle P2/Photon2 Wi-Fi Antenna 2.4/5GHz, [x50]	PARANTWM1TY	Datasheet

Single quantity M-SoM units and developer kits include a PARANTWM1EA antenna. Tray quantities of the M-SoM do not include antennas.

CERTIFIED GNSS ANTENNAS

SKU	Description	
PARANTGN1EA	Particle GNSS FPC Antenna, [x1]	Datasheet
PARANTGN1TY	Particle GNSS FPC Antenna, [x50]	Datasheet

Single quantity M-SoM units and developer kits include a PARANTGN1EA antenna. Tray quantities of the M-SoM do not include antennas. If not using the GNSS feature, the antenna can be omitted from your design.

- GNSS support will be added in a future version of Device OS. A [user firmware library](#) is available now for the M404.
- Feature such of high-precision, dead-reckoning, and high updates rates will require an external GNSS chip.

CERTIFIED LORA ANTENNAS

To be provided at a later date.

General Antenna Guidance

- The antenna placement needs to follow some basic rules, as any antenna is sensitive to its environment. Mount the antenna at least 10mm from metal components or surfaces, ideally 20mm for best radiation efficiency, and try to maintain a minimum of three directions free from obstructions to be able to operate effectively.
- Needs tuning with actual product enclosure and all components.

PERIPHERALS AND GPIO

Peripheral Type	Qty	Input(I) / Output(O)
Digital	20 (max)	I/O
Analog (ADC)	7 (max)	I
UART	2	I/O
SPI	2	I/O
I2C	1	I/O

USB	1	I/O
PWM	10 (max)	O

Note: All GPIOs are only rated at 3.3VDC max.

JTAG AND SWD

Muon has a Particle-standard 10-pin 2x5 SWD debugging connector. This interface can be used to debug your code or reprogram your bootloader, device OS, or the user firmware using any standard SWD tools including our Gen 3 Debugger.

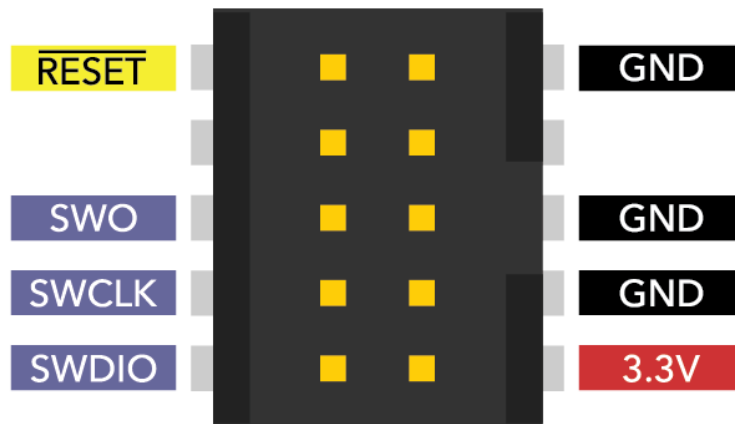

SWD is on the same pins as GPIO, so by default once user firmware boots, SWD is no longer available. This is the same as Gen 2 (STM32) but different than Gen 3 (nRF52840). Using a Debug build in Particle workbench will allow SWD to continue to run, but you will not be able to use pins A5, A6, or D27 as GPIO or ADC.

Pin	Pin Name	Description	Interface	MCU
43	A5 / D14	A5 Analog in, PWM, GPIO, shared with pin 53	SWCLK	PB[3]
53	A5 / D14	A5 Analog in, PWM, GPIO, SWCLK, shared with pin 43	SWCLK	PB[3]
55	D27	D27 GPIO, SWDIO (SWD_DATA), do not pull down at boot	SWDIO	PA[27]

- SWO (Serial Wire Output) is not supported on the RTL8722DM.
- Pins 43 and 53 are shared

I2C Address	Peripheral
0x28	STUSB4500 USB-C power controller
0x36	MAX17043 Fuel Gauge
0x48	TMP112A temperature sensor
0x61	KG200Z LoRaWAN radio
0x69	AM1805 RTC/Watchdog
0x6B	bq24195 PMIC

Pin information

PINOUT DIAGRAM

The Muon has 40-pin expansion connector mounted on the top of the board.

- 2x20 pins
- 0.1" (2.54mm) pitch in both directions
- Male header pins on top of the board
- Generally compatible with Raspberry Pi expansion connector

3V3 power	3V3_AUX	3V3	1	2	5V	5V	5V power
GPIO2 (SDA)	M2_SDA	D0	3	4	5V	5V	5V power
GPIO3 (SCL)	M2_SCL	D1	5	6	GND	GND	Ground
GPIO4 (GPKCL0)		IOEX_PA0	7	8	TX	M2_TXD_F	GPIO14 (TXD)
Ground	GND	GND	9	10	RX	M2_RXD_F	GPIO15 (RXD)
GPIO17	M2_D2/RTS	D2	11	12	D6	M2_D6/SCL	GPIO18
GPIO27	M2_A5/D14	A5	13	14	GND	GND	Ground
GPIO22	M2_SWDIO/D17	D27	15	16	D24	M2_D24/TX1	GPIO23
3V3 power	3V3_AUX	3V3	17	18	D25	M2_D25/RX1	GPIO24
GPIO10 (MOSI)	M2_SPI_MOSI	MOSI	19	20	GND	GND	Ground
GPIO9 (MISO)	M2_SPI_MISO	MISO	21	22	D22	M2_D22	GPIO25
GPIO11 (SCLK)	M2_SPI_SCK	SCK	23	24	A6	M2_A6/CS	GPIO8 (CE0)
Ground	GND	GND	25	26	A2	M2_A2/SCK	GPIO7 (CE1)
GPIO8 (ID_30)		NC27	27	28	NC28		GPIO1 (ID_30)
GPIO5	M2_A0/MOSI	A0	29	30	GND	GND	Ground
GPIO6	M2_A1/MISO	A1	31	32	D5	M2_D5	GPIO12 (PWM0)
GPIO13 (PWM1)	M2_D4	D4	33	34	GND	GND	Ground
GPIO19 (PCM_FS)	M2_D26	D26	35	36	D3	M2_D3/CTS	GPIO16
GPIO26		IOEX_PB7	37	38	D21	M2_D21	GPIO20 (PCM_DIN)
Ground	GND	GND	39	40	D20	M2_D20	GPIO21 (PCM_DOUT)

The red columns are the Raspberry Pi pin names. The gray columns are the schematic net names.

PIN FUNCTION BY PARTICLE PIN NAME

Pin Name	Module Pin			PWM	MCU	Raspberry Pi
A0 / D19	29	ADC_0		✓	PB[4]	GPIO5
A1 / D18	31	ADC_1	SPI2 (MISO)	✓	PB[5]	GPIO6
A2 / D17	26	ADC_2	SPI2 (SCK)		PB[6]	GPIO7 (CE1)
A5 / D14	13	ADC_6	SWCLK	✓	PB[3]	GPIO27
A6 / D29	24	ADC_3		✓	PB[7]	GPIO8 (CE0)
D0	3		Wire (SDA)		PB[0]	GPIO2 (SDA)
D1	5		Wire (SCL)		PA[31]	GPIO3 (SCL)
D2	11		SPI1 (SCK)	Serial1 (RTS)	PA[14]	GPIO17
D3	36		SPI1 (SS)	Serial1 (CTS)	PA[15]	GPIO16
D4	33			✓	PB[18]	GPIO13 (PWM1)
D5	32	I2S TX		✓	PB[19]	GPIO12 (PWM0)
D6	12	I2S CLK	Wire1 (SCL)	✓	PB[20]	GPIO18
D20	40	I2S TX			PA[1]	GPIO21 (PCM_DOUT)
D21	38	I2S RX			PA[0]	GPIO20 (PCM_DIN)
D22	22				PA[9]	GPIO25
D24	16				PA[7]	GPIO23
D25	18				PA[8]	GPIO24
D26	35	I2S WS			PA[4]	GPIO19 (PCM_FS)
D27	15		SWDIO		PA[27]	GPIO22

MISO / D11	21		SPI (MISO)	✓	PA[17]	GPIO9 (MISO)
MOSI / D12	19		SPI (MOSI)	✓	PA[16]	GPIO10 (MOSI)
RX / D10	10		SPI1 (MISO) Serial1 (RX)	✓	PA[13]	GPIO15 (RXD)
SCK / D13	23		SPI (SCK)		PA[18]	GPIO11 (SCLK)
TX / D9	8	I2S MCLK	SPI1 (MOSI) Serial1 (TX)	✓	PA[12]	GPIO14 (TXD)

PIN FUNCTION BY PIN NUMBER

Module Pin	Pin Name			PWM	MCU	Raspberry Pi
3	D0		Wire (SDA)		PB[0]	GPIO2 (SDA)
5	D1		Wire (SCL)		PA[31]	GPIO3 (SCL)
7	IOEX_PA0					GPIO4 (GPCKL0)
8	TX / D9	I2S MCLK	SPI1 (MOSI) Serial1 (TX)	✓	PA[12]	GPIO14 (TXD)
10	RX / D10		SPI1 (MISO) Serial1 (RX)	✓	PA[13]	GPIO15 (RXD)
11	D2		SPI1 (SCK) Serial1 (RTS)		PA[14]	GPIO17
12	D6	I2S CLK	Wire1 (SCL)	✓	PB[20]	GPIO18
13	A5 / D14	ADC_6	SWCLK	✓	PB[3]	GPIO27
15	D27		SWDIO		PA[27]	GPIO22
16	D24		Serial2 (TX)		PA[7]	GPIO23
18	D25		Serial2 (RX)		PA[8]	GPIO24
19	MOSI / D12		SPI (MOSI)	✓	PA[16]	GPIO10 (MOSI)
21	MISO / D11		SPI (MISO)	✓	PA[17]	GPIO9 (MISO)
22	D22				PA[9]	GPIO25
23	SCK / D13		SPI (SCK)		PA[18]	GPIO11 (SCLK)
24	A6 / D29	ADC_3		✓	PB[7]	GPIO8 (CE0)
26	A2 / D17	ADC_2	SPI2 (SCK)		PB[6]	GPIO7 (CE1)
27	NC27					GPIO0 (ID_SD)
28	NC28					GPIO1 (ID_SC)
29	A0 / D19	ADC_0		✓	PB[4]	GPIO5
31	A1 / D18	ADC_1	SPI2 (MISO)	✓	PB[5]	GPIO6
32	D5	I2S TX		✓	PB[19]	GPIO12 (PWM0)
33	D4			✓	PB[18]	GPIO13 (PWM1)
35	D26	I2S WS			PA[4]	GPIO19 (PCM_FS)
36	D3		SPI1 (SS) Serial1 (CTS)		PA[15]	GPIO16
37	IOEX_PB7					GPIO26
38	D21	I2S RX			PA[0]	GPIO20 (PCM_DIN)
40	D20	I2S TX			PA[1]	GPIO21 (PCM_DOUT)

PIN FUNCTION BY RASPBERRY PI GPIO NUMBER

Raspberry Pi	Pin Name	Module Pin		PWM	MCU
GPIO0 (ID_SD)	NC27	27			
GPIO1 (ID_SC)	NC28	28			
GPIO2 (SDA)	D0	3	Wire (SDA)		PB[0]
GPIO3 (SCL)	D1	5	Wire (SCL)		PA[31]
GPIO4 (GPCKL0)	IOEX_PA0	7			

GPIO5	A0 / D19	29	ADC_0			✓	PB[4]
GPIO6	A1 / D18	31	ADC_1		SPI2 (MISO)	✓	PB[5]
GPIO7 (CE1)	A2 / D17	26	ADC_2		SPI2 (SCK)		PB[6]
GPIO8 (CE0)	A6 / D29	24	ADC_3			✓	PB[7]
GPIO9 (MISO)	MISO / D11	21			SPI (MISO)	✓	PA[17]
GPIO10 (MOSI)	MOSI / D12	19			SPI (MOSI)	✓	PA[16]
GPIO11 (SCLK)	SCK / D13	23			SPI (SCK)		PA[18]
GPIO12 (PWM0)	D5	32	I2S TX			✓	PB[19]
GPIO13 (PWM1)	D4	33				✓	PB[18]
GPIO14 (TXD)	TX / D9	8	I2S MCLK		SPI1 (MOSI) Serial1 (TX)	✓	PA[12]
GPIO15 (RXD)	RX / D10	10			SPI1 (MISO) Serial1 (RX)	✓	PA[13]
GPIO16	D3	36			SPI1 (SS) Serial1 (CTS)		PA[15]
GPIO17	D2	11			SPI1 (SCK) Serial1 (RTS)		PA[14]
GPIO18	D6	12	I2S CLK	Wire1 (SCL)		✓	PB[20]
GPIO19 (PCM_FS)	D26	35	I2S WS				PA[4]
GPIO20 (PCM_DIN)	D21	38	I2S RX				PA[0]
GPIO21 (PCM_DOUT)	D20	40	I2S TX				PA[1]
GPIO22	D27	15		SWDIO			PA[27]
GPIO23	D24	16			Serial2 (TX)		PA[7]
GPIO24	D25	18			Serial2 (RX)		PA[8]
GPIO25	D22	22					PA[9]
GPIO26	IOEX_PB7	37					
GPIO27	A5 / D14	13	ADC_6	SWCLK		✓	PB[3]

GPIO (DIGITAL I/O)

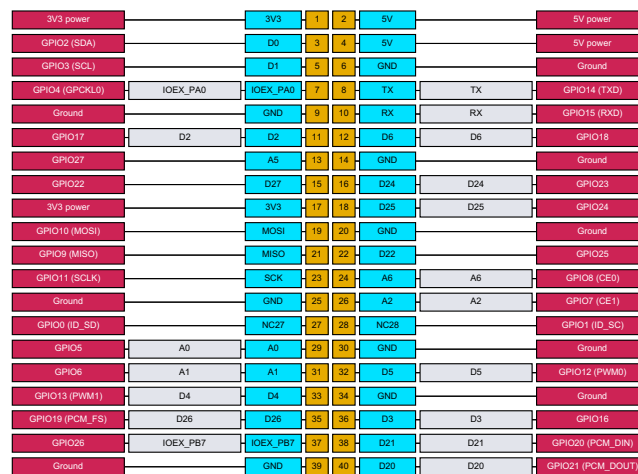

Pin	Muon Pin Name	Muon GPIO	MCU	Special boot function	Raspberry Pi
7	IOEX_PA0	✓			GPIO4 (GPCKL0)
8	TX / D9	✓	PA[12]		GPIO14 (TXD)
10	RX / D10	✓	PA[13]		GPIO15 (RXD)
11	D2	✓	PA[14]		GPIO17
12	D6	✓	PB[20]		GPIO18
16	D24	✓	PA[7]	Low at boot triggers ISP flash download	GPIO23

18	D25	✓	PA[8]	Goes high at boot	GPIO24
24	A6 / D29	✓	PB[7]		GPIO8 (CE0)
26	A2 / D17	✓	PB[6]		GPIO7 (CE1)
29	A0 / D19	✓	PB[4]		GPIO5
31	A1 / D18	✓	PB[5]		GPIO6
32	D5	✓	PB[19]		GPIO12 (PWM0)
33	D4	✓	PB[18]		GPIO13 (PWM1)
35	D26	✓	PA[4]		GPIO19 (PCM_FS)
36	D3	✓	PA[15]		GPIO16
37	IOEX_PB7	✓			GPIO26
38	D21	✓	PA[0]		GPIO20 (PCM_DIN)
40	D20	✓	PA[1]		GPIO21 (PCM_DOUT)

- All GPIO are 3.3V only and are not 5V tolerant

Certain GPIO will change state at boot, or cause the MCU to enter a special mode. See the [boot mode pins](#) section, below, for more information.

The following M.2 SoM pins are used for internal functions on the Muon and are not available on the expansion connector and cannot be used as GPIO:

Pin Name	Description	M2 Pin	Net
A3	Ethernet CS	37	ETH_CS
A4	Ethernet interrupt	39	ETH_INT
A7	PMIC interrupt	47	M2_ADC7/PMIC_INT
D8	I/O Expander INT	48	M2_D8/IOEX_INT
D22	I/O Expander Reset	62	M2_D22
D23	I/O Expander CS	64	M2_D23_IOEX_CS
D7	3V3_AUX and 5V power enable	72	D7_AUX_POWER_EN

ADC (ANALOG TO DIGITAL CONVERTER)

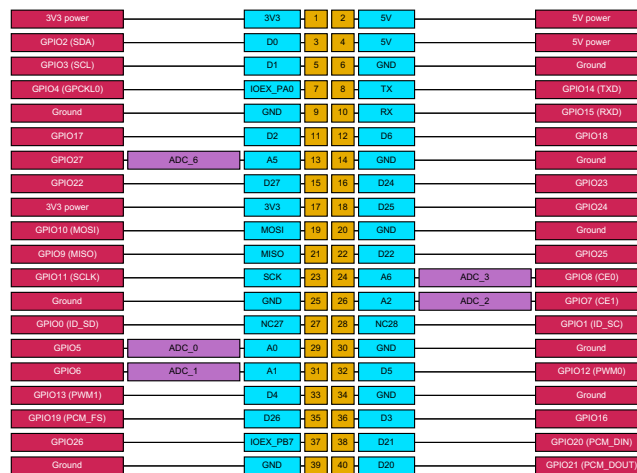

Pin	Pin Name	Description	Interface	M2 Pin	MCU	Raspberry Pi
13	A5 / D14	A5 Analog in, PWM, GPIO, shared with pin 53	ADC_6	43	PB[3]	GPIO27
24	A6 / D29	A6 Analog in, GPIO, PWM, M.2 eval PMIC INT	ADC_3	45	PB[7]	GPIO8 (CE0)

26	A2 / D17	A2 Analog in, GPIO	ADC_2	35	PB[6]	GPIO7 (CE1)
29	A0 / D19	A0 Analog in, GPIO, PWM	ADC_0	23	PB[4]	GPIO5
31	A1 / D18	A1 Analog in, GPIO, PWM	ADC_1	33	PB[5]	GPIO6

- ADC inputs are single-ended and limited to 0 to 3.3V
- Resolution is 12 bits
- SoM pin 45 (A6) on the M-SoM is shared with SoM pin 53 (SWD_CLK). You cannot use A6 and SWD at the same time. If you implement SWD on your base board, driving pin A6 will prevent SWD from functioning. The SWD_CLK will be driven at boot by the MCU.

The ADCs on the M-SoM (RTL872x) have a lower impedance than other Particle device MCUs (nRF52, STM32F2xx). They require a stronger drive and this may cause issues when used with a voltage divider. This is particularly true for A7, which has an even lower impedance than other ADC inputs.

For signals that change slowly, such as NTC thermocouple resistance, you can add a 2.2 uF capacitor to the signal. For rapidly changing signals, a voltage follower IC can be used.

UART SERIAL

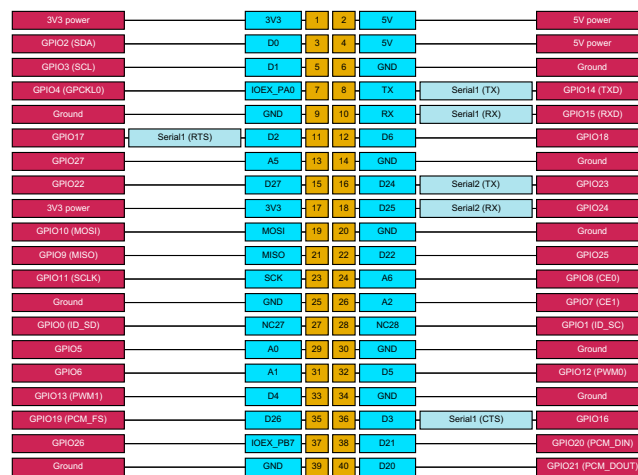

Pin	Pin Name	Description	Interface	M2 Pin	MCU	Raspberry Pi
8	TX / D9	Serial TX, PWM, GPIO, SPI1 MOSI, I2S MCLK	Serial1 (TX)	36	PA[12]	GPIO14 (TXD)
10	RX / D10	Serial RX, PWM, GPIO, SPI1 MISO	Serial1 (RX)	38	PA[13]	GPIO15 (RXD)
11	D2	D2 GPIO, Serial RTS flow control (optional), SPI1 SCK	Serial1 (RTS)	42	PA[14]	GPIO17
16	D24	D24 GPIO, Serial2 TX, do not pull down at boot	Serial2 (TX)	58	PA[7]	GPIO23
18	D25	GPIO25, Serial2 RX	Serial2 (RX)	60	PA[8]	GPIO24
36	D3	D3 GPIO, Serial1 CTS flow control (optional), SPI1 SS	Serial1 (CTS)	40	PA[15]	GPIO16

- The UART pins are 3.3V and must not be connected directly to a RS-232C port or to a 5V TTL serial port
- Hardware flow control is optional; if not used then the RTS and CTS pins can be used as regular GPIO
- Supported baud rates: 110, 300, 600, 1200, 9600, 14400, 19200, 28800, 38400, 57600, 76800, 115200, 128000, 153600, 230400, 500000, 921600, 1000000, 1382400, 1444400, 1500000, 1843200, 2000000, 2100000, 2764800, 3000000, 3250000, 3692300, 3750000, 4000000, 6000000

On the Muon, Serial1 is available on the expansion connector. If Serial1 is not needed on these

pins, they can be used as GPIO.

If using an expansion card that requires UART serial, generally the following pins are used on standard Raspberry Pi expansion cards. These cards generally do not support hardware flow control.

Pin	Pin Name	Description	Interface	M2 Pin	MCU	Raspberry Pi
8	TX / D9	Serial TX, PWM, GPIO, SPI1 MOSI, I2S MCLK	TXD	36	PA[12]	GPIO14 (TXD)
10	RX / D10	Serial RX, PWM, GPIO, SPI1 MISO	RXD	38	PA[13]	GPIO15 (RXD)

The LoRaWAN radio is normally communicated to via I2C. There is a GPIO controlled switch that connects the MCU SerialI port to either the expansion connector (the default state), or to the LoRaWAN radio. The latter is only used for reprogramming the radio software from the main MCU.

SPI

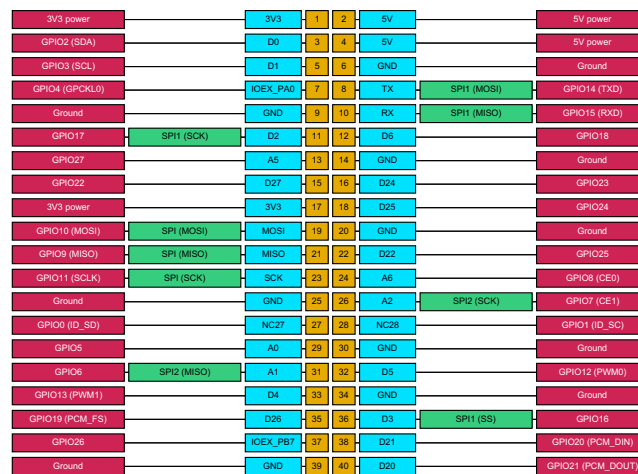

Pin	Pin Name	Description	Interface	M2 Pin	MCU	Raspberry Pi
8	TX / D9	Serial TX, PWM, GPIO, SPI1 MOSI, I2S MCLK	SPI1 (MOSI)	36	PA[12]	GPIO14 (TXD)
10	RX / D10	Serial RX, PWM, GPIO, SPI1 MISO	SPI1 (MISO)	38	PA[13]	GPIO15 (RXD)
11	D2	D2 GPIO, Serial RTS flow control (optional), SPI1 SCK	SPI1 (SCK)	42	PA[14]	GPIO17
19	MOSI / D12	D12 GPIO, PWM, SPI MOSI	SPI (MOSI)	52	PA[16]	GPIO10 (MOSI)
21	MISO / D11	D11 GPIO, PWM, SPI MISO	SPI (MISO)	50	PA[17]	GPIO9 (MISO)
23	SCK / D13	D13 GPIO, SPI SCK	SPI (SCK)	54	PA[18]	GPIO11 (SCLK)
26	A2 / D17	A2 Analog in, GPIO	SPI2 (SCK)	35	PB[6]	GPIO7 (CE1)
31	A1 / D18	A1 Analog in, GPIO, PWM	SPI2 (MISO)	33	PB[5]	GPIO6
36	D3	D3 GPIO, SerialI CTS flow control (optional), SPI1 SS	SPI1 (SS)	40	PA[15]	GPIO16

- The SPI port is 3.3V and must not be connected directly to devices that drive MISO at 5V
- Any pins can be used as the SPI chip select, however certain pins are generally used for Raspberry Pi expansion cards.
- Multiple devices can generally share a single SPI port
- The expansion connector SPI pins are connected to SPI.

If using an expansion card that requires SPI, generally the following pins are used. The pins **CE0**

and CE1 are generally used for SPI chip select on standard Raspberry Pi expansion cards.

Pin	Pin Name	Description	Interface	M2 Pin	MCU	Raspberry Pi
19	MOSI / D12	D12 GPIO, PWM, SPI MOSI	MOSI	52	PA[16]	GPIO10 (MOSI)
21	MISO / D11	D11 GPIO, PWM, SPI MISO	MISO	50	PA[17]	GPIO9 (MISO)
23	SCK / D13	D13 GPIO, SPI SCK	SCLK	54	PA[18]	GPIO11 (SCLK)
24	A6 / D29	A6 Analog in, GPIO, PWM, M.2 eval PMIC INT	CE0	45	PB[7]	GPIO8 (CE0)
26	A2 / D17	A2 Analog in, GPIO	CE1	35	PB[6]	GPIO7 (CE1)

Expansion cards GPIO10 (MOSI), GPIO9 (MISO), and GPIO11(SCLK) can only be used for SPI. They cannot be used as GPIO because the SPI bus is used for internal peripherals on the Muon. You can, however, use GPIO8 (CE0) and GPIO7 (CE1) as GPIO if not using them for SPI.

I2C

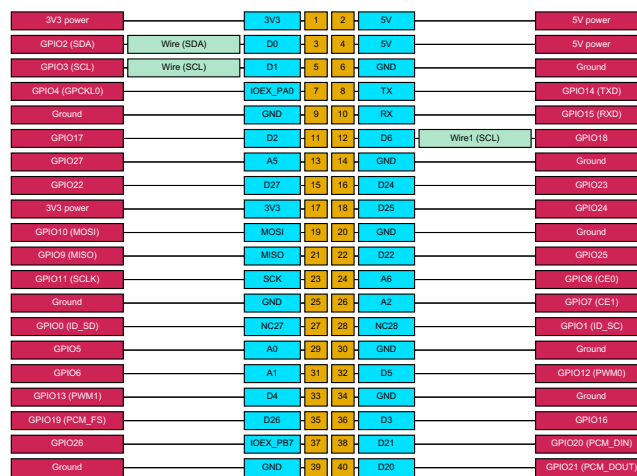

Pin	Pin Name	Description	Interface	M2 Pin	MCU	Raspberry Pi
3	D0	D0 GPIO, I2C SDA	Wire (SDA)	22	PB[0]	GPIO2 (SDA)
5	D1	D1 GPIO, I2C SCL	Wire (SCL)	20	PA[31]	GPIO3 (SCL)
12	D6	D6 GPIO, PWM, I2S CLK	Wire1 (SCL)	70	PB[20]	GPIO18

- The I2C port is 3.3V and must not be connected directly a 5V I2C bus
- Maximum bus speed is 400 kHz

On the Muon, Wire is available on the expansion connector on the following pins:

Pin	Pin Name	Description	Interface	M2 Pin	MCU	Raspberry Pi
3	D0	D0 GPIO, I2C SDA	SDA	22	PB[0]	GPIO2 (SDA)
5	D1	D1 GPIO, I2C SCL	SCL	20	PA[31]	GPIO3 (SCL)

Raspberry Pi GPIO2 and GPIO3 can only be used as I2C, not as GPIO, This is because the I2C is also used for peripherals on the Muon. You cannot use these I2C addresses on expansion cards as they will conflict with built-in peripherals.

I2C Address Peripheral

0x28	STUSB4500 USB-C power controller
0x36	MAX17043 Fuel Gauge
0x48	TMP112A temperature sensor

0x61	KG200Z LoRaWAN radio
0x69	AM1805 RTC/Watchdog
0x6B	bq24195 PMIC

PWM

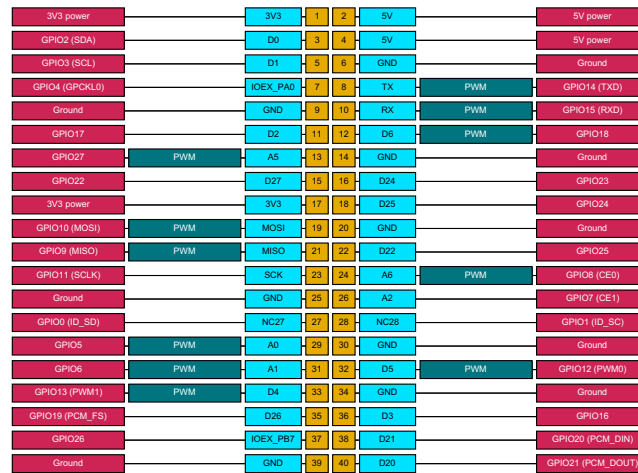

Pin	Pin Name	Description	M2 Pin	MCU	Raspberry Pi
8	TX / D9	Serial TX, PWM, GPIO, SPI1 MOSI, I2S MCLK	36	PA[12]	GPIO14 (TXD)
10	RX / D10	Serial RX, PWM, GPIO, SPI1 MISO	38	PA[13]	GPIO15 (RXD)
12	D6	D6 GPIO, PWM, I2S CLK	70	PB[20]	GPIO18
13	A5 / D14	A5 Analog in, PWM, GPIO, shared with pin 53	43	PB[3]	GPIO27
19	MOSI / D12	D12 GPIO, PWM, SPI MOSI	52	PA[16]	GPIO10 (MOSI)
21	MISO / D11	D11 GPIO, PWM, SPI MISO	50	PA[17]	GPIO9 (MISO)
24	A6 / D29	A6 Analog in, GPIO, PWM, M.2 eval PMIC INT	45	PB[7]	GPIO8 (CE0)
29	A0 / D19	A0 Analog in, GPIO, PWM	23	PB[4]	GPIO5
31	A1 / D18	A1 Analog in, GPIO, PWM	33	PB[5]	GPIO6
32	D5	D5 GPIO, PWM, I2S TX	68	PB[19]	GPIO12 (PWM0)
33	D4	D4 GPIO, PWM	66	PB[18]	GPIO13 (PWM1)

- All available PWM pins on the M-SoM share a single timer. This means that they must all share a single frequency, but can have different duty cycles.

If using an expansion card that requires PWM, generally the following pins are used on standard Raspberry Pi expansion cards.

Pin	Pin Name	Description	Interface	M2 Pin	MCU	Raspberry Pi
13	A5 / D14	A5 Analog in, PWM, GPIO, shared with pin 53	PWM1	43	PB[3]	GPIO27
32	D5	D5 GPIO, PWM, I2S TX	PWM0	68	PB[19]	GPIO12 (PWM0)
33	D4	D4 GPIO, PWM	PWM1	66	PB[18]	GPIO13 (PWM1)
35	D26	D26 GPIO, I2S WS	GPIO19	59	PA[4]	GPIO19 (PCM_FS)

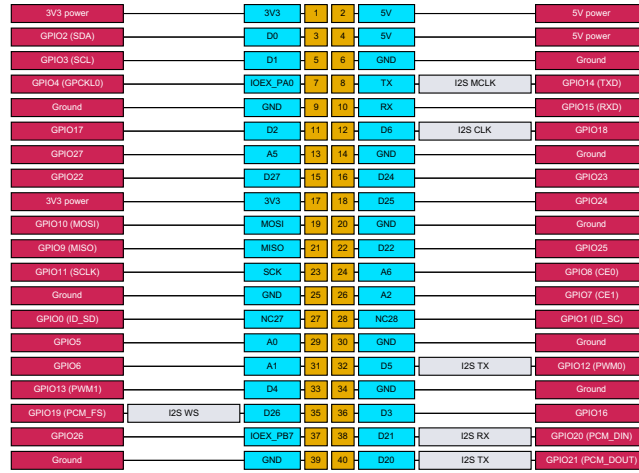

Pin	Pin Name	Description	M2 Pin	MCU	Raspberry Pi
8	TX / D9	Serial TX, PWM, GPIO, SPI1 MOSI, I2S MCLK	36	PA[12]	GPIO14 (TXD)
12	D6	D6 GPIO, PWM, I2S CLK	70	PB[20]	GPIO18
32	D5	D5 GPIO, PWM, I2S TX	68	PB[19]	GPIO12 (PWM0)
35	D26	D26 GPIO, I2S WS	59	PA[4]	GPIO19 (PCM_FS)
38	D21	D21 GPIO, I2S RX	17	PA[0]	GPIO20 (PCM_DIN)
40	D20	D20 GPIO, I2S TX	19	PA[1]	GPIO21 (PCM_DOUT)

- Note that this is I2S ("sound") not I2C.
- Only I2S, not raw PCM frames, are supported.
- A third party library is required for I2S; it is not built into Device OS.
- PDM is not available on the Muon, but an I2S microphone can be used instead of a PDM microphone.

The Muon is only compatible with Raspberry Pi expansion cards that support I2S on the PCM pins, not cards that use raw PCM frames. Generally the following pins are used on standard Raspberry Pi expansion cards that use I2S:

Pin	Pin Name	Description	Interface	M2 Pin	MCU	Raspberry Pi
35	D26	D26 GPIO, I2S WS	PCM_FS	59	PA[4]	GPIO19 (PCM_FS)
38	D21	D21 GPIO, I2S RX	PCM_DIN	17	PA[0]	GPIO20 (PCM_DIN)
40	D20	D20 GPIO, I2S TX	PCM_DOUT	19	PA[1]	GPIO21 (PCM_DOUT)

PDM cannot be used on Muon expansion cards as the M-SoM PDM pins (A2, A3) are used for internal peripherals and are not available on the expansion connector.

BOOT MODE PINS

These pins have a special function at boot. Beware when using these pins as input as they can trigger special modes in the MCU.

Pin	Pin Name	Description	M2 Pin	MCU	Raspberry Pi
13	A5 / D14	SWCLK. 40K pull-down at boot.	43	PB[3]	GPIO27
15	D27	SWDIO. 40K pull-up at boot. Low at boot triggers MCU test mode.	55	PA[27]	GPIO22
16	D24	Low at boot triggers ISP flash download	58	PA[7]	GPIO23

BLE (BLUETOOTH LE)

If you wish to use Wi-Fi on the M-SoM you will need to provide a way to configure it. Wi-Fi setup works the same as the P2, Photon 2, and Argon, and uses BLE. See [Wi-Fi setup options](#) for more information.

BLE 5.3 BLE Central Mode and BLE Peripheral Mode are supported.

Full-speed BLE modes such as A2DP used for BLE audio are not supported.

Wi-Fi and BLE share the same antenna so you do not need to include a separate antenna to use both.

SLEEP

The Muon/M-SoM can wake from `STOP` or `ULTRA_LOW_POWER` sleep mode on any GPIO, `RISING`, `FALLING`, or `CHANGE`.

The Muon/M-SoM can only wake from `HIBERNATE` sleep mode on on certain pins, `RISING`, `FALLING`, or `CHANGE`.

The Muon/M-SoM preserves the state of outputs during `STOP` or `ULTRA_LOW_POWER` sleep mode. In `HIBERNATE`, outputs are high-impedance.

Most pins can use `INPUT_PULLUP` or `INPUT_PULLDOWN` in sleep modes. The exception is `HIBERNATE` sleep mode where pin D21 can only use an external hardware pull-up or pull down.

Pin	Pin Name	Description	Interface	M2 Pin	MCU
8	TX / D9	Serial TX, PWM, GPIO, SPI1 MOSI, I2S MCLK	Pin can wake from HIBERNATE sleep	36	PA[12]
10	RX / D10	Serial RX, PWM, GPIO, SPI1 MISO	Pin can wake from HIBERNATE sleep	38	PA[13]
11	D2	D2 GPIO, Serial RTS flow control (optional), SPI1 SCK	Pin can wake from HIBERNATE sleep	42	PA[14]
36	D3	D3 GPIO, Serial CTS flow control (optional), SPI1 SS	Pin can wake from HIBERNATE sleep	40	PA[15]
38	D21	D21 GPIO, I2S RX	No internal pull up or pull down in HIBERNATE sleep mode.	17	PA[0]

Firmware settings

Devices using the [Particle Power Module](#) include a 3V3_AUX power output that can be controlled by a GPIO. On the M.2 SoM breakout board, this powers the Feather connector. On the Muon, it powers the Ethernet port, LoRaWAN module, 40-pin expansion HAT connector, and QWIIC connector.

The main reason for this is that until the PMIC is configured, the input current with no battery connected is limited to 100 mA. This is insufficient for the M-SoM to boot when using a peripheral that requires a lot of current, like the WIZnet W5500 Ethernet module. The system power manager prevents turning on 3V3_AUX until after the PMIC is configured and the PMIC has negotiated a higher current from the USB host (if powered by USB).

This setting is persistent and only needs to be set once. In fact, the PMIC initialization normally occurs before user firmware is run. This is also necessary because if you are using Ethernet and enter safe mode (breathing magenta), it's necessary to enable 3V3_AUX so if you are using Ethernet, you can still get OTA updates while in safe mode.

After changing the auxiliary power configuration you must reset the device.

The following code can be used to enable Ethernet on the M.2 SoM breakout board. This only needs to be done once and the device must be reset after configuration for the changes to take effect. It requires Device OS 5.9.0 or later.

```
// Enable 3V3_AUX
SystemPowerConfiguration powerConfig = System.getPowerConfiguration();
powerConfig.auxiliaryPowerControlPin(D7).interruptPin(A6);
System.setPowerConfiguration(powerConfig);

// Enable Ethernet
if_wiznet_pin_remap remap = {};
remap.base.type = IF_WIZNET_DRIVER_SPECIFIC_PIN_REMAP;

System.enableFeature(FEATURE_ETHERNET_DETECTION);
remap.cs_pin = D5;
remap.reset_pin = PIN_INVALID;
remap.int_pin = PIN_INVALID;
auto ret = if_request(nullptr, IF_REQ_DRIVER_SPECIFIC, &remap, sizeof(remap),
nullptr);
```

If you are not using Ethernet and wish to manage the 3V3_AUX power manually from your firmware, you can set the `auxiliaryPowerControlPin` to `PIN_INVALID` and reset the device. It will then no longer turn on at boot.

```
// Manual management of 3V3_AUX
SystemPowerConfiguration powerConfig =
System.getPowerConfiguration();
powerConfig.auxiliaryPowerControlPin(PIN_INVALID).interruptPin(A6);
System.setPowerConfiguration(powerConfig);
```

To control 3V3_AUX manually from your firmware, use `pinMode(D7, OUTPUT)` in `setup()`. Use `digitalWrite(D7, 1)` to turn 3V3_AUX on and `digitalWrite(D7, 0)` to turn it off.

I/O expander

A MCP23S17 GPIO expander is present on the Muon board for internal use. It is connected to primary SPI along with Ethernet (W5500).

- IOEX CS: D8
- IOEX RESET: D22

The following are connected to the I/O Expander:

Port	Net	Description
INTA	D2_D8/IOEX_INT	Interrupt output to MCU
CS	M2_D23/IOEX_CS	SPI chip select from MCU
GPA0	IOEX_PA0	Expansion connector GPIO
GPA1	RTC_INT	FOUT/IRQ from AB1805
GPA2	TEMP_ALERT	TMP112 temperature sensor alert
GPA3	PD_ALERT	STUSB4500 USB-C PD alert interrupt
GPA4	PD_ATTACH	STUSB4500 USB-C PD attach interrupt
GPA5	IOEX_PA5	
GPA6	IOEX_PA6	
GPA7	LORA_ALERT	KG200Z LoRa alert interrupt
GPB0	LORA_BOOT	KG200Z LoRa boot mode select
GPB1	LORA_BUS_SEL	KG200Z LoRa I2C/UART interface select
GPB2	LORA_RST	KG200Z LoRa reset
GPB3	IOEX_PB3	
GPB4	PD_RST	STUSB4500 USB-C PD reset
GPB5	ETHERNET_RESET	W5500 Ethernet reset
GPB6	IOEX_PB6	
GPB7	IOEX_PB7	Expansion connector GPIO

Expansion card

The Muon can be expanded in several ways:

- Qwiic or Stemma-QT I2C peripherals
- Raspberry Pi HATs
- Dupont wires or ribbon cables to a solderless breadboard
- A custom expansion card that sits on top of the Muon

RASPBERRY PI HATS

The Muon can be used with some Raspberry Pi expansion cards ("HATs") that sit on top of a Raspberry Pi. Note, however, that are limitations:

- Since the Muon is not a Raspberry Pi, even though the hardware fits, there may not be suitable software to use it.
- The Pi HAT cannot be used to power the Muon.
- Some pins have limitations.

See [Muon HATs](#) for more information.

Pi hat connection pins

Pin	Pi Pin Name	Pin Name	Description	Serial	SPI	I2C	I2S
1	3V3 power	3V3	3.3V power to expansion card				
2	5V power	5V	5V power to expansion card				
3	GPIO2 (SDA)	D0	D0 GPIO, I2C SDA			Wire (SDA)	
4	5V power	5V	5V power to expansion card				
5	GPIO3 (SCL)	D1	D1 GPIO, I2C SCL			Wire (SCL)	
6	Ground	GND	Ground				
7	GPIO4 (GPCKL0)	IOEX_PA0					
8	GPIO14 (TXD)	TX / D9	Serial TX, PWM, GPIO, SPI1 MOSI, I2S MCLK	Serial1 (TX)	SPI1 (MOSI)		I2S MCLK
9	Ground	GND	Ground				
10	GPIO15 (RXD)	RX / D10	Serial RX, PWM, GPIO, SPI1 MISO	Serial1 (RX)	SPI1 (MISO)		
11	GPIO17	D2	D2 GPIO, Serial RTS flow control (optional), SPI1 SCK	Serial1 (RTS)	SPI1 (SCK)		
12	GPIO18	D6	D6 GPIO, PWM, I2S CLK			Wire1 (SCL)	I2S CLK
13	GPIO27	A5 / D14	A5 Analog in, PWM, GPIO, shared with pin 53				
14	Ground	GND	Ground				
15	GPIO22	D27	D27 GPIO, SWDIO (SWD_DATA), do not pull down at boot				
16	GPIO23	D24	D24 GPIO, Serial2 TX, do not pull down at boot	Serial2 (TX)			
17	3V3 power	3V3	3.3V power to expansion card				

18	GPIO24	D25	GPIO25, Serial2 RX	Serial2 (RX)	
19	GPIO10 (MOSI)	MOSI / D12	D12 GPIO, PWM, SPI MOSI		SPI (MOSI)
20	Ground	GND	Ground		
21	GPIO9 (MISO)	MISO / D11	D11 GPIO, PWM, SPI MISO		SPI (MISO)
22	GPIO25	D22	D22 GPIO		
23	GPIO11 (SCLK)	SCK / D13	D13 GPIO, SPI SCK		SPI (SCK)
24	GPIO8 (CE0)	A6 / D29	A6 Analog in, GPIO, PWM, M.2 eval PMIC INT		
25	Ground	GND	Ground		
26	GPIO7 (CE1)	A2 / D17	A2 Analog in, GPIO		SPI2 (SCK)
27	GPIO0 (ID_SD)	NC27			
28	GPIO1 (ID_SC)	NC28			
29	GPIO5	A0 / D19	A0 Analog in, GPIO, PWM		
30	Ground	GND	Ground		
31	GPIO6	A1 / D18	A1 Analog in, GPIO, PWM		SPI2 (MISO)
32	GPIO12 (PWM0)	D5	D5 GPIO, PWM, I2S TX		I2S TX
33	GPIO13 (PWM1)	D4	D4 GPIO, PWM		
34	Ground	GND	Ground		
35	GPIO19 (PCM_FS)	D26	D26 GPIO, I2S WS		I2S WS
36	GPIO16	D3	D3 GPIO, Serial1 CTS flow control (optional), SPI1 SS	Serial1 (CTS)	SPI1 (SS)
37	GPIO26	IOEX_PB7			
38	GPIO20 (PCM_DIN)	D21	D21 GPIO, I2S RX		I2S RX
39	Ground	GND	Ground		
40	GPIO21 (PCM_DOUT)	D20	D20 GPIO, I2S TX		I2S TX

Of note:

- Pi pin 27 (GPIO0, ID_SD) and pin 28 (GPIO1, ID_SC) are NC and cannot be used. They are normally used for a Pi boot ROM, which isn't applicable to the Muon.
- Pi pin 3 (GPIO2, SDA) and pin 5 (GPIO3, SCL) can only be used for I2C and not GPIO, as the I2C port is shared with the Muon.
- Pi pin 19 (GPIO10, MOSI), pin 21 (GPIO9, MISO), and pin 23 (GPIO11, SCLK) can only be used for SPI and not GPIO, as the SPI port is shared with the Muon
- Pi pin 7 (GPIO4) and pin 37 (GPIO26) are connected to the I/O expander, not directly to the MCU, so there may be limitations.
- See also [boot mode pins](#), above, for other pins with special functions to be aware of.

CUSTOM EXPANSION CARDS

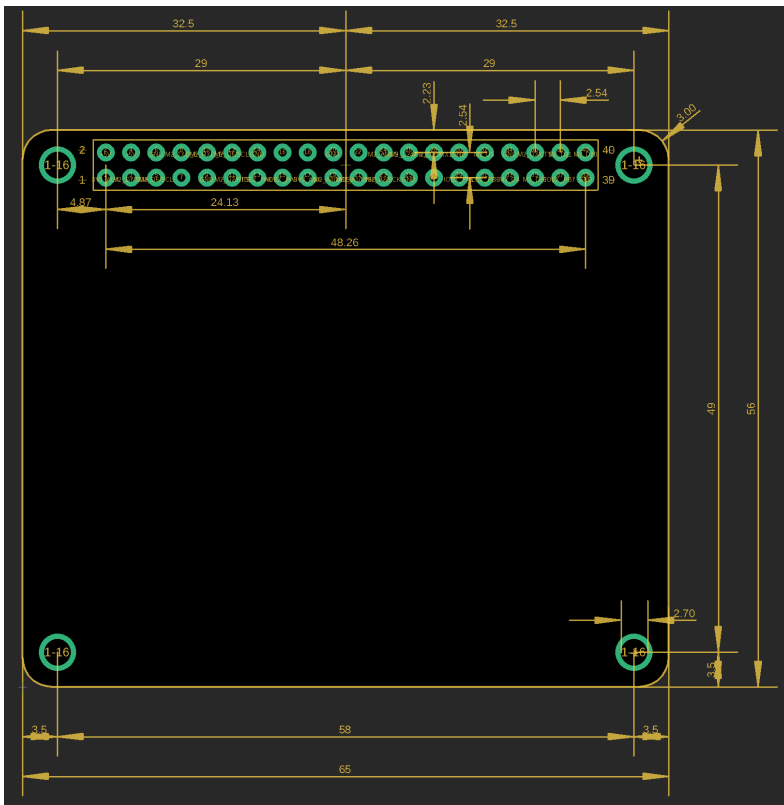

Dimensions in millimeters (mm)

The expansion card is intended to be 65mm x 56mm and connects to the Muon using a 40-pin female socket (0.1" pitch, 2x20). The expansion card has a female socket on the bottom that mates with the male header pins on the top of the Muon. It's a "HAT" configuration.

The sample design uses a PTH (through-hole) female socket for strength and to make it easier to assemble with SMD components on the top of the expansion card, but you can use a SMD header reflowed to bottom instead if you prefer.

Muon expansion interface

3V3 power	3V3_AUX	3V3	1	2	5V	5V	5V power
GPIO2 (SDA)	M2_SDA	D0	3	4	5V	5V	5V power
GPIO3 (SCL)	M2_SCL	D1	5	6	GND	GND	Ground
GPIO4 (GPOK0)		IOEX_PAD	7	8	TX	M2_TXD_F	GPIO14 (TXD)
Ground	GND	GND	9	10	RX	M2_RXD_F	GPIO15 (RXD)
GPIO17	M2_D2RTS	D2	11	12	D5	M2_D6/SCL	GPIO18
GPIO27	M2_A5/D14	A5	13	14	GND	GND	Ground
GPIO22	M2_SWDI/D17	D27	15	16	D24	M2_D24/TX1	GPIO23
3V3 power	3V3_AUX	3V3	17	18	D25	M2_D25/RX1	GPIO24
GPIO10 (MOSI)	M2_SPI_MOSI	MOSI	19	20	GND	GND	Ground
GPIO9 (MISO)	M2_SPI_MISO	MISO	21	22	D22	M2_D22	GPIO25
GPIO11 (SCLK)	M2_SPI_SCK	SCK	23	24	A6	M2_A6/CS	GPIO8 (CE0)
Ground	GND	GND	25	26	A2	M2_A2/SCK	GPIO7 (CE1)
GPIO0 (ID_SD)		NC27	27	28	NC28		GPIO1 (ID_SC)
GPIO5	M2_A0/MOSI	A0	29	30	GND	GND	Ground
GPIO6	M2_A1/MISO	A1	31	32	D5	M2_D5	GPIO12 (PWM0)
GPIO13 (PWM1)	M2_D4	D4	33	34	GND	GND	Ground
GPIO19 (PCM_FS)	M2_D26	D26	35	36	D3	M2_D5/CTS	GPIO16
GPIO26		IOEX_PB7	37	38	D21	M2_D21	GPIO20 (PCM_DIN)
Ground	GND	GND	39	40	D20	M2_D20	GPIO21 (PCM_DOUT)

EXPANSION CARD FULL PIN DETAILS

This section is very long; you can [skip over it](#) if desired.

3V3

Details

Pin Name	3V3
Description	3.3V power to expansion card

5V**Details**

Pin Name	5V
Description	5V power to expansion card

A0**Details**

Pin Name	A0
Pin Alternate Name	D19
Description	A0 Analog in, GPIO, PWM
Supports digitalRead	Yes
Supports digitalWrite	Yes
Supports analogRead	Yes
Supports analogWrite (PWM)	Yes
Supports tone	Yes
Supports attachInterrupt	Yes
Internal pull resistance	42K
MCU Pin	PB[4]
M.2 connector pin number	23

A1**Details**

Pin Name	A1
Pin Alternate Name	D18
Description	A1 Analog in, GPIO, PWM
Supports digitalRead	Yes
Supports digitalWrite	Yes
Supports analogRead	Yes
Supports analogWrite (PWM)	Yes
Supports tone	Yes
SPI interface	MISO. Use SPI2 object.
Supports attachInterrupt	Yes
Internal pull resistance	???
MCU Pin	PB[5]
M.2 connector pin number	33

A2**Details**

Pin Name	A2
Pin Alternate Name	D17
Description	A2 Analog in, GPIO

Supports digitalRead	Yes
Supports digitalWrite	Yes
Supports analogRead	Yes
SPI interface	SCK. Use SPI2 object.
Supports attachInterrupt	Yes
Internal pull resistance	22K
MCU Pin	PB[6]
M.2 connector pin number	35

A5

Details

Pin Name	A5
Pin Alternate Name	D14
Description	A5 Analog in, PWM, GPIO, shared with pin 53
Supports analogRead	Yes
Supports analogWrite (PWM)	Yes
Supports tone	Yes
Internal pull resistance	???
SWD interface	SWCLK. 40K pull-down at boot.
Signal used at boot	SWCLK. 40K pull-down at boot.
MCU Pin	PB[3]
M.2 connector pin number	43

A6

Details

Pin Name	A6
Pin Alternate Name	D29
Description	A6 Analog in, GPIO, PWM, M.2 eval PMIC INT
Supports digitalRead	Yes
Supports digitalWrite	Yes
Supports analogRead	Yes
Supports analogWrite (PWM)	Yes
Supports tone	Yes
Supports attachInterrupt	Yes
Internal pull resistance	???
MCU Pin	PB[7]
M.2 connector pin number	45

D0

Details

Pin Name	D0
Description	D0 GPIO, I2C SDA
I2C interface	SDA. Use Wire object. Use 1.5K to 10K external pull-up resistor.
Internal pull resistance	???
MCU Pin	PB[0]

M.2 connector pin number 22

D1

Details

Pin Name	D1
Description	D1 GPIO, I2C SCL
I2C interface	SCL. Use Wire object. Use 1.5K to 10K external pull-up resistor.
Internal pull resistance	???
MCU Pin	PA[31]
M.2 connector pin number	20

D2

Details

Pin Name	D2
Description	D2 GPIO, Serial RTS flow control (optional), SPI SCK
Supports digitalRead	Yes
Supports digitalWrite	Yes
UART serial	RTS. Use Serial1 object.
SPI interface	SCK. Use SPI1 object.
Supports attachInterrupt	Yes
Internal pull resistance	???
MCU Pin	PA[14]
M.2 connector pin number	42

D3

Details

Pin Name	D3
Description	D3 GPIO, Serial CTS flow control (optional), SPI SS
Supports digitalRead	Yes
Supports digitalWrite	Yes
UART serial	CTS. Use Serial1 object.
SPI interface	SS. Use SPI1 object.
Supports attachInterrupt	Yes
Internal pull resistance	???
MCU Pin	PA[15]
M.2 connector pin number	40

D4

Details

Pin Name	D4
Description	D4 GPIO, PWM
Supports digitalRead	Yes
Supports digitalWrite	Yes
Supports analogWrite (PWM)	Yes
Supports tone	Yes

Supports attachInterrupt	Yes
Internal pull resistance	???
MCU Pin	PB[18]
M.2 connector pin number	66

D5

Details

Pin Name	D5
Description	D5 GPIO, PWM, I2S TX
Supports digitalRead	Yes
Supports digitalWrite	Yes
Supports analogWrite (PWM)	Yes
Supports tone	Yes
Supports attachInterrupt	Yes
I2S interface	I2S TX
Internal pull resistance	???
MCU Pin	PB[19]
M.2 connector pin number	68

D6

Details

Pin Name	D6
Description	D6 GPIO, PWM, I2S CLK
Supports digitalRead	Yes
Supports digitalWrite	Yes
Supports analogWrite (PWM)	Yes
Supports tone	Yes
I2C interface	SCL. Use Wire1 object. Use 1.5K to 10K external pull-up resistor.
Supports attachInterrupt	Yes
I2S interface	I2S CLK
Internal pull resistance	???
MCU Pin	PB[20]
M.2 connector pin number	70

D20

Details

Pin Name	D20
Description	D20 GPIO, I2S TX
Supports digitalRead	Yes
Supports digitalWrite	Yes
Supports attachInterrupt	Yes
I2S interface	I2S TX
Internal pull resistance	???
MCU Pin	PA[1]
M.2 connector pin number	19

D21**Details**

Pin Name	D21
Description	D21 GPIO, I2S RX
Supports digitalRead	Yes
Supports digitalWrite	Yes
Supports attachInterrupt	Yes
I2S interface	I2S RX
Internal pull resistance	22K. No internal pull up or pull down in HIBERNATE sleep mode.
MCU Pin	PA[0]
M.2 connector pin number	17

D22**Details**

Pin Name	D22
Description	D22 GPIO
Internal pull resistance	???
MCU Pin	PA[9]
M.2 connector pin number	62

D24**Details**

Pin Name	D24
Description	D24 GPIO, Serial2 TX, do not pull down at boot
Supports digitalRead	Yes
Supports digitalWrite	Yes
UART serial	TX. Use Serial2 object.
Supports attachInterrupt	Yes
Internal pull resistance	42K
Signal used at boot	Low at boot triggers ISP flash download
MCU Pin	PA[7]
M.2 connector pin number	58

D25**Details**

Pin Name	D25
Description	GPIO25, Serial2 RX
Supports digitalRead	Yes
Supports digitalWrite	Yes
UART serial	RX. Use Serial2 object.
Supports attachInterrupt	Yes
Internal pull resistance	42K
Signal used at boot	Goes high at boot
MCU Pin	PA[8]
M.2 connector pin number	60

D26

Details

Pin Name	D26
Description	D26 GPIO, I2S WS
Supports digitalRead	Yes
Supports digitalWrite	Yes
Supports attachInterrupt	Yes
I2S interface	I2S WS
Internal pull resistance	???
MCU Pin	PA[4]
M.2 connector pin number	59

D27

Details

Pin Name	D27
Description	D27 GPIO, SWDIO (SWD_DATA), do not pull down at boot
Internal pull resistance	42K
SWD interface	SWDIO. 40K pull-up at boot.
Signal used at boot	SWDIO. 40K pull-up at boot. Low at boot triggers MCU test mode.
MCU Pin	PA[27]
M.2 connector pin number	55

GND

Details

Pin Name	GND
Description	Ground

IOEX_PA0

Details

Pin Name	IOEX_PA0
Supports digitalRead	Yes
Supports digitalWrite	Yes

IOEX_PB7

Details

Pin Name	IOEX_PB7
Supports digitalRead	Yes
Supports digitalWrite	Yes

MISO

Details

Pin Name	MISO
Pin Alternate Name	D11
Description	D11 GPIO, PWM, SPI MISO
Supports analogWrite (PWM)	Yes

Supports tone	Yes
SPI interface	MISO. Use SPI object.
Internal pull resistance	2.1K
MCU Pin	PA[17]
M.2 connector pin number	50

MOSI

Details

Pin Name	MOSI
Pin Alternate Name	D12
Description	D12 GPIO, PWM, SPI MOSI
Supports analogWrite (PWM)	Yes
Supports tone	Yes
SPI interface	MOSI. Use SPI object.
Internal pull resistance	2.1K
MCU Pin	PA[16]
M.2 connector pin number	52

NC27

Details

Pin Name NC27

NC28

Details

Pin Name NC28

RX

Details

Pin Name	RX
Pin Alternate Name	D10
Description	Serial RX, PWM, GPIO, SPI1 MISO
Supports digitalRead	Yes
Supports digitalWrite	Yes
Supports analogWrite (PWM)	Yes
Supports tone	Yes
UART serial	RX. Use Serial1 object.
SPI interface	MISO. Use SPI1 object.
Supports attachInterrupt	Yes
Internal pull resistance	2.1K
MCU Pin	PA[13]
M.2 connector pin number	38

SCK

Details

Pin Name SCK

Pin Alternate Name	D13
Description	D13 GPIO, SPI SCK
SPI interface	SCK. Use SPI object.
Internal pull resistance	2.1K
MCU Pin	PA[18]
M.2 connector pin number	54

TX

Details

Pin Name	TX
Pin Alternate Name	D9
Description	Serial TX, PWM, GPIO, SPI1 MOSI, I2S MCLK
Supports digitalRead	Yes
Supports digitalWrite	Yes
Supports analogWrite (PWM)	Yes
Supports tone	Yes
UART serial	TX. Use Serial1 object.
SPI interface	MOSI. Use SPI1 object.
Supports attachInterrupt	Yes
I2S interface	I2S MCLK
Internal pull resistance	2.1K
MCU Pin	PA[12]
M.2 connector pin number	36

{{!--

Mechanical specifications

DIMENSIONS AND WEIGHT

To be provided at a later date.

MECHANICAL DRAWING

To be provided at a later date. --}}

Schematics

SCHEMATICS PAGE 2

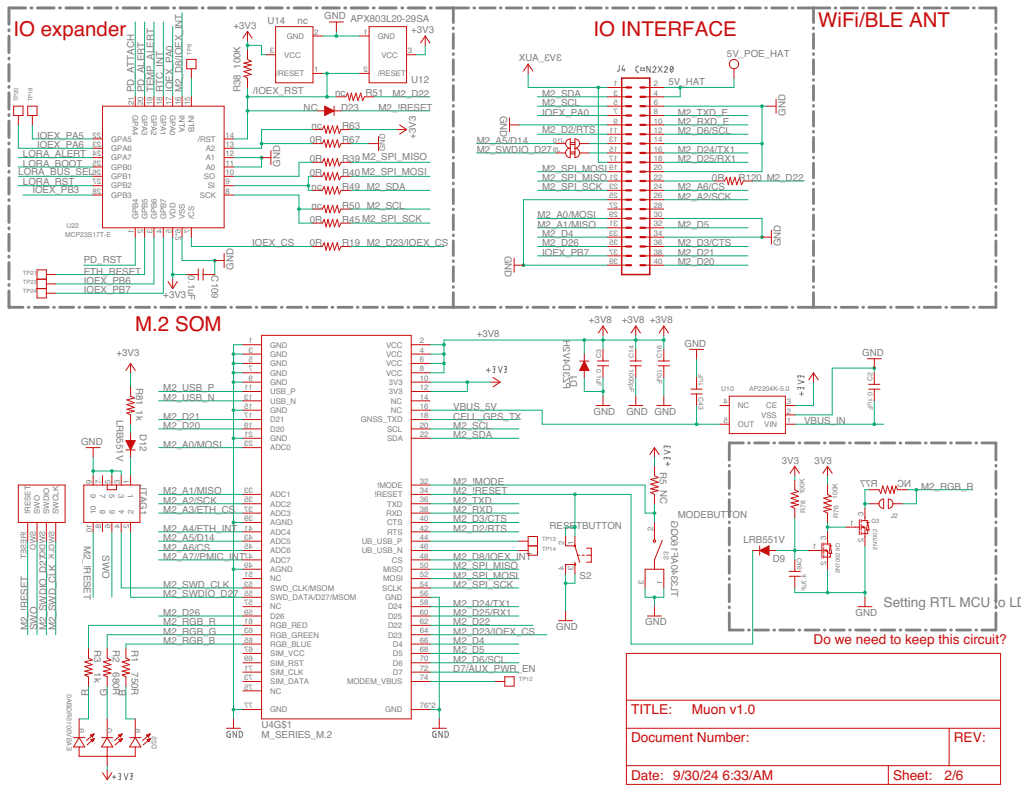

SCHEMATICS PAGE 3

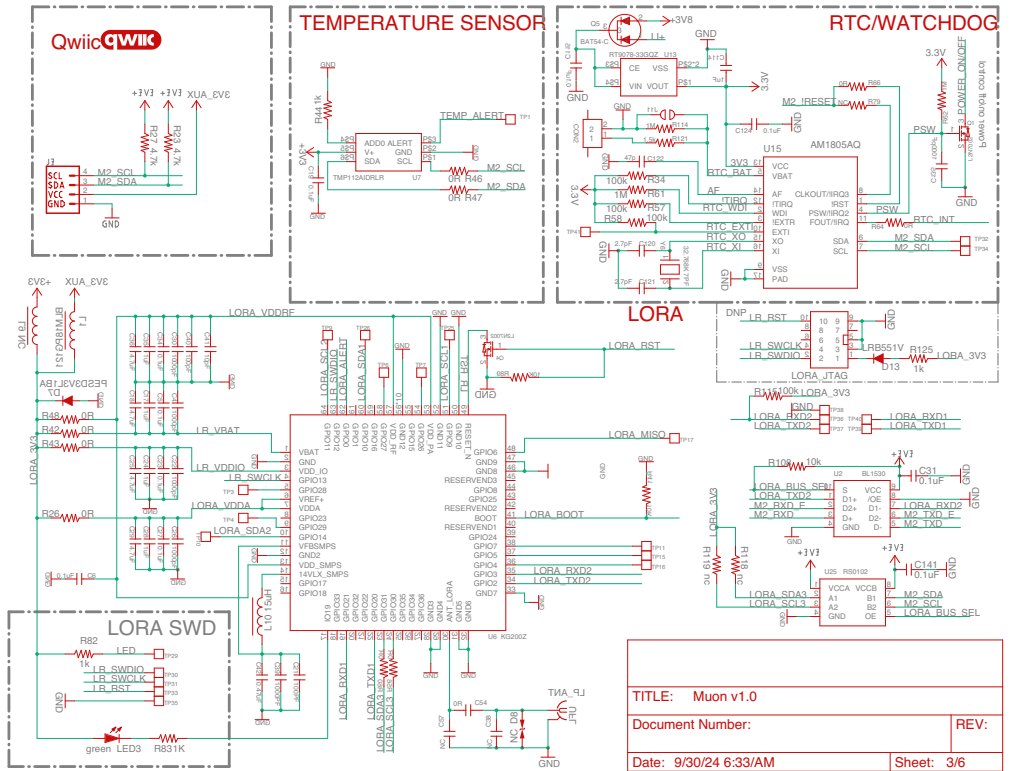

SCHEMATICS PAGE 4

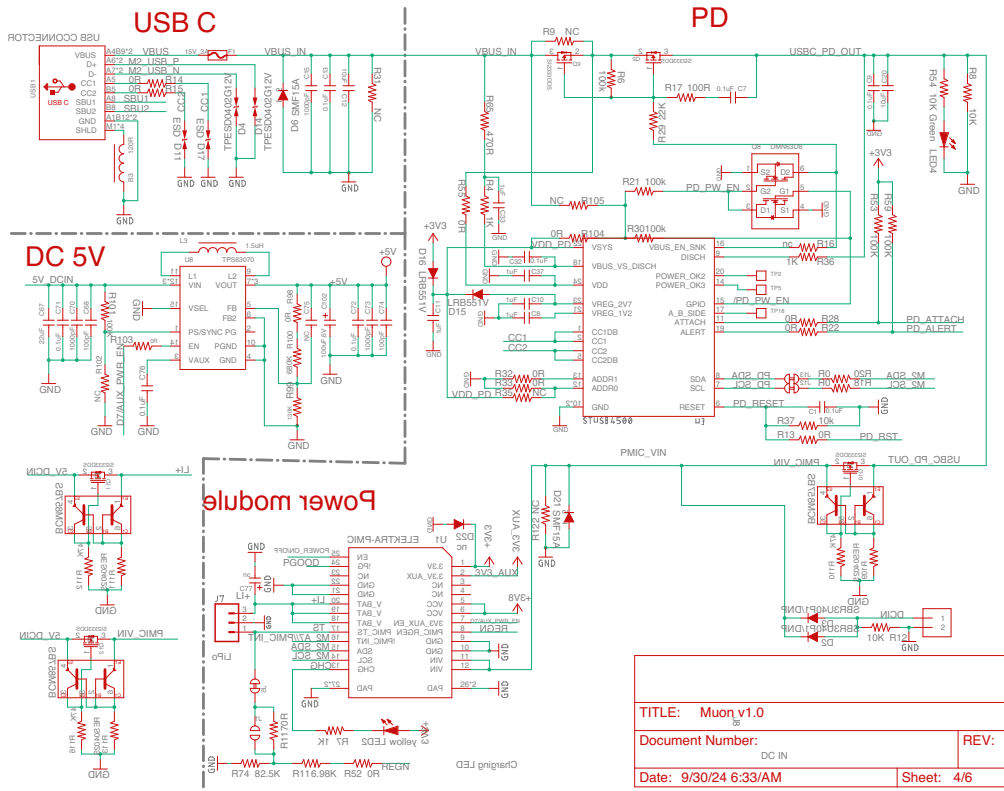

SCHEMATICS PAGE 5

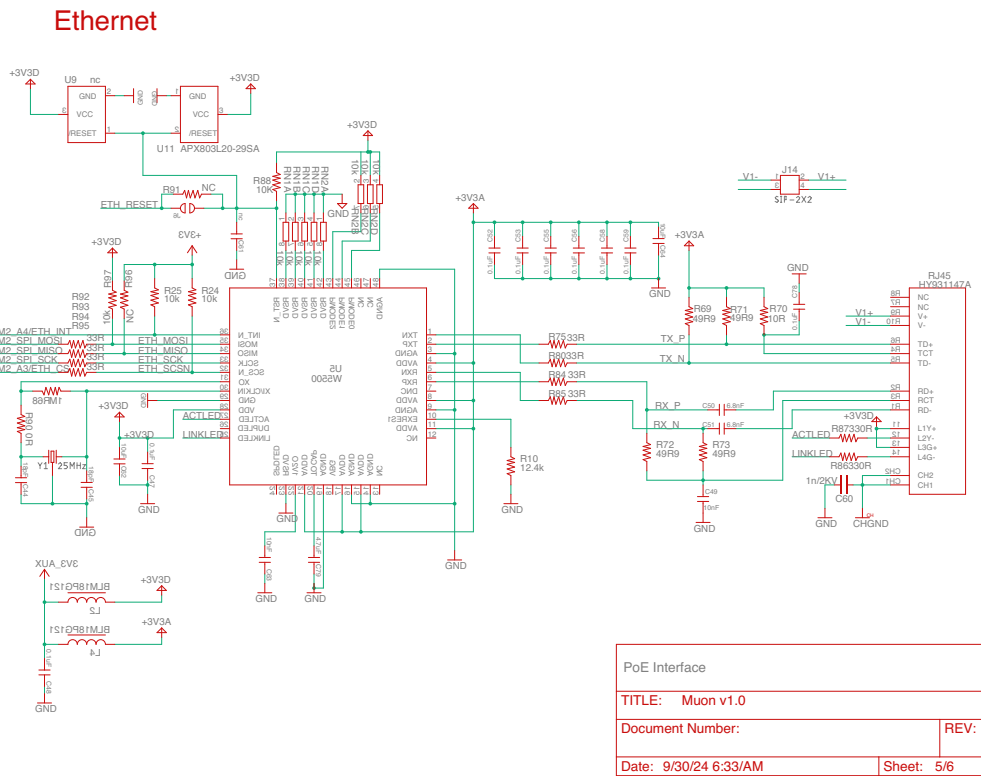

SCHEMATICS PAGE 6

HAT_5V <-> muon 5V bidirectional power conversion circuit

Circuit 1

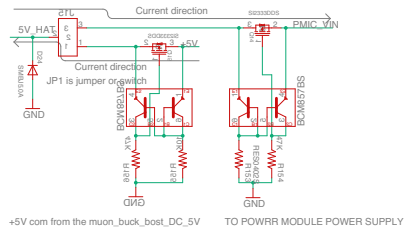

TITLE: Muon v1.0	
Document Number:	REV:
Date: 9/30/24 6:33/AM	Sheet: 6/6

Product Handling

ESD PRECAUTIONS

The M-SoM contains highly sensitive electronic circuitry and is an Electrostatic Sensitive Device (ESD). Handling an M-SoM without proper ESD protection may destroy or damage it permanently. Proper ESD handling and packaging procedures must be applied throughout the processing, handling and operation of any application that incorporates the Particle M-SoM. ESD precautions should be implemented on the application board where the M-SoM is mounted. Failure to observe these precautions can result in severe damage to the M-SoM!

CONNECTORS

The U.FL antenna connector is not designed to be constantly plugged and unplugged. The antenna pin is static sensitive and you can destroy the radio with improper handling. A tiny dab of glue (epoxy, rubber cement, liquid tape or hot glue) on the connector can be used securely hold the plug in place.

The M.2 edge connector is static sensitive and should be handled carefully. The M.2 connector is not designed for repeated removal and insertion of the module.

Default settings

The M-SoM comes pre-programmed with a bootloader and a user application called Tinker. This application works with an iOS and Android app also named Tinker that allows you to very easily toggle digital pins, take analog and digital readings and drive variable PWM outputs.

The bootloader allows you to easily update the user application via several different methods, USB, OTA, Serial Y-Modem, and also internally via the Factory Reset procedure. All of these methods have multiple tools associated with them as well.

FCC ISED CE Warnings and End Product Labeling Requirements

Federal Communication Commission Interference Statement This equipment has been tested and found to comply with the limits for a Class B digital device, pursuant to Part 15 of the FCC Rules. These limits are designed to provide reasonable protection against harmful interference in a residential installation. This equipment generates, uses and can radiate radio frequency energy and, if not installed and used in accordance with the instructions, may cause harmful interference to radio communications. However, there is no guarantee that interference will not occur in a particular installation. If this equipment does cause harmful interference to radio or television reception, which can be determined by turning the equipment off and on, the user is encouraged to try to correct the interference by one of the following measures:

- Reorient or relocate the receiving antenna.
- Increase the separation between the equipment and receiver.
- Connect the equipment into an outlet on a circuit different from that to which the receiver is connected.
- Consult the dealer or an experienced radio/TV technician for help.

FCC Caution: Any changes or modifications not expressly approved by the party responsible for compliance could void the user's authority to operate this equipment. This device complies with Part 15 of the FCC Rules. Operation is subject to the following two conditions:

1. This device may not cause harmful interference, and
2. This device must accept any interference received, including interference that may cause undesired operation.

FCC Radiation Exposure Statement: This equipment complies with FCC radiation exposure limits set forth for an uncontrolled environment. This transmitter module must not be co-located or operating in conjunction with any other antenna or transmitter. This End equipment should be installed and operated with a minimum distance of 20 centimeters between the radiator and your body.

IMPORTANT NOTE: In the event that these conditions can not be met (for example certain laptop configurations or co-location with another transmitter), then the FCC authorization is no longer considered valid and the FCC ID can not be used on the final product. In these circumstances, the OEM integrator will be responsible for re-evaluating the end product (including the transmitter) and obtaining a separate FCC authorization.

End Product Labeling The final end product must be labeled in a visible area with the following:

- Contains FCC ID: xxx

Manual Information to the End User The OEM integrator has to be aware not to provide information to the end user regarding how to install or remove this RF module in the user's manual of the end product which integrates this module.

Outdoor Use (US)

To be compliant to FCC §15.407(a) the EIRP is not allowed to exceed 125 mW (21 dBm) at any elevation angle above 30° (measured from the horizon) when operated as an outdoor access point in U-NII-1 band, 5.150-5.250 GHz.

Canada Statement This device complies with Industry Canada's licence-exempt RSSs. Operation is subject to the following two conditions:

1. This device may not cause interference; and
2. This device must accept any interference, including interference that may cause undesired operation of the device.

Le présent appareil est conforme aux CNR d'Industrie Canada applicables aux appareils radio exempts de licence.

L'exploitation est autorisée aux deux conditions suivantes:

1. l'appareil ne doit pas produire de brouillage;
2. l'utilisateur de l'appareil doit accepter tout brouillage radioélectrique subi, même si le brouillage est susceptible d'en compromettre le fonctionnement.

Caution Exposure: This device meets the exemption from the routine evaluation limits in section 2.5 of RSS102 and users can obtain Canadian information on RF exposure and compliance. Le dispositif répond à l'exemption des limites d'évaluation de routine dans la section 2.5 de RSS102 et les utilisateurs peuvent obtenir des renseignements canadiens sur l'exposition aux RF et le respect.

The final end product must be labelled in a visible area with the following: The Industry Canada certification label of a module shall be clearly visible at all times when installed in the host device, otherwise the host device must be labelled to display the Industry Canada certification number of the module, preceded by the words "Contains transmitter module", or the word "Contains", or similar wording expressing the same meaning, as follows:

- Contains transmitter module ISED: 20127-M524

This End equipment should be installed and operated with a minimum distance of 20 centimeters between the radiator and your body. Cet équipement devrait être installé et actionné avec une distance minimum de 20 centimètres entre le radiateur et votre corps.

The end user manual shall include all required regulatory information/warning as shown in this manual.

Outdoor use (CA)

- Operation in the band 5150–5250 MHz is only for indoor use to reduce the potential for harmful interference to co-channel mobile satellite systems;
- Operation in the 5600-5650 MHz band is not allowed in Canada. High-power radars are allocated as primary users (i.e., priority users) of the bands 5250-5350 MHz and 5650-5850 MHz and that these radars could cause interference and/or damage to LE-LAN devices.

- Le dispositif de fonctionnement dans la bande 5150-5250 MHz est réservé à une utilisation en intérieur pour réduire le risque d'interférences nuisibles à la co-canal systèmes mobiles par satellite
- Opération dans la bande 5600-5650 MHz n'est pas autorisée au Canada. Haute puissance radars sont désignés comme utilisateurs principaux (c.-à-utilisateurs prioritaires) des bandes 5250-5350 MHz et 5650-5850 MHz et que ces radars pourraient causer des interférences et / ou des dommages à dispositifs LAN-EL.

EUROPEAN UNION (CE)

We, Particle Industries, Inc, declare under our sole responsibility that the product, P2, to which this declaration relates, is in conformity with RED Directive 2014/53/EU and (EU) 2015/863 RoHS Directive 2011/65/EU (Recast).

The full text of the EU declaration of conformity is available at the following Internet address:

<https://www.particle.io/>

Radiation Exposure Statement: This equipment complies with radiation exposure limits set forth for an uncontrolled environment.

The operating frequency bands and the maximum transmitted power limit are listed below:

- BLE 2402-2480MHz 10dBm
- Wi-Fi 2.4GHz band 2412-2484MHz 20dBm
- Wi-Fi 5GHz band 5180-5825MHz 23dBm

UNITED KINGDOM

UKCA Conformity:

Radio Equipment Regulations 2017 (S.I. 2017/1206)

OUTDOOR USE (WORLD)

This device is restricted to indoor use when operating in the 5150 to 5350 MHz frequency range.

This restriction applies in: AT, BE, BG, CH, CY, CZ, DE, DK, EE, EL, ES, FI, FR, HR, HU, IE, IS, IT, LI, LT, LU, LV, MT, NL, NO, PL, PT, RO, SE, SI, SK, TR, UA, UK(NI).

MUON404 - COUNTRY COMPATIBILITY

Country	Model	Technologies	Carriers
Canada	M404	M1	Bell Mobility, Rogers Wireless, Telus
Mexico	M404	2G, M1	AT&T, Telcel
United States	M404	2G, M1	Alaska Wireless, AT&T, T-Mobile (USA), Verizon ⁷

The M404 is fully supported in the United States, Canada, and Mexico. It is in beta testing in other locations. See the [carrier list](#) for country compatibility information.

MUON404 - CERTIFIED BANDS

Technology	Band	FCC	CE
2G	850 MHz	✓	
2G	900 MHz		
2G	1800 MHz		
2G	1900 MHz	✓	
LTE Cat M1	B1 (2100 MHz)		✓
LTE Cat M1	B2 (1900 MHz)	✓	
LTE Cat M1	B3 (1800 MHz)		✓
LTE Cat M1	B4 (1700 MHz)	✓	
LTE Cat M1	B5 (850 MHz)	✓	
LTE Cat M1	B8 (900 MHz)		✓
LTE Cat M1	B12 (700 MHz)	✓	
LTE Cat M1	B13 (700 MHz)	✓	
LTE Cat M1	B20 (800 MHz)		✓
LTE Cat M1	B25 (1900 MHz)	✓	
LTE Cat M1	B26 (850 MHz)	✓	
LTE Cat M1	B28 (700 MHz)		✓
LTE Cat M1	B66 (2100 MHz)	✓	

MUON524 - COUNTRY COMPATIBILITY

Country	Model	Technologies	Carriers
Albania	M524	2G, 3G, Cat1	ALBtelecom, Telekom, Vodafone
Algeria	M524	2G, 3G, Cat1	Mobilis, Ooredoo
Aruba	M524	2G, 3G, Cat1	Setar
Australia	M524	Cat1	Optus, Telstra, Vodafone
Austria	M524	2G, 3G, Cat1	3 (Drei), A1, T-Mobile
Bahrain	M524	2G, 3G, Cat1	Zain
Bangladesh	M524	2G, 3G, Cat1	Bangalink, GrameenPhone
Belarus	M524	2G, 3G, Cat1	A1
Belgium	M524	2G, 3G, Cat1	Base, Orange, Proximus
Bosnia and Herzegovina	M524	2G, 3G	BH Telecom, HT Eronet
Botswana	M524	2G, 3G, Cat1	BeMobile
Brunei	M524	3G, Cat1	DST
Bulgaria	M524	2G, 3G	A1, Telenor, Vivacom
Burkina Faso	M524	2G, 3G, Cat1	Orange

Cabo Verde	M524	2G, 3G, Cat1	CVMóvel, Unitel T+
Cambodia	M524	2G, 3G	Metfone
Chad	M524	2G, 3G, Cat1	Airtel
Chile	M524	2G, 3G, Cat1	Claro, Entel, Movistar
Congo (Brazzaville)	M524	2G, 3G, Cat1	Airtel
Congo (Kinshasa)	M524	2G, 3G, Cat1	Airtel
Côte d'Ivoire	M524	2G, 3G, Cat1	MTN
Croatia	M524	2G, 3G, Cat1	Hrvatski Telekom, Tele2
Cyprus	M524	2G, 3G, Cat1	Cytamobile-Vodafone, MTN, PrimeTel
Czechia	M524	2G, Cat1	O2, T-Mobile, Vodafone
Denmark	M524	2G, 3G, Cat1	3 (Tre), TDC, Telenor, Telia
Egypt	M524	2G, 3G, Cat1	Etisalat, Orange
Estonia	M524	2G, 3G, Cat1	Elisa, Tele2, Telia
eSwatini	M524	2G, 3G, Cat1	MTN
Ethiopia	M524	2G, 3G, Cat1	Ethio Telecom
Faroe Islands	M524	2G, 3G	Faroese Telecom, Vodafone
Finland	M524	2G, Cat1	DNA, Elisa, Telia
France	M524	2G, 3G, Cat1	Bouygues, Free Mobile, Orange, SFR
French Guiana	M524	2G, 3G	Digicel
Gabon	M524	2G, 3G, Cat1	Airtel
Germany	M524	2G, 3G, Cat1	O2, Telekom, Vodafone
Ghana	M524	2G, 3G, Cat1	AirtelTigo, MTN, Vodafone
Gibraltar	M524	2G, 3G, Cat1	Gibtel
Greece	M524	2G, Cat1	Cosmote, Vodafone, Wind
Guinea	M524	2G, 3G, Cat1	MTN
Guinea-Bissau	M524	2G, 3G, Cat1	MTN
Guyana	M524	2G	Digicel
Hong Kong	M524	2G, 3G, Cat1	CMHK, CSL, SmarTone
Hungary	M524	2G, 3G, Cat1	Magyar Telekom, Telenor, Vodafone
Iceland	M524	2G, 3G, Cat1	Nova, Siminn, Vodafone
Indonesia	M524	2G, 3G, Cat1	Indosat, Telkomsel, XL Axiata
Ireland	M524	2G, 3G, Cat1	3 (Tre), Meteor, O2, Vodafone
Israel	M524	2G, 3G, Cat1	Hot Mobile, Orange, Pelephone
Italy	M524	2G, 3G, Cat1	TIM, Vodafone, Wind
Jordan	M524	2G, 3G, Cat1	Zain
Kazakhstan	M524	2G, 3G, Cat1	Beeline, K-Cell
Kenya	M524	2G, 3G, Cat1	Airtel
Kuwait	M524	2G, 3G, Cat1	Viva, Zain
Latvia	M524	2G, 3G, Cat1	Bite, LMT, Tele2
Liechtenstein	M524	2G, 3G, Cat1	Mobilkom, Orange
Lithuania	M524	2G, 3G, Cat1	Bite, Omnitel, Tele2
Luxembourg	M524	2G, 3G, Cat1	Orange, POST, Tango
Macao	M524	2G, 3G, Cat1	CTM
Madagascar	M524	2G, 3G, Cat1	Airtel
Malawi	M524	2G, 3G, Cat1	Airtel

Malaysia	M524	2G, 3G, Cat1	Celcom, DiGi, Maxis
Malta	M524	2G, 3G, Cat1	Go Mobile, Vodafone
Moldova	M524	2G, 3G, Cat1	Moldcell, Orange
Mongolia	M524	2G, 3G	Mobicom, Unitel
Montenegro	M524	2G, 3G, Cat1	Mtel, T-Mobile, Telenor
Morocco	M524	2G, 3G, Cat1	Inwi, Medi Telecom
Mozambique	M524	2G, 3G, Cat1	Vodacom
Myanmar	M524	2G, 3G, Cat1	MPT, Telenor
Namibia	M524	2G, 3G, Cat1	Telecom Namibia
Netherlands	M524	2G, 3G, Cat1	KPN, T-Mobile, Vodafone
New Zealand	M524	2G, 3G, Cat1	2degrees, Spark, Vodafone
Nigeria	M524	2G, 3G, Cat1	9mobile, Airtel, Glo, MTN
Norway	M524	2G, 3G, Cat1	TDC, Telenor, Telia
Pakistan	M524	2G, 3G, Cat1	Mobilink, Telenor, Ufone, Warid
Palestine	M524	2G, 3G	Jawwal
Papua New Guinea	M524	2G, 3G	bmobile
Poland	M524	2G, 3G, Cat1	Orange, Play, Plus, T-Mobile
Portugal	M524	2G, 3G, Cat1	NOS, TMN, Vodafone
Qatar	M524	2G, 3G, Cat1	Ooredoo, Vodafone
Romania	M524	2G, 3G, Cat1	Orange, Telekom Romania, Vodafone
Rwanda	M524	2G, 3G, Cat1	Airtel, MTN
Serbia	M524	2G, 3G, Cat1	Telenor, VIP
Seychelles	M524	2G, 3G, Cat1	Airtel
Sint Maarten	M524	2G, 3G, Cat1	TelCell
Slovakia	M524	2G, 3G, Cat1	O2, Orange, Telekom
Slovenia	M524	2G, 3G, Cat1	A1, Mobitel
South Africa	M524	2G, 3G, Cat1	Cell C, MTN, Vodacom
South Korea	M524	3G, Cat1	KT, LG U+, SK Telecom
South Sudan	M524	2G, 3G, Cat1	MTN
Spain	M524	2G, 3G, Cat1	Orange, Telefonica, Vodafone, Yoigo
Sri Lanka	M524	2G, 3G, Cat1	Dialog, Mobitel
Suriname	M524	2G, 3G	Telesur
Sweden	M524	2G, 3G, Cat1	3 (Tre), Tele2, Telenor, Telia
Switzerland	M524	3G, Cat1	Salt, Sunrise, Swisscom
Taiwan	M524	3G, Cat1	Chunghwa, FarEasTone, T Star, Taiwan Mobile
Tanzania	M524	2G, 3G, Cat1	Airtel
Thailand	M524	2G, 3G, Cat1	AIS, DTAC, True Move
Tunisia	M524	2G, 3G, Cat1	Orange Tunisie, Tunisie Telecom
Uganda	M524	2G, 3G, Cat1	Africell, Airtel, MTN
United Kingdom	M524	2G, 3G, Cat1	3, EE, Manx, O2, Sure, Vodafone
Vietnam	M524	2G, 3G, Cat1	MobiFone, Viettel, Vinaphone
Zambia	M524	2G, 3G, Cat1	Airtel

MUON524 - CERTIFIED BANDS

Technology Band CE

2G	900 MHz	✓
2G	1800 MHz	✓
3G	B1 (2100 MHz)	✓
3G	B8 (900 MHz)	✓
LTE Cat 1	B1 (2100 MHz)	✓
LTE Cat 1	B3 (1800 MHz)	✓
LTE Cat 1	B7 (2600 MHz)	✓
LTE Cat 1	B8 (900 MHz)	✓
LTE Cat 1	B20 (800 MHz)	✓
LTE Cat 1	B28 (700 MHz)	✓

MUON635 - COUNTRY COMPATIBILITY

Global, country list to be provided a later date.

Ordering information

SKU	Description	Region	Modem	EtherSIM	Lifecycle	Replacement
MUON404EA	Muon LTE-M/2G Kit (Global, EtherSIM), [x1]	Global	BG95-M5	✓	In development	
MUON404KIT	Muon LTE M1/2G Kit (Global, EtherSIM), [x1]	Global	BG95-M5	✓	In development	
MUON524EA	Muon LTE CAT1/3G/2G Kit (Europe, EtherSIM), [x1]	Global	EG91-EX	✓	In development	
MUON524KIT	Muon LTE CAT1/3G/2G Kit (Europe, EtherSIM), [x1]	Global	EG91-EX	✓	In development	
MUON635EA	Muon LTE M1/2G/Satellite Kit (Global, EtherSIM), [x1]	Global	BG95-S5	✓	In development	
MUON635KIT	Muon LTE M1/2G/Satellite Kit (Global, EtherSIM), [x1]	Global	BG95-S5	✓	In development	

- EMEAA: Selected countries in Europe, Middle East, Africa, and Asia, including Australia and New Zealand. See the [cellular carrier list](#) for more information.

Revision history

Revision	Date	Author	Comments
pre	2024-02-05	RK	Preliminary version (schematic 0.02 20240203R6)
	2024-04-22	RK	Update for schematic 0.3
	2024-04-24	RK	Update for schematic 0.3R2
	2024-04-24	RK	Expansion card interface updates
	2024-05-08	RK	Update for schematic 0.4R2
	2024-05-14	RK	Update for schematic 0.4R4
	2024-05-20	RK	Update diagrams 0.4R4
	2024-08-04	RK	Pinmap 0.05
	2024-09-24	RK	Removed concurrent GNSS warning, added link to library
1	2024-10-08	RK	Update for schematic v1.0
2	2024-10-22	RK	Public release

Ordering information

SKU	Description	Region	Modem	EtherSIM	Lifecycle	Replacement
MUON404EA	Muon LTE-M/2G Kit (Global, EtherSIM), [x1]	Global	BG95-M5	✓	In development	
MUON404KIT	Muon LTE M1/2G Kit (Global, EtherSIM), [x1]	Global	BG95-M5	✓	In development	
MUON524EA	Muon LTE CAT1/3G/2G Kit (Europe, EtherSIM), [x1]	Global	EG91-EX	✓	In development	
MUON524KIT	Muon LTE CAT1/3G/2G Kit (Europe, EtherSIM), [x1]	Global	EG91-EX	✓	In development	
MUON635EA	Muon LTE M1/2G/Satellite Kit (Global, EtherSIM), [x1]	Global	BG95-S5	✓	In development	
MUON635KIT	Muon LTE M1/2G/Satellite Kit (Global, EtherSIM), [x1]	Global	BG95-S5	✓	In development	

- EMEAA: Selected countries in Europe, Middle East, Africa, and Asia, including Australia and New Zealand. See the [cellular carrier list](#) for more information.