



BUREAU
VERITAS

Test Report No.: RE2312WDG0147-6



Certificate # 2951.01

TEST REPORT



Applicant	Particle Industries, Inc
Address	325 9th St, San Francisco, CA 94103 USA, 415-319-1553

Manufacturer or Supplier	Particle Industries, Inc
Address	325 9th St, San Francisco, CA 94103 USA, 415-319-1553
Product	M SoM
Brand Name	Particle
Model	M404
Additional Model & Model Difference	N/A
Date of tests	Jan. 11, 2024 ~ Feb. 23, 2024

The submitted sample of the above equipment has been tested according to the requirements of the following standard:

EN 303 413 V1.2.1 (2021-04)

CONCLUSION: The submitted sample was found to COMPLY with the test requirement

Tested by Lucas Chen Project Engineer / EMC Department	Approved by Glyn He Assistant Manager / EMC Department
	
	Date: Mar. 14, 2024

This report is governed by, and incorporates by reference, the Conditions of Testing as posted at the date of issuance of this report at <http://www.bureauveritas.com/home/about-us/our-business/cps/about-us/terms-conditions/>, and is intended for your exclusive use. Any copying or replication of this report to or for any other person or entity, or use of our name or trademark, is permitted only with our prior written permission. This report sets forth our findings solely with respect to the test samples identified herein. The results set forth in this report are not indicative or representative of the quality or characteristics of the lot from which a test sample was taken or any similar or identical product unless specifically and expressly noted. Our report includes all of the tests requested by you and the results thereof based upon the information that you provided to us. Measurement uncertainty is only provided upon request for accredited tests. Statements of conformity are based on simple acceptance criteria without taking measurement uncertainty into account, unless otherwise requested in writing. You have 60 days from date of issuance of this report to notify us of any material error or omission caused by our negligence or if you require measurement uncertainty; provided, however, that such notice shall be in writing and shall specifically address the issue you wish to raise. A failure to raise such issue within the prescribed time shall constitute your unqualified acceptance of the completeness of this report, the tests conducted and the correctness of the report contents.

Bureau Veritas Shenzhen Co.,
Ltd. Dongguan Branch

No. 96, Guantai Road (Houjie Section), Houjie Town,
Dongguan City, Guangdong Province. 523942. People's
Republic of China.

Tel.: +86 769 8998 2098
Fax: +86 769 8593 1080
Email: customerservice.dg@bureauveritas.com



TABLE OF CONTENTS

RELEASE CONTROL RECORD 3

1 SUMMARY OF TEST RESULTS 4

 1.1 MEASUREMENT UNCERTAINTY 4

2 GENERAL INFORMATION 5

 2.1 GENERAL DESCRIPTION OF EUT 5

 2.2 DESCRIPTION OF TEST MODES 6

 2.2.1 TEST MODE APPLICABILITY AND TESTED DETAIL 6

 2.3 DESCRIPTION OF SUPPORT UNITS 9

 2.4 TEST INSTRUMENTS 9

 2.5 TEST PROCEDURE AND RESULTS 10

 2.6 GENERAL DESCRIPTION OF APPLIED STANDARDS 10

3 TEST PROCEDURE AND RESULTS 11

 3.1 RECEIVER BLOCKING 11

 3.1.1 CONFORMANCE SPECIFICATIONS 11

 3.1.2 TEST PROCEDURES 11

 3.1.3 DEVIATION FROM TEST STANDARD 11

 3.1.4 TEST SETUP 11

 3.1.5 TEST RESULTS 12

 3.2 RECEIVER SPURIOUS EMISSIONS 14

 3.2.1 LIMIT OF RECEIVER SPURIOUS RADIATION 14

 3.2.2 TEST PROCEDURE 14

 3.2.3 DEVIATION FROM TEST STANDARD 14

 3.2.4 TEST SETUP 14

 3.2.5 TEST RESULTS 15

4 PHOTOGRAPHS OF THE TEST CONFIGURATION 18

5 APPENDIX A – MODIFICATIONS RECORDERS FOR ENGINEERING CHANGES TO THE EUT BY THE LAB 20



BUREAU
VERITAS

Test Report No.: RE2312WDG0147-6

RELEASE CONTROL RECORD

ISSUE NO.	REASON FOR CHANGE	DATE ISSUED
RE2312WDG0147-6	Original release	Mar. 14, 2024



1 SUMMARY OF TEST RESULTS

The EUT has been tested according to the following specifications:

EN 303 413 V1.2.1		
Clause	Test Parameter	Results
4.2.1	Receiver blocking	Pass
4.2.2	Spurious domain	Pass

1.1 MEASUREMENT UNCERTAINTY

Where relevant, the following measurement uncertainty levels have been estimated for tests performed on the EUT:

This uncertainty represents an expanded uncertainty expressed at approximately the 95% confidence level using a coverage factor of $k=2$.

Parameter	Uncertainty
Uncertainty in conducted measurements	± 2.855 dB
Uncertainty in radiated measurements	± 2.855 dB
Spurious emissions	± 2.855 dB

Note: Referenced documents ETSI EN 300 328 standards.



2 GENERAL INFORMATION

2.1 GENERAL DESCRIPTION OF EUT

PRODUCT	M SoM	
BRAND	Particle	
TEST MODEL	M404	
ADDITIONAL MODEL	N/A	
NOMINAL VOLTAGE	VCC: 3.8V. 3V3:3.3V	
REGULATORY TYPE	GPS, GALILEO, BDS, GLONASS,	
MODULATION TECHNOLOGY	GPS	CDMA
	GLONASS	FDMA
	BDS	CDMA
	GALILEO	CDMA
MODULATION TYPE	GPS	BPSK
	GLONASS	BPSK
	BDS	BPSK
	GALILEO	CBOC
OPERATING FREQUENCY	GLONASS	1602 MHz + n × 0.5625 MHz ("n" is a satellite's frequency channel number from -7 ~ 13)
	GPS	1575.42 MHz±1.023 MHz
	BDS	1561.098 MHz±2.046 MHz
	GALILEO	1575.42 MHz ± 1.023 MHz
ANTENNA TYPE	FPCB Antenna, 3.9dBi Gain	
VERSION OF HARDWARE	N/A	
VERSION OF SOFTWARE	BG95M5LAR02A03	
CABLE SUPPLIED	N/A	

Notes:

1. The above EUT information is declared by manufacturer and for more detailed features description, please refer to the manufacturer's specifications or user's manual.
2. For the test results, the EUT had been tested with all conditions, but only the worst case was shown in test report.
3. Please refer to the EUT photo document (Reference No.: W7L-P23120015) for detailed product photo.



2.2 DESCRIPTION OF TEST MODES

GNSS are provided for GPS, GLONASS, BDS and GALILEO:

GNSS	RNSS FREQUENCY
GLONASS	1605.375 MHz
GPS	1575.42 MHz
BDS	1561.098 MHz
GALILEO	1575.42 MHz

2.2.1 TEST MODE APPLICABILITY AND TESTED DETAIL

EUT Configure Mode	Applicable to			Description
	RB	SE<1G	SE≥1G	
GLONASS/ GPS/ BDS /GALILEO	√	√	√	-

Where **RB**: Receiver blocking

SE<1G: Unwanted Emissions in the Spurious Domain below 1 GHz

SE≥1G: Unwanted Emissions in the Spurious Domain above 1 GHz

NOTE: 1. The EUT had been pre-tested on the positioned of each 3 axes. The worst case was found when positioned on X-plane.

RECEIVER BLOCKING:

Following Supported GNSS(s) was (were) selected for the final test as listed below.

GNSS	GNSS Signals			
BDS	<input checked="" type="checkbox"/> B1I	<input type="checkbox"/> B1C		
Galileo	<input checked="" type="checkbox"/> E1	<input type="checkbox"/> E5a	<input type="checkbox"/> E5b	<input type="checkbox"/> E6
GLONASS	<input checked="" type="checkbox"/> G1	<input type="checkbox"/> G2		
GPS	<input checked="" type="checkbox"/> L1 C/A	<input type="checkbox"/> L1C	<input type="checkbox"/> L2C	<input type="checkbox"/> L5
SBAS	<input type="checkbox"/> L1	<input type="checkbox"/> L5		



GNSS, GNSS signals and RNSS frequency bands

GNSS	GNSS Signal Designations	RNSS Frequency Band (MHz)
BDS	B1I	1 559 to 1 610
	B1C	1 559 to 1 610
Galileo	E1	1 559 to 1 610
	E5a	1 164 to 1 215
	E5b	1 164 to 1 215
	E6	1 215 to 1 300
GLONASS	G1	1 559 to 1 610
	G2	1 215 to 1 300
GPS	L1 C/A	1 559 to 1 610
	L1C	1 559 to 1 610
	L2C	1 215 to 1 300
	L5	1 164 to 1 215
SBAS	L1	1 559 to 1 610
	L5	1 164 to 1 215

Frequency bands, blocking signal test point centre frequencies and power levels for the 1 559 MHz to 1 610 MHz RNSS band.

Frequency band (MHz)	Test point centre frequency (MHz)	Blocking signal power level (dBm)	Comments
1518 - 1 525	1 524	-65	MSS (space-to-Earth) band
1 525 - 1 549	1 548	-95	MSS (space-to-Earth) band
1 549 - 1 559	1 554	-105	MSS (space-to-Earth) band
1 559 - 1 610	GUE RNSS band under test		
1 610 - 1 626	1 615	-105	MSS (Earth-to-space) band
1 626 - 1 640	1 627	-85	MSS (Earth-to-space) band

Frequency bands, blocking signal test point centre frequencies and power levels for the for the 1164 MHz to 1300 MHz RNSS band.

Frequency band (MHz)	Test point centre frequency (MHz)	Blocking signal power level (dBm)	Comments
960 - 1 164	1 154	-75	AM(R)S, ARNS band
1 164 - 1 215	GUE RNSS band under test		
1 215 - 1 260	GUE RNSS band under test		
1 260 - 1 300	GUE RNSS band under test		
1 300 - 1 350	1 310	-85	Radiolocation, ARNS, RNSS (Earth-to-space) band



(Maximum) signal levels for each GNSS supported.

GNSS constellation	GNSS signal	Signal power level (note)
BDS	B1I	-133 dBm
	B1C (IGSO)	-131 dBm
	B1C (MEO)	-129 dBm
Galileo	E1	-127 dBm
	E5a	-125 dBm
	E5b	-125 dBm
	E6	-125 dBm
GLONASS	G1	-131 dBm
	G2	-137 dBm
GPS	L1 C/A	-128,5 dBm
	L1C	-127 dBm
	L2C	-130 dBm
	L5	-124,9 dBm
SBAS	L1	-131 dBm
	L5	-127,5 dBm

NOTE: The signal power levels represent the total signal power of the satellite per channel, not for example pilot and data channels separately.

UNWANTED EMISSIONS IN THE SPURIOUS DOMAIN TEST (BELOW 1 GHZ):

Following GNSS(s) was (were) selected for the final test as listed below.

EUT CONFIGURE MODE	GNSS	GNSS SIGNAL DESIGNATIONS	RNSS FREQUENCY (MHZ)
-	GLONASS	G1	1605.375 MHz
-	GPS	L1 C/A	1575.42 MHz
-	BDS	B1I	1561.098 MHz
-	GALILEO	E1	1575.42 MHz

UNWANTED EMISSIONS IN THE SPURIOUS DOMAIN TEST (ABOVE 1 GHZ):

Following channel(s) was (were) selected for the final test as listed below.

EUT CONFIGURE MODE	GNSS	GNSS SIGNAL DESIGNATIONS	RNSS FREQUENCY (MHZ)
-	GLONASS	G1	1605.375 MHz
-	GPS	L1 C/A	1575.42 MHz
-	BDS	B1I	1561.098 MHz
-	GALILEO	E1	1575.42 MHz

TEST CONDITION:

Applicable to	Environmental Conditions	Input Power	Tested by
RB	22 °C, 59% RH	DC 3.8V from PCB base support	Yoyo
SE<1G	22 °C, 59% RH	DC 3.8V from PCB base support	Stalker
SE≥1G	22 °C, 59% RH	DC 3.8V from PCB base support	Stalker



2.3 DESCRIPTION OF SUPPORT UNITS

The EUT has been tested as an independent unit together with other necessary accessories or support units. The following support units or accessories were used to form a representative test configuration during the tests.

NO.	PRODUCT	BRAND	MODEL NO.	SERIAL NO.	FCC ID
1	Notebook	DELL	Inspiron 13-7378	GMSJZD2	N/A
2	Wireless Router	TP-LINK	TL-WVR1200G	N/A	N/A
3	SOM Mini SYS test board	N/A	V0.8	N/A	N/A
4	DC Source	Keysight	E3642A	MY56146098	N/A

NO.	SIGNAL CABLE DESCRIPTION OF THE ABOVE SUPPORT UNITS
1	AC Line: Unshielded, Detachable 0.8m; DC Line: Unshielded, Non-detachable 1.8m
2	AC Line: Unshielded, Detachable 1.0m
3	USB Cable: Shielded, Detachable, 0.5m
4	AC Line: Unshielded, Detachable 1.0m

2.4 TEST INSTRUMENTS

Equipment	Manufacturer	Model No.	Serial No.	Next Cal.
Signal Analyzer	Rohde&Schwarz	FSV7	102331	May 21,24
Vector Signal Generator	Rohde&Schwarz	SMBV100A	257579	Sep. 11,24
Signal Generator	Rohde&Schwarz	SMB100A	102383	Mar. 17,24
Signal Generator	Agilent	N5181A	MY50140980	Sep. 18,24
Dual Directional Coupler	TESEQ	C5982	95208	Nov. 08,24
EMI Test Receiver	Rohde&Schwarz	ESU40	100449	Mar. 17,24
Broadcast Test System	Rohde&Schwarz	SFU	101543	May 21,24
Resistive Power Splitter	N/A	1870A	7776	Apr. 04,24

NOTES:

1. The calibration interval of the above test instruments is 12 months; equipment is calibrated by calibration laboratory accredited to ISO/IEC 17025 by a mutually recognized Accreditation.
2. The test was performed in RF Oven room.



2.5 TEST PROCEDURE AND RESULTS

CONFIGURATION OF SYSTEM UNDER TEST

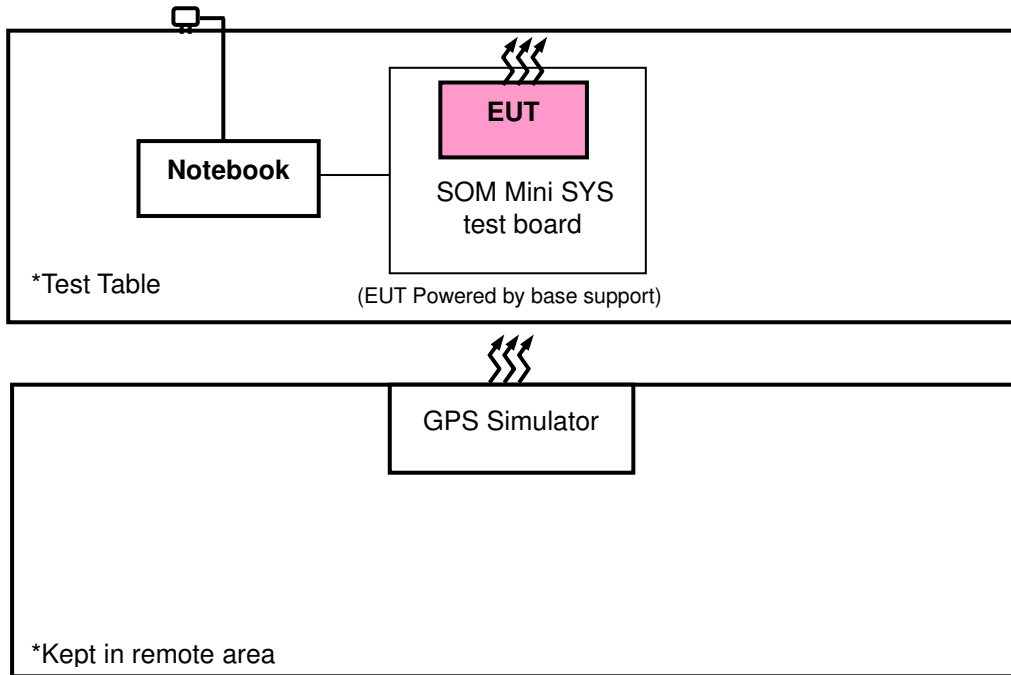

2.6 GENERAL DESCRIPTION OF APPLIED STANDARDS

The EUT is a RF Product. According to the specifications of the manufacturer, it must comply with the requirements of the following standard:

ETSI EN 303 413 V1.2.1 (2021-04)

All test items have been performed and recorded as per the above standard.



3 TEST PROCEDURE AND RESULTS

3.1 RECEIVER BLOCKING

3.1.1 CONFORMANCE SPECIFICATIONS

Condition	Maximum Degradation in C/N ₀
Under all test conditions	$\Delta C/N_0 \leq 1$ dB

3.1.2 TEST PROCEDURES

Refer to clause 5.4 of ETSI EN 303 413 V1.2.1 (2021-04)

Measurement Method	
<input checked="" type="checkbox"/> Conducted measurement	<input type="checkbox"/> Radiated measurement

3.1.3 DEVIATION FROM TEST STANDARD

No deviation.

3.1.4 TEST SETUP

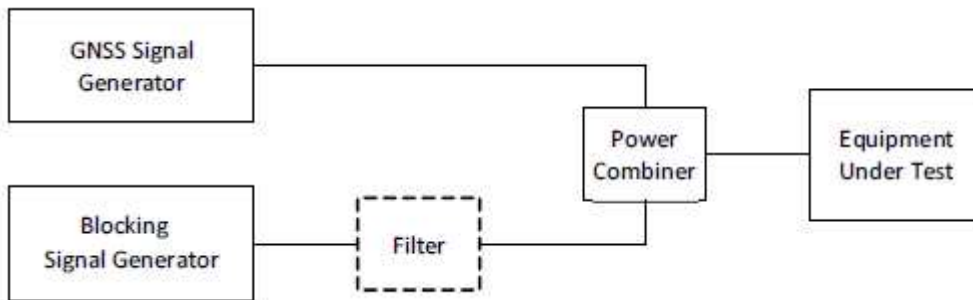

The measurements for Receiver blocking were performed at both normal environmental conditions. Controlling software has been activated to set the EUT on specific GNSS and power level.



3.1.5 TEST RESULTS

Test results for the 1 559 MHz to 1 610 MHz RNSS band.

Frequency band (MHz)	Test point centre frequency (MHz)	Blocking signal power	Measured C/N ₀ (dB-Hz)			
	From table 4-2		From table 4-2	No blocking signal	With blocking signal	Decrease of C/N ₀
1 518 - 1 525	1524	-65	32	32	0	<input checked="" type="checkbox"/> Pass <input type="checkbox"/> Fail <input type="checkbox"/> N/A BDS
			27	27	0	<input checked="" type="checkbox"/> Pass <input type="checkbox"/> Fail <input type="checkbox"/> N/A Galileo
			33	33	0	<input checked="" type="checkbox"/> Pass <input type="checkbox"/> Fail <input type="checkbox"/> N/A GLONASS
			33	33	0	<input checked="" type="checkbox"/> Pass <input type="checkbox"/> Fail <input type="checkbox"/> N/A GPS
						<input type="checkbox"/> Pass <input type="checkbox"/> Fail <input checked="" type="checkbox"/> N/A SBAS
1 525 - 1 549	1548	-95	32	32	0	<input checked="" type="checkbox"/> Pass <input type="checkbox"/> Fail <input type="checkbox"/> N/A BDS
			27	27	0	<input checked="" type="checkbox"/> Pass <input type="checkbox"/> Fail <input type="checkbox"/> N/A Galileo
			33	33	0	<input checked="" type="checkbox"/> Pass <input type="checkbox"/> Fail <input type="checkbox"/> N/A GLONASS
			33	33	0	<input checked="" type="checkbox"/> Pass <input type="checkbox"/> Fail <input type="checkbox"/> N/A GPS
						<input type="checkbox"/> Pass <input type="checkbox"/> Fail <input checked="" type="checkbox"/> N/A SBAS
1 549 - 1 559	1554	-105	32	32	0	<input checked="" type="checkbox"/> Pass <input type="checkbox"/> Fail <input type="checkbox"/> N/A BDS
			27	27	0	<input checked="" type="checkbox"/> Pass <input type="checkbox"/> Fail <input type="checkbox"/> N/A Galileo
			33	33	0	<input checked="" type="checkbox"/> Pass <input type="checkbox"/> Fail <input type="checkbox"/> N/A GLONASS
			33	33	0	<input checked="" type="checkbox"/> Pass <input type="checkbox"/> Fail <input type="checkbox"/> N/A GPS
						<input type="checkbox"/> Pass <input type="checkbox"/> Fail <input checked="" type="checkbox"/> N/A SBAS
1 610 - 1 626	1615	-105	32	32	0	<input checked="" type="checkbox"/> Pass <input type="checkbox"/> Fail <input type="checkbox"/> N/A BDS
			27	27	0	<input checked="" type="checkbox"/> Pass <input type="checkbox"/> Fail <input type="checkbox"/> N/A Galileo
			33	33	0	<input checked="" type="checkbox"/> Pass <input type="checkbox"/> Fail <input type="checkbox"/> N/A GLONASS
			33	33	0	<input checked="" type="checkbox"/> Pass <input type="checkbox"/> Fail <input type="checkbox"/> N/A GPS
						<input type="checkbox"/> Pass <input type="checkbox"/> Fail <input checked="" type="checkbox"/> N/A SBAS
1 626 - 1 640	1627	-85	32	32	0	<input checked="" type="checkbox"/> Pass <input type="checkbox"/> Fail <input type="checkbox"/> N/A BDS
			27	27	0	<input checked="" type="checkbox"/> Pass <input type="checkbox"/> Fail <input type="checkbox"/> N/A Galileo
			33	33	0	<input checked="" type="checkbox"/> Pass <input type="checkbox"/> Fail <input type="checkbox"/> N/A GLONASS
			33	33	0	<input checked="" type="checkbox"/> Pass <input type="checkbox"/> Fail <input type="checkbox"/> N/A GPS
						<input type="checkbox"/> Pass <input type="checkbox"/> Fail <input checked="" type="checkbox"/> N/A SBAS



Test results for the 1 164 MHz to 1 300 MHz RNSS band

Frequency band (MHz)	Test point centre frequency (MHz)	Blocking signal power	Measured C/N ₀ (dB-Hz)			
	From table 4-3		From table 4-3	No blocking signal	With blocking signal	Decrease of C/N ₀
960 - 1 164	1154	-75	--	--	--	BDS <input type="checkbox"/> Pass <input type="checkbox"/> Fail <input checked="" type="checkbox"/> N/A
			--	--	--	Galileo <input type="checkbox"/> Pass <input type="checkbox"/> Fail <input checked="" type="checkbox"/> N/A
			--	--	--	GLONASS <input type="checkbox"/> Pass <input type="checkbox"/> Fail <input checked="" type="checkbox"/> N/A
			--	--	--	GPS <input type="checkbox"/> Pass <input type="checkbox"/> Fail <input checked="" type="checkbox"/> N/A
			--	--	--	SBAS <input type="checkbox"/> Pass <input type="checkbox"/> Fail <input checked="" type="checkbox"/> N/A
1 300 - 1 350	1310	-85	--	--	--	BDS <input type="checkbox"/> Pass <input type="checkbox"/> Fail <input checked="" type="checkbox"/> N/A
			--	--	--	Galileo <input type="checkbox"/> Pass <input type="checkbox"/> Fail <input checked="" type="checkbox"/> N/A
			--	--	--	GLONASS <input type="checkbox"/> Pass <input type="checkbox"/> Fail <input checked="" type="checkbox"/> N/A
			--	--	--	GPS <input type="checkbox"/> Pass <input type="checkbox"/> Fail <input checked="" type="checkbox"/> N/A
			--	--	--	SBAS <input type="checkbox"/> Pass <input type="checkbox"/> Fail <input checked="" type="checkbox"/> N/A



3.2 RECEIVER SPURIOUS EMISSIONS

3.2.1 LIMIT OF RECEIVER SPURIOUS RADIATION

Frequency Range	Maximum Power Limit	Bandwidth
30 MHz ~ 1 GHz	-57dBm	100 kHz
1 GHz ~ 8.3 GHz	-47dBm	1 MHz

Note: These limits are e.r.p. for emissions up to 1 GHz and as e.i.r.p. for emissions above 1 GHz.

3.2.2 TEST PROCEDURE

Refer to clause 5.5 of ETSI EN 303 413 V1.2.1 (2021-04)

Measurement Method	
<input type="checkbox"/> Conducted measurement	<input checked="" type="checkbox"/> Radiated measurement
<p><u>For Conducted measurement:</u></p> <p>The level of unwanted emissions shall be measured as their power in a specified load (conducted spurious emissions) and their effective radiated power when radiated by the cabinet or structure of the equipment with the antenna connector(s) terminated by a specified load (cabinet radiation).</p>	
<p><u>Conducted measurement (For equipment with multiple transmit chains):</u></p> <p><input type="checkbox"/> Option 1: The results for each of the transmit chains for the corresponding 1MHz segments shall be added and compared with the limits.</p> <p><input type="checkbox"/> Option 2: The results for each of the transmit chains shall be individually compared with the limits after these limits have been reduced by 10 x log (N) (number of active transmit chains)</p>	

3.2.3 DEVIATION FROM TEST STANDARD

No deviation.

3.2.4 TEST SETUP

1. For the actual test configuration, please refer to the related Item in this test report (Photographs of the Test Configuration).
2. Testing was performed when the equipment was in a receive-only mode.
3. The test setup has been constructed as the normal use condition. Controlling software has been activated to set the EUT on specific status.



3.2.5 TEST RESULTS

RX Below 1GHz Worst Data:

Frequency Range	30 MHz ~ 1 GHz	Operating GNSS	GLONASS 1605.375MHz
------------------------	----------------	-----------------------	---------------------

SPURIOUS EMISSION LEVEL				
Frequency (MHz)	Antenna Polarization	Level (dBm)	Limit (dBm)	Margin (dB)
177.60	V	-81.55	-57.00	-24.55
187.43	V	-81.11	-57.00	-24.11
210.87	H	-82.46	-57.00	-25.46
214.82	V	-79.78	-57.00	-22.78
219.80	H	-80.33	-57.00	-23.33
238.94	H	-76.33	-57.00	-19.33
243.30	V	-78.23	-57.00	-21.23
258.21	H	-79.79	-57.00	-22.79
368.66	V	-78.27	-57.00	-21.27
268.17	H	-81.45	-57.00	-24.45
475.75	H	-77.64	-57.00	-20.64
475.78	V	-75.12	-57.00	-18.12

Frequency Range	30 MHz ~ 1 GHz	Operating GNSS	GPS 1575.42MHz
------------------------	----------------	-----------------------	----------------

SPURIOUS EMISSION LEVEL				
Frequency (MHz)	Antenna Polarization	Level (dBm)	Limit (dBm)	Margin (dB)
33.14	H	-79.36	-57.00	-22.36
137.70	H	-78.19	-57.00	-21.19
156.13	V	-80.97	-57.00	-23.97
225.81	H	-71.43	-57.00	-14.43
233.57	V	-78.85	-57.00	-21.85
240.78	H	-69.70	-57.00	-12.70
321.61	V	-76.64	-57.00	-19.64
348.58	H	-70.93	-57.00	-13.93
352.17	V	-74.36	-57.00	-17.36
407.33	V	-76.35	-57.00	-19.35
475.78	H	-66.18	-57.00	-9.18
475.78	V	-71.56	-57.00	-14.56



Frequency Range	30 MHz ~ 1 GHz	Operating GNSS	BDS 1561.098MHz
------------------------	----------------	-----------------------	-----------------

SPURIOUS EMISSION LEVEL				
Frequency (MHz)	Antenna Polarization	Level (dBm)	Limit (dBm)	Margin (dB)
213.59	H	-76.05	-57.00	-19.05
232.37	V	-77.44	-57.00	-20.44
233.70	H	-75.52	-57.00	-18.52
237.06	H	-72.54	-57.00	-15.54
247.86	H	-76.52	-57.00	-19.52
267.23	H	-75.70	-57.00	-18.70
329.63	V	-77.62	-57.00	-20.62
348.32	V	-74.53	-57.00	-17.53
396.05	V	-77.26	-57.00	-20.26
475.78	V	-76.38	-57.00	-19.38
475.78	H	-67.65	-57.00	-10.65
508.66	V	-81.44	-57.00	-24.44

Frequency Range	30 MHz ~ 1 GHz	Operating GNSS	GALILEO 1575.42MHz
------------------------	----------------	-----------------------	--------------------

SPURIOUS EMISSION LEVEL				
Frequency (MHz)	Antenna Polarization	Level (dBm)	Limit (dBm)	Margin (dB)
31.68	H	-78.22	-57.00	-21.22
107.63	H	-77.85	-57.00	-20.85
131.98	V	-78.71	-57.00	-21.71
223.00	H	-72.65	-57.00	-15.65
232.37	V	-77.44	-57.00	-20.44
254.39	H	-75.70	-57.00	-18.70
324.43	H	-72.73	-57.00	-15.73
329.63	V	-77.62	-57.00	-20.62
348.32	V	-74.53	-57.00	-17.53
359.15	V	-77.28	-57.00	-20.28
373.15	H	-79.75	-57.00	-22.75
475.78	V	-72.75	-57.00	-15.75



RX Above 1GHz Data

Frequency Range	1 GHz ~ 8.3 GHz	Operating GNSS	GLONASS 1605.375MHz
------------------------	-----------------	-----------------------	---------------------

SPURIOUS EMISSION LEVEL				
Frequency (MHz)	Antenna Polarization	Level (dBm)	Limit (dBm)	Margin (dB)
3210.75	H	-59.47	-47.00	-12.47
3210.75	V	-59.21	-47.00	-12.21
4816.72	H	-55.36	-47.00	-8.36
4816.72	V	-55.36	-47.00	-8.36

Frequency Range	1 GHz ~ 8.3 GHz	Operating GNSS	GPS 1575.42MHz
------------------------	-----------------	-----------------------	----------------

SPURIOUS EMISSION LEVEL				
Frequency (MHz)	Antenna Polarization	Level (dBm)	Limit (dBm)	Margin (dB)
3150.84	H	-58.24	-47.00	-11.24
3150.84	V	-58.24	-47.00	-11.24
4726.26	H	-55.67	-47.00	-8.67
4726.26	V	-55.67	-47.00	-8.67

Frequency Range	1 GHz ~ 8.3 GHz	Operating GNSS	BDS 1561.098MHz
------------------------	-----------------	-----------------------	-----------------

SPURIOUS EMISSION LEVEL				
Frequency (MHz)	Antenna Polarization	Level (dBm)	Limit (dBm)	Margin (dB)
3122.20	H	-59.09	-47.00	-12.09
3122.20	V	-58.38	-47.00	-11.38
4683.29	H	-60.01	-47.00	-13.10
4683.29	V	-56.00	-47.00	-9.00

Frequency Range	1 GHz ~ 8.3 GHz	Operating GNSS	GALILEO 1575.42MHz
------------------------	-----------------	-----------------------	--------------------

SPURIOUS EMISSION LEVEL				
Frequency (MHz)	Antenna Polarization	Level (dBm)	Limit (dBm)	Margin (dB)
3150.84	H	-59.82	-47.00	-12.82
3150.84	V	-59.43	-47.00	-12.43
4726.26	H	-58.07	-47.00	-11.07
4726.26	V	-58.44	-47.00	-11.44



4 PHOTOGRAPHS OF THE TEST CONFIGURATION

RECEIVER BLOCKING



RADIATED EMISSION (BELOW 1GHz)

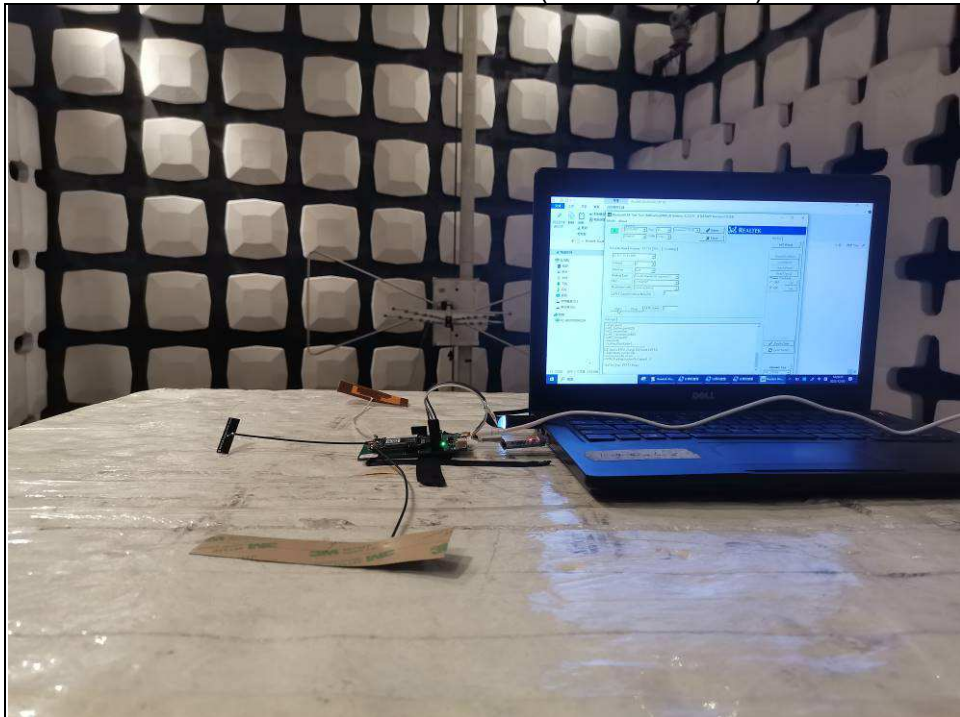



RADIATED EMISSION (ABOVE 1GHz)

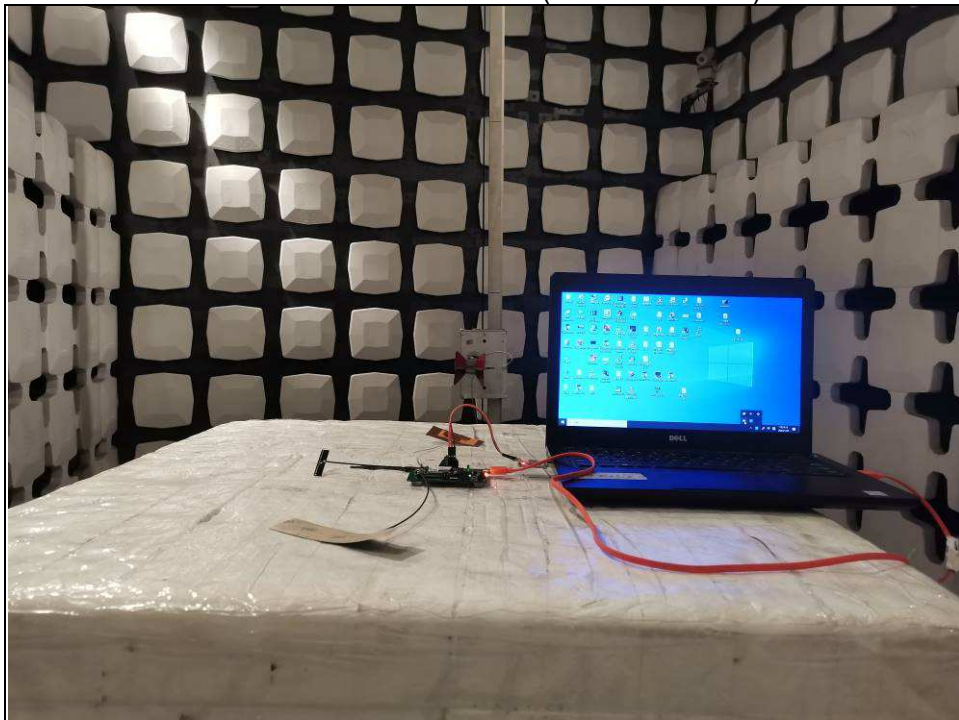



BUREAU
VERITAS

Test Report No.: RE2312WDG0147-6

5 APPENDIX A – MODIFICATIONS RECORDERS FOR ENGINEERING CHANGES TO THE EUT BY THE LAB

No modifications were made to the EUT by the lab during the test.

--- END ---