



Specification of Lithium-ion Cylindrical Rechargeable Battery

锂离子圆柱电池规格书

Product Type 产品类型:	Lithium-ion Cylindrical Rechargeable Battery 锂离子圆柱电池
Battery Model 电池型号:	18650-3P(电芯品牌LG18650)
Product Description 产品描述:	3P with PCM 3P含保护板
Battery Capacity 电池容量:	9750mAh

Customer Approval 客户确认	Company Name: 公司名称:	
	Material number 物料号	110-00009
	Signature 签名	
	Date 日期	
	Company Stamp : 公司盖章:	

拟制	审核	批准
周世焙	邝榆文	骆浩强

地址: 广东省佛山市南海区丹灶镇下滘村寮口开发大道11号  
邮编: 528216  
业务部:(+86)757-81289786,81039626  
传真:(+86)757-81289787  
E-Mail: Info@zn-battery.com  
网址: http://www.zhaoneng-battery.com

Add: No. 11, Doukou Development Zone Avenue, Xiajiao village, Danzao Town, Nanhai District, Foshan City, Guangdong Province, China  
Zip code: 528216  
Business:(+86)757-81289786,81039626  
Fax:(+86)757-81289787  
E-Mail: Info@zn-battery.com  
Website: http://www.zhaoneng-battery.com.



## Contents 目录

1、Scope/范围	4
2、Product/产品	4
3、Specification /产品规格	4、5
4、Battery outward appearance and Dimension /成品外形和物理尺寸	6
4、Battery Basis BOM List /成品基本BOM清单	6
4、Outward appearance and Dimension /外形和物理尺寸	7
5、Packing drawing 包装图	7
5、PCM parameters 保护板参数	8
5、PCM BOM List 保护板BOM清单	8
5、PCM Schematic diagram 保护板原理图	8
5、Circuit PCM diagram 保护板布线图	9
5、PCM Pad description 保护板位号描述	9
6、Visual Inspection/外观	10
7、Electrical characteristics/电气特性	10
7、Mechanical characteristics/机械特性	11
8、Standard environmental test condition/测试条件	12
9、Charging/充电	12
10、warranty/品质保证	12
11、Liability/产品责任	12
12、Identification/成品电池块（组）标识	12
13、Notice for Designing Battery Pack /电池注意事项	13
14、Warnings 警告语	14
15、Attention 注意项	15
16、1Reminding 提醒项	15

**1. Scope/范围**

This document describes the product specification and using condition of the Lithium-ion Cylindrical rechargeable cell supplied by GUANGDONG ZHAONENG Technology Co., Ltd..

本文件描述了广东兆能科技有限公司生产的可充电圆柱锂离子电池的产品性能及使用条件。

**2. Product/产品**

2.1 Name : Lithium-ion polymer rechargeable cell

名称: 可充电聚合物锂离子电池

2.2 Battery Model: 18650-3P(电芯品牌LG18650)

电池型号: 18650-3P(电芯品牌LG18650)

**3. Specification /产品规格**

NO. 序号	Items 项目	Specifications 规格	Remark 备注
1	Nominal voltage 标称电压	3.7 V	
2	2.1 Nominal capacity 典型容量	9750 mAh	According to the standard charging after full charge, constant current discharge 0.2C to 3V. 按标准充电方式充满电后, 以 0.2C 恒流放电到3V
	2.2 Minimum Capacity 最小容量	9600 mAh	
3	Initial Impedance 初始内阻	≤ 150 mΩ	AC Impedance 交流内阻 1KHz
4	Charge Cutoff Voltage 充电截止电压	4.2 V	
5	Discharge Cut-off Voltage 放电截止电压	3.00 V	
6	Shipment voltage 出货电压	3.5-4.0 V	
7	Battery weight 电池重量	≈ 160.0 g	
8	8.1 Standard Charge 标准充电	0.2C CC (constant current) charge to 4.2V, then CV (constant voltage 4.2V) charge till charge current decline to 0.02C 0.2C恒流充电至4.2V, 再恒压充电至电流为0.02C	
	8.2 Standard Discharge 标准放电	0.2C CC (constant current) discharge to 3V 0.2C恒流放电至3V	
	8.3 Standard testing condition 标准测试环境	Temperature 温度: 25±2° C ; Humidity 湿度: ≤85%RH Atmospheric Pressure 大气压: 86-106kPa	
9	Max discharge current 最大放电电流	5000mA	
10	Operating Temperature 工作温度	Charge: 5~45°C	
		Discharge: -20~60°C	
11	Max charge current 最大充电电流	5~15°C: 0.2C CCCV to 4.2V	Charge at very low temperature such as below 10°C, will be get a lower capacity and reduce cycle life of the battery 低温充电效率会下降, 会影响电池使用寿命
		15~45°C: 5000mA CCCV to 4.2V	
12	Max Discharge current 最大放电电流	(-20°C) ~ (60°C) 0.2C DC to 3.0V	
		(0°C) ~ (60°C) : 5000mA DC to 3.0V	



NO. 序号	Items 项目	Specifications 规格	Remark 备注
13	Storage temperature 储存温度	≤1 months: -20°C ~45°C	a) The capacity for storage shall be 50~75% SOC 存储电量为50~75%; b) The battery should cycle once in Six Months. Recommended storageTemperature is 25°C of SOC 50~75%; 电池储存过程需6个月内充放一次电, 推荐电池在25°C, 50~75%电量的状态下储存。
		≤3 months: -20°C ~35°C	
		≤1 year: -20°C ~25°C	
14	Storage Humidity 储存湿度	≤75% RH	



4.1 Outward appearance and Dimension /外型和物理尺寸

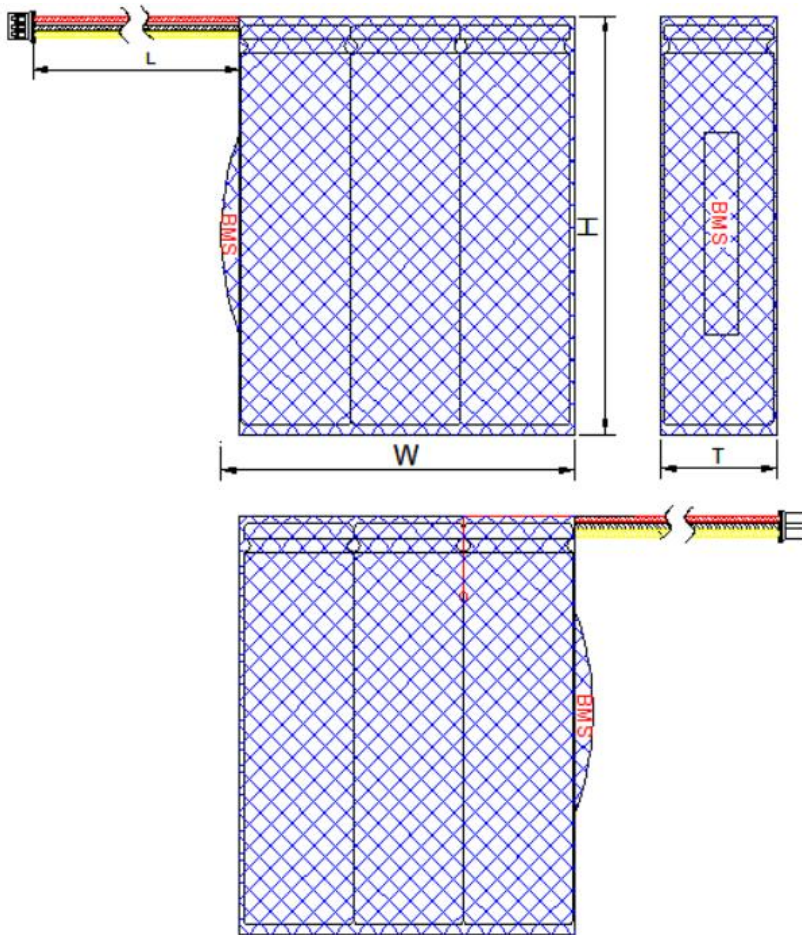

单位: mm

项目	尺寸
电池直径T	Max: 20.5
电池宽W	Max: 59.0
电池高度H	Max: 69.0
线长L	100±10

4.2 Basis BOM List/基本BOM表

Item 序号	Reference 名称	Material name 规格	Model/Specification 描述	Quantity 用量	Remark 备注
1	Cell 电芯	INR18650 MJ1	3.7V 3500 mAh	3	
2	PCM	ZN-PCM	S8261DAB*1+XR3330M*1+S8261DAI*1+XR3330M*1+10KNTC+PTC (5A)	1	
3	Red wire 红线	UL1571 AWG22#	Red	1	
4	Black wire 黑线	UL1571 AWG22#	Black	1	
5	Yellow wire 黄线	UL1571 AWG22#	Yellow	1	
6	Connector 端子	PH-3P	正面黄黑红 (Yellow-Black-Red)	1	



### 4.3 Outward appearance and Dimension /外型 and 物理尺寸

单位: mm

项目	尺寸
电池直径 $\Phi$	Max: 18.45
电池高度H	Max: 65.25

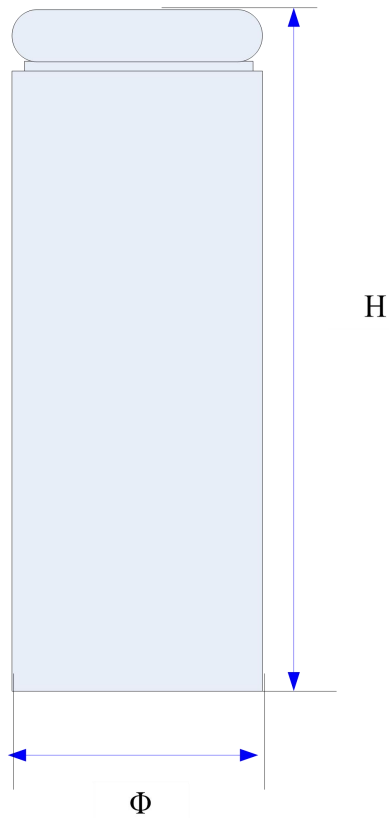

### 5.Packing drawing 包装图

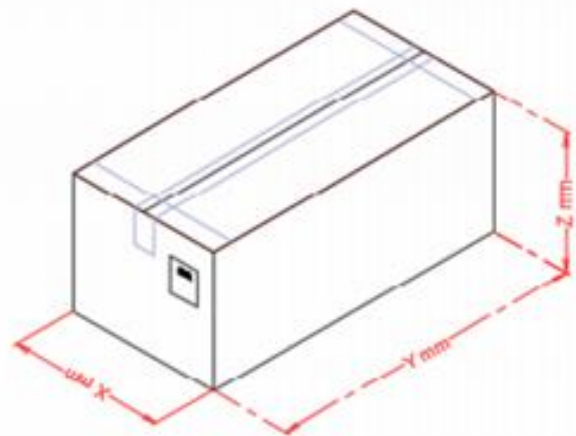
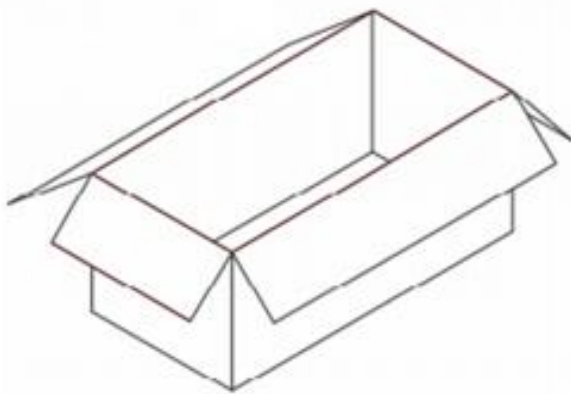

NO.序号	Items项目	Description描述
1	Packing style 包装方式	Carton 外箱
2	Carton Sealing method 封箱方式	Transparent adhesive tape 透明封箱胶带



5.1 PCM/保护板参数

Symbol (符号)	Name (名称)	MIN (最小值)	Typical. (典型值)	Max (最大值)	Unit (单位)
VDET1	Over-Charge detect voltage (过充电保护电压)	4.260	4.28	4.300	V
VDET2	Over-discharge detect voltage (过放电保护电压)	2.950	3.00	3.050	V
IEC	Excess Current threshold (最大过流值)	10.0	---	20.0	A
IDD	Supply current (自耗电流)	---	3.5	7	μA
RD	Internal resistance in normal operation (导通内阻)	---	---	120	mΩ

二级保护参数

Symbol (符号)	Name (名称)	MIN (最小值)	Typical. (典型值)	Max (最大值)	Unit (单位)
VDET1	Over-Charge detect voltage (过充电保护电压)	4.260	4.28	4.300	V
VDET2	Over-discharge detect voltage (过放电保护电压)	2.250	2.30	2.350	V
IEC	Excess Current threshold (最大过流值)	8.0	---	17.0	A

5.2 保护板BOM 清单

序号	物料名称	位号	物料规格	封装	用量
1	SMD CAP	C1-2	CAP-0.1UFX7R16VZ0402,0.1u F	0402	2
2	SMD 电阻	R1-2	RES-1/10W330R5%,330Ω,5%	0603	2
3	SMD 电阻	R3-4	RES-1/10W470R5%,470Ω,5%	0603	2
4	蝌蚪 NTC	NTC1	NTC-10KRF3435FTF	K	1
5	PTC	P1	FUSE-1,TLC-NSML500	1206	1
6	IC	U1	LBP-1S,S-8261DAB	SOT23-6	1
7	IC	U2	LBP-1S,S-8261DAI	SOT23-6	1
8	MOSFET	Q1-2	XR3330M	DFN3333-8L	2
9	镀镍钢片	B+ B-	CON,,5*3*0.3	PAD	2
10	PCB		35*8 *0.6 mm 1 OZ 绿油白字		1

5.3 Schematic diagram(原理图)

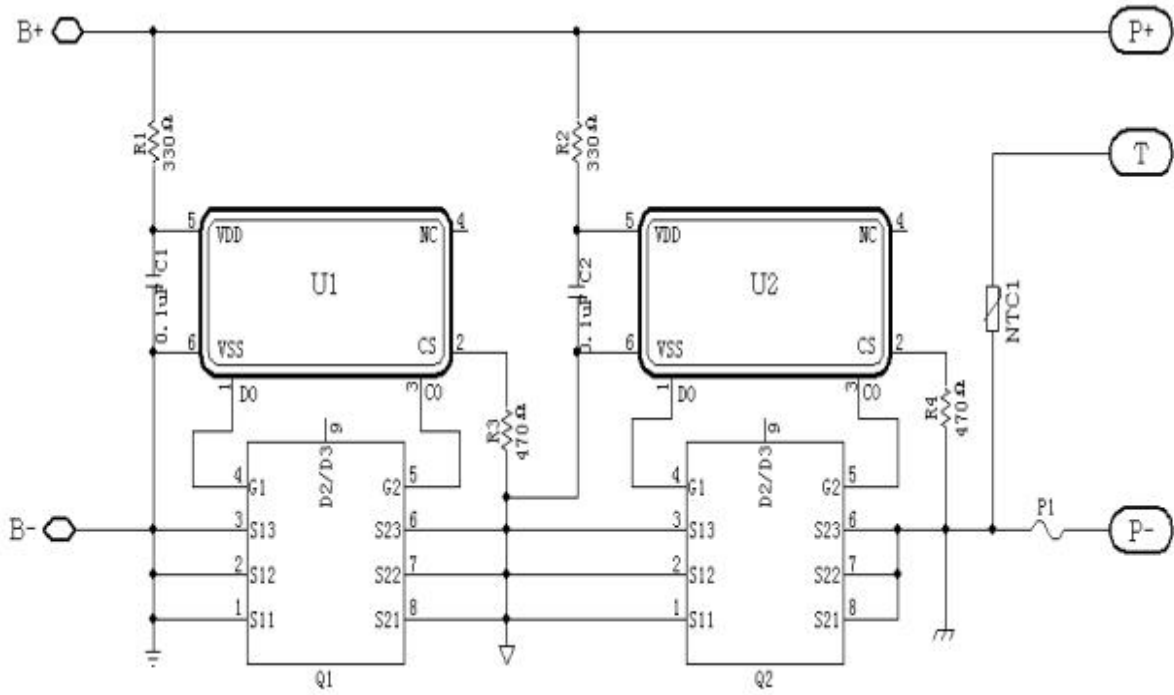

5.4. Circuit PCB diagram(布线图)

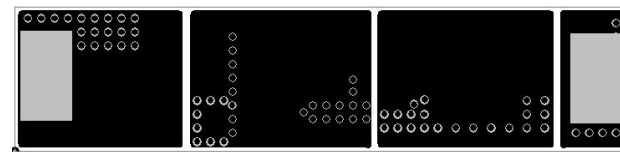
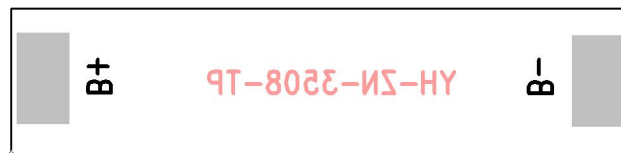
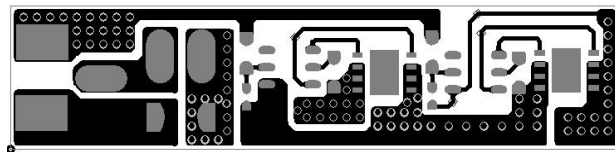
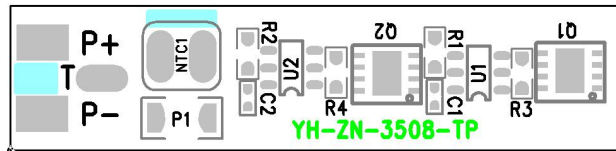



**6. Visual Inspection/外观**

There shall be no such defect as scratch,flaw,crack,and leakage,which may adversely affect commercial value of the cell.  
不允许有任何影响电芯性能的外观缺陷，如裂纹、裂缝、泄漏等。

**7. Cell Specification/电芯规格**

7.1 Electrical characteristics

电气特性

Items	Test Method and Condition				Criteria
7.1.1 Initial capacity 初始容量	The capacity means the discharge capacity of the cell that was discharged to 3.0V with discharge current of 0.2C within one hour after the full charge. 容量,即指在电池满充电后1小时内用0.2C电流放电,放电至3.0V截止的放电容量				$\geq$ 9600 mAh
7.1.2 Cycle life 循环寿命	Cycle life is the capacity of the cell that was repeated 300 cycles with full charge and then discharging to 3.0V with discharge current of 0.2C . 测量电池满充电后以0.2C放至3.0V，充放电循环300次后的放电容量。				$\geq$ 60% Initial capacity
7.1.3 Initial impedance 内阻	Cell resistance was measured at AC 1KHz after 50% charge and the test temperature was 25°C . 半充电状态，在1kHz下测量电池内部阻抗。测试温度为室温（25°C）				$\leq$ 150 mΩ
7.1.4 Temperature Capacity Test 温度性能	The discharge capacity of contrast, under the conditions of different temperature in 25 °C under the condition of normal temperature after full charge of the battery, as shown in the table below normal temperature and high temperature to the capacity of 0.2 C to 3.0V, low temperature is 0.2C to 3.0 V discharge capacity.the time between charging and discharging must beyond 3 hours. 不同温度条件下的放电容量对比，即在25°C常温条件下电池满充电后，在下表所示常温和高温度下以0.2C放至3.0V的容量，低温为0.2C放电至3.0V的容量。如果充电和放电温度不是同一温度时，温度变化的间隔时间要求是3小时。				
	Charge temperature 充电温度		Discharge temperature		
	25°C		-10°C $\geq 60\%$	0°C $\geq 80\%$	25°C 100%
7.1.5 Self-discharge 自放电	After the full charging, storage the cells in a temperature of 25°C for 28 days, then measure the capacity with discharge current of 0.2C till 3.0V. 满充电后在25°C下储存28天,检测0.2C放电至3.0V的容量。				Capacity $\geq$ 90% Initial capacity



## 7.2 Mechanical characteristics

## 机械特性

Items	Test Method and Condition	Criteria
7.2.1 Vibration Test 振动	Fixed the fully charged cell to vibration table and subjected to vibration cycling that the frequency is to be varied at the rate of 1Hz per minute between 10Hz and 55Hz, the excursion of the vibration is 0.8mm. The cell shall be vibrated for 90~100 minutes per axis of XYZ axes.  电池按照振幅为0.8mm的谐振形式进行振动。振动频率在10和55Hz间以1Hz / min的速率变化，往复振动90~100min。电池应该在互相垂直的三个面进行测试。	No explosion No fire, No leakage. 电池不爆炸，不起火，不漏液
7.2.2 Drop Test 跌落	The cell was dropped freely from the height of 1000mm to the concrete floor, and each surface was dropped once  将电芯从高度1000mm的位置自由跌落到水泥地面上，每个面各跌落1次。	No explosion, No fire 电池不爆炸，不起火

## 7.3 Safety 安全测试

Items	Test Method and Condition	Criteria
7.3.1 Crush Test 挤压	The pressure on the surface of the fully charged cell do not stop being raised until 17.2 Mpa when the cell is crushed by two flat surfaces.(Max13kN)  满充电电池被两平板挤压。挤压的最大压强为17.2Mpa,最大作用力为13kN。当达到最大值即停止。	No explosion, No fire. 电池不爆炸，不起火
7.3.2 Heating 热冲击	After full charging at 0.1C, put the battery in the baking oven and start , the temperature of the oven is to be raised at a rate of 5°C per minute to a temperature of 130±2°C, remain for 10minutes at that temperature  用0.2C将电池满充电后，放置于热箱中，温度以5°C / min 的速率升至 130°C ±2°C并保温 10min。	
7.3.3 Short-Circuit Test 短路	After full charge, the positive and negative polarities are connected together by a copper wire whose resistance is less than or equal to 80±20mΩ.  满充电电池用电阻不大于80±20mΩ的铜导线连接其正负极至电池体温度接近室温。	No explosion, No fire . 电池不爆炸，不起火
7.3.4 Over-charge Test 过充	The cell is overcharged to 4.6V with a current of 3C and holded for 8 hours.  电池在3C恒流恒压下过充至4.6V，并保持7小时	



## 8. Standard environmental test condition/测试条件

Unless otherwise specified, all tests stated in this Product Specification are conducted at below condition.

Temperature: 25±2℃

Relative humidity : 65±20%

除特别说明外，本规格书中所有测试均在以下环境中进行。

温度：25±2℃ 相对湿度：65±20%

## 9. Charging/充电

Charging current and charging voltage should be less than specified in the Product Specification.

The charger shall be designed to comply with Product Specification.

It is dangerous that charging with higher current or voltage than Product Specification may cause damage to the cell electrical,mechanical safety performance.

充电电流和充电电压不得超出本规格书中所规定的最大值。

充电器的设计应满足本规格书的要求。

使用超出本规格书要求的电流和电压范围可能引起电芯充放电性能、机械性能和安全性能的问题。

## 10. warranty/品质保证

Period of warranty: 12 months after sales;

产品保质期: 自交货期开始算起后的12个月;

Range of warranty: There is low voltage, expansion or leakage with the correct use of the cell in the period of warranty.

保质范围: 正常使用或存放条件下电池有气鼓、无电压、漏液不良现象。

不当使用或存放造成电池不良不在保质范围内。

## 11. Liability/产品责任

Please use the Lithium-ion Polymer rechargeable cells supplied by GUANGDONG ZHAONENG Technology Co., Ltd. under the product specification .It may cause fire or expansion if the cells are used incorrect .We will not guarantee the safety unless the cells are used under the product specification.

请客户务必按照所提供的规格说明书和所附的注意事项来使用广东兆能科技有限公司生产的电池。不正确地使用电池，可能会导致电池性能异常、发热、着火或破裂现象。对于客户在超出规格说明书以外的情况下使用电池，广东兆能科技有限公司不保证其使用性能和安全性能。

## 12. Identification/成品电池块（组）上标识

Warnings would better be marked on the surface of the battery which is tied up by certain cells:

\*Using the charger designated by the manufacturer.

\*Don't throw the battery in fire or heat it .

\*Don't short-circuit .

\*Don't unpack the battery or change its structure.

对用于制作电池块（组），请在电池块（组）上标记以下警告：

\*使用（制造厂商）指定的充电器。

\*禁止将电池投入火中或是对电池加热。

\*禁止将电池正负极短路。

\*禁止拆开，改变电池（组）结构。



### 13. Notice for Designing Battery Pack / 电池块设计注意事项

#### 13.1 Battery Pack design

电池块设计

13.1.1 Battery shell should be with enough mechanical strength, to protect the inner cell from mechanical shock;

电池外壳应有足够的机械强度以保证其内部电芯免受机械撞击；

13.1.2 No cell movement in the battery pack should be allowed;

电芯不得在壳内活动；

13.1.3 No Sharp edge or bulge components should be inside the pack containing the battery;

外壳内安装电芯的部位不应有锋利的边角或凸起；

13.2 Avoid some components to contact the edge of packing foil of batteries ;

避免导电元件与电芯包装铝箔的边缘接触；

#### 13.3 Tab connection

电芯的连接

13.3.1 Ultrasonic welding or spot welding is recommended to connect battery with PCM or other parts;

建议使用超声波焊接或点焊技术来连接电芯与保护电路模块或其它部分；

13.3.2 The tab is not very firm. Don't bend the tab. especially the positive pole. It will rupture easily;

电池极耳的机械强度并非十分坚固,弯折容易断裂,尤其是正极耳.禁止多次弯折极耳；

13.3.3 If apply manual solder method to connect tab with PCM, below notice is very important to ensure battery performance:

如使用手工锡焊，须注意以下事项，以保证电芯的功能：

1). The solder iron should be temperature controlled and ESD safe;

烙铁的温度可控且防静电；

2). The soldering iron temperature should be 360-420°C;

烙铁温度应该在360-420°C；

3). Soldering time should not be longer than 3s ;

锡焊时间不能超过 3 秒；

4). Soldering times should not exceed 3 times ,secondary welding should be done after the poles are cooling;

锡焊次数不能超过 3 次，必须在极耳冷却后再进行二次焊接；

5). Directly heat cell body is strictly prohibited;

禁止直接加热电芯，高于 100°C会导致电芯损坏；

6). Don't let the electric iron contact the surface of the cell.

禁止电烙铁头接触电池表面。



Please use the battery according to the provisions as below ,Incorrect using of the battery may cause fire or expansion,and destroy its performance.

请仔细阅读并遵照以下条款安装使用电池，不正确的使用可能会导致电池气鼓、着火等，降低了电池的性能或破坏电池。

#### 14.Warnings 警告

14.1 Don't throw the cell in fire or heat it or store it in high temperature place ;

请勿将电池放入火中，或对电池加热，请勿在高温下储存电池；

14.2 Don't operate or use the cell under high temperature or next to the heating material. Don't throw the cell in fire or heat it;

禁止在高温环境下或热源旁操作或者使用电池,禁止将电池加热或者投入火中；

14.3. Don't fix the positive and negative of the cell reversely to the electrical equipment ;

安装电池时请勿将正负极反接；

14.4 Don't connect the positive and negative polarities by metallic conductor such as a metallic wire;

请勿将电池正负极用金属物体（如导线）直接连接等方式造成电池短路；

14.5 Don't impact or scrape the surface of the cell by spiculate parts;

禁止用尖锐部件碰撞或刮擦电池表面；

14.6 Don't stab it with a needle,beating,treading,fold or other way;

请勿用针刺、用锤敲打、用力踩踏、弯折或其它方式对电池进行撞击；

14.7 Don't drop or fling the cell randomly;

禁止坠落、抛掷电池；

14.8 Keep the cell sealed!(Don't open or deform folding edge,Don't bend or fold sealing edge,etc);

请勿破坏电池密封(包括打开折边、弯折封边等)；

14.9 Don't unpack the battery or change its structure!;

请勿乱拆电池，请勿随意改变电池结构；

14.10 Don't throw the cell in water,please keep it from humidity.

请勿将电池放入水中，储存时注意电池不要受潮。



### 15.Attention注意

- 15.1 Please use the qualified equipment for charging and recharging the cell;  
充放电时请勿用不合格设备，并遵循正确的使用说明；
- 15.2 Don't use different type of cells supplied by different manufacturer together;  
请勿将不同厂家或不同种类、型号的电池以及新旧电池混用；
- 15.3 Don't charge the heating or modification cell;  
请勿将发热、气鼓、变形或漏液电池放入设备中充放电；
- 15.4 Don't let the cell over-discharge.  
在充放电时，不能超出本规格书规定的电压、电流范围。

### 16.1Reminding提醒

- 16.1 Don't use the damaged cells (the sealing edge was damaged, the pack was damaged, the electrolyte leakage, etc.). If the cell heating when using, go far away from the cell, it may avoid unnecessary damage;  
禁止使用已损坏的电芯(电芯封口封边损坏,外壳破损,闻到电解液,电解液泄漏等). 操作电池时,如果发现电池发热,要立即远离该电池以免造成不必要的伤害；
- 16.2 Theoretically, there is not flowing electrolyte in the cell, but if the leakage of electrolyte happen,or the electrolyte splash down to the skin, eyes or other parts of the body, wash with water and go to hospital immediately;  
聚合物锂离子电池理论上不存在流动的电解液,但万一有电解液泄漏而接触到皮肤、眼睛或身体其它部位,应立即用清水冲洗并就医；
- 16.3 The cells supplied by ZHAONENG Battery Industrial Co., Ltd. had passed the QC before sales,If there is any abnormal problem such as unidentified heating,expansion and peculiar smell,please contact with us;  
电池出货前已由QC严格检查，如客户发现所购电池有发热、气鼓或异味现象，请与我司联系；
- 16.4 The Pack stored beyond half year should be charged to 3.7~3.9V/cell with constant current at 0.5C .  
电池储存超过半年，请客户对电池用0.5C电流充电至单个电池电压3.7~3.9V。