

S

T

S

L

A

B



JAPAN TEST REPORT

Report No:STS1903108W01

Issued for

Particle Industries, Inc

126 Post St, 4th floor, San Francisco, CA 94108 USA

Product Name:	Boron 2G/3G
Brand Name:	N/A
Test Model Name:	BRN310
Series Model:	N/A
Test Standard:	Article 2 Paragraph 1 of Item 19, annex 43 and annex 1

Any reproduction of this document must be done in full. No single part of this document may be reproduced without permission from STS, All Test Data Presented in this report is only applicable to presented Test sample.

Shenzhen STS Test Services Co., Ltd.
1/F., Building B, Zhuoke Science Park, No.190, Chongqing Road,
Fuyong Street, Bao'an District, Shenzhen, Guangdong, China
TEL: +86-755 3688 6288 FAX: +86-755 3688 6277 E-mail: sts@stsapp.com





TEST RESULT CERTIFICATION

Applicant's name : Particle Industries, Inc
Address..... : 126 Post St, 4th floor, San Francisco, CA 94108 USA
Manufacture's Name : ABO Electronics (Shenzhen) Co., Ltd
Address..... : 2nd Floor, Building A, Block D, 99 Ind Zone, Minzhu, XiHuan Road, Shajing, Baoan, Shenzhen, PRC

Test specification:

Standard : Article 2 Paragraph 1 of Item 19, annex 43 and annex 1

Product description

Product name..... : Boron 2G/3G
 Trade mark..... : N/A
 Test model name..... : BRN310
 Series model..... : N/A

This device described above has been tested by STS, the test results show that the equipment under test (EUT) is in compliance with Article 2 Paragraph 1 of Item 19, annex 43 and annex 1 requirements. And it is applicable only to the tested sample identified in the report.

This report shall not be reproduced except in full, without the written approval of STS, this document may be altered or revised by STS, personal only, and shall be noted in the revision of the document

Testing

Date of receipt of test item : 04 Mar. 2019
 Date (s) of performance of tests : 04 Mar. 2019 ~ 21 Mar. 2019
 Date of Issue : 22 Mar. 2019
 Test Result : **Pass**

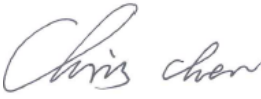
Testing Engineer : 

 (Chris chen)

Technical Manager : 

 (Sunday Hu)

Authorized Signatory : 

 (Vita Li)





Table of Contents	Page
1. SUMMARY OF TEST RESULTS	6
1.1 TEST FACTORY	7
1.2 MEASUREMENT UNCERTAINTY	7
2. GENERAL INFORMATION	8
2.1 GENERAL DESCRIPTION OF THE EUT	8
2.2 DESCRIPTION OF THE TEST MODES	10
2.3 TEST CONDITIONS	10
2.4 BLOCK DIGRAM SHOWING THE CONFIGURATION OF SYSTEM TESTED	11
2.5 DESCRIPTION OF NECESSARY ACCESSORIES AND SUPPORT UNITS	11
2.6 EQUIPMENTS LIST FOR ALL TEST ITEMS	12
3. CONSTRUCTION PROTECTION CONFIRMATION	13
4. FREQUENCY ERROR	14
4.1 LIMIT	14
4.2 TEST PROCEDURES	14
4.3 TEST SETUP	14
4.4 EUT OPERATION DURING TEST	14
4.5 TEST RESULT	15
5. ANTENNA POWER	18
5.1 LIMIT	18
5.2 TEST PROCEDURE	18
5.3 TEST SETUP	18
5.4 TEST DEVIATION	18
5.5 TEST RESULT	19
6. RADIATION POWER	20
6.1 LIMIT	20
6.2 TEST RESULT	20
7. OCCUPIED BANDWITH AND SPREAD BANDWIDTH	21
7.1 LIMIT	21
7.2 TEST PROCEDURES	21
7.3 TEST SETUP	21
7.4 TEST DEVIATION	21
7.5 EUT OPERATION DURING TEST	21



8. UNWANTED EMISSION INTENSITY MEASUREMENT	26
8.1 LIMIT	26
8.2 TEST PROCEDURES	26
8.3 TEST SETUP	27
8.4 TEST DEVIATION	27
8.5 TEST RESULT	28
9. IMITATION OF COLLATERAL EMISSION OF RECEIVER MEASUREMENT	33
9.1 LIMIT	33
9.2 TEST PROCEDURES	33
9.3 TEST RESULT	34
10. TRANSMISSION RADIATION ANGLE WIDTH (3DB BEAMWIDTH) MEASUREMENT	35
10.1 LIMIT	35
10.2 TEST PROCEDURES	35
10.3 TEST SETUP	36
10.4 TEST DEVIATION	36
10.5 EUT OPERATION DURING TEST	36
10.6 TEST RESULT	36
11. RADIO INTERFERENCE PREVENTION CAPABILITY MEASUREMENT	37
11.1 LIMIT	37
11.2 MEASURING ID CODE SOFTWARE	37
11.3 TEST PROCEDURES	37
11.4 TEST SETUP	37
11.5 TEST DEVIATION	37
11.6 EUT OPERATION DURING TEST	37
11.7 TEST RESULT OF RADIO INTERFERENCE PREVENTION CAPABILIT	38
12. CARRIER SENSE CAPABILITY	39
12.1 INTERFERENCE PREVENTION FUNCTION	39
12.2 TEST REQUIREMENT	39
12.3 TEST PROCEDURE	39
12.4 TEST RESULT	39



Revision History

Rev.	Issue Date	Report NO.	Effect Page	Contents
00	22 Mar. 2019	STS1903108W01	ALL	Initial Issue





1. SUMMARY OF TEST RESULTS

Test procedures according to the technical standards: STD-T66 V3.7

Rule Section	Description of Test	Result	judgement
3.2	Frequency Error	2.706 ppm	PASS
3.2	Occupied Bandwidth (99%) Spread-spectrum Bandwidth (90%)	1.071 MHz 0.698 MHz	PASS
3.2	Unwanted Emission Intensity	--	PASS
3.2	Power Error	-67.53%	PASS
3.3	Limitation of Collateral Emission of Receiver	--	PASS
3.6	Transmission Radiation power	N/A	N/A
3.2	Transmission Radiation Angle Width (3DB Beamwidth)	N/A	N/A
3.4	Radio Interference Prevention Capability	--	PASS
3.2	Spreading Factor	N/A	N/A
Note(2)	Carrier Sense Capability	N/A	N/A
3.7	Construction Protection Confirmation	--	PASS

NOTE:

- (1) "N/A" denotes test is not applicable in this Test Report
- (2) Article 2 Paragraph 1 of Item 19, annex 43 and annex 1
- (3) Section 4.17 Radio Equipment of Radio Stations of a Low-Power Data Communication System (Article 49.20)



1.1 TEST FACTORY

Shenzhen STS Test Services Co., Ltd.

Add. : 1/F., Building B, Zhuoke Science Park, No.190, Chongqing Road,
Fuyong Street, Bao'an District, Shenzhen, Guangdong, China

FCC Registration No.: 625569

A2LA Certificate No.: 4338.01

1.2 MEASUREMENT UNCERTAINTY

The reported uncertainty of measurement $y \pm U$, where expanded uncertainty U is based on a standard uncertainty multiplied by a coverage factor of $k=2$, providing a level of confidence of approximately **95 %**.

No.	Item	Uncertainty
1	RF output power, conducted	$\pm 0.71\text{dB}$
2	Unwanted Emissions, conducted	$\pm 0.63\text{dB}$





2. GENERAL INFORMATION

2.1 GENERAL DESCRIPTION OF THE EUT

Equipment	Boron 2G/3G	
Brand Name	N/A	
Model Name	BRN310	
Series Model	N/A	
Model Difference	N/A	
Product Description	The EUT is Boron 2G/3G	
	Operation Frequency:	2402~2480 MHz
	Modulation Type:	GFSK
	Number Of Channel:	40CH
	Antenna Designation:	Antenna A: Ceramic Antenna Antenna B: PIFA Antenna
	Antenna Gain(Peak):	Antenna A: 0 dBi Antenna B: 2 dBi
	Based on the application, features, or specification exhibited in User's Manual, the EUT is considered as an ITE/Computing Device. More details of EUT technical specification, please refer to the User's Manual.	
Channel List	Please refer to the Note 2.	
Battery	Rated Voltage: 3.7V Capacity: 1800mAh, 6.66Wh	
Hardware version	N/A	
Software version	N/A	

Note:

1. For a more detailed features description, please refer to the manufacturer's specifications or the User's Manual.



2.

Channel List for BLE							
Channel	Frequency (MHz)	Channel	Frequency (MHz)	Channel	Frequency (MHz)	Channel	Frequency (MHz)
37	2402	09	2422	18	2442	28	2462
00	2404	10	2424	19	2444	29	2464
01	2406	38	2426	20	2446	30	2466
02	2408	11	2428	21	2448	31	2468
03	2410	12	2430	22	2450	32	2470
04	2412	13	2432	23	2452	33	2472
05	2414	14	2434	24	2454	34	2474
06	2416	15	2436	25	2456	35	2476
07	2418	16	2438	26	2458	36	2478
08	2420	17	2440	27	2460	39	2480

3. Table for Filed Antenna

Ant.	Antenna Brand	Antenna Model	Antenna Type	Connector	Gain (dBi)	NOTE
A	N/A	N/A	Ceramic	N/A	0 dBi	BLE ANT.
B	N/A	N/A	PIFA	N/A	2 dBi	BLE ANT.



2.2 DESCRIPTION OF THE TEST MODES

To investigate the maximum EMI emission characteristics generates from EUT, the test system was pre-scanning tested base on the consideration of following EUT operation mode or test configuration mode which possible have effect on EMI emission level. Each of these EUT operation mode(s) or test configuration mode(s) mentioned above was evaluated respectively.

Worst Mode	Description
Mode 1	TX Mode (CH37)
Mode 2	TX Mode (CH17)
Mode 3	TX Mode (CH39)

2.3 TEST CONDITIONS

The module was tested while in a continuous transmitter/receiver mode. The EUT was tuned to a low, middle, and high channel for all tests. For all test case pre/scans were completed in all Modes to determine worst case levels.

Power Supply Voltage Fluctuation Test

Voltage Fluctuation Test	Normal Voltage
Input DC Power	3.7



2.4 BLOCK DIGRAM SHOWING THE CONFIGURATION OF SYSTEM TESTED

Mode 1:

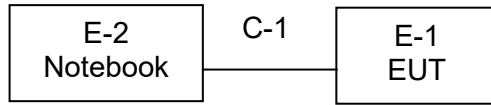

2.5 DESCRIPTION OF NECESSARY ACCESSORIES AND SUPPORT UNITS

The EUT has been tested as an independent unit together with other necessary accessories or support units. The following support units or accessories were used to form a representative test configuration during the tests.

Necessary accessories

Item	Equipment	Mfr/Brand	Model/Type No.	Serial No.	Note
N/A	N/A	N/A	N/A	N/A	N/A

Support units

Item	Equipment	Mfr/Brand	Model/Type No.	Serial No.	Note
E-2	Notebook	HP	500-320cx	N/A	N/A
C-1	USB Cable	N/A	100cm	N/A	N/A

Note:

- (1) The support equipment was authorized by Declaration of Confirmation.
- (2) For detachable type I/O cable should be specified the length in cm in 『Length』 column.
- (3) “YES” is means “shielded” “with core”; “NO” is means “unshielded” “without core”.



2.6 EQUIPMENTS LIST FOR ALL TEST ITEMS

Test equipment

Kind of Equipment	Manufacturer	Type No.	Serial No.	Last calibration	Calibrated until
USB RF power sensor	DARE	RPR3006W	15I00041SNO03	2018.10.13	2019.10.12
Signal Generator	Agilent	N5182A	MY46240556	2018.10.16	2019.10.15
Signal Analyzer	Agilent	N9020A	MY49100060	2018.10.13	2019.10.12
Wireless Communications Test Set	R&S	CMW 500	133884	2019.03.02	2020.03.01
Temperature & Humidity	HH660	Mieo	N/A	2018.10.11	2019.10.10
Temperature & Humidity test chamber	Safety test	GDS-250	171200018	2019.03.02	2020.03.01
programmable power supply	Agilent	E3642A	MY40002025	2018.10.13	2019.10.12
Attenuator	HP	8494B	DC-18G	2018.05.07	2019.05.06

Test Equipment Calibration

All of the test equipment is effective use and calibration certification institution, GRGT, the address is 163 tianhe district in huangpu road xiping cloud road .Guangzhou, China

3. CONSTRUCTION PROTECTION CONFIRMATION

Our products apply for Japanese radio frequency (rf) certification. The RF IC is sheided by the shieding cover which is welded on the PCB, it can't be removed easily.

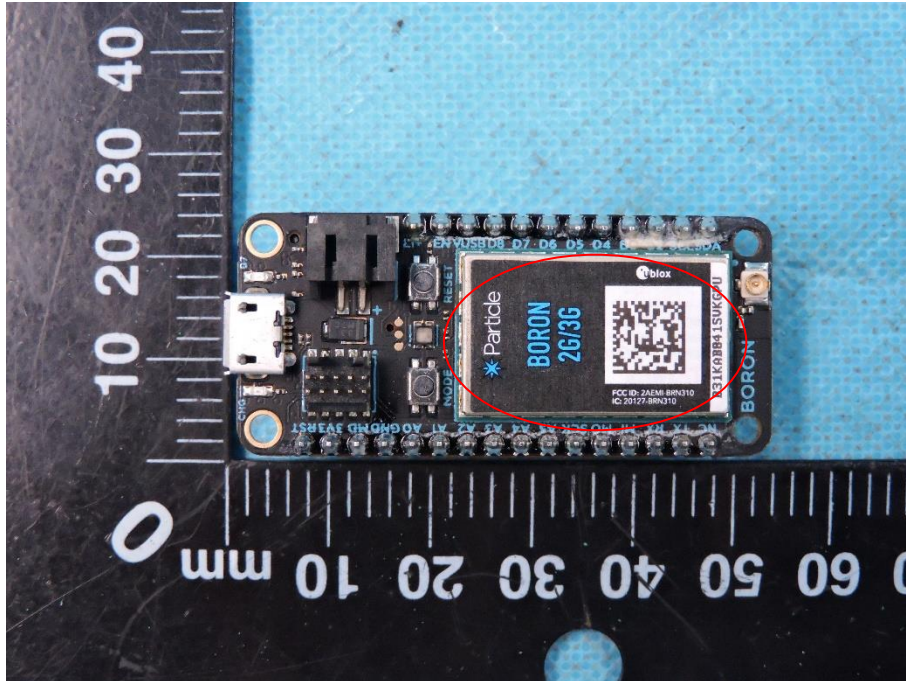

4. FREQUENCY ERROR

4.1 LIMIT

Item	Limits
Frequency Error	± 50ppm

4.2 TEST PROCEDURES

The following table is the setting of Spectrum Analyzer.

Spectrum Parameter	Setting
Attenuation	Auto
RB / VB	10KHz
Detector	Peak
Trace	Max Hold
Sweep Time	Auto

- (1) In the case of unmodulated signal (continuous or continuous burst), measure the frequency directly by a frequency meter.
- (2) In the case of burst waves, the measurement shall be done for enough time in order to obtain the enough measuring accuracy, and the average of the measured values becomes the final value.
- (3) In the case of a test mode with a specific frequency spectrum, measure the frequency of the specific spectrum by a spectrum analyzer.
- (4) In the cases above, if the frequency equivalent to the test frequency is not directly measured in principle, it shall be obtained by necessary calculation.

In the case of modulated signal, if there is no specific spectrum measurable by a spectrum analyzer but a specific dip is observed, it is allowed to measure the frequency with the signal generator (synthesized). That is, observe a signal of the signal generator concurrently (or alternately) with the tested signal using the spectrum analyzer while setting the frequency of the signal generator to the position of the dip on the screen of the spectrum analyzer, and determine the frequency of the signal generator at the time as a measured value.

4.3 TEST SETUP

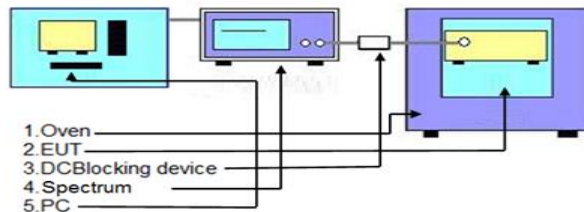

4.4 EUT OPERATION DURING TEST

The EUT was placed on the test table and programmed in un-modulation function.



4.5 TEST RESULT

Note: Antenna B power > Antenna A power, Antenna A, Antenna B all has been tested, Antenna A, Antenna B cannot transmit of the same time, only shown the worst case of Antenna B.

Temperature:	25°C	Humidity:	55 % RH
Operation Mode:	TX mode		

Antenna B

TEST CONDITIONS		Channel	F _c	Tolerance	Limit
		MHz	MHz	ppm	(ppm)
V _{nom} (V)	3.7	2402	2402.0065	2.706	±50
		2440	2440.0065	2.664	±50
		2480	2480.0065	2.621	±50





CH37 Worst Mode

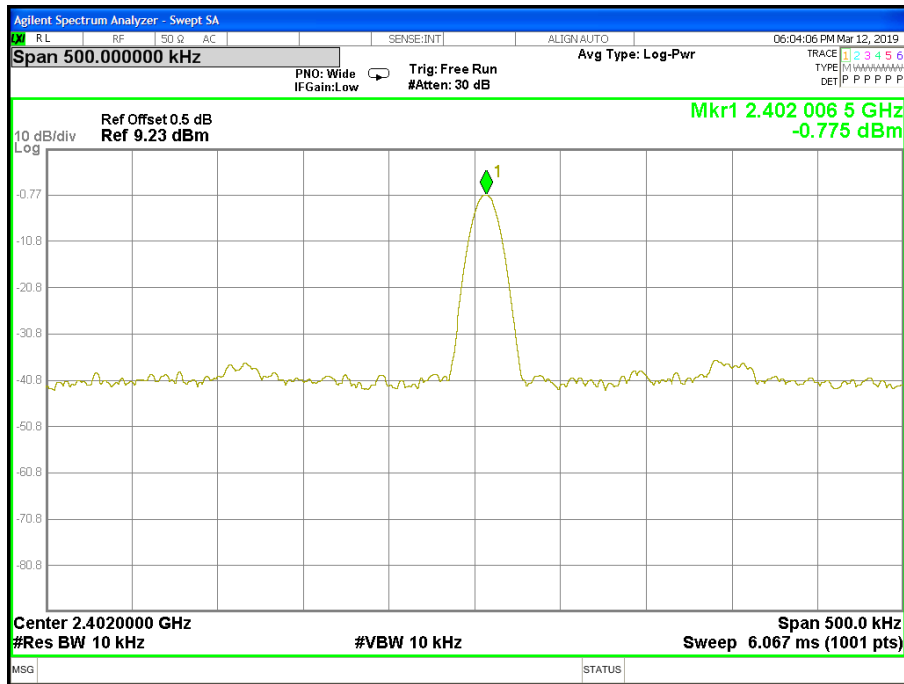

CH17 Worst Mode

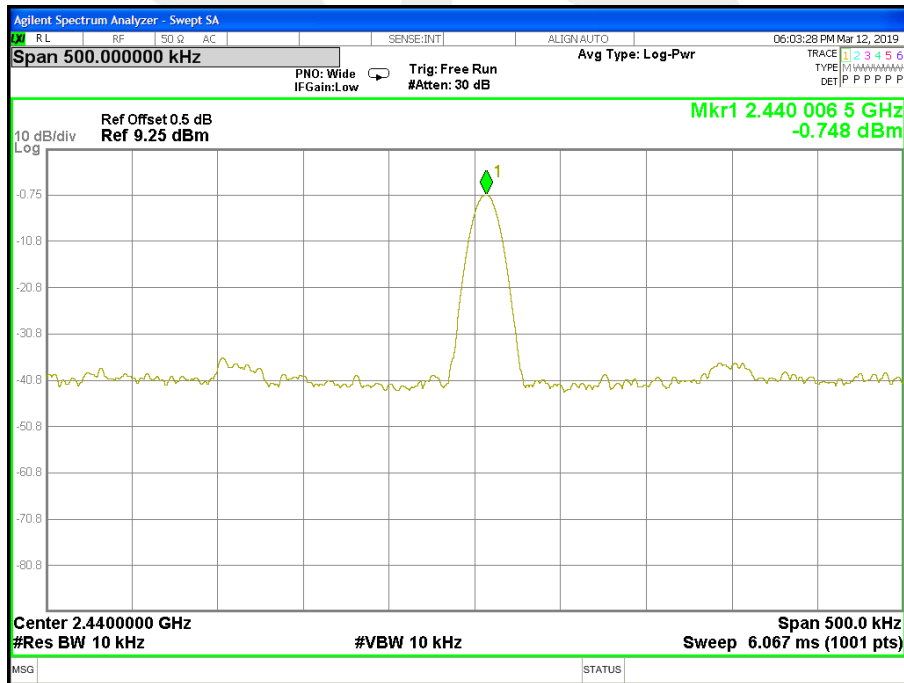



CH39 Worst Mode

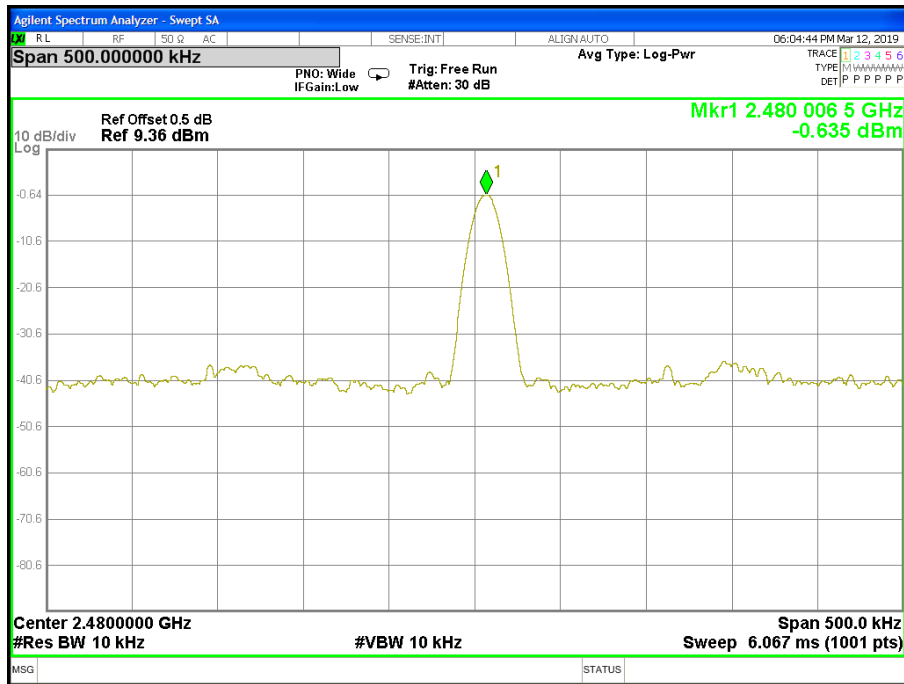

5. ANTENNA POWER

5.1 LIMIT

Item	Limits
Antenna Power Density	$\leq 3\text{mW/MHz}$ (FH form 2400 – 2483.5 MHz) $\leq 10\text{mW/MHz}$ (OFDM,DS from2400~2483.5MHz,802.11b/g/n HT20) $\leq 5\text{mW/MHz}$ (OFDM,DS from2400~2483.5MHz,802.11n HT40) $\leq 10\text{mW}$ (Other from 2400~2483.5MHz)
Power Error	+20%, -80% (Base on manufacturer declare power)

5.2 TEST PROCEDURE

1. EUT turn to test frequency channel and keep continuous transmitting
2. Reading the output power from the Power meter as P_{EUT}
3. Turn the Signal generator to frequency channel the same as the EUT
4. Turn the level of Signal generator, scan with the power meter until the power equal to P_{EUT} , the level of Signal generator recorded as "P"
5. The antenna power of EUT is "P".
6. EIRP power="P"+antenna gain

5.3 TEST SETUP

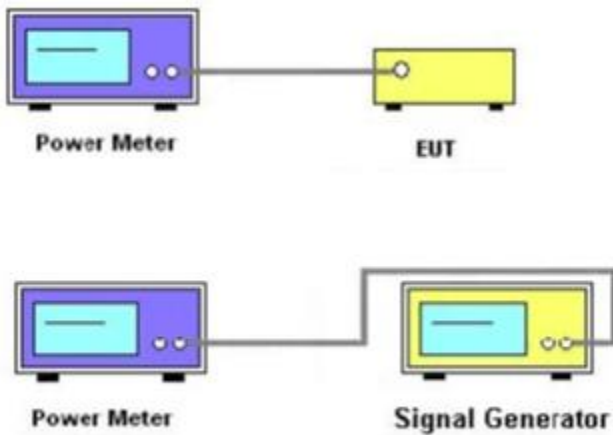

5.4 TEST DEVIATION

There is no deviation with the original standard.



5.5 TEST RESULT

Temperature:	25°C	Humidity:	55 % RH
Operation Mode:	TX mode		

Antenna Power Density

Antenna A:

TEST CONDITIONS		Channel (MHz)	Ant output POWER (dBm)	Ant output (mW)	Declared Power (mW)	Tolerance
		%				
Vnom(V)	3.7	2402	-4.885	0.325	1.0000	-67.53
		2440	-3.120	0.488	1.0000	-51.25
		2480	-1.208	0.757	1.0000	-24.28
Limit: (1) Antenna Power Density Limit (10mW) (2) Tolerance +20%, -80% (Base on manufacturer declare Antenna Power Density)						

Antenna B:

TEST CONDITIONS		Channel (MHz)	Ant output POWER (dBm)	Ant output (mW)	Declared Power (mW)	Tolerance
		%				
Vnom(V)	3.7	2402	7.388	5.480	6.0000	-8.66
		2440	7.628	5.792	6.0000	-3.47
		2480	7.618	5.778	6.0000	-3.70
Limit : (1) Antenna Power Density Limit (10mW) (2) Tolerance +20%, -80% (Base on manufacturer declare Antenna Power Density)						



6. RADIATION POWER

6.1 LIMIT

Item	Limits
Radiation power EIRP	FH form 2400 – 2483.5 MHz ,EIRP \leq 6.91dBm/MHz CCK/OFDM/DBPSK (2400~2483.5MHz) OFDM or DS other than (802.11b/g/n HT20) EIRP \leq 12.14 dBm/MHz OFDM or DS other than (802.11n HT40) EIRP \leq 9.13dBm/MHz Other from 2400~2483.5MHz: 12.14 dBm or less
Power Error	+20%, -80% (Base on manufacturer declare power)

6.2 TEST RESULT

Note: The antenna gain is less than 2.14dBi, no requirement.

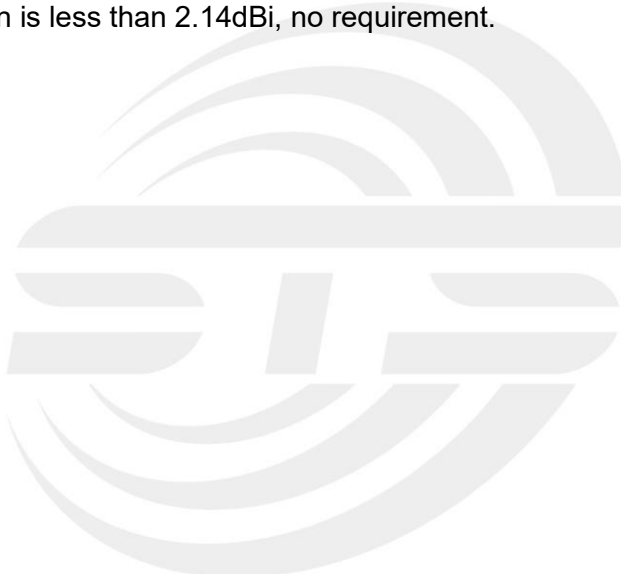

7. OCCUPIED BANDWIDTH AND SPREAD BANDWIDTH

7.1 LIMIT

Item	Limits
Occupied Band Width:	$\leq 83.5\text{MHz}$ (FH;FH+DS;FH+OFDM) $\leq 26\text{MHz}$ (Others)
Spreading Bandwidth:	$\geq 500\text{ kHz}$

7.2 TEST PROCEDURES

- Setting of SA is following as: RB: 100KHz / VB:100KHz / SPAN: 2MHz / AT: 20dB Ref:10dBm / Sweep time: Auto / Sweep Mode: Continuous sweep / Detect mode: Positive peak / Trace mode: Max hold
- EUT have transmitted the maximum modulation signal and fixed channelize (For DSSS or OFDM Device) or continuous maximum power of hopping mode(For FHSS Device). SA set to 99% of occupied bandwidth to measure occupied bandwidth. The limit is less than 26MHz(For DSSS or OFDM Device) or 83.5MHz(For FHSS Device).
- SA set to 90% of occupied bandwidth to measure Spread Spectrum Bandwidth and must greater than 500kHz.

7.3 TEST SETUP

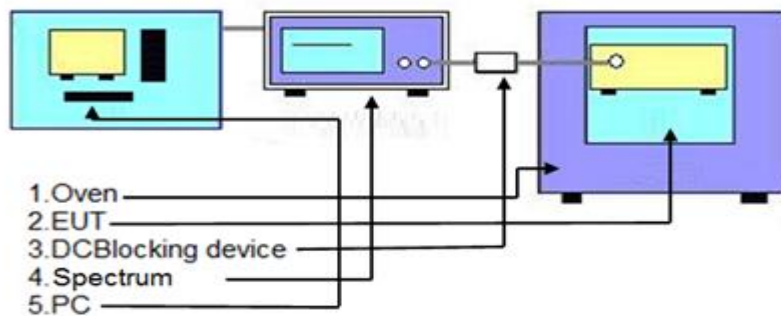

7.4 TEST DEVIATION

There is no deviation with the original standard.

7.5 EUT OPERATION DURING TEST

The EUT was programmed to be in continuously transmitting mode.



7.6 TEST RESULT

Note: Antenna B power > Antenna A power, Antenna A, Antenna B all has been tested, Antenna A, Antenna B cannot transmit of the same time, only shown the worst case of Antenna B.

Temperature:	25°C	Humidity:	55 % RH
Operation Mode:	TX mode		

Antenna B

DC Voltage		channel (MHz)	Occupied Bandwidth (MHz)	Spread Bandwidth (MHz)
Nor Voltage(V)	3.7	2402	1.067	0.696
		2440	1.068	0.697
		2480	1.071	0.698





CH37-Occupied Bandwidth (99%) Worst Mode

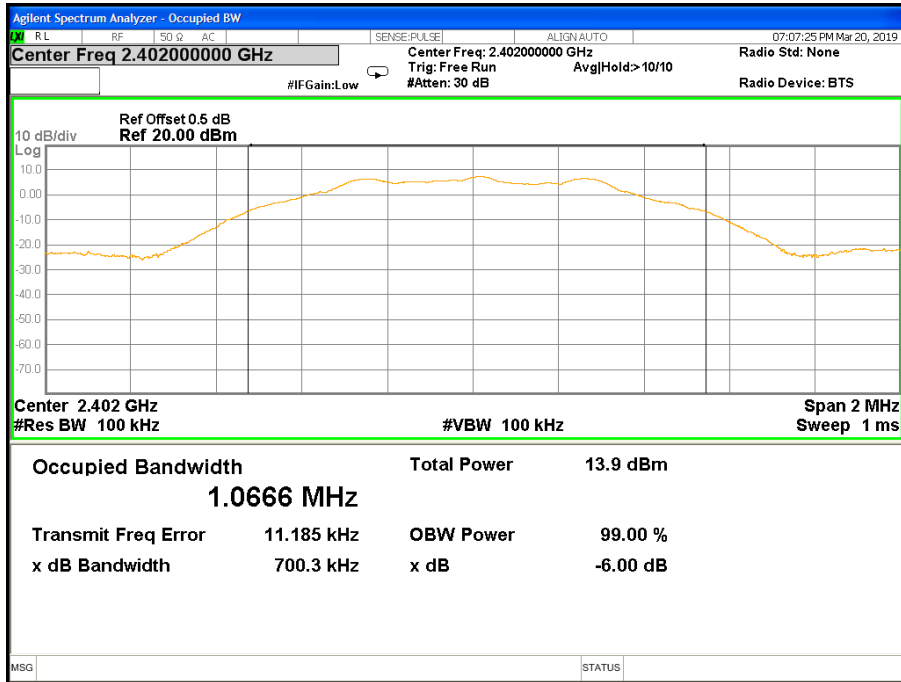

CH37-Spread Bandwidth (90%) Worst Mode

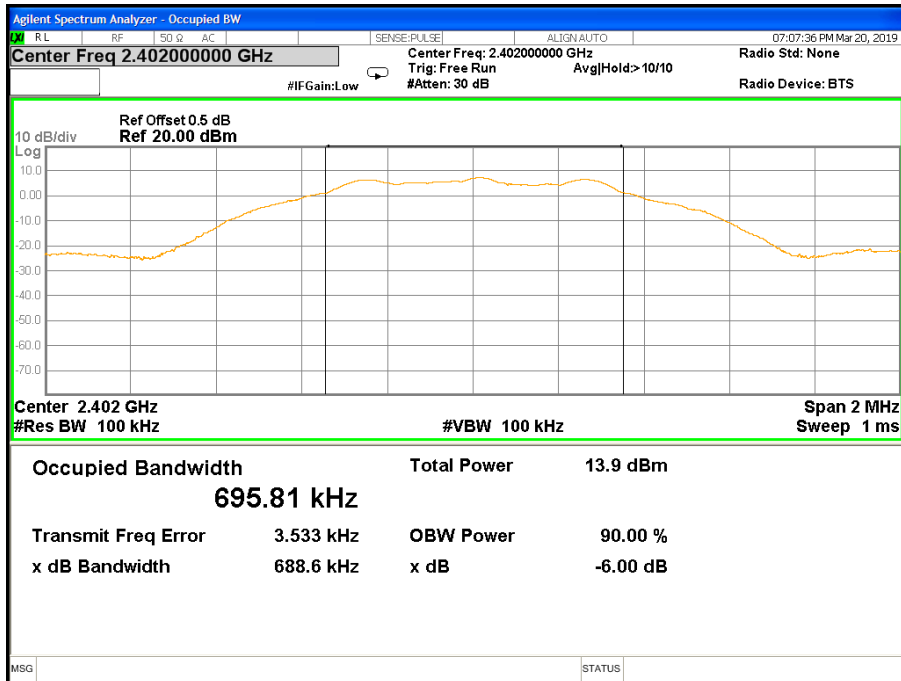



CH17-Occupied Bandwidth (99%) Mode Worst Mode

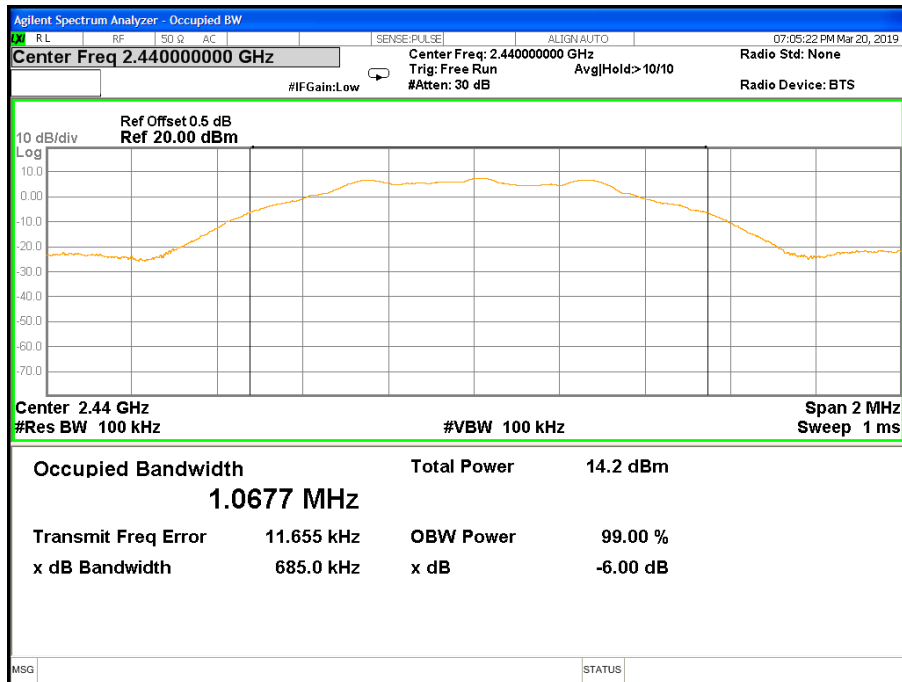

CH17-Spread Bandwidth (90%) Mode Worst Mode

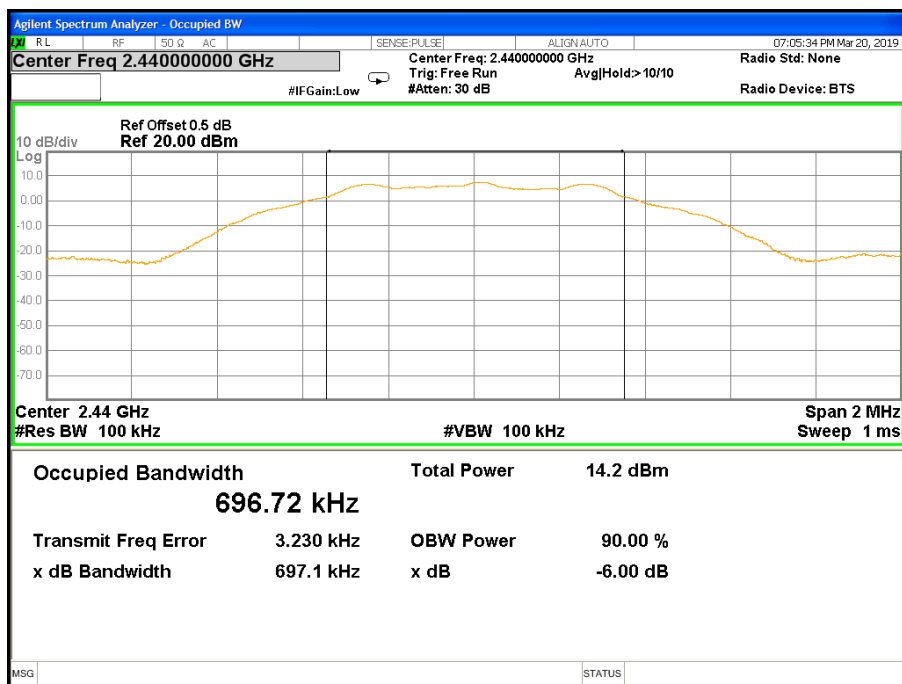



CH39-Occupied Bandwidth (99%) Worst Mode

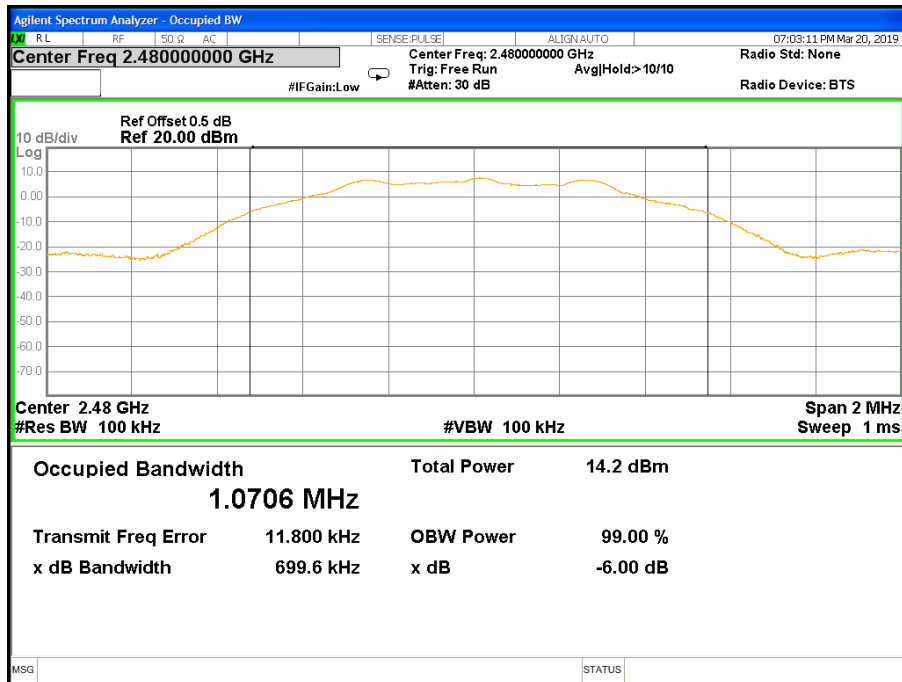

CH39-Spread Bandwidth (90%) Worst Mode

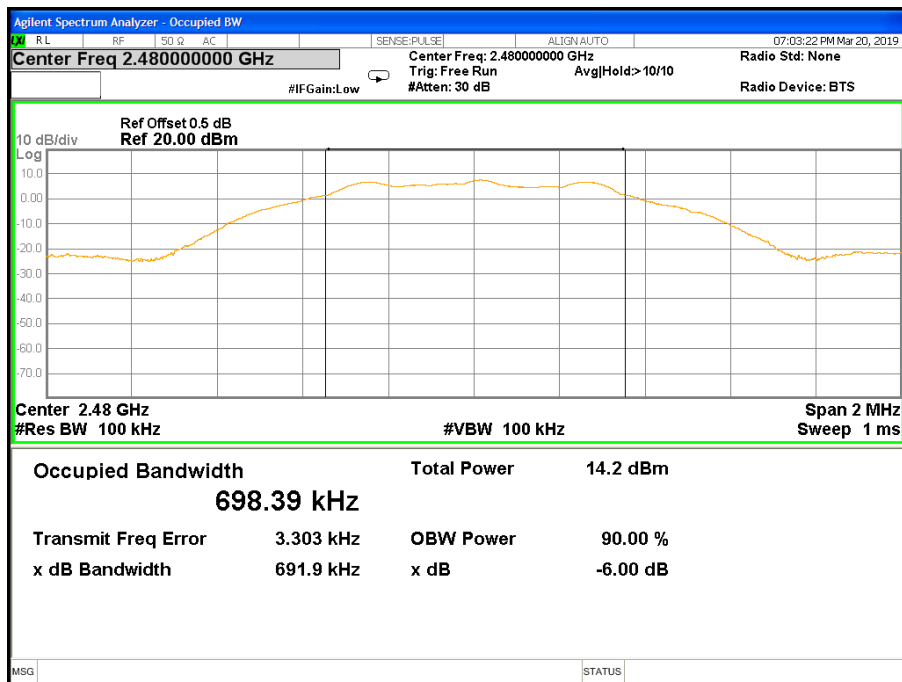



8. UNWANTED EMISSION INTENSITY MEASUREMENT

8.1 LIMIT

Item	Limits
TX Spurious Emission	$\leq 2.5 \mu\text{W}$ ($30\text{MHz} \leq f \leq 1000\text{MHz}$)
	$\leq 2.5 \mu\text{W}$ ($1000\text{MHz} < f \leq 2387\text{MHz}$)
	$\leq 25 \mu\text{W}$ ($2387\text{MHz} < f \leq 2400\text{MHz}$)
	$\leq 25 \mu\text{W}$ ($2483.5\text{MHz} \leq f < 2496.5\text{MHz}$)
	$\leq 2.5 \mu\text{W}$ ($2496.5\text{MHz} \leq f < 12500\text{MHz}$)

8.2 TEST PROCEDURES

Spectrum Parameter	Setting
Attenuation	Auto
RB / VB	100KHz / 100KHz (Below 1GHz)
RB / VB	1MHz / 1MHz (Above 1GHz)
Detector	Peak
Trace	Max Hold
Sweep Time	Auto

- EUT have transmitted the maximum modulation signal and fixed channelize.
- Setting of SA is following as: Below 1GHz RB:100KHz / VB:100KHz
Above 1GHz RB:1MHz / VB:1MHz / AT: 10dB Ref: 0dBm / Sweep time: Auto
Sweep Mode: Continuous sweep / Detect mode: Positive peak
Trace mode: Max hold
- Setting of SA is following as 30MHz and stop frequency 1000MHz Then to mark peak reading value + cable loss shall be less than 0.25 μW .
- Setting of SA is following as 1000MHz and stop frequency 2387MHz Then to mark peak reading value + cable loss shall be less than 2.5 μW .
- SA adjusted to start frequency 2387MHz and stop frequency 2400MHz. Then to mark peak reading value + cable loss shall be less than 25 μW .
- SA adjusted to start frequency 2483.5MHz and stop frequency 2496.5MHz Then to mark peak reading value + cable loss shall be less than 25 μW
- SA adjusted to start frequency 2496.5MHz and stop frequency 12750MHz Then to mark peak reading value + cable loss shall be less than 2.5 μW
- Measure side band spurious as follows: For 2.4GHz band: 2374MHz~2400MHz and 2483.5MHz~2509.5MHz RBW = VBW = 30kHz, Result_Value = Measured_Value + 15.2 [dBm]
- If the Result_Value is over the requirement, take total sum of 1MHz band centered at the spur frequency like ACLP measurement as Result_Value.

8.3 TEST SETUP

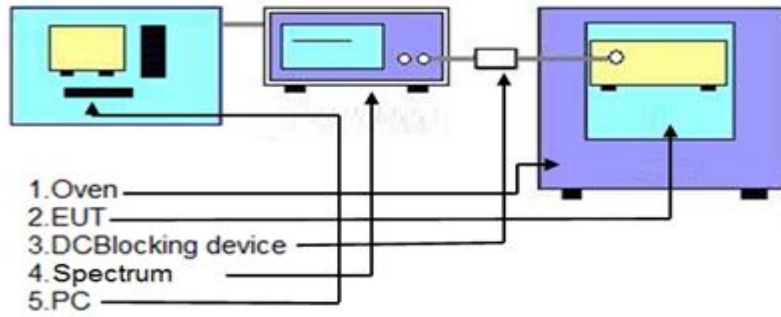

8.4 TEST DEVIATION

There is no deviation with the original standard.





8.5 TEST RESULT

Note: Antenna B power > Antenna A power, Antenna A, Antenna B all has been tested, Antenna A, Antenna B cannot transmit of the same time, only shown the worst case of Antenna B.

Temperature:	25°C	Humidity:	55 % RH
Test Voltage	Nor. Voltage	Operation Mode:	TX mode

Antenna B
CH 37 (TX mode) - Frequency Band 1 (30 MHz ≤ f ≤ 1000 MHz)
Worst Mode

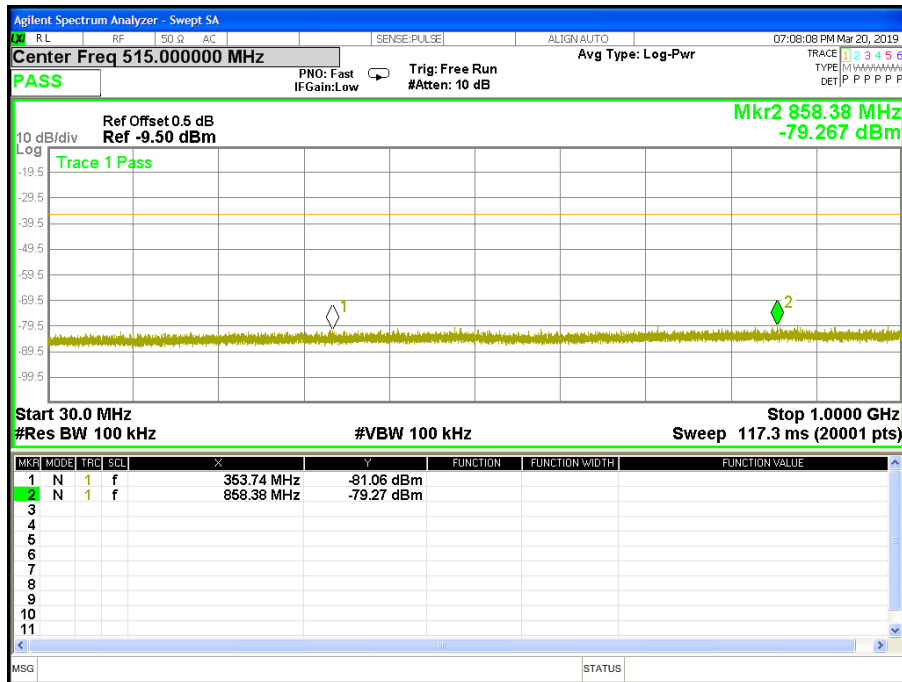



CH 37 TX mode - Frequency Band 2 (1000 MHz < f ≤ 2520 MHz) Worst Mode

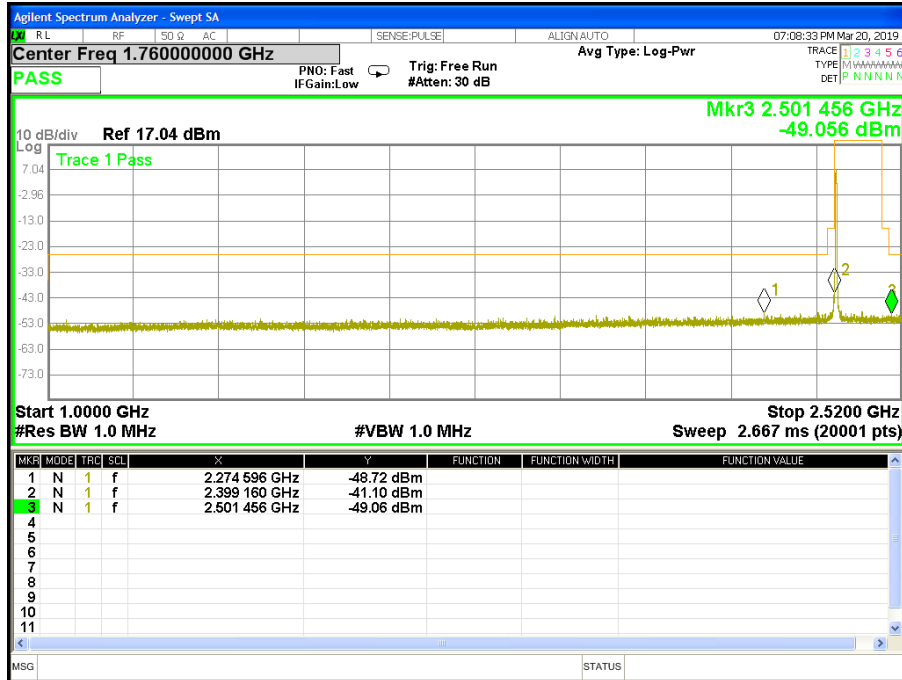

CH 37 TX mode - Frequency Band 3 (2520 MHz ≤ f < 12.75 GHz) Worst Mode

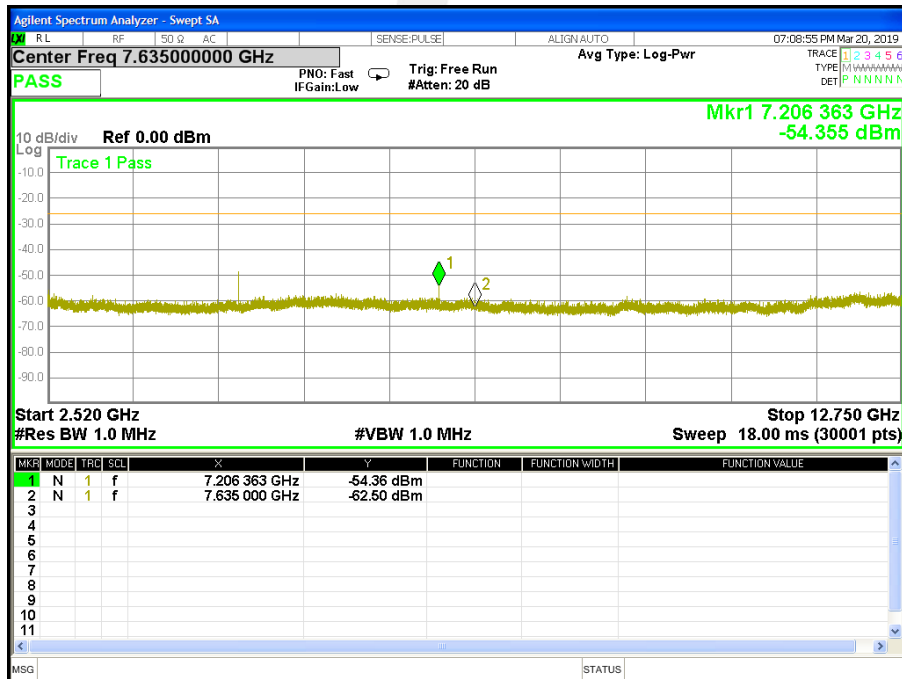



**CH 17 TX mode - Frequency Band 1 ($30 \text{ MHz} \leq f \leq 1000 \text{ MHz}$)
Worst Mode**

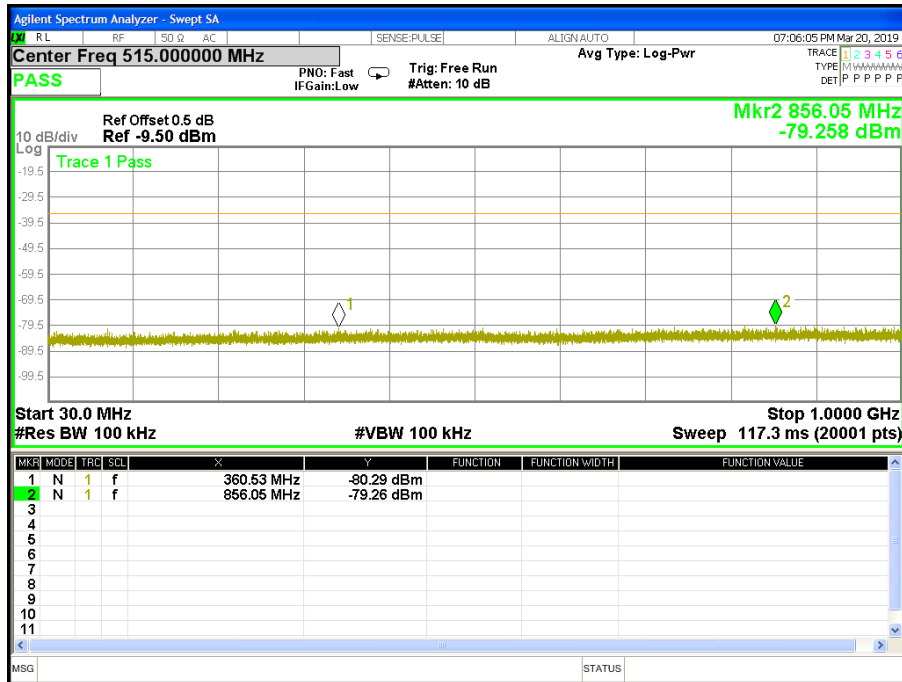

**CH 17 TX mode - Frequency Band 2 ($1000 \text{ MHz} < f \leq 2520 \text{ MHz}$)
Worst Mode**

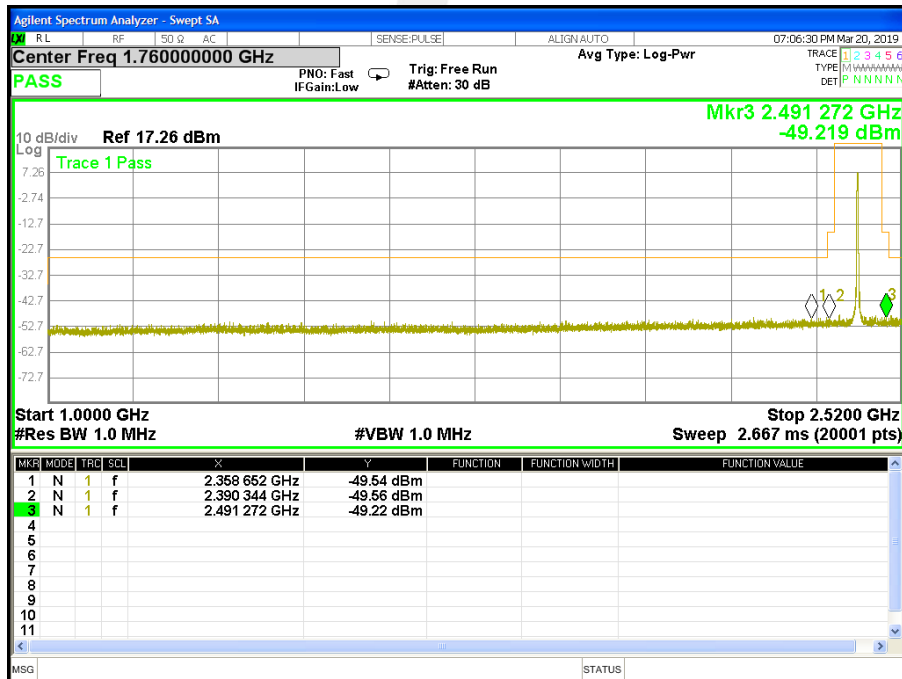



CH 17 TX mode - Frequency Band 3 (2520 MHz ≤ f < 12.75 GHz)
Worst Mode

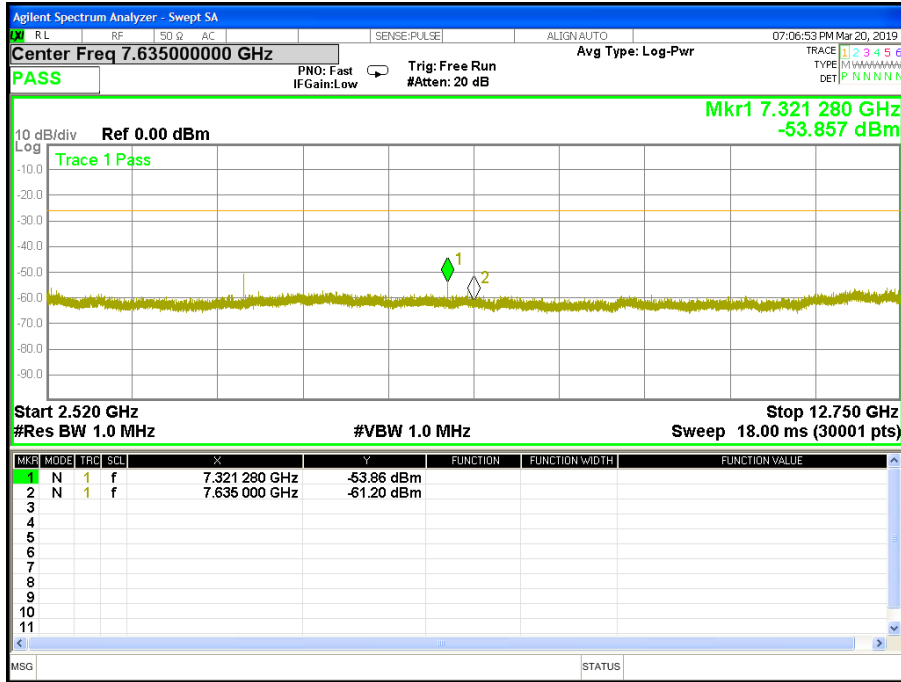

CH 39 TX mode - Frequency Band 1 (30 MHz ≤ f ≤ 1000 MHz)
Worst Mode

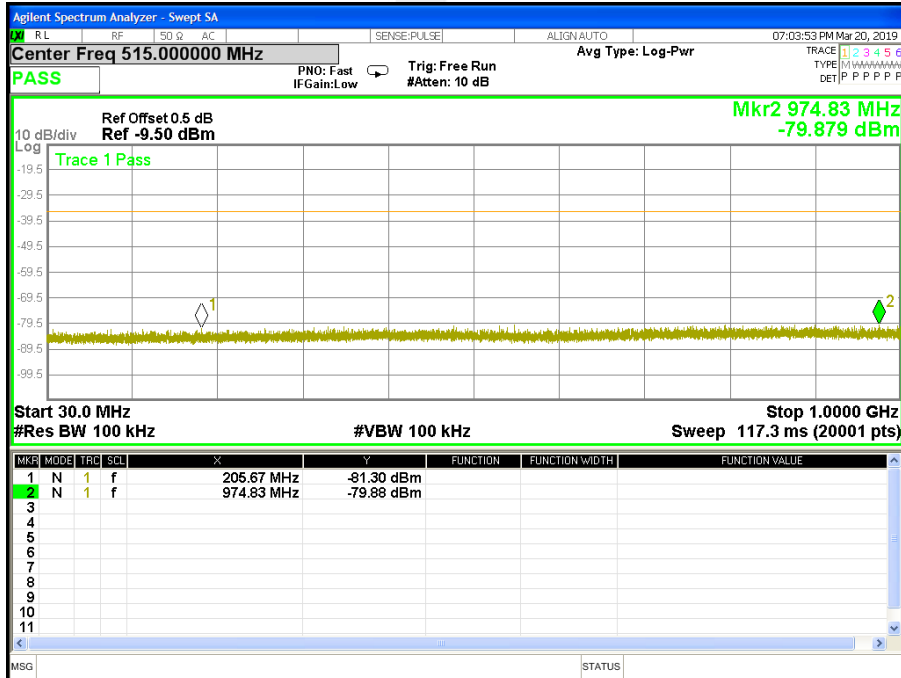



CH 39 TX mode - Frequency Band 2 (1000 MHz $f \leq 2520\text{ MHz}$) Worst Mode

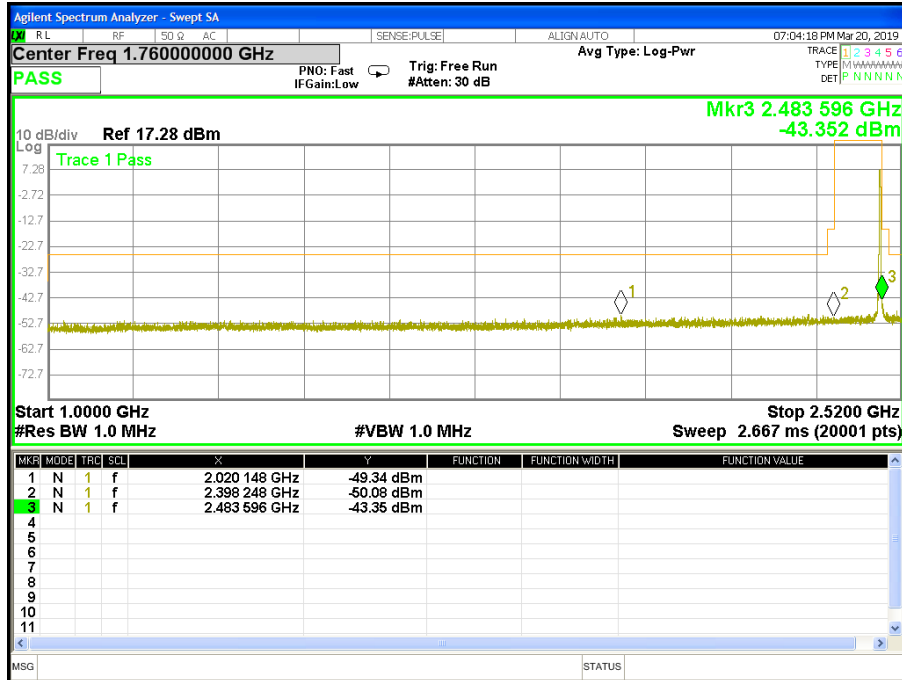

CH 39 TX mode - Frequency Band 3 (2520 MHz <math>\leq f < 12.75\text{ GHz}</math>) Worst Mode

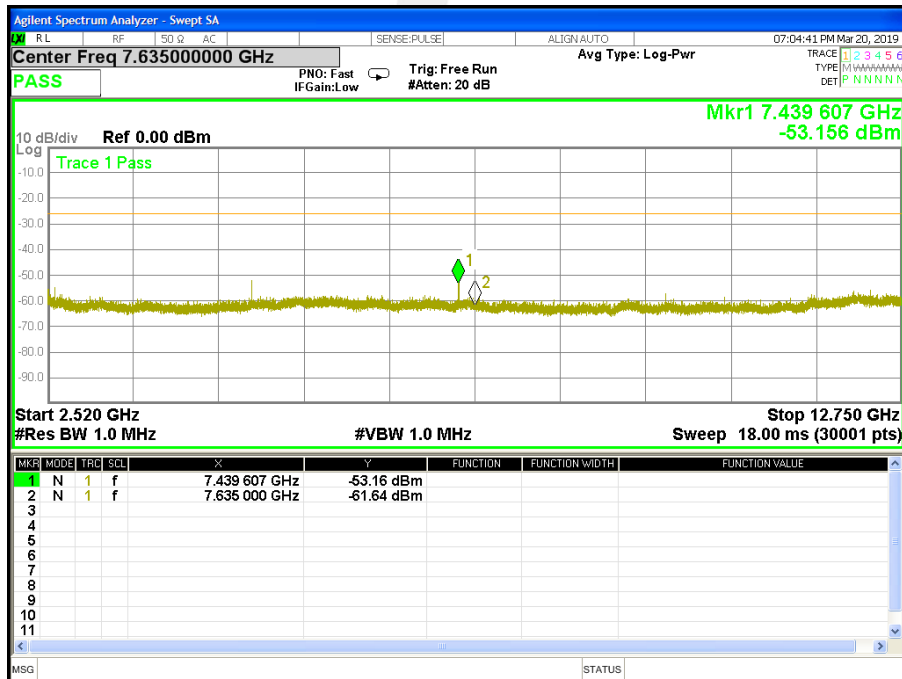



9. IMITATION OF COLLATERAL EMISSION OF RECEIVER MEASUREMENT

9.1 LIMIT

Item	Limits
RX Spurious Emission:	$\leq 4\text{nW}$ ($f < 1\text{GHz}$)
	$\leq 20\text{nW}$ ($1\text{GHz} \leq f$)

9.2 TEST PROCEDURES

The following table is the setting of Spectrum Analyzer.

Spectrum Parameter	Setting
Attenuation	Auto
RB	100 kHz (below 1GHz emissions) 1 MHz (above 1GHz emissions)
VB	100 kHz (below 1GHz emissions) 1 MHz (above 1GHz emissions)
Detector	Peak
Trace	Max Hold
Sweep Time	Auto

1. EUT have the continuous reception mode and fixed only one channelize.
2. Setting of SA is following as RB / VB: 100 kHz (below 1GHz emissions) / 1 MHz (above 1GHz emissions) /
AT: 10dB / Ref: 0dBm / Sweep time: Auto / Sweep Mode: Continuous sweep / Detect mode: Positive peak / Trace mode: Max hold
3. SA set RB: 100kHz and VB: 100kHz. Then adjust to start frequency 30MHz and stop frequency 1000MHz. Search to mark peak reading value + cable loss shall be less than 4nW
4. SA set RB: 1MHz and VB: 1MHz. Then adjust to start frequency 1000MHz and stop frequency 12750MHz. Search to mark peak reading value + cable loss shall be less than 20nW
5. If power level of lower emissions are more than 1/10 of limit (.0.4nW for $f < 1\text{GHz}$, 2nW for $f \geq 1\text{GHz}$), all those are to be indicated in the 2nd and 3rd lines. If others are 1/10 or less more of the limit, no necessary to be indicated.



9.3 TEST RESULT

Note: Antenna B power > Antenna A power, Antenna A, Antenna B all has been tested, Antenna A, Antenna B cannot transmit of the same time, only shown the worst case of Antenna B.

Temperature:	25°C	Humidity:	55 % RH
Operation Mode:	Nor. Voltage RX mode		

The worst test channel of all channels was showed as the follow:

RX-Frequency Band 1 (30 MHz ≤ f < 1000 MHz) Worst Mode

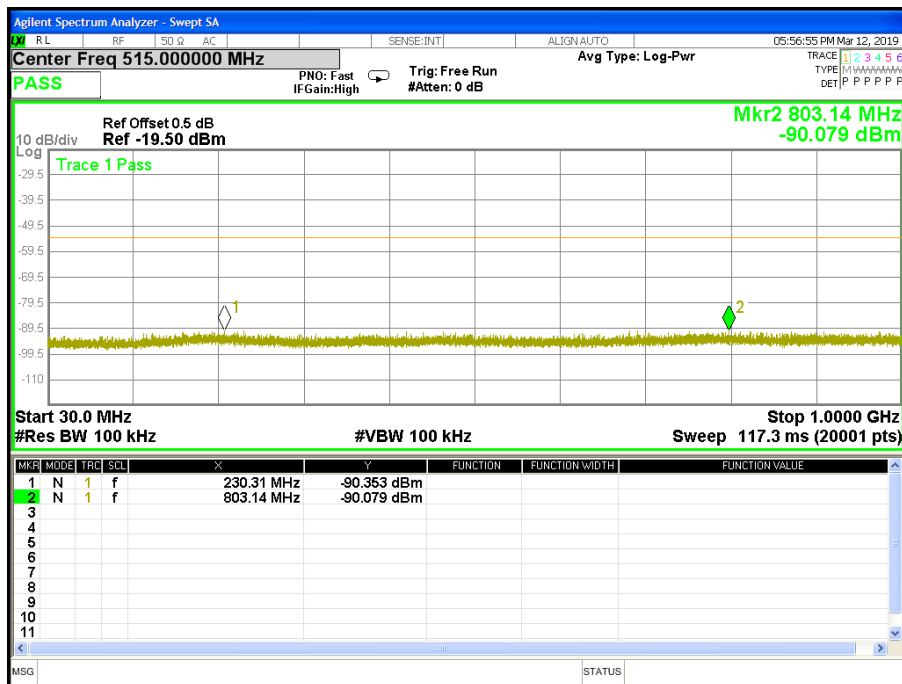

RX-Frequency Band 2 (1000 MHz ≤ f < 12750 MHz) Worst Mode

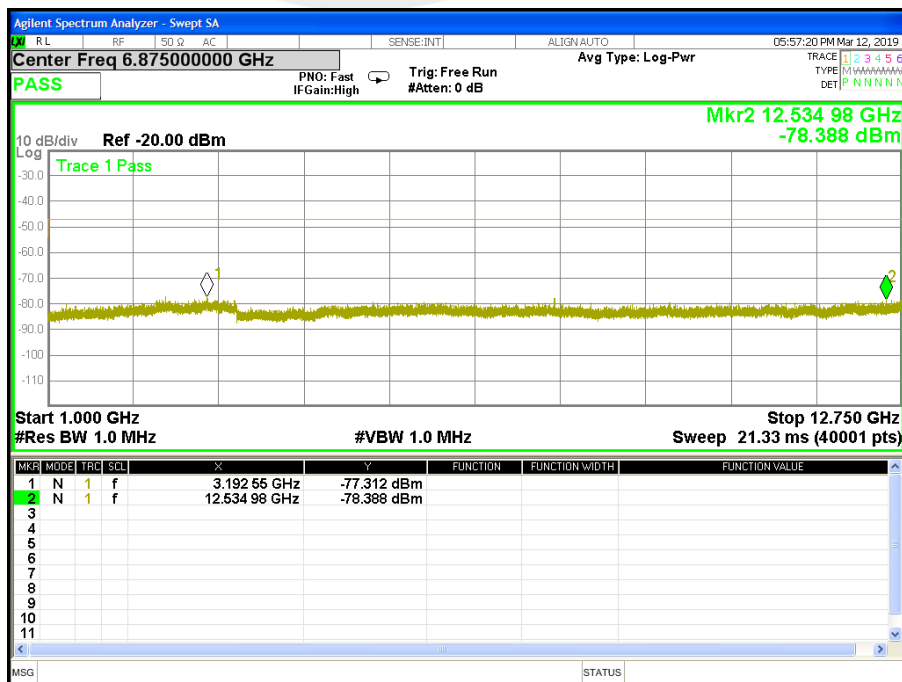



10. TRANSMISSION RADIATION ANGLE WIDTH (3DB BEAMWIDTH) MEASUREMENT

10.1 LIMIT

Item	Limits
3dB antenna beam width	$e \leq 360/A$ (The A is 10 in maximum) $A = \{EIRP \text{ Power [mW/MHz]} / \{2.14\text{dBi} + \text{output power}(10\text{mW /MHz}, 3\text{mW/MHz})\}\}$ Shall be 1 when A is lower than 1
Note: This test item is not applied for radio equipment with equivalent isotropic radiation power lower than 12.14dBm/MHz, but Antenna Power(Conducted) limit is 10 mW/MHz (10 dBm/MHz), So the test item will not be applied to the transmission antenna which has a gain of 2.14dBi or less	

10.2 TEST PROCEDURES

Spectrum Parameter	Setting
Attenuation	Auto
Span Frequency	0 MHz
RB	1 MHz
VB	1 kHz
Detector	Peak
Trace	Max Hold
Sweep Time	Auto

1. Set EUT and measuring antenna at the same height and roughly facing each other.
2. Set spectrum analyzer with condition in section 4.7.2 and tune reference level to observe receiving signal position.
3. Rotate directions of the EUT horizontally and vertically to find the maximum receiving power.
4. Move the measuring antenna height up and down within $\pm 50\text{cm}$ of EUT height and swing it to find the maximum output of measuring antenna. "E" is the half-power beam width (angle between two points at which radiated power becomes 1/2)
5. Calculate permitted radiation angle in horizontal and vertical using EIRP measured in another test method.
6. Calculate 3dB antenna beam width by the formula below $360/A$ (If $A < 1$; then $A = 1$).
 $A = \{EIRP \text{ Power [mW/MHz]} / \{2.14\text{dBi} + \text{output power}(10\text{mW /MHz}, 3\text{mW/MHz})\}\}$
 Shall be 1 when A is lower than 1

10.3 TEST SETUP

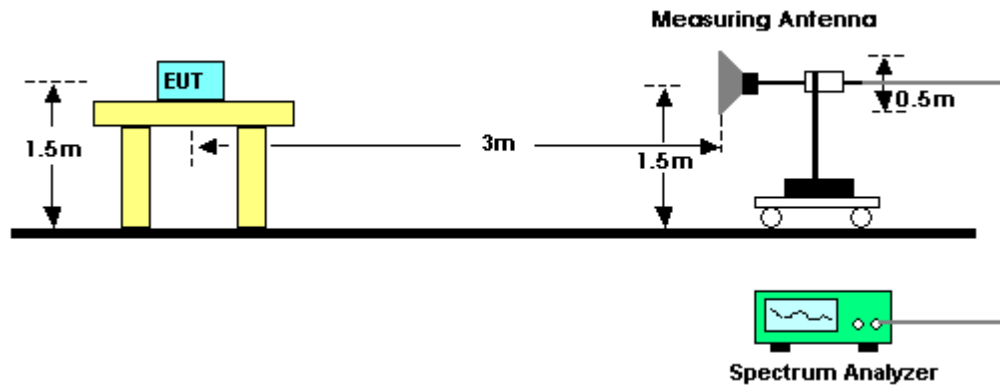

10.4 TEST DEVIATION

There is no deviation with the original standard.

10.5 EUT OPERATION DURING TEST

The EUT was programmed to be in continuously transmitting mode.

10.6 TEST RESULT

Note: The antenna gain is less than 2.14dBi, no requirement.

11. RADIO INTERFERENCE PREVENTION CAPABILITY MEASUREMENT

11.1 LIMIT

Item	Limits
Identification code	≥48 bits

11.2 MEASURING ID CODE SOFTWARE

Item	Limits
MAC IP List	MAC Scan

11.3 TEST PROCEDURES

- In the case that the EUT has the function of automatically transmitting the identification code: a. Transmit the predetermined identification codes from EUT. b. Check the transmitted identification codes with the demodulator.
- In the case of receiving the identification code: a. Transmit the predetermined identification codes from the counterpart. b. Check if communication is normal. c. Transmit the signals other than predetermined ID codes from the counterpart. d. Check if the EUT stops the transmission, or if it displays that identification codes are different from the predetermined ones.

11.4 TEST SETUP

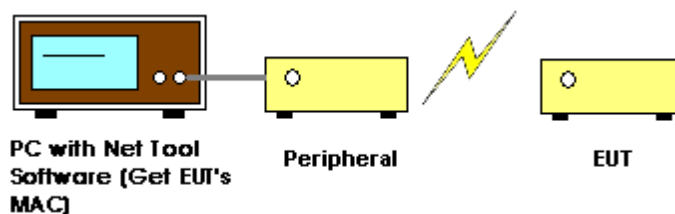

11.5 TEST DEVIATION

There is no deviation with the original standard.

11.6 EUT OPERATION DURING TEST

The EUT was programmed to be in normal transmitting mode.



11.7 TEST RESULT OF RADIO INTERFERENCE PREVENTION CAPABILIT

```
INFO:;INFO_OK:
Version: 0.4.6
Board: Boron-VRYBC2
DeviceID: e00fce68c373f3b4c646536c
MAC Address: D4:73:D8:7D:05:64
Flash ID: C22016
:INFO_DONE
```

自动滚屏 Show timestamp NL 和 CR 115200 波特率 清空输出

Note: The MAC Address is D4:73:D8:7D:05:64.



12. CARRIER SENSE CAPABILITY

12.1 INTERFERENCE PREVENTION FUNCTION

12.2 TEST REQUIREMENT

MIC Notice No.88 Appendix No.43

Article 2, Paragraph 1, Item 19 Rules Section 10

12.3 TEST PROCEDURE

1. SG adjusted the frequency as same as the EUT transmitted signal and emitted the absence of modulation from SG and power level is $(on\ 22.79+G-20*\log(f)\text{dBm})$ (G is the antenna gain, f is the test frequency).
2. turn off the RF signal of the SG.
3. EUT have transmitted the maximum modulation signal and fixed channelize.
4. Setting of SA :RBW/VBW=1MHz/1MHz, Span=50MHz, Sweep time=auto, Sweep mode=continuous, Detect mode=positive peak
5. SG RF signal on.
6. EUT shall be stop the transmitted any signal and SG RF signal off, the EUT will be continuous

❖ Measurement System Diagram

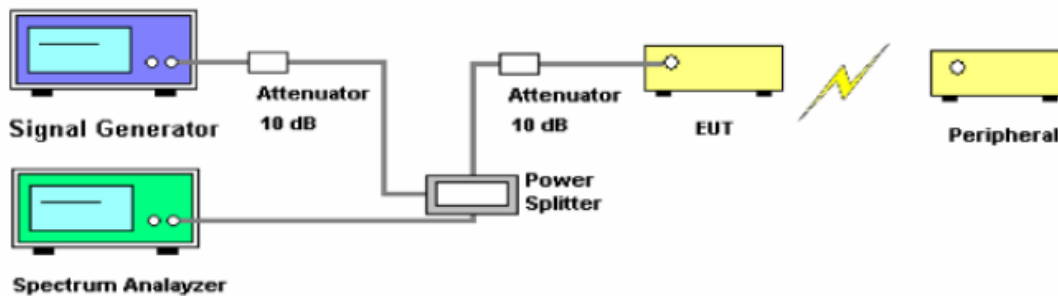

❖ Conditions of Application Equipment (EUT)

- The EUT state shall be “normal mode link with wireless router”.

12.4 TEST RESULT

Note: no requirement.



EUT TEST PHOTO

Note: See test photos in setup photo document for the actual connections between Product and support equipment.

※※※※END OF THE REPORT※※※※

