

**APPLICATION REPORT**  
**ON BEHALF OF**  
**FOSHAN ZHAONENG BATTERY INDUSTRIAL CO., LTD.**  
**LITHIUM POLYMER BATTERY**

**Model: ZN-103450**

**Prepared For :** FOSHAN ZHAONENG BATTERY INDUSTRIAL CO., LTD.  
No.8 Nanda Road, Jinsha Chengnan Industrial Zone, Danzao Town,  
Nanhai District, Foshan city, Guangdong, China

**Prepared By :** Shenzhen LCS Compliance Testing Laboratory Ltd.  
1/F., Xingyuan Industrial Park, Tongda Road, Bao'an Avenue, Bao'an  
District, Shenzhen, Guangdong, China

**Date of Test :** 2016.06.20 – 2016.06.30

**Date of Report :** 2016.06.30

**Report Number :** LCS1606221802S

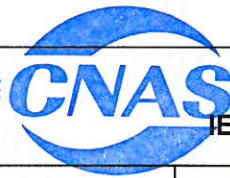
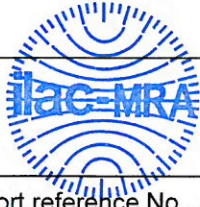

中国认可  
国际互认  
检测  
TESTING  
CNAS L4595

Battery Report

IEC 62133: 2012(2<sup>nd</sup> Edition)

Report reference No .	LCS1606221802S	
Tested by (+ signature)	Jim Deng	
Approved by (+ signature)	Hart Qiu	
Contents	28 pages	
Date of issue	2016.06.30	
Testing Laboratory Name	Shenzhen LCS Compliance Testing Laboratory Ltd.	
Address	1/F., Xingyuan Industrial Park, Tongda Road, Bao'an Avenue, Bao'an District, Shenzhen, Guangdong, China	
Testing location	Same as above	
Address	Same as above.	
Applicant's Name	FOSHAN ZHAONENG BATTERY INDUSTRIAL CO., LTD.	
Address	No.8 Nanda Road, Jinsha Chengnan Industrial Zone, Danzao Town, Nanhai District, Foshan city, Guangdong, China	
Standard	IEC 62133: 2012(2 <sup>nd</sup> Edition)	
Test procedure	Type Approval	
Procedure deviation	N/A	
Non-standard test method	N/A	
Manufacturer	FOSHAN ZHAONENG BATTERY INDUSTRIAL CO.,LTD.	
Address	No.8 Nanda Road, Jinsha Chengnan Industrial Zone, Danzao Town, Nanhai District, Foshan city, Guangdong, China	
Test item description	LITHIUM POLYMER BATTERY	
Trade Mark	ZN	
Model/type reference	ZN-103450	
Ratings	3.7V 1800mAh 6.66Wh	
Classification	Li-ion Battery	
Dimension	L : 50.00mm W: 33.56mm T : 9.55mm	
Shape	Cuboid	
Mass of apparatus	32.85g	

<b>Possible test case verdicts:</b>	
Test case does not apply to the test object.....	N/A
Test item does meet the requirement.	P(ass)
Test item does not meet the requirement.....	F(ail)
<b>Testing:</b>	
Date of receipt of test item :	2016.06.20
Date(s) of performance of test :	2016.06.20 – 2016.06.30
<b>General remarks:</b>	
<p>“(see remark #)” refers to a remark appended to the report,  “(see appended table)” refers to a table appended to the report,  Throughout this report a point is used as the decimal separator,  The test results presented in this report relate only to the object tested,  This report shall not be reproduced except in full without the written approval of the testing laboratory,  Clause numbers between brackets refer to clauses in IEC 62133(Optional remark).</p>	

**General product information:**

The battery, model no.: ZN-103450 is used in portable applications and consists of one Li-ion cell, the cell model no.: 103450

The cells and batteries have been tested and evaluated according to their specified working conditions (as given below), which are provided by client;

Details information of the battery and the cell built in the battery, as following:

Product	LITHIUM POLYMER CELL	LITHIUM POLYMER BATTERY
Model No.	103450	ZN-103450
Nominal voltage	3.7V	3.7V
Rated capacity	1800mAh	1800mAh
Charge method	0.2C constant current charge to 4.2V, then constant voltage until the charge current decrease to 0.01C.	0.2C constant current charge to 4.2V, then constant voltage until the charge current decrease to 0.01C.
Charging Current	180mA	180mA
Max. Charging Current	540mA	540mA
Maximum Discharge Current	1800mA	Protective plate to allow the maximum discharge current 6000mA
Max. Charging voltage	4.2V	4.2V
End of discharge voltage	3.0V	3.0V
Dimension	50.00*33.50*9.55mm	50.00*33.56*9.55mm
Weight	34g	37g
Lower charge temperature	10°C	
Upper charge temperature	45°C	

<p><b>Tests Performed (name of test and test clause):</b></p> <p>Tests are made with the number of samples specified in Table 2 of IEC 62133:2012(2<sup>nd</sup> Edition).</p> <p>Test items:</p> <ul style="list-style-type: none"> <li>Cl.6 type test conditions</li> <li>Cl.8.1 Charging procedures for test purposes</li> <li>Cl.8.2.1 Continuous charging at constant voltage (cells)</li> <li>Cl.8.2.2 Moulded case stress at high ambient temperature (battery)</li> <li>Cl.8.3.1 External short circuit(cell)</li> <li>Cl.8.3.2 External short circuit(battery)</li> <li>Cl.8.3.3 Free fall</li> <li>Cl.8.3.4 Thermal abuse (cells)</li> <li>Cl.8.3.5 Crush(cells)</li> <li>Cl.8.3.6 Over-charging of battery</li> <li>Cl.8.3.7 Forced discharge(cells)</li> <li>Cl.8.3.8 Transport</li> <li>Cl.8.3.9 Forced internal short circuit(cells)</li> </ul>	<p><b>Testing Location:</b></p> <p>1/F., Xingyuan Industrial Park, Tongda Road, Bao'an Avenue, Bao'an District, Shenzhen, Guangdong, China</p>
---	--

**Test conclusion:**

The LITHIUM POLYMER BATTERY submitted by FOSHAN ZHAONENG BATTERY INDUSTRIAL CO., LTD. are tested according to IEC 62133: 2012(2<sup>nd</sup> edition) Secondary cells and batteries containing alkaline or other non-acid electrolytes Safety requirements for portable sealed secondary cells, and for batteries made from them, for use in portable applications.

**Test result: Pass.**

Version	Report No.	Revision Data	Summary
V1.0	LCS1606221802SS	/	Original Version

Copy of marking plate: (N/A)

ZN-103450  
 3.7V 1800mAh 6.66Wh 1ICP10/34/52  
 RED(+) Black(-) 201606

Circuit diagram:

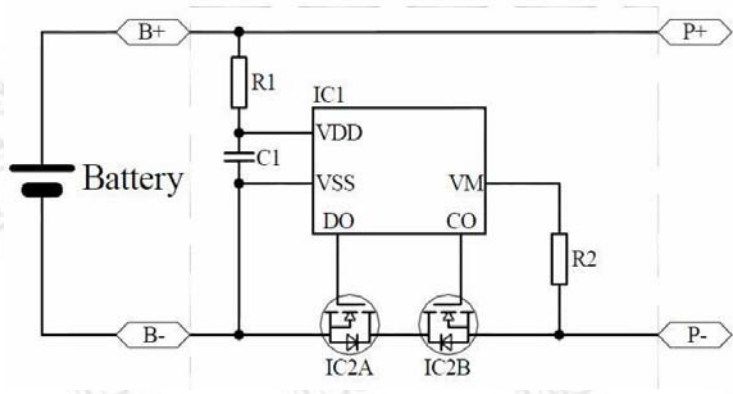

Critical components information :

Item 序号	Reference 名称	Material name 规格	Model/Specification 描述	Quantity 用量
1	Cell 电芯	103451	3.7V 1800 mAh	1
2	PCM 保护板	ZN-Pcm	9.9*34.5*52mm	1
3	Red wire 红线	UL1007 22# 硅胶 线	Red	1
4	Black wire 黑线	UL1007 22# 硅胶 线	Black	1

## IEC 62133: 2012

Clause	Requirement – Test	Result – Remark	Verdict
<b>5</b>	<b>General safety considerations</b>		P
	Cells and batteries subject to intended use be safe and continue to function in all respects	Refer to the following clauses.	P
	Cells and batteries subject to reasonably foreseeable misuse do not present significant hazards.	Refer to the following clauses.	P
5.2	Insulation and wiring		P
	–Insulation Resistance between an accessible metal case (excluding electrical contacts) and positive terminals $\geq 5M\Omega$ .		N/A
	Internal wiring and insulation are sufficient to withstand maximum anticipated current, voltage and temperature requirements	See tests of clause 8.	P
	Orientation of wiring maintains adequate creepage and clearance distances between conductors. Mechanical integrity of internal connections is sufficient to accommodate conditions of reasonably foreseeable misuse.	See tests of clause 8.	P
5.3	Venting		P
	Battery cases and cells incorporate a pressure relief mechanism or are constructed so that they relieve excessive internal pressure at a value and rate that will preclude rupture, explosion and self-ignition.		P
	Encapsulation used to support cells within an outer casing does not cause the battery to overheat during normal operation no inhibit pressure relief.		N/A
5.4	Temperature/voltage/current management		P
	The batteries are designed such that abnormal temperature rise conditions are prevented.		P
	Means is provided to limit current to safe levels during charge and discharge.		P
	The batteries are designed such that within temperature, voltage and current limits specified by the cell manufacturer.		P
	Batteries provided with specifications and charging instructions for equipment manufacturers so that associated chargers are designed to maintain charging within the temperature, voltage and current limits specified;	See battery specifications;	P
5.5	Terminal contacts		P
	Terminals have a clear polarity marking on the external surface of the battery	“+” for positive polarity and “-” for negative polarity marking on the label near the terminal	P
	The size and shape of the terminal contacts ensure that		P

## IEC 62133: 2012

Clause	Requirement – Test	Result – Remark	Verdict
	they can carry the maximum anticipated current.		
	External terminal contact surfaces are formed from conductive materials with good mechanical strength and corrosion resistance.		P
	Terminal contacts are arranged to minimize the risk of short circuits.		P
	the external connector prevents reverse polarity connections, Battery packs with keyed external connectors designed for connection to specific end products need not be marked with polarity marking;		P
5.6	Assembly of cells into batteries	Single cell battery	P
5.6.1	Cells used in the battery assembly have closely matched capacities, are of the same design, and are of the same chemistry and same manufacturer.		N/A
	The battery incorporates separate circuitry to prevent cell reversal from uneven charges as the pack is designed for the selective discharge of a portion of its series connected cells.		N/A
5.6.2	Design recommendation for lithium system only		P
	The voltage of each cell or each cellblock consisting of parallel-connected plural cell, should not exceed 4.20V, excepting the case where the portable electronic devices or the likes have the equivalent function;		N/A
	Considered at the battery pack level and by the device designer:	See below;	P
	- for the battery consisting of a single cell or a single cellblock		N/A
	- for the battery consisting of series-connected plural single cells or series-connected plural cellblocks, it is recommended that the voltages of any one of the single cells or single cellblocks does not exceed the upper limit of the charging voltage, specified in Table 4, by monitoring the voltage of every single cell or the single cellblocks;		N/A
	- for the battery consisting of series-connected plural single cells or series-connected plural cellblocks, it is recommended that charging is stopped when the upper limit of the charging voltage is exceeded for any one of the single cells or single cellblocks by measuring the voltage of every single cell or the single cellblocks.		N/A
5.7	Quality plan		P
	The manufacture has prepared a quality plan defining the procedures for the inspection of materials, components, cells and batteries and which covers the	The manufacturer has ISO 9001:2008 certificate and such quality plan.	P



## IEC 62133: 2012

Clause	Requirement – Test	Result – Remark	Verdict
	process of producing each type of cell and battery.		

<b>6</b>	<b>Type test conditions</b>		P
	Tests were conducted with the number of cells or batteries as outlined in Table 2 of IEC 62133 with cells or batteries that were not more than six months old.	Tests are made with the number of batteries specified in Table 2. battery are not more than six months old.	P
	Unless noted otherwise in the test methods, testing was conducted in an ambient of 20°C ± 5°C.	Tests are carried out at 20°C ± 5°C.	P

<b>7</b>	<b>Specific requirements and tests (nickel systems)</b>		N/A
7.1	Charging procedure for test purposes		N/A
7.2	Intended use		N/A
7.2.1	Continuous low-rate charging (cells)		N/A
	Fully charged cells are subjected for 28 days to a charge as specified by the manufacturer.		
	Results: No fire. No explosion		N/A

Sample No.	Model	Recommended Charging Method, CC, CV, or CC/CV	Recommended Charging Voltage Vc, Vdc	Recommended Charging Current Irec, mA	OCV at Start of Test, Vdc	Results
—	—	—	—	—	—	—
—	—	—	—	—	—	—
—	—	—	—	—	—	—
—	—	—	—	—	—	—
—	—	—	—	—	—	—

supplementary information:

- NF: No Fire
- NE: No Explosion
- NL: No Leakage
- Fire: the emission of flames from a cell or battery.
- Explosion: failure that occurs when a cell container or battery case opens violently and major components are forcibly expelled.
- Leakage: visible escape of liquid electrolyte.

7.2.2	Vibration		N/A
	Fully charged cells or batteries are subjected to a		N/A

IEC 62133: 2012

Clause	Requirement – Test	Result – Remark	Verdict
--------	--------------------	-----------------	---------

	vibration sequence as outlined in Table 3 of IEC 62133:2012 with amplitude of 0.76 mm and a total maximum excursion of 1.52 mm. The frequency was varied at the rate of 1 Hz/min between the limits of 10 Hz and 55 Hz. The entire range of frequencies (10 Hz to 55 Hz) and return (55 Hz to 10 Hz) was traversed in 90 min ±5 min for each mounting position.		
	Results: No fire. No explosion. No leakage		N/A

Sample No.	OCV at Start of Test, Vdc	Results
—	—	—
—	—	—
—	—	—
—	—	—
—	—	—
—	—	—
—	—	—
—	—	—
—	—	—
—	—	—

supplementary information:

- No Fire or Explosion
- No Leakage
- Leakage
- Fire
- Explosion
- Bulge
- Other (Please Explain)

7.2.3	Moulded case stress at high ambient temperature		N/A
	Fully charged batteries were placed in an aircirculating oven at a temperature of 70°C ±2°C for 7 hours.		N/A
	Results: No physical distortion of the battery casing resulting in exposure if internal components		N/A
Sample No.	—	—	—
Status	—	—	—

supplementary information:

- No Fire or Explosion
- No Leakage
- Leakage
- Fire
- Explosion

IEC 62133: 2012

Clause	Requirement – Test	Result – Remark	Verdict
--------	--------------------	-----------------	---------

- Bulge  
 - Other (Please Explain): No physical distortion of the battery casing resulting in exposure if internal components

7.2.4	Temperature cycling		N/A
	Fully charged cells or batteries are subjected to temperature cycling (-20 °C, +75 °C), in forced draught chambers. After the fifth cycle, the cells or batteries were stored for 24h prior to examination.		N/A
	Results: No fire. No explosion. No leakage.		N/A

Sample No.	—	—	—	—	—
Results	—	—	—	—	—
Sample No.	—	—	—	—	—
Results	—	—	—	—	—

supplementary information:  
 - No Fire or Explosion  
 - No Leakage  
 - Leakage  
 - Fire  
 - Explosion  
 - Bulge  
 - Other (Please Explain)

7.3	Reasonably foreseeable misuse		N/A
7.3.1	Incorrect installation cell		N/A
	The test was carried out using: - Four fully charged cells of the same brand, type, size and age connected in series, with one of them reversed; or		N/A
	- A stabilized dc power supply.		N/A
	Results: No fire. No explosion..... :		N/A

Sample No.	OCV at Start of Test, Vdc	Results
—	—	—
—	—	—
—	—	—
—	—	—
—	—	—

supplementary information:  
 - No Fire or Explosion  
 - No Leakage

IEC 62133: 2012

Clause	Requirement – Test	Result – Remark	Verdict
--------	--------------------	-----------------	---------

- Leakage - Fire - Explosion - Bulge - Other (Please Explain)
---

7.3.2	External short circuit		N/A
	The cells or batteries were tested until one of the following occurred: - 24 hours elapsed; or		N/A
	- The case temperature declined by 20% of the maximum temperature rise		N/A
	Results: No fire. No explosion..... :		N/A

Sample No.	Ambient temperature (At 20°C ± 5°C)	OCV at start of test (Vdc)	Maximum case temperature rise ΔT, (°C)	Resistance of Circuit (mΩ)	Results	N/A
—	—	—	—	—	—	—
—	—	—	—	—	—	—
—	—	—	—	—	—	—
—	—	—	—	—	—	—
—	—	—	—	—	—	—

Sample No.	Ambient temperature (At 55°C ± 5°C)	OCV at start of test (Vdc)	Maximum case temperature rise ΔT, (°C)	Resistance of Circuit (mΩ)	Results	N/A
—	—	—	—	—	—	—
—	—	—	—	—	—	—
—	—	—	—	—	—	—
—	—	—	—	—	—	—
—	—	—	—	—	—	—

supplementary information:  - No Fire or Explosion - No Leakage - Leakage - Fire - Explosion - Bulge - Other (Please Explain)
---

7.3.3	Free fall		N/A
	Each fully charged cell or battery is dropped three times from a height of 1.0m onto a concrete floor. The cells or batteries are dropped so as to obtain impacts in random orientations.		N/A
	Results: No fire. No explosion.		N/A

## IEC 62133: 2012

Clause	Requirement – Test	Result – Remark	Verdict
Sample No.	—	—	—
Results	—	—	—
Sample No.	—	—	—
Results	—	—	—
supplementary information:			
<ul style="list-style-type: none"> <li>- No Fire or Explosion</li> <li>- No Leakage</li> <li>- Leakage</li> <li>- Fire</li> <li>- Explosion</li> <li>- Bulge</li> <li>- Other (Please Explain)</li> </ul>			

7.3.4	Mechanical shock (crash hazard)		N/A
	Fully charged cells or batteries were subjected to a total of three shocks of equal magnitude applied in each of three mutually perpendicular directions. At least on of the directions was perpendicular to a flat face. During the initial 3 milliseconds, the minimum average acceleration was 75 g <sub>n</sub> . The peak acceleration was between 125 g <sub>n</sub> and 175 g <sub>n</sub> .		N/A
	Results: No fire. No explosion. No leakage.		N/A
Sample No.	—	—	—
Results	—	—	—
Sample No.	—	—	—
Results	—	—	—
supplementary information:			
<ul style="list-style-type: none"> <li>- No Fire or Explosion</li> <li>- No Leakage</li> <li>- Leakage</li> <li>- Fire</li> <li>- Explosion</li> <li>- Bulge</li> <li>- Other (Please Explain)</li> </ul>			

7.3.5	Thermal abuse		N/A
	Fully charged cells were placed in a gravity or circulating air-convection oven. The oven temperature was raised at a rate of 5°C/min ± 2°C/min to a temperature of 130°C ± 2°C. The cell remained at that temperature for 10 minutes before the test was discontinued.		N/A
	Results: No fire. No explosion.		N/A
Sample No.	—	—	—

IEC 62133: 2012

Clause	Requirement – Test	Result – Remark	Verdict
--------	--------------------	-----------------	---------

Results	—	—	—	—	—
supplementary information: - No Fire or Explosion - No Leakage - Leakage - Fire - Explosion - Bulge - Other (Please Explain)					

7.3.6	Crushing of cells			N/A
	Fully charged cells were crushed between two flat surfaces with a hydraulic ram exerting a force of 13 kN ±1 kN.			
	The crushing is performed in a manner that will cause the most adverse result.			N/A
	- Once the maximum force has been applied,			N/A
	- or an abrupt voltage drop of one-third of the original voltage has been obtained,			
	The cell is prismatic type and a second set of samples was tested, rotated 90° around longitudinal axis compared to the first set			N/A
	Results: No fire. No explosion..... :			N/A
Model	OCV at start of test, (Vdc)	OCV at removal of crushing force, (Vdc)	Results	N/A
—	—	—	—	—
—	—	—	—	—
—	—	—	—	—
—	—	—	—	—
—	—	—	—	—

supplementary information: - No Fire or Explosion - No Leakage - Leakage - Fire - Explosion - Bulge - Other (Please Explain)				
---	--	--	--	--

7.3.7	Low pressure			N/A
	Each fully charged cell is placed in a vacuum chamber, in an ambient temperature of 20°C ±5°C, its internal			N/A

IEC 62133: 2012

Clause	Requirement – Test	Result – Remark	Verdict
	pressure is gradually reduced to a pressure equal to or less than 11.6kPa held at that value for 6h		
	Results: No fire. No explosion. No leakage.		N/A
Sample No.	—	—	—
Results	—	—	—
supplementary information:			
- No Fire or Explosion - No Leakage - Leakage - Fire - Explosion - Bulge - Other (Please Explain)			

7.3.8	Overcharge		N/A				
	A discharged cell or battery is subjected to a high-rate charge of 2.5 times the recommended charging current for a time that produces a 250% charge input (250% of rated capacity).		N/A				
	Results: No fire. No explosion..... :		N/A				
Sample no.	Model	OCV at start of test (Vdc)	Maximum Charging Current (2.0 It A)	Maximum Charging Voltage (Vdc)	Total Time of Charging (h)	temperature of the outer casing (°C)	Results
—	—	—	—	—	—	—	—
—	—	—	—	—	—	—	—
—	—	—	—	—	—	—	—
—	—	—	—	—	—	—	—

supplementary information:

- NF: No Fire
- NE: No Explosion
- Fire: the emission of flames from a cell or battery.
- Explosion: failure that occurs when a cell container or battery case opens violently and major components are forcibly expelled.

Remark: Total time of charging ≤0.1h means the PCB protection in a flash.

7.3.9	Forced discharge		N/A
	A discharged cell is subjected to a reverse charge at 1 It A for 90 min		
	Results: No fire. No explosion..... :		N/A

## IEC 62133: 2012

Clause	Requirement – Test	Result – Remark	Verdict		
Sample no.	Model	OCV before application of reverse charge (Vdc)	Measured Reverse Charge It (A)	Total Time for Reversed Charge Application (Min)	Results
—	—	—	—	—	—
—	—	—	—	—	—
—	—	—	—	—	—
—	—	—	—	—	—
—	—	—	—	—	—

supplementary information:

- NF: No Fire
- NE: No Explosion
- Fire: the emission of flames from a cell or battery.
- Explosion: failure that occurs when a cell container or battery case opens violently and major components are forcibly expelled.

Remark: Total time of charging  $\leq 0.1$ h means the PCB protection in a flash.

<b>8</b>	<b>Specific requirements and tests</b>		P
8.1	Charging procedure for test purposes		P
8.1.1	First procedure		-
	Test is carried out at $20^{\circ}\text{C} \pm 5^{\circ}\text{C}$ . Charging method declared by the manufacturer.		P
	Prior to charging, the battery shall have been discharged at $20^{\circ}\text{C} \pm 5^{\circ}\text{C}$ at a constant current of 0,2 It A down to a specified final voltage.		P
8.1.2	Second procedure		-
	For clause 8.3.1, 8.3.2, 8.3.4, 8.3.5, and 8.3.9 charging procedure After stabilization for 1 to 4 hours respectively at ambient temperature of highest test temperature and lowest test temperature, as specified in Table 4		P
	cells are charged by using the upper limited charging voltage and maximum charging current, until the charging current is reduced to 0,05 It A, using a constant voltage charging method.		P
	- Upper limit charging voltage	4.25V	-
	- Maximum charging current Specified by the manufacturer of cells	1800mA	-
	Charging temp. Upper limit	45°C	-
	Charging temp. Lower limit	10°C	-
8.2	Intended use		P



## IEC 62133: 2012

Clause	Requirement – Test	Result – Remark	Verdict			
8.2.1	Continuous charging at constant voltage (cells)		P			
	Fully charged cells are subjected for 7 days to a charge as specified by the manufacturer.		P			
	Results:: No fire, no explosion, no leakage	See below table;	P			
Sample No.	Model	Recommended Charging Method, CC, CV, or CC/CV	Recommended Charging Voltage Vc, Vdc	Recommended Charging Current Irec, mA	OCV at Start of Test, Vdc	Results
C01#	103450	CC/CV	4.20	180	4.17	NF, NE, NL
C02#	103450	CC/CV	4.20	180	4.17	NF, NE, NL
C03#	103450	CC/CV	4.20	180	4.18	NF, NE, NL
C04#	103450	CC/CV	4.20	180	4.18	NF, NE, NL
C05#	103450	CC/CV	4.20	180	4.18	NF, NE, NL
supplementary information:						
<ul style="list-style-type: none"> <li>- NF: No Fire</li> <li>- NE: No Explosion</li> <li>- NL: No Leakage</li> <li>- Fire: the emission of flames from a cell or battery.</li> <li>- Explosion: failure that occurs when a cell container or battery case opens violently and major components are forcibly expelled.</li> <li>- Leakage: visible escape of liquid electrolyte.</li> </ul>						

8.2.2	Moulded case stress at high ambient temperature (battery)		P	
	Fully charged batteries according to the first procedure in 8.1.1, the batteries were placed in an air-circulating oven at a temperature of 70°C ± 2°C for 7 hours. Afterwards, they are removed and allowed to return to room temperature.		P	
	Results: no physical distortion of the battery casing resulting in exposure if internal components.		P	
Sample No.	B01#	B02#	B03#	
Status	No evidence of mechanical damage No physical distortion of the battery case resulting in exposure of internal components.			P
8.3	Reasonably foreseeable misuse		P	
8.3.1	External short circuit (cell)		P	
	Fully charged each cell according to the second procedure in 8.1.2;		P	
	Fully charged cells were subjected to a short circuit test at		P	

## IEC 62133: 2012

Clause	Requirement – Test				Result – Remark		Verdict
	20°C ± 5°C.						
	The external resistance of 80±20 mΩ.						P
	The cells were tested for 24 h or until the case temperature declined by 20% of the maximum temperature rise.						P
	Results: no fire, no explosion.						P
	After the test				See below		P
Sample No.	Ambient temperature (At 20°C ± 5°C)	OCV at start of test (Vdc)	Maximum case temperature rise ΔT, (°C)	Resistance of Circuit (mΩ)	Charging temp. Upper limit (°C)	Results	P
C06	23.5	4.17	76.8	80	45	NF, NE	P
C07	24.3	4.17	81.2	80	45	NF, NE	P
C08	23.6	4.18	79.6	80	45	NF, NE	P
C09	23.7	4.18	83.5	80	45	NF, NE	P
C10	23.9	4.18	85.9	80	45	NF, NE	P
Sample No.	Ambient temperature (At 20°C ± 5°C)	OCV at start of test (Vdc)	Maximum case temperature rise ΔT, (°C)	Resistance of Circuit (mΩ)	Charging temp. Lower limit (°C)	Results	P
C11	23.7	4.15	80.8	80	10	NF, NE	P
C12	23.9	4.15	82.5	80	10	NF, NE	P
C13	24.3	4.15	84.3	80	10	NF, NE	P
C14	24.0	4.15	83.8	80	10	NF, NE	P
C15	24.8	4.14	85.2	80	10	NF, NE	P
supplementary information							
<ul style="list-style-type: none"> <li>- NF: No Fire</li> <li>- NE: No Explosion</li> <li>- Fire: the emission of flames from a cell or battery.</li> <li>- Explosion: failure that occurs when a cell container or battery case opens violently and major components are forcibly expelled.</li> </ul>							

8.3.2	External short circuit (battery)		P
	Fully charged each battery according to the second procedure in 8.1.2;		P
	Fully charged batteries were subjected to a short circuit test at 55°C ± 5°C.		P

## IEC 62133: 2012

Clause	Requirement – Test			Result – Remark			Verdict
	The external resistance of 80±20 mΩ.						P
	The battery pack were tested for 24 h or until the case temperature declined by 20% of the maximum temperature rise.						P
	In case of rapid decline in short circuit current, the battery pack should remain on test for an additional one hour after the current reaches a low end steady state condition. This typically refers to a condition where the per cell voltage (series cells only) of the battery is below 0,8 V and is decreasing by less than 0,1 V in a 30-minute period.						N/A
	Results: no fire, no explosion.						P
	After the test			See below			P
Sample No.	Ambient temperature (At 55°C ± 5°C)	OCV at start of test (Vdc)	Maximum case temperature rise ΔT, (°C)	Resistance of Circuit (mΩ)	Charging temp. Upper limit (°C)	Results	P
B04#	56.3	4.18	0.2	80	45	NF, NE	P
B05#	56.6	4.18	0.1	80	45	NF, NE	P
B06#	56.6	4.17	0.3	80	45	NF, NE	P
B07#	56.9	4.18	0.1	80	45	NF, NE	P
B08#	56.2	4.18	0.1	80	45	NF, NE	P
Sample No.	Ambient temperature (At 55°C ± 5°C)	OCV at start of test (Vdc)	Maximum case temperature rise ΔT, (°C)	Resistance of Circuit (mΩ)	Charging temp. Lower limit (°C)	Results	P
B09#	56.6	4.15	0.2	80	10	NF, NE	P
B10#	56.3	4.15	0.3	80	10	NF, NE	P
B11#	56.2	4.15	0.1	80	10	NF, NE	P
B12#	56.3	4.16	0.2	80	10	NF, NE	P
B13#	56.5	4.15	0.1	80	10	NF, NE	P
supplementary information							
<ul style="list-style-type: none"> <li>- NF: No Fire</li> <li>- NE: No Explosion</li> <li>- Fire: the emission of flames from a cell or battery.</li> <li>- Explosion: failure that occurs when a cell container or battery case opens violently and major components are forcibly expelled.</li> </ul>							
8.3.3	Free fall						P

## IEC 62133: 2012

Clause	Requirement – Test	Result – Remark	Verdict
	Ambient temperature of 20±5°C		P
	Fully charged cells or batteries were dropped 3 times from a height of 1.0 m onto a concrete floor.	Three times	P
	After the test, the cell or battery shall be put on rest for a minimum of one hour and then a visual inspection shall be performed.		
	Results: no fire, no explosion		P
Sample No.	C16#	C17#	C18#
Status	NF, NE	NF, NE	NF, NE
Sample No.	B14#	B15#	B16#
Status	NF, NE	NF, NE	NF, NE
supplementary information:			
<ul style="list-style-type: none"> <li>- NF: No Fire</li> <li>- NE: No Explosion</li> <li>- Fire: the emission of flames from a cell or battery.</li> <li>- Explosion: failure that occurs when a cell container or battery case opens violently and major components are forcibly expelled.</li> </ul>			

8.3.4	Thermal abuse (cells)				P
	Fully charged cells were placed in a gravity or circulating air-convection oven. The oven temperature was raised at a rate of 5°C/min ± 2°C/min to a temperature of 130°C ± 2°C. The cell remained at that temperature for 10 minutes before the test was terminated.				P
	Results: no fire, no explosion				P
After the test (Charging temp. Upper limit 45°C)					
Sample No.	C19#	C20#	C21#	C22#	C23#
Status	NF, NE	NF, NE	NF, NE	NF, NE	NF, NE
After the test (Charging temp. Lower limit -5°C)					
Sample No.	C24#	C25#	C26#	C27#	C28#
Status	NF, NE	NF, NE	NF, NE	NF, NE	NF, NE
supplementary information:					
<ul style="list-style-type: none"> <li>- NF: No Fire</li> <li>- NE: No Explosion</li> <li>- Fire: the emission of flames from a cell or battery.</li> <li>- Explosion: failure that occurs when a cell container or battery case opens violently and major components are forcibly expelled.</li> </ul>					

## IEC 62133: 2012

Clause	Requirement – Test	Result – Remark	Verdict
--------	--------------------	-----------------	---------

8.3.5	Crush (cells)		P
	Each fully charged cell, charged according to the second procedure at the upper limit charging temperature in 8.1.2, is immediately transferred and crushed between two flat surfaces in an ambient temperature.		P
	Fully charged cells were crushed between two flat surfaces with a hydraulic ram exerting a force of 13 kN ± 1 kN.		P
	The crushing is performed in a manner that will cause the most adverse result.	See below	P
	- Once the maximum force has been applied,		P
	- or an abrupt voltage drop of one-third of the original voltage has been obtained,		N/A
	- or 10 % of deformation has occurred compared to the initial dimension, the force is released (whichever condition occurs first should be the indication that the force should be released).		N/A
	A cylindrical or prismatic cell was crushed with its longitudinal axis parallel to the flat surfaces of the crushing apparatus. Test only the wide side of prismatic cells.		P
	Results: no fire, no explosion.		P

After the test (Charging temp. Upper limit 45°C)

Sample No.	C29#	C30#	C31#	C32#	C33#
Status	NF, NE	NF, NE	NF, NE	NF, NE	NF, NE

supplementary information:

- NF: No Fire
- NE: No Explosion
- Fire: the emission of flames from a cell or battery.
- Explosion: failure that occurs when a cell container or battery case opens violently and major components are forcibly expelled.

8.3.6	Over-charging of battery		P
	The test shall be carried out in an ambient temperature of +20 °C±5°C.		P
	Each test battery shall be discharged at a constant current of 0,2 kA, to a final discharge voltage specified by the		P

## IEC 62133: 2012

Clause	Requirement – Test	Result – Remark	Verdict				
	manufacturer.						
	A discharged battery was charged from a power supply of 5.0V per cell or not to exceed the maximum voltage supplied by the recommended charger, at a charging current of 2.0 I A.  Total Time of Charging: The test shall be continued until the temperature of the outer casing reaches steady state conditions (less than 10 °C change in 30-minute period) or returns to ambient.		P				
	Results: no fire, no explosion.		P				
	After the test	No fire, no explosion.	P				
Sample no.	Model	OCV at start of test (Vdc)	Maximum Charging Current (2.0 I A)	Maximum Charging Voltage (Vdc)	Total Time of Charging (h)	temperature of the outer casing (°C)	Results
B17#	ZN-103450	3.32	3.6	5	≤0.1	25.3	NF, NE
B18#	ZN-103450	3.30	3.6	5	≤0.1	25.2	NF, NE
B19#	ZN-103450	3.32	3.6	5	≤0.1	25.3	NF, NE
B20#	ZN-103450	3.33	3.6	5	≤0.1	25.2	NF, NE
B21#	ZN-103450	3.32	3.6	5	≤0.1	25.5	NF, NE
supplementary information: - NF: No Fire - NE: No Explosion - Fire: the emission of flames from a cell or battery. - Explosion: failure that occurs when a cell container or battery case opens violently and major components are forcibly expelled. Remark: Total time of charging ≤0.1h means the PCB protection in a flash.							

8.3.7	Forced discharge (cells)		P		
	A discharged cell is subjected to a reverse charge at 1 I A for 90 min.		P		
	Results: no fire, no explosion		P		
Sample no.	Model	OCV before application of reverse charge (Vdc)	Measured Reverse Charge I t (A)	Total Time for Reversed Charge Application (Min)	Results
C34#	103450	3.15	1.8	90	NF, NE
C35#	103450	3.15	1.8	90	NF, NE
C36#	103450	3.16	1.8	90	NF, NE
C37#	103450	3.15	1.8	90	NF, NE
C38#	103450	3.19	1.8	90	NF, NE
supplementary information:					

## IEC 62133: 2012

Clause	Requirement – Test	Result – Remark	Verdict
--------	--------------------	-----------------	---------

- NF: No Fire  
- NE: No Explosion  
- Fire: the emission of flames from a cell or battery.  
- Explosion: failure that occurs when a cell container or battery case opens violently and major components are forcibly expelled.

8.3.8	Transport test		N/A
	Regulations concerning international transport of lithium ion batteries are based on the UN Recommendations on the Transport of Dangerous Goods. Testing requirements are defined in the UN Manual of Tests & Criteria.		N/A
	Testing laboratory		N/A

8.3.9	Design evaluation – Forced internal short circuit (cells)		N/A
	The cells complied with nation requirement for	Prismatic cells	-
	The pressing was stopped upon: -A voltage drop of 50 mV has been detected; or		N/A
	-The pressing force of 800N (cylindrical cells) or 400N (prismatic cells) has been reached		N/A
	Results: No fire.		N/A

Model	Chamber ambient, (°C)	OCV at start of test, (Vdc)	Particle location 1)	Maximum applied pressure, (N)	Results
C39	--	--	--	--	NE, NF
C40	--	--	--	--	NE, NF
C41	--	--	--	--	NE, NF
C42	--	--	--	--	NE, NF
C43	--	--	--	--	NE, NF
C44	--	--	--	--	NE, NF
C45	--	--	--	--	NE, NF
C46	--	--	--	--	NE, NF
C47	--	--	--	--	NE, NF
C48	--	--	--	--	NE, NF

supplementary information:

<sup>1)</sup>Identify one of the following;

1:Nickel particle inserted between positive and negative (active material) coated area.

2:Nickel particle inserted between positive aluminium foil and negative active material coated area.

- No Fire or Explosion

- No Leakage

## IEC 62133: 2012

Clause	Requirement – Test	Result – Remark	Verdict
--------	--------------------	-----------------	---------

- Leakage
- Fire
- Explosion
- Bulge
- Other (Please Explain)

<b>9</b>	<b>Information for safety</b>		P
	Information is provided to equipment manufacturers in the form of instructions to minimize and mitigate hazards associated with the cells or batteries in accordance with guidelines outlined in informative Annex B.		P
	Information is provided to end-users in the form of instructions to minimize and mitigate hazards associated with the batteries in accordance with guidelines outlined in informative Annex C.		P

<b>10</b>	<b>Marking</b>		P
10.1	Cell marking		P
	Rechargeable Li or Li-ion		N/A
	Battery designation		N/A
	Polarity of terminal		N/A
	Date of manufacture		P
	Name or identification of the manufacturer or supplier		P
	Nominal voltage(V)	3.7V	P
	Rated Capacity (mAh)	1800mAh	P
10.2	Battery marking	See below	P
	Rechargeable Li or Li-ion	Li-ion	N/A
	Battery designation		N/A
	Polarity of terminal	On the battery	N/A
	Date of manufacture	On the battery	N/A
	Name or identification of the manufacturer or supplier		P
	Nominal voltage(V)	3.7V	P
	Rated Capacity (mAh)	1800mAh	P
	Caution statement	For details please see the picture	P



## IEC 62133: 2012

Clause	Requirement – Test	Result – Remark	Verdict
10.3	Other information		P
	Disposal instructions are marked on the battery or supplied in the information packaged with the battery.	See Specification book	P
	Recommended charging instruction are marked on the battery or supplied in the information packaged with the battery.	See Specification book	P

<b>11</b>	<b>Packaging</b>		P
	Cells or batteries were provided with packaging that was adequate to avoid mechanical damage during transport, handling and stacking. The materials and pack design was chosen to prevent the development of unintentional electrical conduction, corrosion of the terminal and ingress of moisture.		P

<b>Annex A</b>	<b>Charging range of secondary lithium ion cells for safe use</b>		<b>P</b>
A.1	General		P
A.2	Safety of lithium-ion secondary battery	Complied	P
A.3	Consideration on charging voltage	Complied	P
A.3.1	General		P
A.3.2	Upper limit charging voltage	4.2V	P
A.3.2.1	General		P
A.3.2.2	Explanation of safety viewpoint		P
A.3.2.3	Safety requirements, when different upper limit charging voltage is applied	4.2V	P
A.4	Consideration of temperature and charging current		P
A.4.1	General		P
A.4.2	Recommended temperature range	See A.4.2.2.	P
A.4.2.1	General		P
A.4.2.2	Safety consideration when a different recommended temperature range is applied	Charging temperature for cell declared by client is: 0-45°C	P
A.4.3	High temperature range	Not higher than the temperature range specific in this standard.	N/A
A.4.3.1	General		N/A
A.4.3.2	Explanation of safety viewpoint		N/A
A.4.3.3	Safety considerations when specifying charging conditions in high temperature range		N/A
A.4.3.4	Safety consideration when specifying new upper limit in high temperature range		N/A
A.4.4	Low temperature range	Charging low temperature declared by client is: 0°C	P
A.4.4.1	General		P

## IEC 62133: 2012

Clause	Requirement – Test	Result – Remark	Verdict
A.4.4.2	Explanation of safety viewpoint		P
A.4.4.3	Safety considerations, when specifying charging conditions in low temperature range		P
A.4.4.4	Safety considerations when specifying a new lower limit in the low temperature range	-5°C	P
A.4.5	Scope of the application of charging current		P
A.5	Sample preparation		P
A.5.1	General		P
A.5.2	Insertion procedure for nickel particle to generate internal short		P
	The insertion procedure carried out at 20°C±5°C and under -25 °C of dew point		P
A.5.3	Disassembly of charged cell		P
A.5.4	Shape of nickel particle	H:0.2mm T:0.1mm L shape(Angle:90±10°): 1.0mm	P
A.5.5	Insertion of nickel particle to cylindrical cell		N/A
A.5.5.1	Insertion of nickel particle to winding core		N/A
A.5.5.2	Mark the position of nickel particle on the both end of winding core of the separator		N/A
A.5.6	Insertion of nickel particle to prismatic cell		N/A

## Photo Documentation



Photo 1

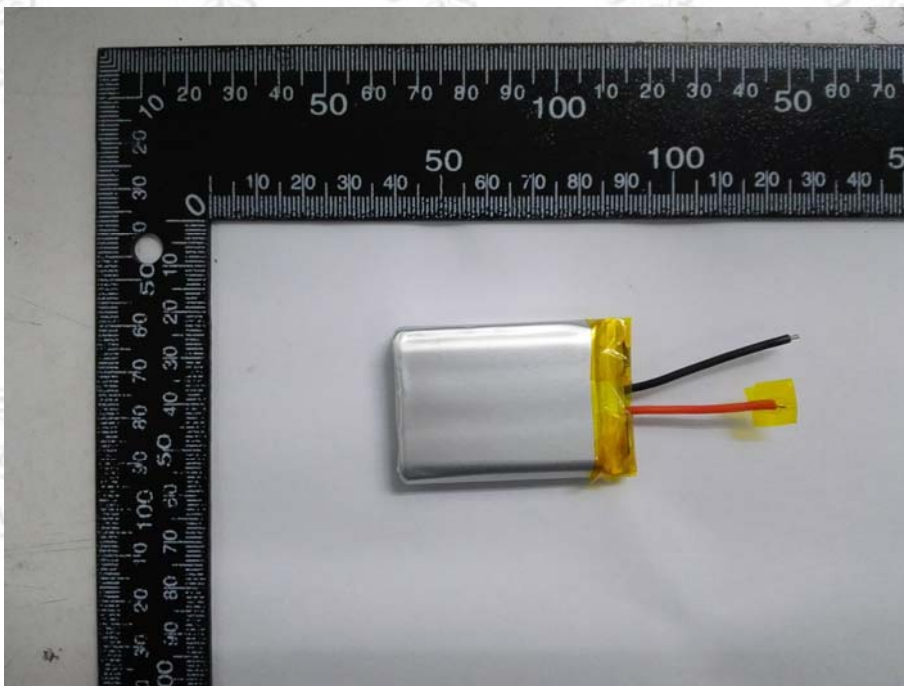

Photo 2

## Photo Documentation

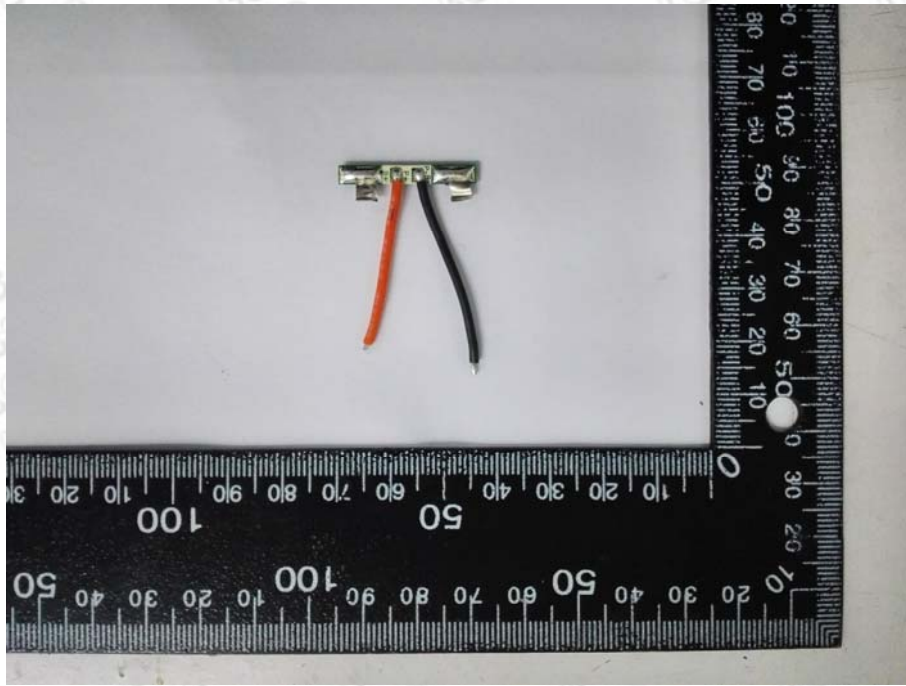

Photo 3

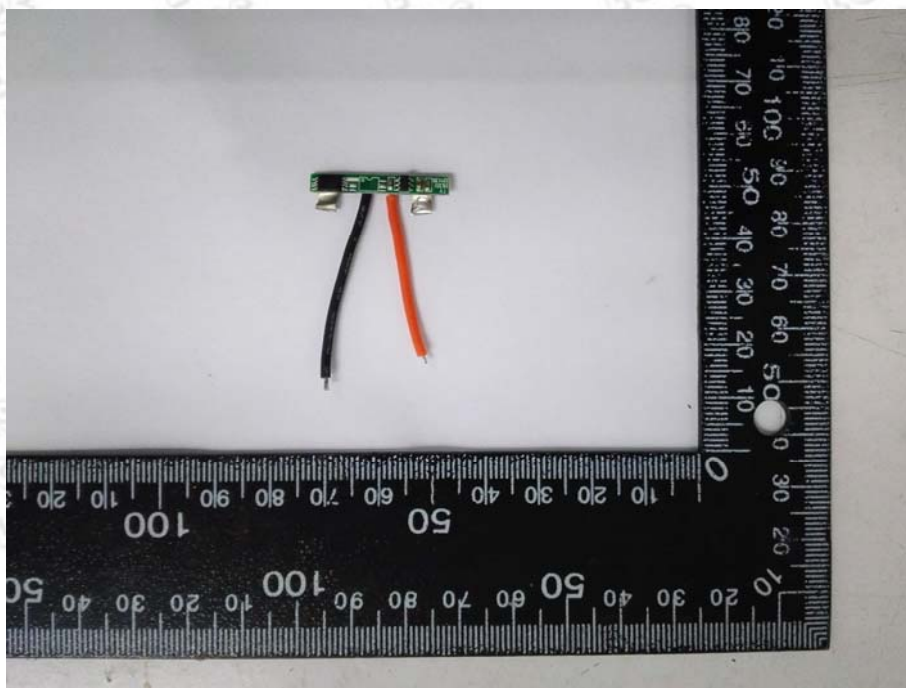

Photo 4

## Photo Documentation

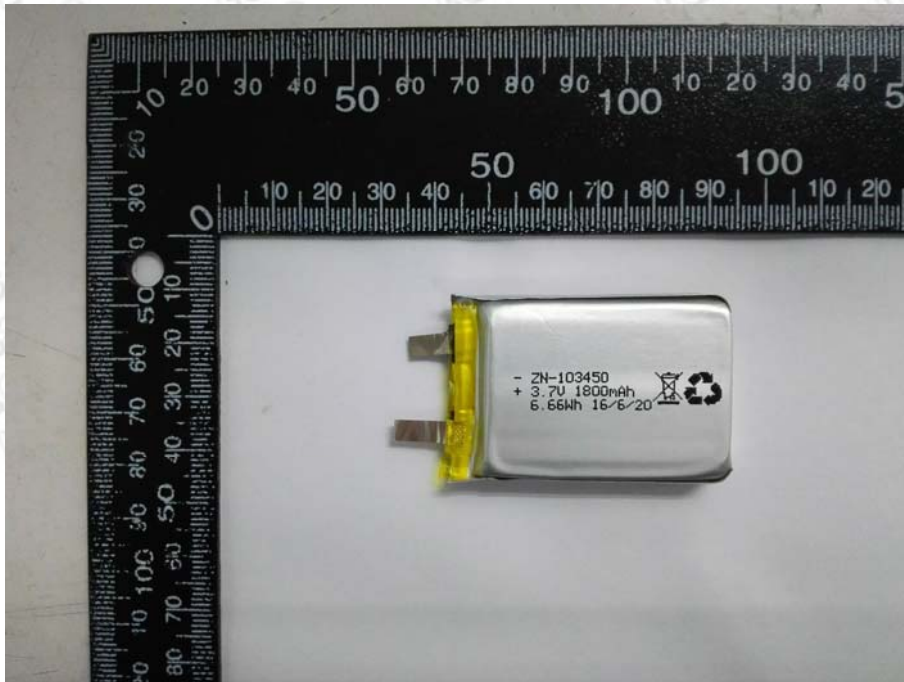

Photo 5



Photo 6