

Japan Radio Test Report

Project No. : 1504C213A
Equipment : PHOTON
Model Name : PHOTONH, PHOTONNOH
Applicant : Particle Industries, Inc.
Address : 1400 Tennessee St, #4 San Francisco, CA 94107

Date of Receipt : Oct. 30, 2015
Date of Test : Oct. 30, 2015 ~ Jan. 04, 2016
Issued Date : Jan. 05, 2016
Tested by : BTL Inc.

Testing Engineer : Shawn Xiao
(Shawn Xiao)

Technical Manager : David Mao
(David Mao)

Authorized Signatory : Steven Lu
(Steven Lu)

B T L I N C .

No.3, Jinshagang 1st Road, Shixia, Dalang Town, Dongguan,
Guangdong, China.

TEL: +86-769-8318-3000 FAX: +86-769-8319-6000

Declaration

BTL represents to the client that testing is done in accordance with standard procedures as applicable and that test instruments used has been calibrated with the standards traceable to National Measurement Laboratory (**NIM**) of **China**., or National Institute of Standards and Technology (**NIST**) of **U.S.A.**

BTL's reports apply only to the specific samples tested under conditions. It is manufacture's responsibility to ensure that additional production units of this model are manufactured with the identical electrical and mechanical components. **BTL** shall have no liability for any declarations, inferences or generalizations drawn by the client or others from **BTL** issued reports.

BTL's report must not be used by the client to claim product certification, approval, or endorsement by NVLAP, NIST, or any agency of the Federal Government.

This report is the confidential property of the client. As a mutual protection to the clients, the public and **BTL-self**, extracts from the test report shall not be reproduced except in full with **BTL's** authorized written approval.

BTL's laboratory quality assurance procedures are in compliance with the **ISO Guide 17025** requirements, and accredited by the conformity assessment authorities listed in this test report.

Limitation

For the use of the authority's logo is limited unless the Test Standard(s)/Scope(s)/Item(s) mentioned in this test report is (are) included in the conformity assessment authorities acceptance respective.

Table of Contents

	page
1 . CERTIFICATION	5
2. SUMMARY OF TEST RESULTS	6
2.1 TEST FACILITY	7
2.2 MEASUREMENT UNCERTAINTY	7
3. GENERAL INFORMATION	8
3.1 GENERAL DESCRIPTION OF EUT	8
3.2 DESCRIPTION OF TEST MODES	9
3.3 BLOCK DIAGRAM SHOWING THE CONFIGURATION OF SYSTEM TESTED	11
3.4 DESCRIPTION OF SUPPORT UNITS	11
3.5 TABLE FOR PARAMETERS OF TEST SOFTWARE SETTING	12
4. TEST RESULTS	13
4.1 FREQUENCY TOLERANCE MEASUREMENT	13
4.2 OCCUPIED BANDWIDTH AND SPREAD-SPECTRUM BANDWIDTH MEASUREMENT	14
4.3 UNWANTED EMISSION INTENSITY MEASUREMENT	16
4.4 ANTENNA POWER ERROR MEASUREMENT	18
4.5 LIMITATION OF COLLATERAL EMISSION OF RECEIVER MEASUREMENT	20
4.6 TRANSMISSION ANTENNA GAIN (EIRP ANTENNA POWER) MEASUREMENT	22
4.7 TRANSMISSION RADIATION ANGLE WIDTH (3DB BEAMWIDTH) MEASUREMENT	26
4.8 RADIO INTERFERENCE PREVENTION CAPABILITY MEASUREMENT	28
4.9 CARRIER SENSE CAPABILITY MEASUREMENT	30
4.10 CONSTRUCTION PROTECTION CONFIRMATION METHOD	32
5. LIST OF MEASURING EQUIPMENTS	33
6. EUT TEST PHOTO	34
ATTACHMENT A - FREQUENCY TOLERANCE	35
ATTACHMENT B - OCCUPIED BANDWIDTH AND SPREAD-SPECTRUM BANDWIDTH	72
ATTACHMENT C - UNWANTED EMISSION INTENSITY	133
ATTACHMENT D - ANTENNA POWER ERROR	284
ATTACHMENT E - LIMITATION OF COLLATERAL EMISSION OF RECEIVER	291

REPORT ISSUED HISTORY

Issued No.	Description	Issued Date
BTL-JPAP-1-1504C213A	Original Issue.	Jan. 05, 2016

1. CERTIFICATION

Equipment : PHOTON
Trade Name : PHOTON
Model Name : PHOTONH, PHOTONNOH
Applicant : Particle Industries, Inc.
Manufacturer : Particle Industries, Inc.
Address : 1400 Tennessee St, #4 San Francisco, CA 94107
Factory : ABO Electronics (Shenzhen) Co., Ltd
Address : Block B3, Haocheng Industrial Park, Hexiu West Rd, Heping Village, Fuyong, Baoan, Shenzhen, Guangdong, 518103, China
Date of Test : Oct. 30, 2015 ~ Jan. 04, 2016
Test Sample : Engineering Sample
Technical : Article 49-20 and the relevant articles of the Ordinance Regulating Radio
Standard(s) : Equipment
Test Procedure : MIC Notice No.88 Appendix No.43 Test method

The above equipment has been tested and found compliance with the requirement of the relative standards by BTL Inc.

The test data, data evaluation, and equipment configuration contained in our test report (Ref No. BTL-JPAP-1-1504C213A) were obtained utilizing the test procedures, test instruments, test sites that has been accredited by the Authority of CNAS according to the ISO-17025 quality assessment standard and technical standard(s).

2. SUMMARY OF TEST RESULTS

Section Number	Description of Test	Article of ORRE ⁽¹⁾	Result
4.1	Frequency Error/ Frequency Tolerance	Article 5, Table 1	Pass
4.2	Occupied Bandwidth (99%) and Spread-spectrum Bandwidth (90%) / Spreading Factor (diffusion rate)	Article 6, Table 2 & Article 49-20, Item1-h & 1-i	Pass
4.3	Unwanted Emission Intensity	Article 7, Table 3	Pass
4.4	Antenna Power Error/Tolerance	Article 14	Pass
4.5	Limitation of Collateral Emission of Receiver	Article 24, Paragraph 2	Pass
4.6	Transmission Antenna Gain (EIRP Antenna Power) - Dipole antenna	Article 49-20, Item 1-e & 1-f	Pass
4.7	Transmission Radiation Angle Width (3dB Beamwidth) - Dipole antenna	Article 49-20, Item 1-f	Pass
4.8	Radio Interference Prevention Capability	Article 9-4, Item 9-C Article 6-2, Item 3 of the Regulation for Enforcement of the Radio Law	Pass
4.9	Carrier Sense Capability	Article 49-20, Item1-k	Good
4.10	Construction Protection Confirmation	Article 49-20, Item1-a	Pass

Method of measurement:	MIC Notice No.88 Appendix No.43
Test condition:	Conductive, RF test program provided by the customer was used to control the operating channel as well as the output power level.

Abbreviations used in this test report are as follows;

NC:	Normal Condition
EC:	Extreme Condition
EUT:	Equipment Under Test
DS:	Direct spreading
FH:	Frequency hopping
OFDM:	Orthogonal frequency division multiplexing

2.1 TEST FACILITY

The test facilities used to collect the test data in this report is **DG-CB02/OVEN** at the location of No.3,Jinshagang 1st Road, Shixia, Dalang Town, Dongguan, Guangdong, China.

2.2 MEASUREMENT UNCERTAINTY

Test Items	Uncertainty	Remark
Frequency Error / 99% & 90% Bandwidth	$\pm 6.25 \times 10^{-7}$	Confidence levels of 95%
Antenna Power / TX-RX Emission	$\pm 0.5\text{dB}$	Confidence levels of 95%
Transmission Antenna Gain	$\pm 3.72\text{dB}$	Confidence levels of 95%
Carrier Sense Capability	$\pm 0.76\text{dB}$	Confidence levels of 95%

3. GENERAL INFORMATION

3.1 GENERAL DESCRIPTION OF EUT

Equipment	PHOTON	
Trade Name	PHOTON	
Model Name	PHOTONH, PHOTONNOH	
Model Difference	PHOTONH has male header, PHOTONNOH doesn't have male header	
Product Description	Operation Frequency	2412-2472MHz
	Modulation Technology	802.11b:DSSS 802.11g:OFDM 802.11n:OFDM
	Bit Rate of Transmitter	802.11b: 11/5.5/2/1 Mbps 802.11g: 54/48/36/24/18/12/9/6 Mbps 802.11n up to 65 Mbps
	Occupied Bandwidth - Chip antenna	24.10 MHz
	Occupied Bandwidth -Dipole antenna	17.70 MHz
	Spread Bandwidth - Chip antenna	7.50 MHz
	Spread Bandwidth -Dipole antenna	8.40 MHz
	Software Version	V019
	Hardware Version	RC4
	Antenna Power (Rated Power) - Chip antenna	6.30 mW/MHz 11b mode 4.00 mW/MHz 11g mode 2.50 mW/MHz 11n(HT20) mode
	Antenna Power (Rated Power) - Dipole antenna	8.20 mW/MHz 11b mode 2.58 mW/MHz 11g mode 1.50 mW/MHz 11n(HT20) mode
	Antenna Power (Max. Conducted Power) - Chip antenna	6.75744 mW/MHz 11b mode 4.38311 mW/MHz 11g mode 2.39211 mW/MHz 11n(HT20) mode
	Antenna Power (Max. Conducted Power) -Dipole antenna	9.37091 mW/MHz 11b mode 2.85616 mW/MHz 11g mode 1.54093 mW/MHz 11n(HT20) mode
	Power Source	Supplied from PC USB port.
Power Rating	DC 5V	

Note:

1. For a more detailed features description, please refer to the manufacturer's specifications or the user's manual.
2. Channel List:

CH01 – CH13 for 802.11b, 802.11g, 802.11n(20MHz)					
Channel	Frequency (MHz)	Channel	Frequency (MHz)	Channel	Frequency (MHz)
01	2412	06	2437	11	2462
02	2417	07	2442	12	2467
03	2422	08	2447	13	2472
04	2427	09	2452		
05	2432	10	2457		

3. Table for Filed Antenna:

Ant.	Brand	Model Name	Antenna Type	Connector	Gain (dBi)	Note
1	ACX	AT7020 -E3R0HBA	Chip	N/A	1.30	TX/RX
2	CRMXTM	104-1001	Dipole	RP-TNC	2.15	TX/RX

Note: EUT has two types of antenna, one with chip antenna, another one with dipole antenna.

3.2 DESCRIPTION OF TEST MODES

The EUT was tested while in a continuous transmitter / receiver mode

The EUT was tuned to a low, middle and high channel for all tests. The EUT continuously transmitted a modulated packet with payload, while transmitting the EUT was setup to operate at the intended maximum power output available to the end user. For all test case pre/scans were completed in all modes to determine worst case levels

Pretest Test Mode	Description
Mode 1	802.11b/CH01,CH07,CH13
Mode 2	802.11g/CH01,CH07,CH13
Mode 3	802.11n(HT20)/CH01,CH07,CH13

For Conducted	
Final Test Mode	Description
Mode 1	802.11b/CH01,CH07,CH13
Mode 2	802.11g/CH01,CH07,CH13
Mode 3	802.11n(HT20)/CH01,CH07,CH13

Power Supply Voltage Fluctuation Test

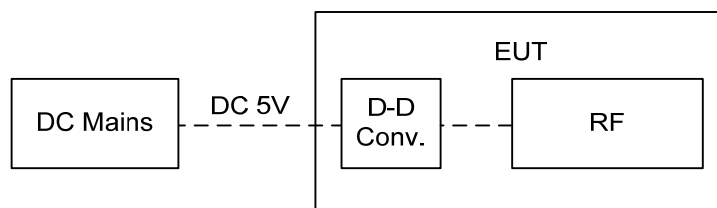

Voltage Fluctuation Test	Normal Voltage	High Voltage + 10% of Normal Voltage	Low Voltage - 10% of Normal Voltage
DC Power	5V	5.5V	4.5V
Voltage Variation (%)	-	+ 10%	- 10%

Note:

Voltage Variation (%)

$$= (\text{Output Low or Low Voltage} - \text{Output Normal Voltage}) / \text{Output Normal Voltage} * 100$$

During the input supply voltage to the EUT from the external power source is varied by +/- 10%, if output voltage had been confirmed that the fluctuation of power supply to the RF circuit of EUT (excluding power source) is equal to or less than +/- 1%. Exempt extremely high and low supply voltage condition tests, EUT only operated in normal voltage to test all regulations.

3.3 BLOCK DIAGRAM SHOWING THE CONFIGURATION OF SYSTEM TESTED

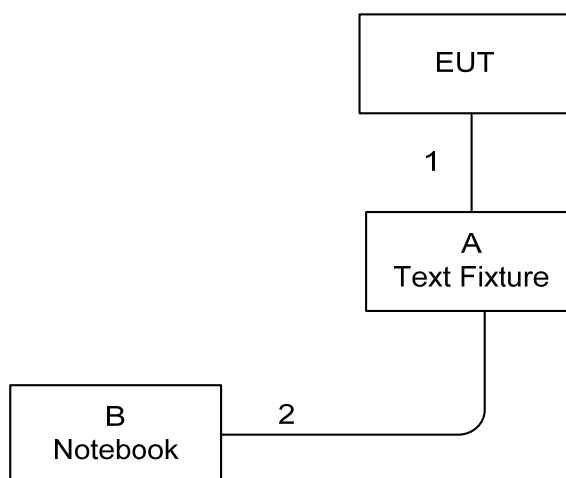

3.4 DESCRIPTION OF SUPPORT UNITS

The EUT has been tested as an independent unit together with other necessary accessories or support units. The following support units or accessories were used to form a representative test configuration during the tests.

Item	Equipment	Mfr/Brand	Model/Type No.	FCC ID	Series No.
A	Fixture	N/A	N/A	N/A	N/A
B	Notebook	DELL	INSPIRON 1420	DOC	JX193A01SDC2

Item	Shielded Type	Ferrite Core	Length	Note
1	NO	NO	0.5m	Fixture Cable
2	NO	NO	0.5m	USB Cable

3.5 TABLE FOR PARAMETERS OF TEST SOFTWARE SETTING

During testing, Channel & Power Controlling Software provided by the customer was used to control the operating channel as well as the output power level. The RF output power selection is for the setting of RF output power expected by the customer and is going to be fixed on the firmware of the final end product.

For Chip antenna

Test Software Version	N/A		
Frequency (MHz)	2412	2442	2472
IEEE 802.11b DSSS	20	20	20
IEEE 802.11g OFDM	8	20	8
IEEE 802.11n(HT20) OFDM	8	20	8

For Dipole antenna

Test Software Version	N/A		
Frequency (MHz)	2412	2442	2472
IEEE 802.11b DSSS	20	20	20
IEEE 802.11g OFDM	16	20	5
IEEE 802.11n(HT20) OFDM	7	20	5

4. TEST RESULTS

4.1 FREQUENCY TOLERANCE MEASUREMENT

4.1.1 LIMIT

Item	Limits (See Article 5, Table1 of the Ordinance Regulating Radio Equipment)
Frequency Tolerance	$\leq 50\text{ppm}$

4.1.2 MEASURING INSTRUMENTS AND SETTING

Please refer to section 5 in this report. The following table is the setting of the spectrum.

Spectrum Parameter	Setting
Span	200 kHz
RBW / VBW	10 kHz / 10 kHz

4.1.3 TEST PROCEDURES

Test method which surpass to Claus 3 of Annex No.43 of MIC Notification No.88.

1. Frequency accuracy of SA shall be less than 10% of limits tolerance (5ppm)
2. Setting of SA is following as: RBW:10 kHz / VBW:10 kHz / SPAN: 200 KHz / AT: 30dB / Ref: 20dBm
3. Center Frequency: The center frequency of testing for EUT
4. Sweep time: Auto
5. Sweep mode: Continuous sweep
6. Detect mode: Positive peak
7. Mark function: Frequency Counter (Resolution 100Hz)
8. EUT have transmitted absence of modulation signal and fixed channelize. f is using the mark cursor to mark the peak frequency value, f_c is declaring of channel frequency. Then the frequency error formula is $(f_c - f) / f_c \times 10^6$ ppm and the limit is less than $\pm 50\text{ppm}$

4.1.4 TEST SETUP LAYOUT

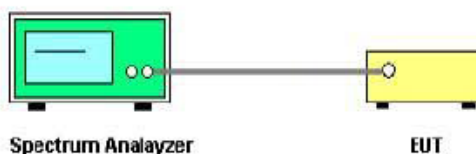

4.1.5 TEST DEVIATION

There is no deviation with the original standard.

4.1.6 EUT OPERATION DURING TEST

The EUT was placed on the test table and programmed in un-modulation function.

Temperature: 20°C Relative Humidity: 58% Test Pressure: 1010 hPa

4.1.7 RESULTS OF FREQUENCY ERROR

Please refer to the Attachment A.

4.2 OCCUPIED BANDWIDTH AND SPREAD-SPECTRUM BANDWIDTH MEASUREMENT

4.2.1 LIMIT

Item	Limits (See Article 6, Table2 and Article 49-20, Item1-h,i of the Ordinance Regulating Radio Equipment)
Occupied Bandwidth	FHSS \leq 83.5MHz; OFDM,DSSS \leq 26MHz; Others \leq 26MHz HT40 \leq 38 MHz
Spreading Bandwidth	\geq 500 kHz (FHSS, DSSS)
Spreading Factor	\geq 5 , Operating Frequency 2400 -2483.5 MHz
	\geq 10 , Operating Frequency 2471 -2497 MHz

4.2.2 MEASURING INSTRUMENTS AND SETTING

Please refer to section 5 in this report. The following table is the setting of the spectrum.

Power Meter Parameter	Setting
Span	50 MHz
RBW / VBW	300 kHz

4.2.3 TEST PROCEDURES

Test method which surpass to Clause 4 of Annex No.43 of MIC Notification No.88.

1. Setting of SA is following as: RBW:300kHz / VBW:300kHz / SPAN: 50MHz / AT: 30dB Ref: 20dBm / Sweep time: Auto / Sweep Mode: Continuous sweep / Detect mode: Positive peak / Trace mode: Max hold
2. EUT have transmitted the maximum modulation signal and fixed channelize (For DSSS or OFDM Device) or continuous maximum power of hopping mode(For FHSS Device). SA set to 99% of occupied bandwidth to measure occupied bandwidth. The limit is less than 26MHz(For DSSS or OFDM Device) or 83.5MHz(For FHSS Device).
3. SA set to 90% of occupied bandwidth to measure Spread Spectrum Bandwidth and must greater than 500kHz.
4. Spread Spectrum Factor = Spread Spectrum Bandwidth / modulation rate of EUT.
5. Spread Spectrum Factor limit is greater than 5

4.2.4 TEST SETUP LAYOUT

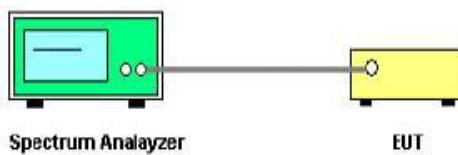

4.2.5 TEST DEVIATION

There is no deviation with the original standard.

4.2.6 EUT OPERATION DURING TEST

The EUT was programmed to be in continuously transmitting mode.

Temperature: 20°C Relative Humidity: 57% Test Pressure: 1010 hPa

4.2.7 RESULTS OF OCCUPIED BANDWIDTH AND SPREAD-SPECTRUM BANDWIDTH

Please refer to the Attachment B.

4.3 UNWANTED EMISSION INTENSITY MEASUREMENT

4.3.1 LIMIT

Item	Limits (See Article 7, Table 3 of the Ordinance Regulating Radio Equipment)
TX	$\leq 2.5 \mu\text{W}/\text{MHz}$ ($30\text{MHz} \leq f \leq 1000\text{MHz}$)
Spurious	$\leq 2.5 \mu\text{W}/\text{MHz}$ ($1000\text{MHz} \leq f < 2387\text{MHz}$; $2496.5\text{MHz} < f$)
Emission	$\leq 25 \mu\text{W}/\text{MHz}$ ($2387\text{MHz} \leq f < 2400\text{MHz}$) and ($2483.5\text{MHz} < f \leq 2496.5\text{MHz}$)
Measurement range: 30MHz - 5th harmonics	

4.3.2 MEASURING INSTRUMENTS AND SETTING

Please refer to section 5 in this report. The following table is the setting of Spectrum Analyzer.

Spectrum Parameter	Setting
Attenuation	Auto
RBW / VBW	1 MHz
Detector	Peak
Trace	Max Hold
Sweep Time	Auto

4.3.3 TEST PROCEDURES

Test method which surpass to Clause 5 of Annex No.43 of MIC Notification No.88.

1. EUT have transmitted the maximum modulation signal and fixed channelize.
2. Setting of SA is following as: RBW/VBW:1 MHz /
AT: 10dB / Ref: 0dBm / Sweep time: Auto / Sweep Mode: Continuous sweep /
Detect mode: Positive peak / Trace mode: Max hold
3. Setting of SA is following as 30MHz and stop frequency 1000MHz Then to mark peak reading value + cable loss shall be less than $2.5\mu\text{W}$.
4. Setting of SA is following as 1000MHz and stop frequency 2387MHz Then to mark peak reading value + cable loss shall be less than $2.5\mu\text{W}$.
5. SA adjusted to start frequency 2387MHz and stop frequency 2400MHz. Then to mark peak reading value + cable loss shall be less than $25\mu\text{W}$.
6. SA adjusted to start frequency 2483.5MHz and stop frequency 2496.5MHz Then to mark peak reading value + cable loss shall be less than $25\mu\text{W}$
7. SA adjusted to start frequency 2496.5MHz and stop frequency 12500MHz Then to mark peak reading value + cable loss shall be less than $2.5\mu\text{W}$

4.3.4 TEST SETUP LAYOUT

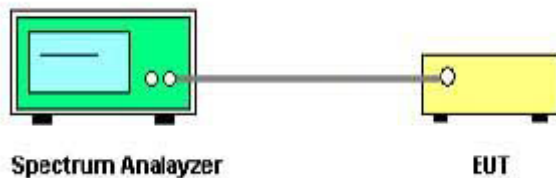

4.3.5 TEST DEVIATION

There is no deviation with the original standard.

4.3.6 EUT OPERATION DURING TEST

The EUT was programmed to be in continuously transmitting mode.

Temperature: 20°C Relative Humidity: 55% Test Pressure: 1010 hPa

Note:

- ※ 1: Frequency Band 1 ($30 \text{ MHz} \leq f \leq 1000 \text{ MHz}$)
- ※ 2: Frequency Band 2 ($1000 \text{ MHz} < f \leq 2387 \text{ MHz}$)
- ※ 3: Frequency Band 3 ($2387 \text{ MHz} \leq f < 2400 \text{ MHz}$)
- ※ 4: Frequency Band 4 ($2483.5 \text{ MHz} \leq f < 2496.5 \text{ MHz}$)
- ※ 5: Frequency Band 5 ($2496.5 \text{ MHz} \leq f < 12.5 \text{ GHz}$)

4.3.7 TEST RESULT OF UNWANTED EMISSION INTENSITY

Please refer to the Attachment C.

4.4 ANTENNA POWER ERROR MEASUREMENT

4.4.1 LIMIT

Item	Limits (See Article 14 and 49-20 Item1-e of the Ordinance Regulating Radio Equipment)
Antenna Power Density	$\leq 3\text{mW/MHz}$ (FHSS 2427 - 2470.75 MHz) $\leq 5\text{mW/MHz}$ (OFDM,DSSS 2400~2483.5MHz) (HT40) $\leq 10\text{mW/MHz}$ (OFDM,DSSS 2400~2483.5MHz) (HT20) $\leq 10\text{mW}$ (Other modulation method 2400~2483.5MHz)
Antenna Power Error	+20%, -80% (Base on manufacturer declare antenna power density)

4.4.2 MEASURING INSTRUMENTS AND SETTING

Please refer to section 5 in this report. The following table is the setting of the power meter and spectrum analyzer.

Spectrum Analyzer	Setting
Attenuation	30dB
Span	0 MHz
RBW	1 MHz
VBW	1 MHz
Detector	Positive Peak
Trace	Max Hold
Sweep Time	Auto

4.4.3 TEST PROCEDURES

Test method which surpass to Clause 6 of Annex No.43 of MIC Notification No.88.

Step 1:

Connect the UUT to the spectrum analyser and use the following settings:

- Centre Frequency: The centre frequency of the channel under test.
- Resolution BW: 1 MHz.
- Video BW: 1 MHz.
- Span: Wide enough to cover the complete power envelope of the signal of the UUT.
- Detector: Peak.
- Trace Mode: Max Hold.

Step 2:

When the trace is complete, find the peak value of the power envelope and record the frequency.

Step 3:

Make the following changes to the settings of the spectrum analyser:

- Centre Frequency: Equal to the frequency recorded in step 2.
- Span: 3 MHz.
- Resolution BW: 1 MHz.
- Video BW: 1 MHz.
- Sweep time: 1 minute.
- Detector: Average (see note).
- Trace Mode: Max Hold.

NOTE: The detector mode "Average" is often referred to as "RMS Average" or "Sample" but do not use Video Average.

Step 4:

When the trace is complete, capture the trace, for example using the "View" option on the spectrum analyser.

Find the peak value of the trace and place the analyser marker on this peak. This level is recorded as the highest mean power (spectral power density) D in a 1 MHz band.

Step 5:

The maximum e.i.r.p. spectral density is calculated from the above measured power density (D), the observed duty

cycle x (see clause 5.7.2.2, step 1), and the applicable antenna assembly gain "G" in dBi, according to the formula below. If more than one antenna assembly is intended for this power setting, the gain of the antenna assembly with the highest gain shall be used.

- $PD = D + G + 10 \log (1/x);$

4.4.4 TEST SETUP LAYOUT

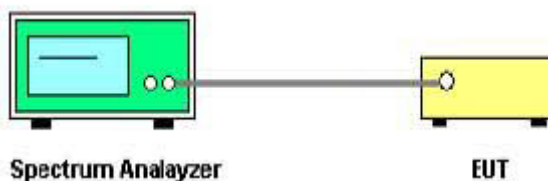

4.4.5 EST DEVIATION

There is no deviation with the original standard.

4.4.6 EUT OPERATION DURING TEST

The EUT was programmed to be in continuously transmitting mode.

Temperature: 20°C Relative Humidity: 55% Test Pressure: 1010 hPa

4.4.7 TEST RESULT OF ANTENNA POWER ERROR

Please refer to the Attachment D.

4.5 LIMITATION OF COLLATERAL EMISSION OF RECEIVER MEASUREMENT

4.5.1 LIMIT

Item	Limits (See Article 24, Paragraph 2 of the Ordinance Regulating Radio Equipment)
RX Spurious Emission:	≤ 4 nW (-54 dBm) ($f < 1$ GHz)
	≤ 20 nW (-47 dBm) (1 GHz $\leq f$)
Measurement range: 30MHz - 5th harmonics	

4.5.2 MEASURING INSTRUMENTS AND SETTING

Please refer to section 5 in this report. The following table is the setting of Spectrum Analyzer.

Spectrum Parameter	Setting
Attenuation	Auto
RBW	1 MHz
VBW	1 MHz
Detector	Peak
Trace	Max Hold
Sweep Time	Auto

4.5.3 TEST PROCEDURES

Test method which surpass to Clause 7 of Annex No.43 of MIC Notification No.88.

1. EUT have the continuous reception mode and fixed only one channelize.
2. Setting of SA is following as RBW / VBW: 1 MHz
AT: 10dB / Ref: 0dBm / Sweep time: Auto / Sweep Mode: Continuous sweep / Detect mode: Positive peak / Trace mode: Max hold
3. SA set RBW: 1 MHz and VBW: 1 MHz. Then adjust to start frequency 30MHz and stop frequency 1000MHz. Search to mark peak reading value + cable loss shall be less than 4nW
4. SA set RBW: 1MHz and VBW: 1MHz. Then adjust to start frequency 1000MHz and stop frequency 12500MHz. Search to mark peak reading value + cable loss shall be less than 20nW
5. If power level of lower emissions are more than 1/10 of limit (.0.4nW for $f < 1$ GHz, 2nW for $f \geq 1$ GHz), all those are to be indicated in the 2nd and 3rd lines. If others are 1/10 or less more of the limit, no necessary to be indicated.

4.5.4 TEST SETUP LAYOUT

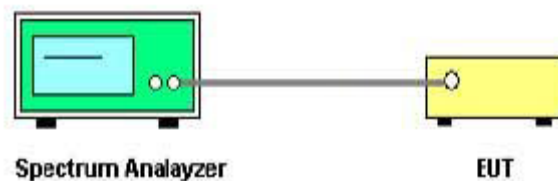

4.5.6 TEST DEVIATION

There is no deviation with the original standard.

4.5.6 EUT OPERATION DURING TEST

The EUT was programmed to be in continuously reception mode.

Temperature: 20°C Relative Humidity: 55% Test Pressure: 1010 hPa

Note:

※6: Frequency Band 6 (30 MHz ≤ f < 1000 MHz)

※7: Frequency Band 7 (1000 MHz ≤ f < 12.5 GHz)

Note: the results in the table contain the cable loss of 0.5dB.

4.5.7 TEST RESULT OF LIMITATION OF COLLATERAL EMISSION OF RECEIVER

Please refer to the Attachment E.

4.6 TRANSMISSION ANTENNA GAIN (EIRP ANTENNA POWER) MEASUREMENT

4.6.1 LIMIT

Item	Limits (See Article 49-20, Item1-f of the Ordinance Regulating Radio Equipment)
EIRP Power Density	$\leq 16.91\text{dBm/MHz}$ (FHSS 2427 - 2470.75 MHz) $\leq 22.14\text{dBm/MHz}$ (OFDM, DSSS 2400~2483.5MHz) $\leq 22.14\text{dBm}$ (Other modulation method 2400~2483.5MHz)
Note: This test item will not be applied to the transmission antenna which has a gain of 2.14dBi or less	

4.6.2 MEASURING INSTRUMENTS AND SETTING

Please refer to section 5 in this report. The following table is the setting of spectrum analyzer.

Spectrum Parameter	Setting
Attenuation	Auto
RBW / VBW	1 MHz
Span	0 MHz
Detector	Peak
Trace	Max Hold

4.6.3 TEST PROCEDURES

Test method which surpass to Clause 10 of Annex No.43 of MIC Notification No.88.

1. Set EUT and measuring antenna at the same height and roughly facing each other.
2. Move the measuring antenna height up and down within ± 50 cm of EUT height and swing it to find the maximum output of the measuring antenna. The output level at the spectrum analyzer is read as "E".
3. Remove the EUT from the turn table and put the replacing antenna facing to measuring antenna at same height. Set the standard signal generator (SSG) at same frequency and transmit on then receive the signal
4. Swing the replacing antenna give a maximum receiving level.
5. Move the measuring antenna height up and down within ± 50 cm of replacing antenna height and swing it to find the maximum receiving level.
6. Set SSG output power at P_t to give the equivalent output level of "E" or calculate P_t with SSG output which gives the nearest of "E" and difference (± 1 dB). Record the P_t .
7. Calculate EIRP by the formula below $EIRP = G_t - L + P_t$.
G_t: gain of replacing antenna (dBi)
L: feeder loss between SSG and replacing antenna
P_t: Output power of the SSG
8. If the antenna for the EUT has circular polarization, sum of V-field and H-field will be result if measuring antenna is linear polarization.

4.6.4 TEST SETUP LAYOUT

For EUT radiation measurement

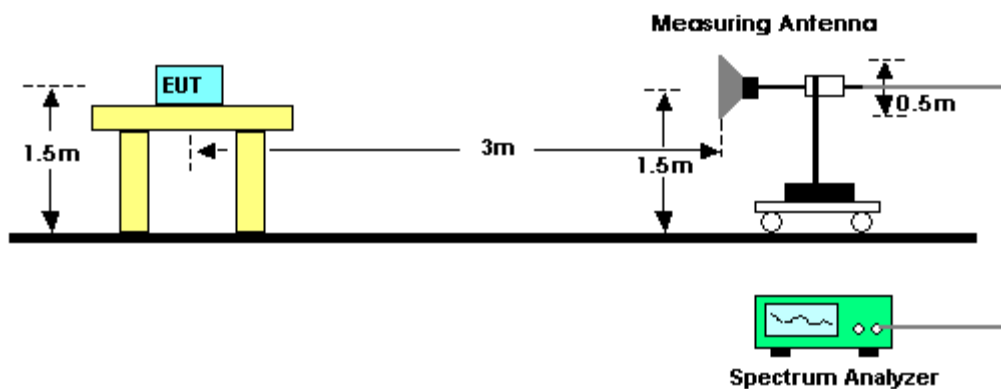

For standard antenna measurement

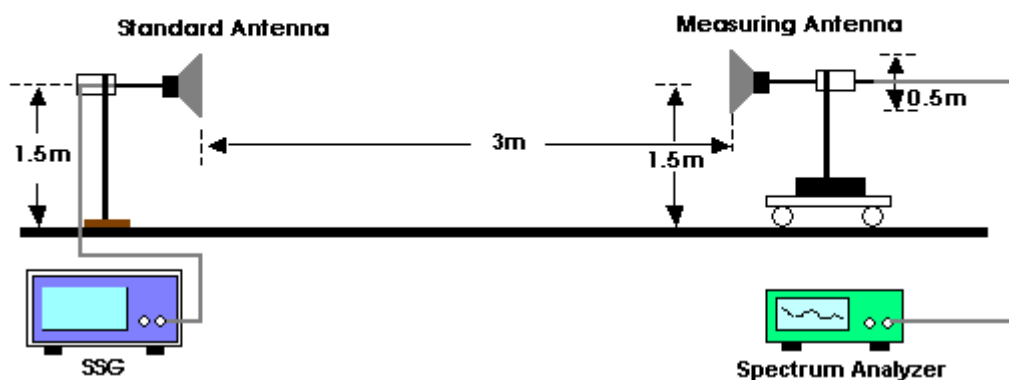

4.6.5 TEST DEVIATION

There is no deviation with the original standard.

4.6.6 EUT OPERATION DURING TEST

The EUT was programmed to be in continuously transmitting mode.

Temperature: 20°C Relative Humidity: 55% Test Pressure: 1010 hPa

4.6.7 RESULTS OF TRANSMISSION ANTENNA GAIN (EIRP ANTENNA POWER)

Method of measurement:	See MIC Notice No.88 Appendix No.43 Clause 10
Results:	Pass-Dipole antenna

Test Mode	802.11b/CH01,CH07,CH13				Remarks
Antenna Power (EIRP) (mW/MHz)	Test Voltage (V)	Test Frequency (MHz)			Low/Mid/Low of test frequency range
		2412	2442	2472	
	Normal Voltage	9.30641	8.03123	9.11553	Limit \leq 10 mW/MHz (10dBm/MHz)
	High Voltage	9.30641	8.04974	8.99046	
Low Voltage	9.37091	8.04974	9.07365		

Test Mode	802.11g/CH01,CH07,CH13				Remarks
Antenna Power (EIRP) (mW/MHz)	Test Voltage (V)	Test Frequency (MHz)			Low/Mid/Low of test frequency range
		2412	2442	2472	
	Normal Voltage	2.85616	2.53970	2.51063	Limit \leq 10 mW/MHz (10dBm/MHz)
	High Voltage	2.84303	2.53970	2.52803	
Low Voltage	2.83649	2.53386	2.49334		

Test Mode	802.11n(HT20)/CH01,CH07,CH13				Remarks
Antenna Power (EIRP) (mW/MHz)	Test Voltage (V)	Test Frequency (MHz)			Low/Mid/Low of test frequency range
		2412	2442	2472	
	Normal Voltage	1.48177	1.49893	1.54093	Limit \leq 10 mW/MHz (10dBm/MHz)
	High Voltage	1.53385	1.52329	1.53738	
Low Voltage	1.50932	1.51629	1.51280		

4.7 TRANSMISSION RADIATION ANGLE WIDTH (3DB BEAMWIDTH) MEASUREMENT

4.7.1 LIMIT

Item	Limits (See Article 49-20, Item1-f of the Ordinance Regulating Radio Equipment)
3dB antenna beam width	360/A (if A<1; then A=1) A= {EIRP Power [mW]/16.36 for DS, OFDM}

4.7.2 MEASURING INSTRUMENTS AND SETTING

Please refer to section 5 in this report. The following table is the setting of the spectrum analyzer.

Spectrum Parameter	Setting
Attenuation	Auto
Span	0 MHz
RBW	1 MHz
VBW	1 kHz
Y scale	5 dB
Detector	Peak
Trace	Max Hold

4.7.3 TEST PROCEDURES

Test method which surpass to Clause 22 of Annex No.43 of MIC Notification No.88.

1. Set EUT and measuring antenna at the same height and roughly facing each other.
2. Set spectrum analyzer with condition in section 4.7.2 and tune reference level to observe receiving signal position.
3. Rotate directions of the EUT horizontally and vertically to find the maximum receiving power.
4. Move the measuring antenna height up and down within ± 50 cm of EUT height and swing it to find the maximum output of measuring antenna. The output level at the spectrum analyzer is read as "E"
5. Calculate permitted radiation angle in horizontal and vertical using EIRP measured in another test method.
6. Calculate 3dB antenna beam width by the formula below $360/A$ (If $A < 1$; then $A = 1$).
 $A = \{ \text{EIRP Power [mW]} / 16.36 \text{ for DS, OFDM} \}$ or
 $A = \{ \text{EIRP Power [mW]} / 4.9 \text{ for FH} \}$

4.7.4 TEST SETUP LAYOUT

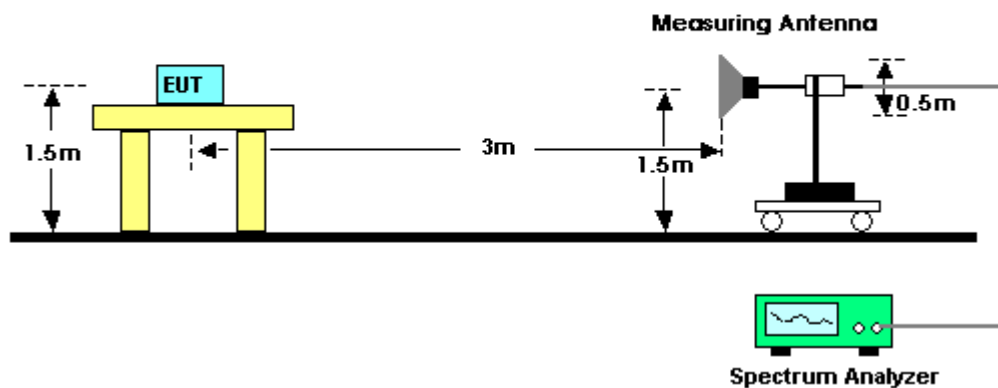

4.7.5 TEST DEVIATION

There is no deviation with the original standard.

4.7.6 EUT OPERATION DURING TEST

The EUT was programmed to be in continuously transmitting mode.

Temperature: 20°C Relative Humidity: 55% Test Pressure: 1010 hPa

4.7.7 TEST RESULT OF TRANSMISSION RADIATION ANGLE WIDTH (3DB BEAMWIDTH)

Method of measurement:	See MIC Notice No.88 Appendix No.43 Clause 22
Results:	Pass-Dipole antenna

Antenna Power	Antenna			
A (dBm/MHz)	Type	Gain B (dBi)	3dB Beam-width Horizontal (Degree)	3dB Beam-width Vertical (Degree)
9.72	Dipole	2.15	-	-

Total Gain D=B-C (dBi)	EIRP F=A+D (dBm/MHz)	Permitted Angle (Degree)	Judgment
2.15	11.87	360.00	Good

4.8 RADIO INTERFERENCE PREVENTION CAPABILITY MEASUREMENT

4.8.1 LIMIT

Item	Limits (See Article 9-4, Item9-C of the Ordinance Regulating Radio Equipment)
Identification code	≥ 48 bits

4.8.2 MEASURING ID CODE SOFTWARE

PC with NetTool	Setting
MAC IP List	MAC Scan

4.8.3 TEST PROCEDURES

Test method which surpass to Clause 23 of Annex No.43 of MIC Notification No.88.

1. In the case that the EUT has the function of automatically transmitting the identification code: a. Transmit the predetermined identification codes form EUT. b. Check the transmitted identification codes with the demodulator.
2. In the case of receiving the identification ocde: a. Transmit the predetermined identification codes form the counterpart. b . Check if communication is normal. c. Transmit the signals other than predetermined ID codes form the counterpart. d. check if the EUT stops the transmission, or if it displays that idnetification codes are different from the predetermined ones.

4.8.4 TEST SETUP LAYOUT

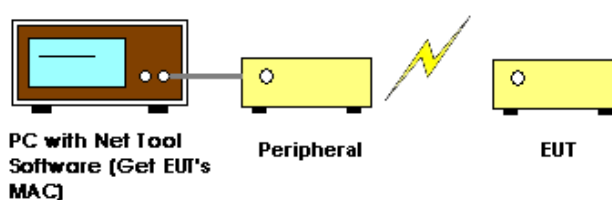

4.8.5 TEST DEVIATION

There is no deviation with the original standard.

4.8.6 EUT OPERATION DURING TEST

The EUT was programmed to be in normal transmitting mode.

Temperature: 20°C Relative Humidity: 55% Test Pressure: 1010 hPa

4.8.7 TEST RESULT OF RADIO INTERFERENCE PREVENTION CAPABILITY

Test Power:	Normal Voltage
Test Mode:	802.11b
Test Result:	Good (identification code: [6C:0B:84:1A:EF:34])

```
C:\Users\Eric>particle serial monitor
Opening serial monitor for com port: "COM9"
ress is:6C:B:84:1A:EF:34
The mac address is:6C:B:84:1A:EF:34
The mac address is:6C:B:84:1A:EF:34
The mac address is:6C:B:84:1A:EF:34
The mac address is:6C:B:84:1A:EF:34
The mac address is:6C:B:84:1A:EF:34
The mac address is:6C:B:84:1A:EF:34
The mac address is:6C:B:84:1A:EF:34
The mac address is:6C:B:84:1A:EF:34
The mac address is:6C:B:84:1A:EF:34
The mac address is:6C:B:84:1A:EF:34
```

4.9 CARRIER SENSE CAPABILITY MEASUREMENT

4.9.1 LIMIT

Item	Limits (See Article 49-20, Item1-k of the Ordinance Regulating Radio Equipment)
Carrier Sense	Good – EUT stop RF transmission signal after carrier inject to EUT. (On $22.79+Gr-20*\log(f)$ [dBm] (Gr: dBi; f: MHz) or 100mV/m)
Remarks	This test item will be applied to OFDM, $26\text{MHz} < \text{BW} \leq 38\text{MHz}$

4.9.2 MEASURING INSTRUMENTS AND SETTING

Please refer to section 5 in this report. The following table is the setting of the spectrum analyzer.

Spectrum Parameter	Setting
Attenuation	Auto
RBW / VBW	1 MHz
Span	0 MHz
Sweep	Continuous
Detector	Peak
Trigger mode	Video

4.9.3 TEST PROCEDURES

Test method which surpass to Clause 8,9 of Annex No.43 of MIC Notification No.88.

1. SSG adjusted the frequency as same as the EUT transmitted signal and emitted the absence of modulation from SSG and power level is ($22.79+Gr-20*\log(f)$ [dBm] (Gr: dBi; f: MHz). Then turn off the RF signal of SSG.
2. EUT have transmitted the maximum modulation signal and fixed channelize.
3. Setting of SA is following as: RBW:1MHz / VBW:1MHz / SPAN: 50MHz / AT: 10dB / Ref: 0dBm / Sweep time: Auto / Sweep Mode: Continuous sweep / Detect mode: Positive peak.
4. SSG RF Signal On.
5. EUT shall be stop the transmitted any signal and SSG RF Signal Off. Then EUT will be continuous transmitted signal.

4.9.4 TEST SETUP LAYOUT

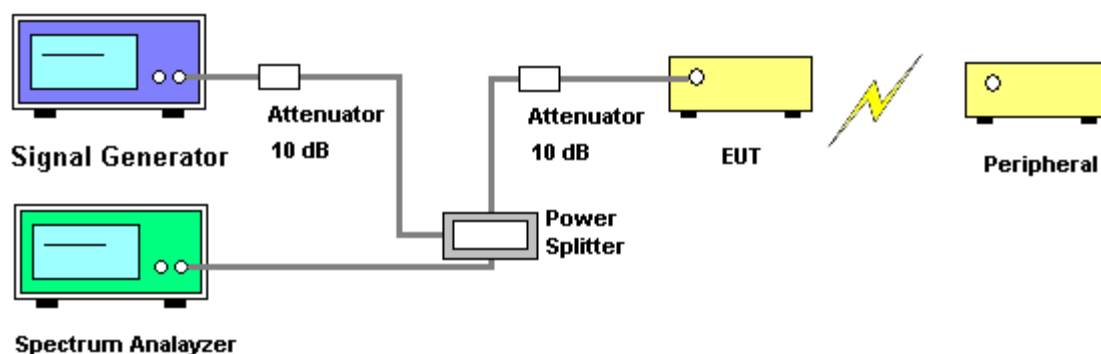

4.9.5 TEST DEVIATION

There is no deviation with the original standard.

4.9.6 EUT OPERATION DURING TEST

The EUT was programmed to be in normal transmitting mode.

Temperature: 20°C Relative Humidity: 55% Test Pressure: 1010 hPa

4.9.7 TEST RESULT OF CARRIER SENSE CAPABILITY

Test Power:	Normal Voltage
Test Mode:	802.11b
Test Result:	Good

4.10 CONSTRUCTION PROTECTION CONFIRMATION METHOD

4.10.1 LIMIT

(See Article 49-20, Item1-a of the Ordinance Regulating Radio Equipment)

The high-frequency section and modulation section of the radio equipment except for the antenna system shall not be capable of being opened easily.

4.10.2 CONFIRMATION METHOD

The RF and modulation portions are protected against illegal modification as following method:

Tick the appropriate box	
	1. Sealed with special screws.
	2. Plastic chassis is being welded using ultrasonic waves.
	3. Chassis is glued using a special adhesive.
	4. Metal covers are spot-fused.
	5. Cover is specially interlocked.
X	6. RF and Modulation components are covered with shielding case and this shielding case is soldered.
	7. Shield case is welded at RF and modulation parts, and ID-ROM is welded using the BGA Method.
	8. Shield case is welded at RF and modulation parts, and ID-ROM is glued at its lead with a special adhesive
	9. Shield case is welded at RF and modulation parts, and ID-ROM is glued with a non-transparent laminating agent.
	10. RF and Modulation parts are mounted on PCB with surface mount technology, and there is no any adjustable part on PCB or adjustable parts are not exposed.

5. LIST OF MEASURING EQUIPMENTS

Kind of Equipment	Manufacturer	Model No.	Serial No.	Calibrated Date	Validity Date	Calibration Agency
Spectrum Analyzer	R&S	FSP40	100185	Oct. 11, 2015	Oct. 11, 2016	CHINA CEPREI LABORATORY
Test Cable	emci	EMC104-SM-S M-9000(0.01G Hz-26.5GHz)	C-100	N/A	N/A	2.4G
power Meter	ANRITSU	ML2495A	1128009	Mar. 28, 2015	Mar. 28, 2016	CEPREI Calibration and Testing Center
Pulse Power Sensor	ANRITSU	MA 2411B	1027500	Mar. 28, 2015	Mar. 28, 2016	CEPREI Calibration and Testing Center
Signal Generator	R&S	SMR40	100504	Mar. 28, 2015	Mar. 28, 2016	CEPREI Calibration and Testing Center
DC power supply	GW Instek	GPC-3030DN	EK880675	Oct.13, 2015	Oct. 13, 2016	CHINA CEPREI LABORATORY
Attenuator	WOKEN	6SM3502	VAS1214NL	Mar. 10, 2015	Mar. 10, 2016	CEPREI Calibration and Testing Center
Antenna	EMCO	3142C	66462	Mar. 28, 2015	Mar. 28, 2016	CEPREI Calibration and Testing Center
Antenna	EMCO	3142C	66464	Mar. 28, 2015	Mar. 28, 2016	CEPREI Calibration and Testing Center

Note

1. The calibration interval of the above test instruments is 12 months and the calibrations are traceable to NML/ROC and NIST/USA.

6. EUT TEST PHOTO

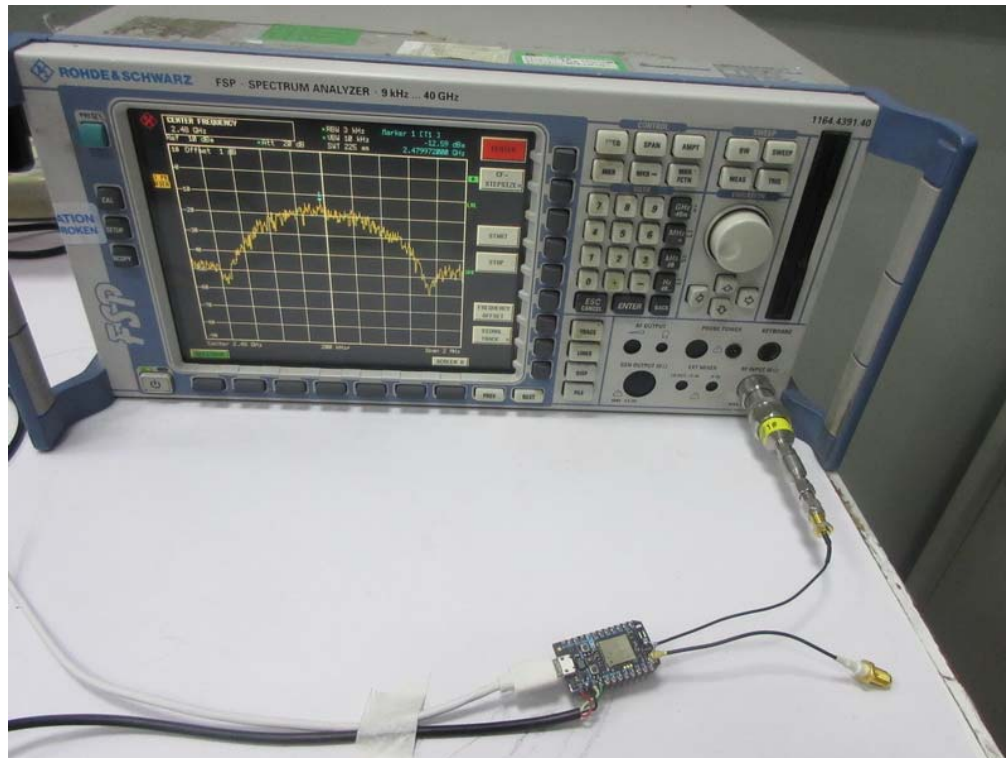

ATTACHMENT A - FREQUENCY TOLERANCE

For Chip antenna

Test Mode:	802.11b/CH01,CH07,CH13
------------	------------------------

Test Voltage (V)	Normal Voltage			Remarks
Test Frequency (MHz)	2412	2442	2472	Low/Mid/High of test frequency range
Measured Frequency (MHz)	2411.9598	2442.1198	2471.9788	-
Frequency Tolerance (ppm)	-16.67	49.06	-8.58	Limit \leq 50 ppm

Test Voltage (V)	High Voltage			Remarks
Test Frequency (MHz)	2412	2442	2472	Low/Mid/High of test frequency range
Measured Frequency (MHz)	2411.9250	2442.0390	2471.9344	-
Frequency Tolerance (ppm)	-31.09	15.97	-26.54	Limit \leq 50 ppm

Test Voltage (V)	Low Voltage			Remarks
Test Frequency (MHz)	2412	2442	2472	Low/Mid/High of test frequency range
Measured Frequency (MHz)	2412.0346	2442.0950	2471.9486	-
Frequency Tolerance (ppm)	14.34	38.90	-20.79	Limit \leq 50 ppm

Normal Voltage CH01

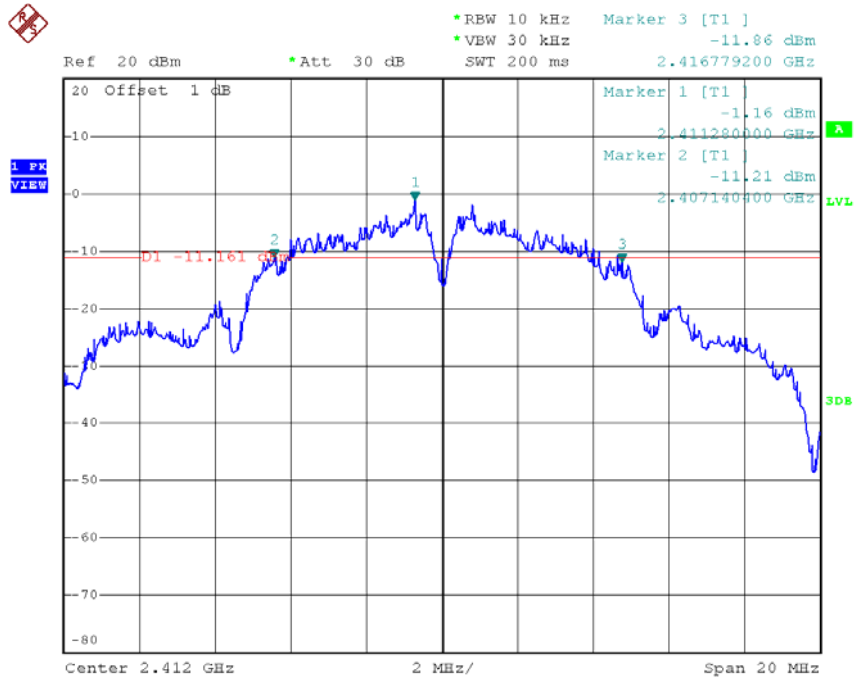

Date: 14.NOV.2015 15:30:47

Normal Voltage CH07

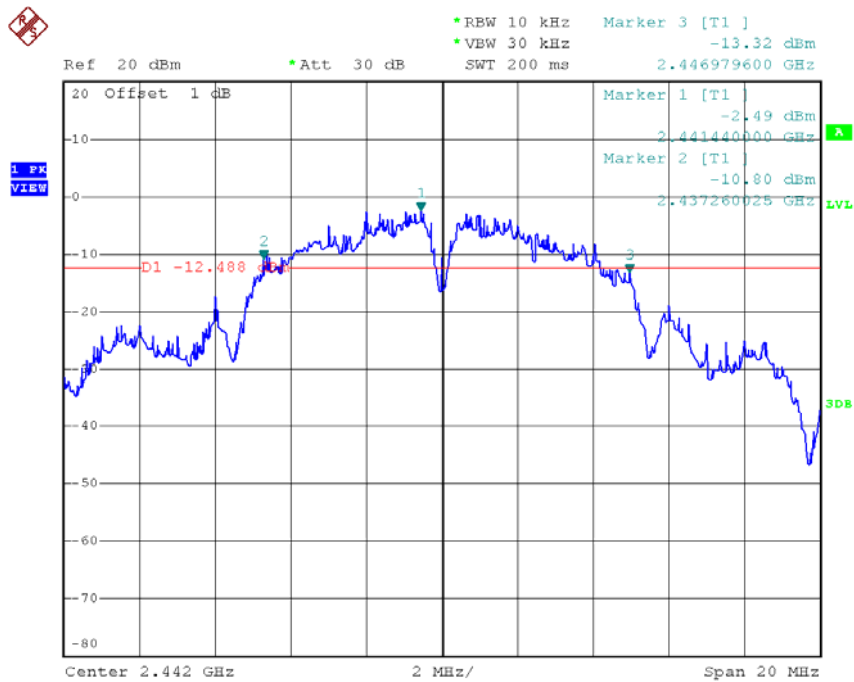

Date: 14.NOV.2015 15:44:21

Normal Voltage CH13

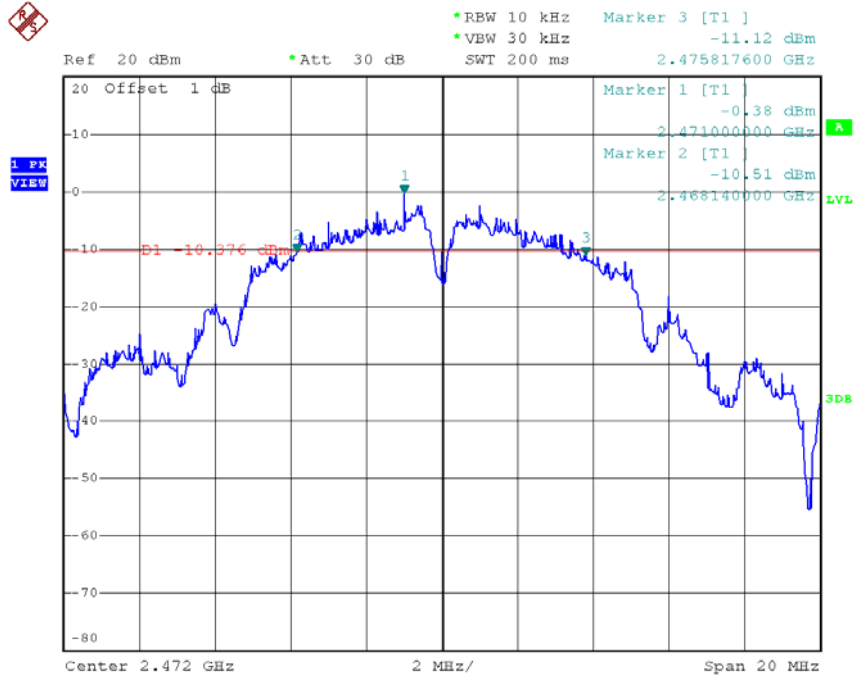

Date: 14.NOV.2015 16:20:04

High Voltage CH01

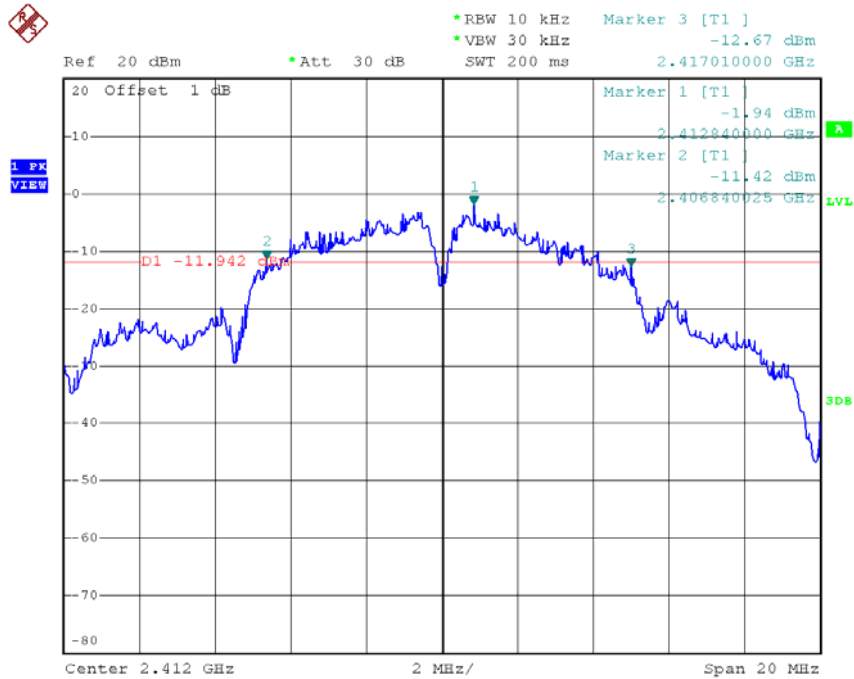

Date: 14.NOV.2015 15:28:26

High Voltage CH07

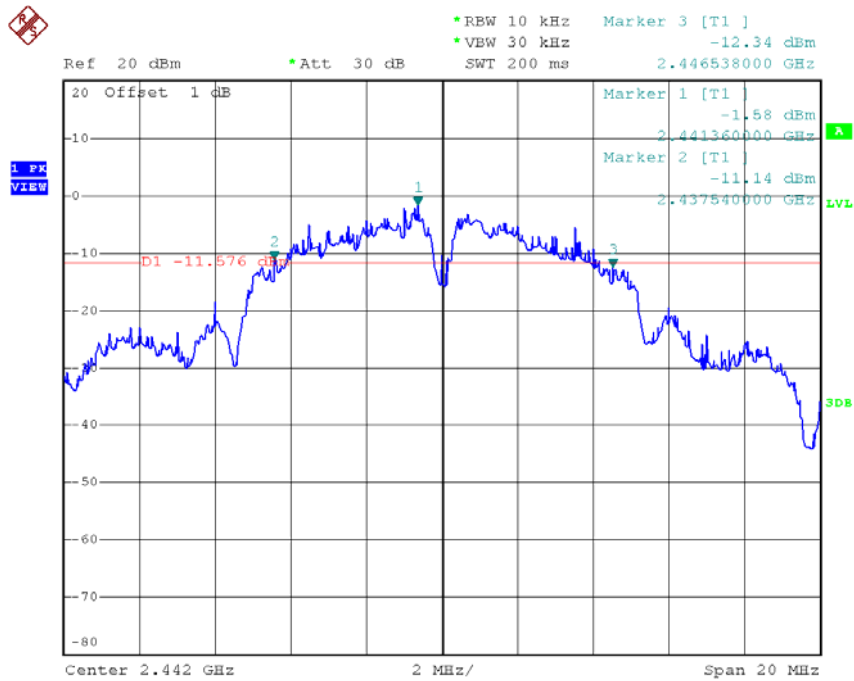

Date: 14.NOV.2015 15:40:04

High Voltage CH13

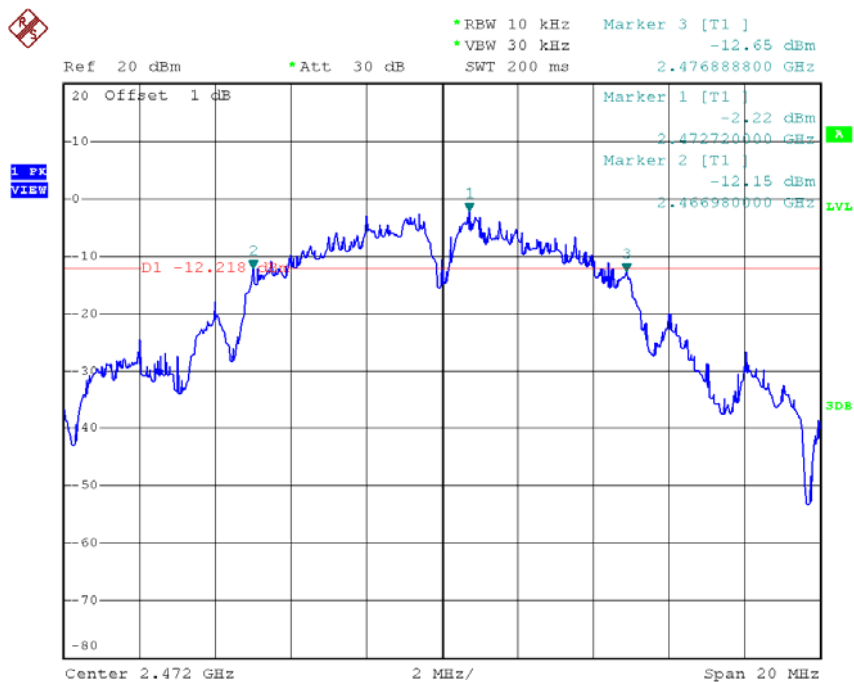

Date: 14.NOV.2015 16:16:23

Low Voltage CH01

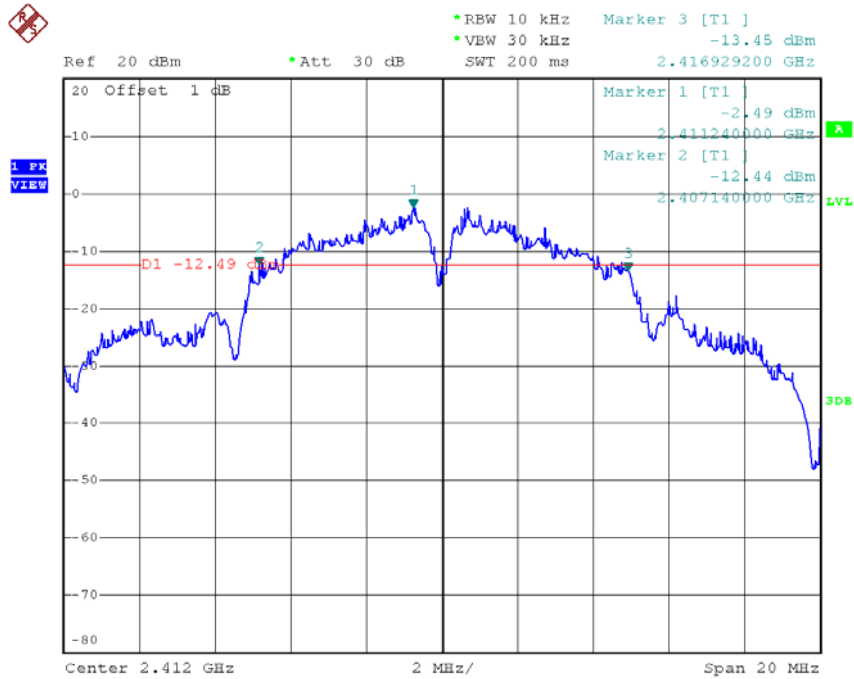

Date: 14.NOV.2015 15:34:45

Low Voltage CH07

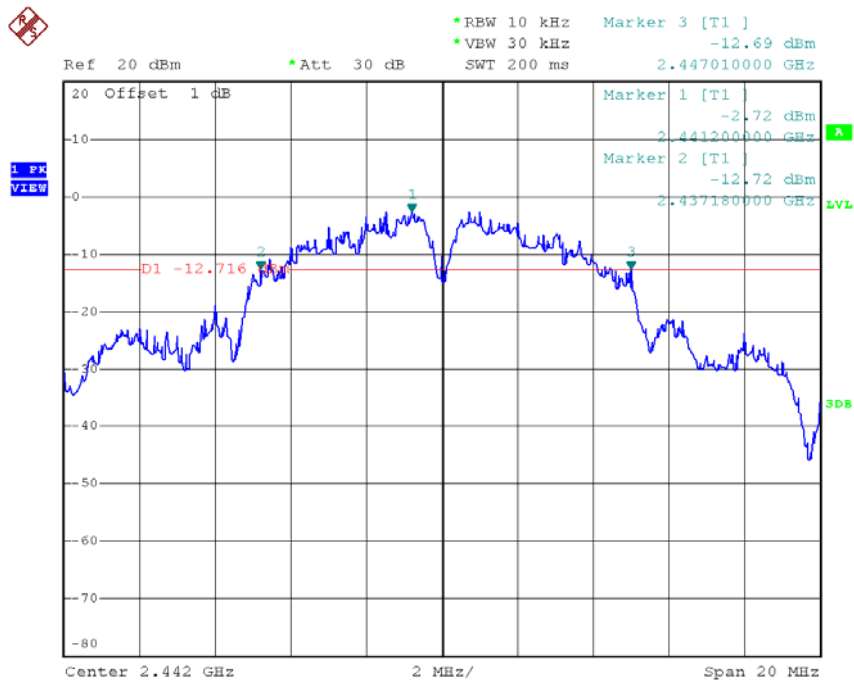

Date: 14.NOV.2015 15:48:28

Low Voltage CH13

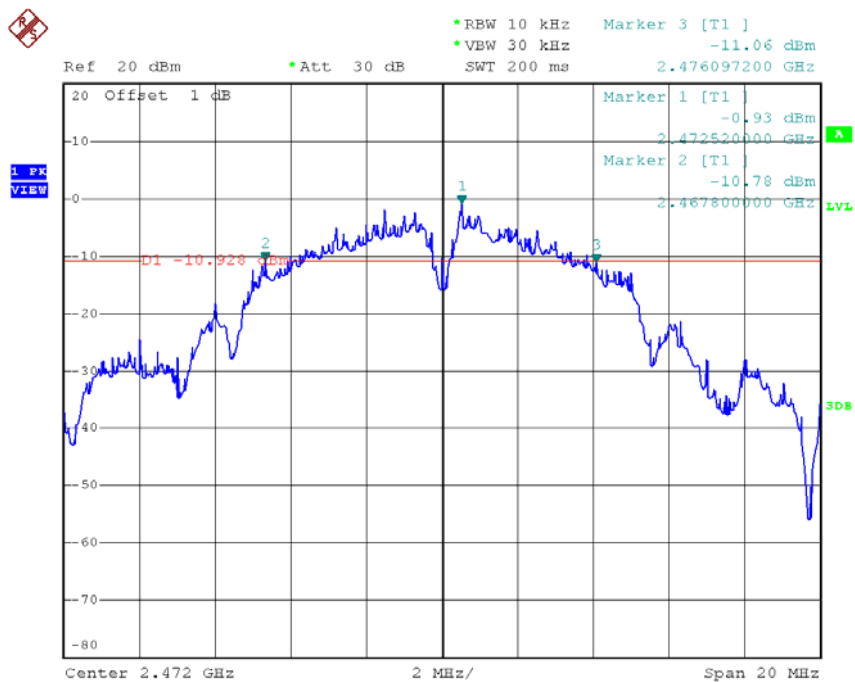

Date: 14.NOV.2015 16:26:30

Test Mode:	802.11g/CH01,CH07,CH13
------------	------------------------

Test Voltage (V)	Normal Voltage			Remarks
Test Frequency (MHz)	2412	2442	2472	Low/Mid/High of test frequency range
Measured Frequency (MHz)	2411.9750	2442.0150	2472.0150	-
Frequency Tolerance (ppm)	-10.36	6.14	6.07	Limit \cong 50 ppm

Test Voltage (V)	High Voltage			Remarks
Test Frequency (MHz)	2412	2442	2472	Low/Mid/High of test frequency range
Measured Frequency (MHz)	2412.1198	2442.0200	2472.0000	-
Frequency Tolerance (ppm)	49.67	8.18	-0.01	Limit \cong 50 ppm

Test Voltage (V)	Low Voltage			Remarks
Test Frequency (MHz)	2412	2442	2472	Low/Mid/High of test frequency range
Measured Frequency (MHz)	2411.9148	2441.9948	2471.9950	-
Frequency Tolerance (ppm)	-35.32	-2.13	-2.02	Limit \cong 50 ppm

Normal Voltage CH01

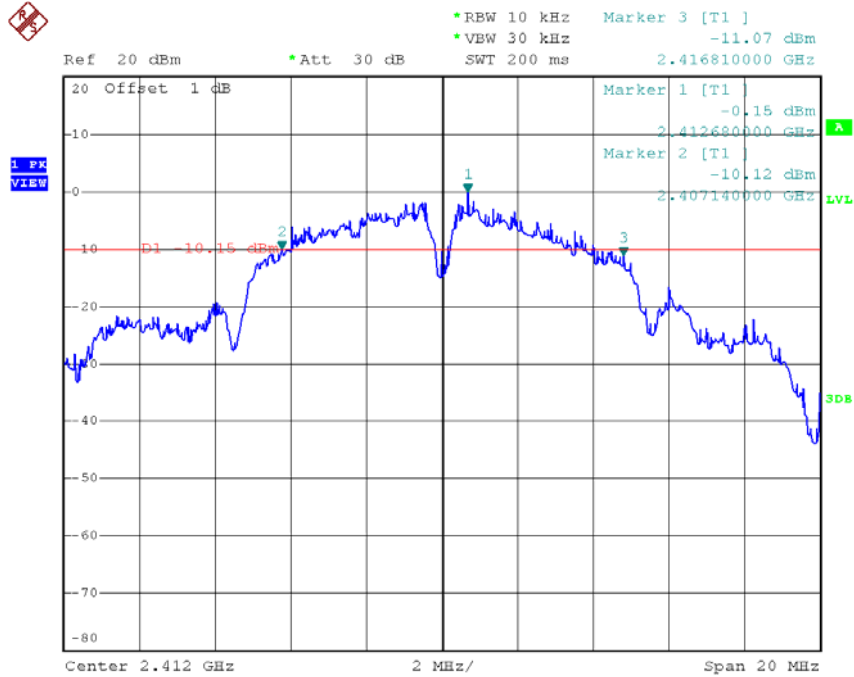

Date: 17.NOV.2015 16:01:10

Normal Voltage CH07

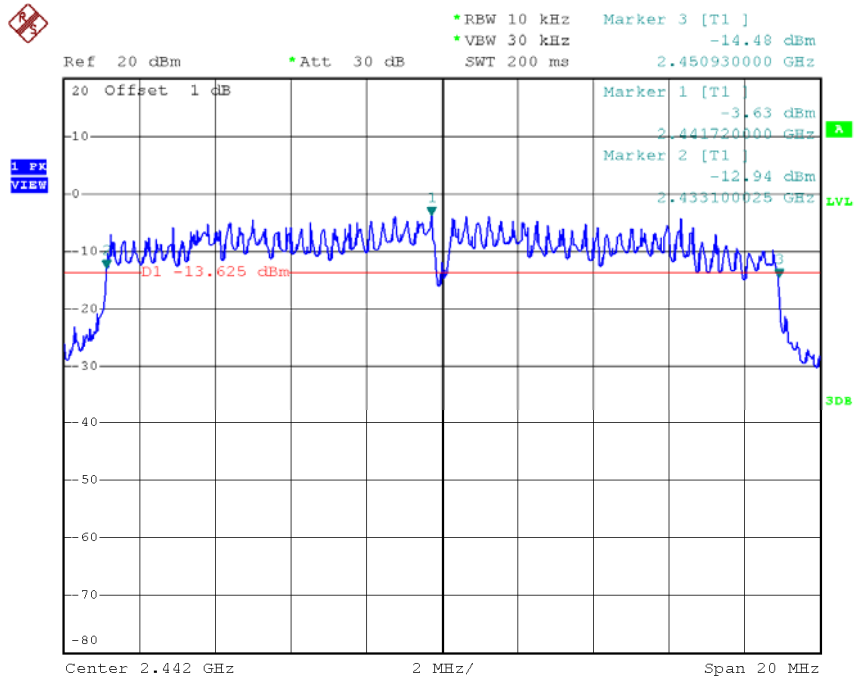

Date: 17.NOV.2015 16:13:40

Normal Voltage CH13

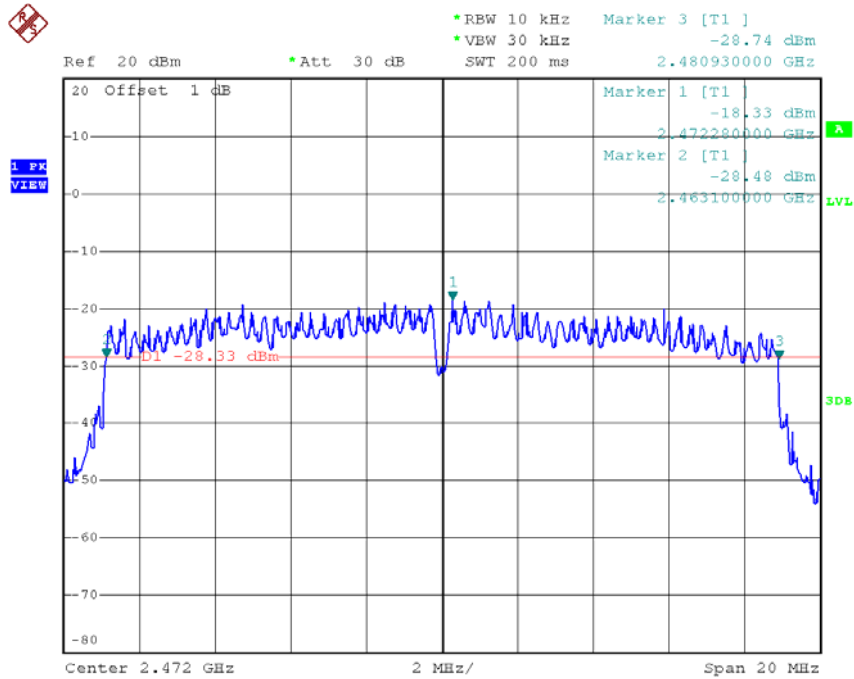

Date: 17.NOV.2015 16:26:35

High Voltage CH01



Date: 17.NOV.2015 15:56:57

High Voltage CH07

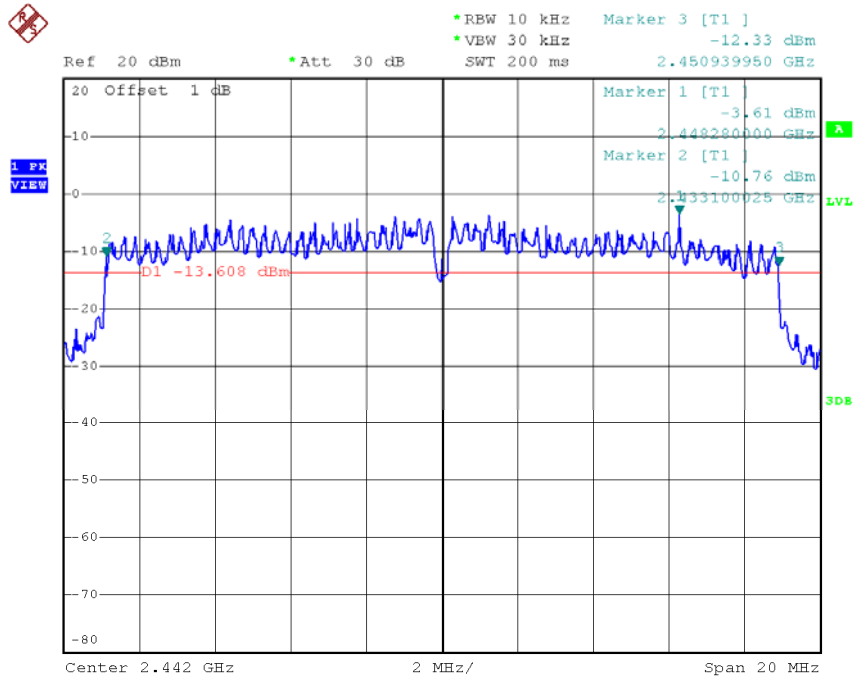

Date: 17.NOV.2015 16:10:39

High Voltage CH13

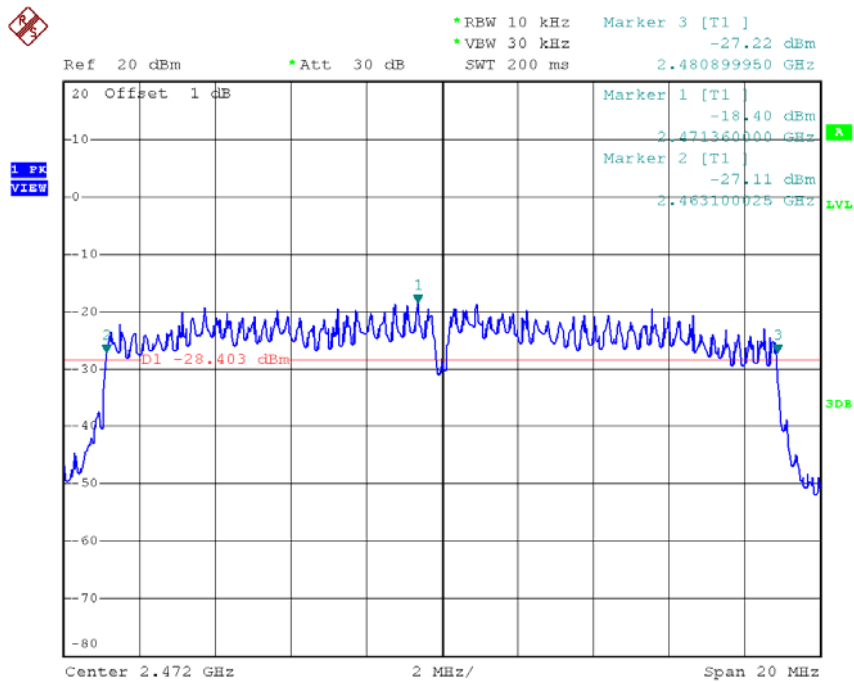

Date: 17.NOV.2015 16:23:50

Low Voltage CH01

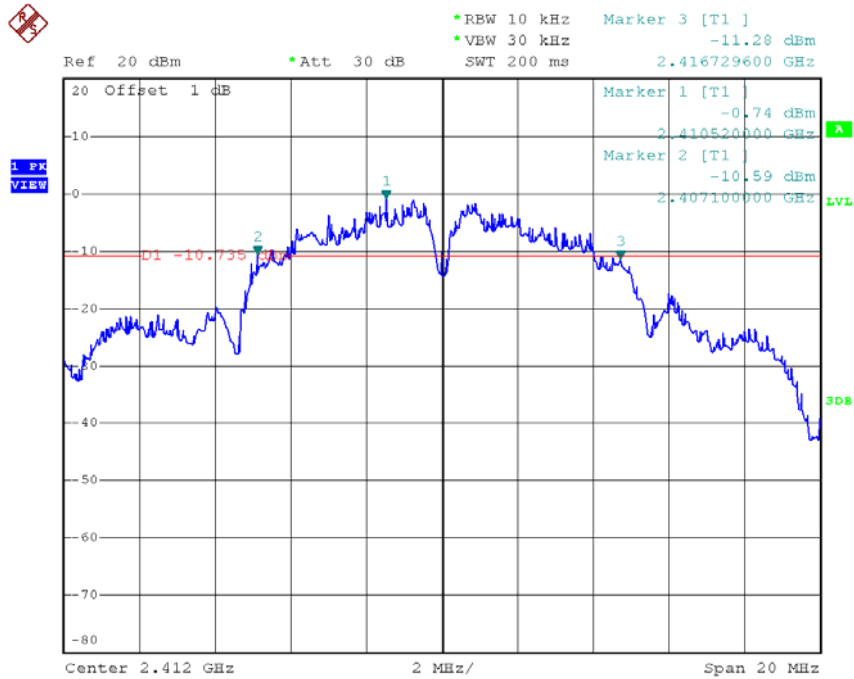

Date: 17.NOV.2015 16:04:33

Low Voltage CH07

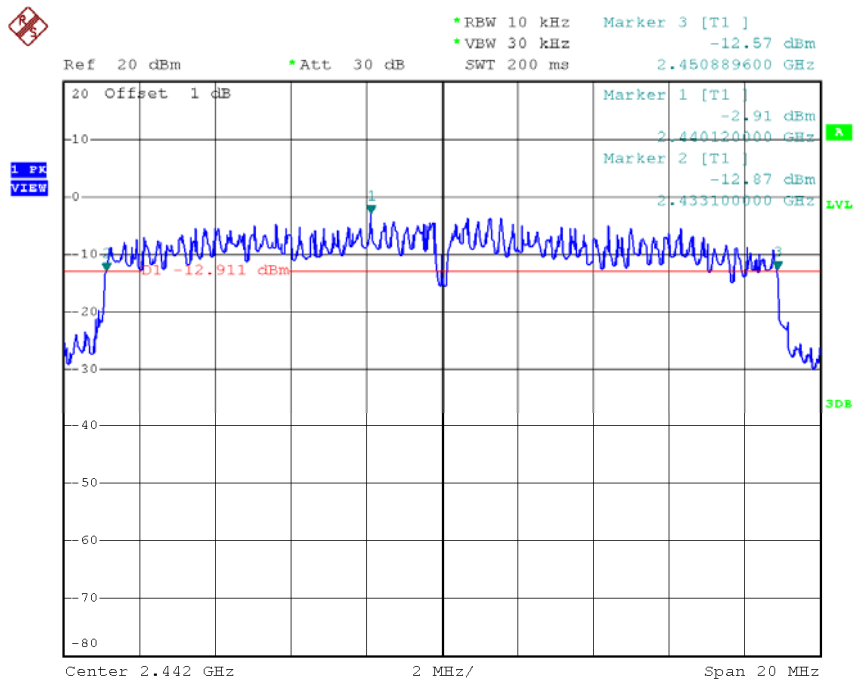

Date: 17.NOV.2015 16:16:13

Low Voltage CH13

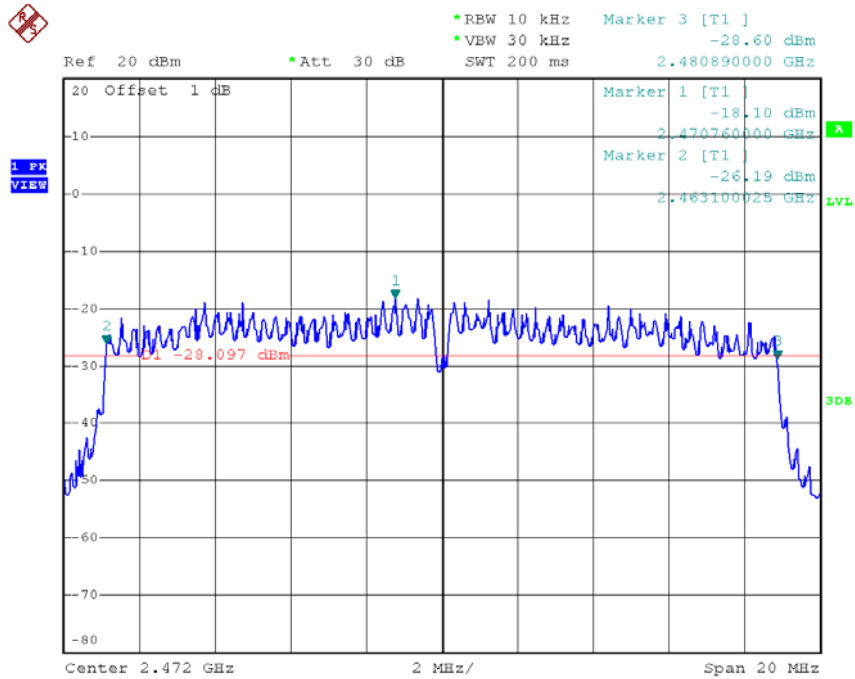

Date: 17.NOV.2015 16:29:15

Test Mode:	802.11n(HT20)/CH01,CH07,CH13
------------	------------------------------

Test Voltage (V)	Normal Voltage			Remarks
Test Frequency (MHz)	2412	2442	2472	Low/Mid/High of test frequency range
Measured Frequency (MHz)	2411.9948	2442.0200	2472.0000	-
Frequency Tolerance (ppm)	-2.16	8.18	-0.01	Limit \cong 50 ppm

Test Voltage (V)	High Voltage			Remarks
Test Frequency (MHz)	2412	2442	2472	Low/Mid/High of test frequency range
Measured Frequency (MHz)	2411.9948	2441.9948	2472.0000	-
Frequency Tolerance (ppm)	-2.16	-2.13	-0.01	Limit \cong 50 ppm

Test Voltage (V)	Low Voltage			Remarks
Test Frequency (MHz)	2412	2442	2472	Low/Mid/High of test frequency range
Measured Frequency (MHz)	2412.0000	2442.0150	2471.9950	-
Frequency Tolerance (ppm)	-0.01	6.14	-2.02	Limit \cong 50 ppm

Normal Voltage CH01

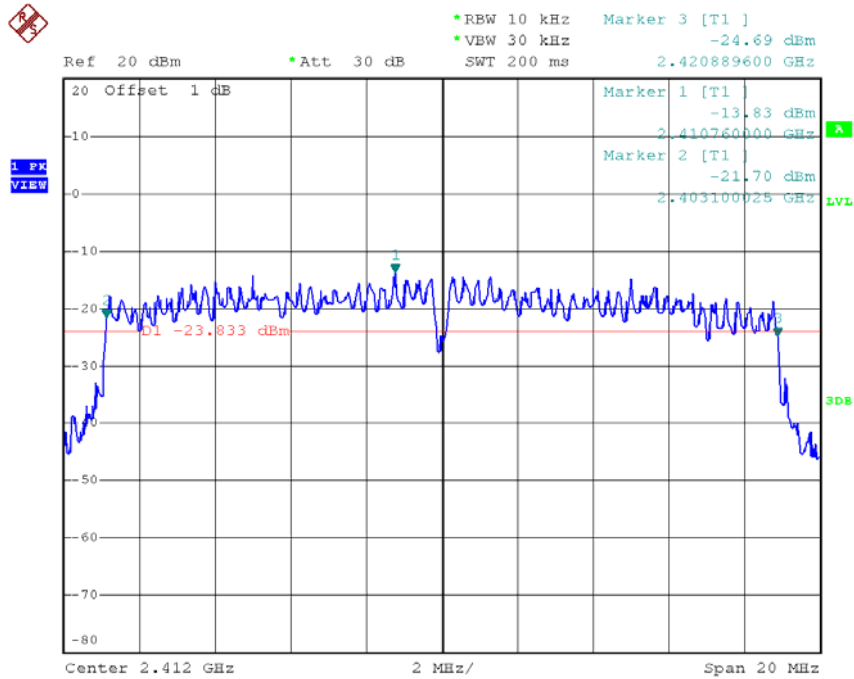

Date: 17.NOV.2015 17:13:56

Normal Voltage CH07

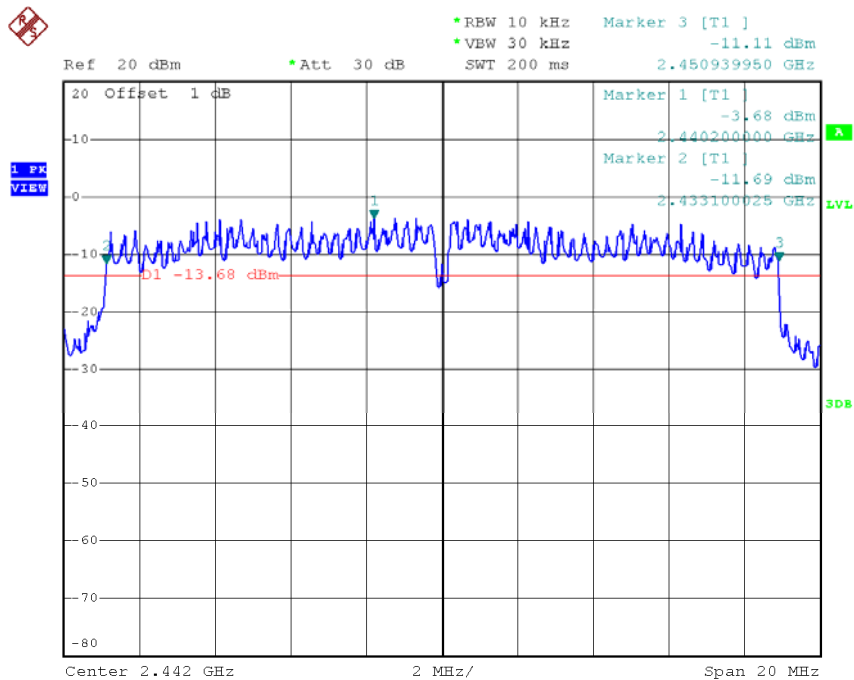

Date: 17.NOV.2015 17:29:56

Normal Voltage CH13

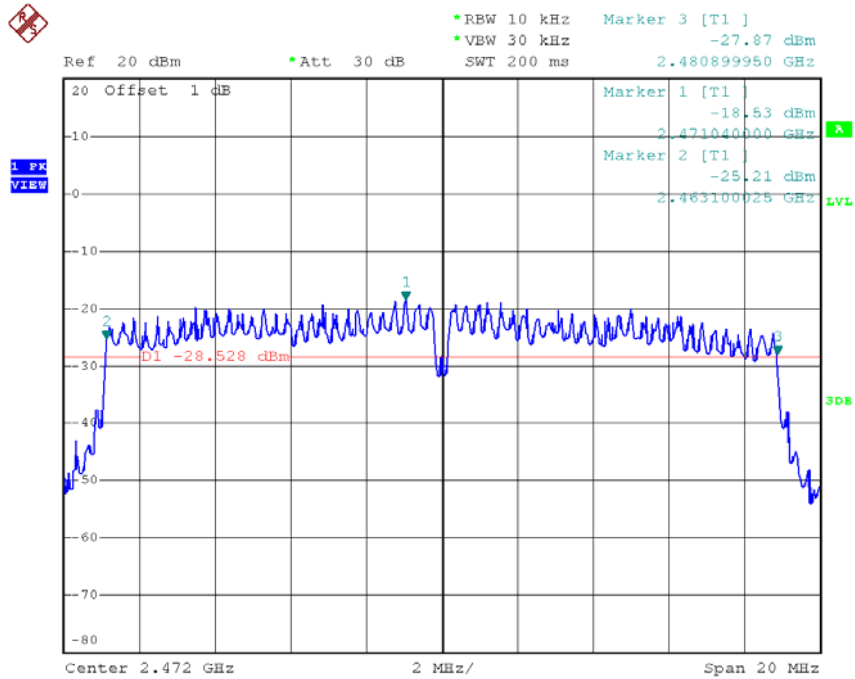

Date: 17.NOV.2015 18:04:51

High Voltage CH01

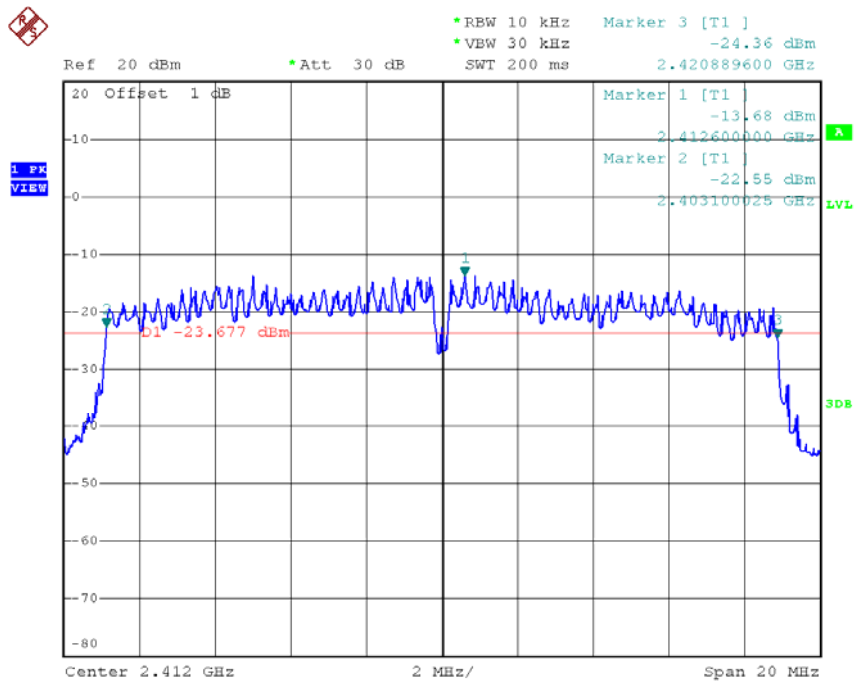

Date: 17.NOV.2015 17:11:12

High Voltage CH07

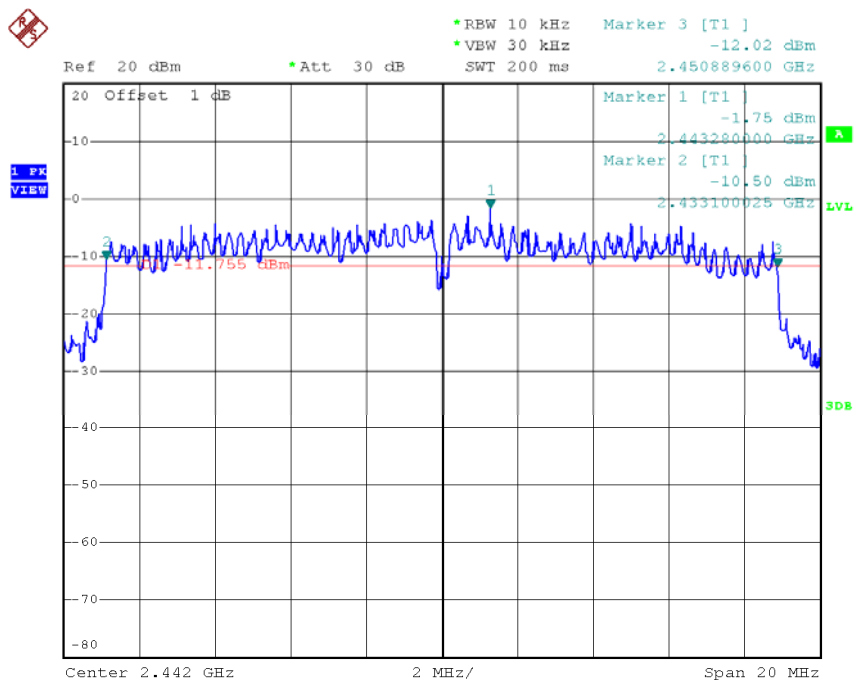

Date: 17.NOV.2015 17:27:12

High Voltage CH13

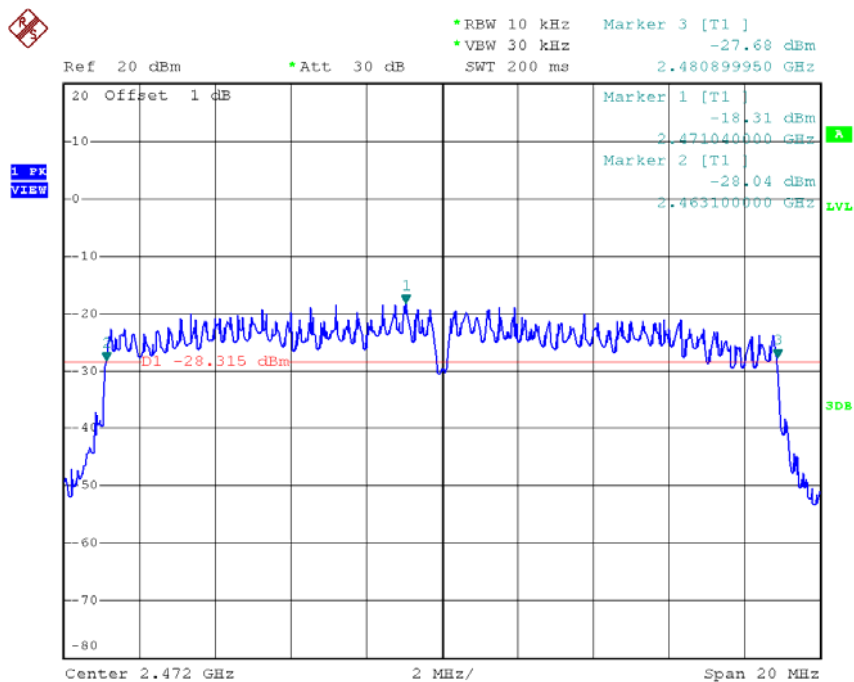

Date: 17.NOV.2015 18:02:06

Low Voltage CH01

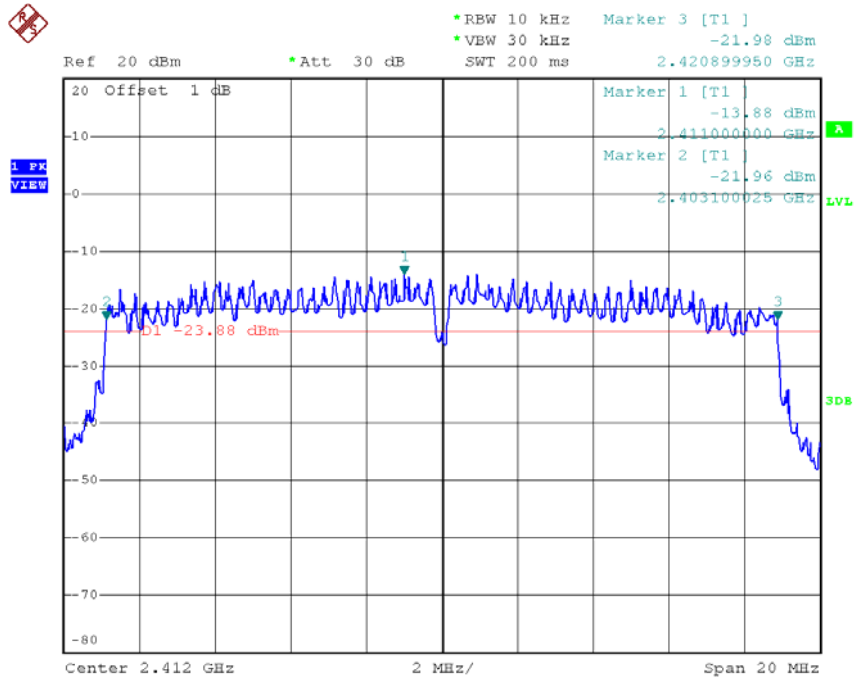

Date: 17.NOV.2015 17:16:45

Low Voltage CH07

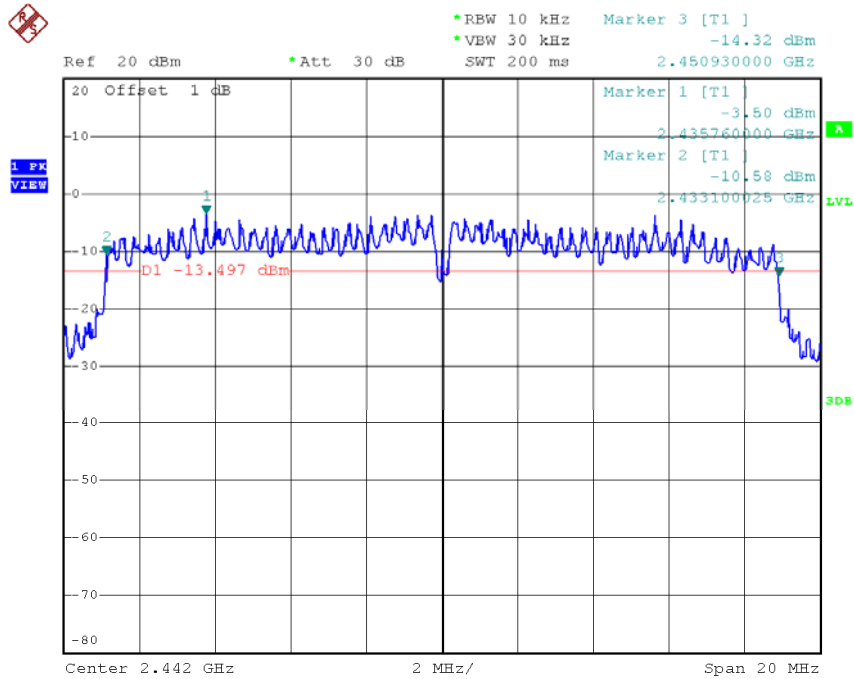

Date: 17.NOV.2015 17:48:57

Low Voltage CH13

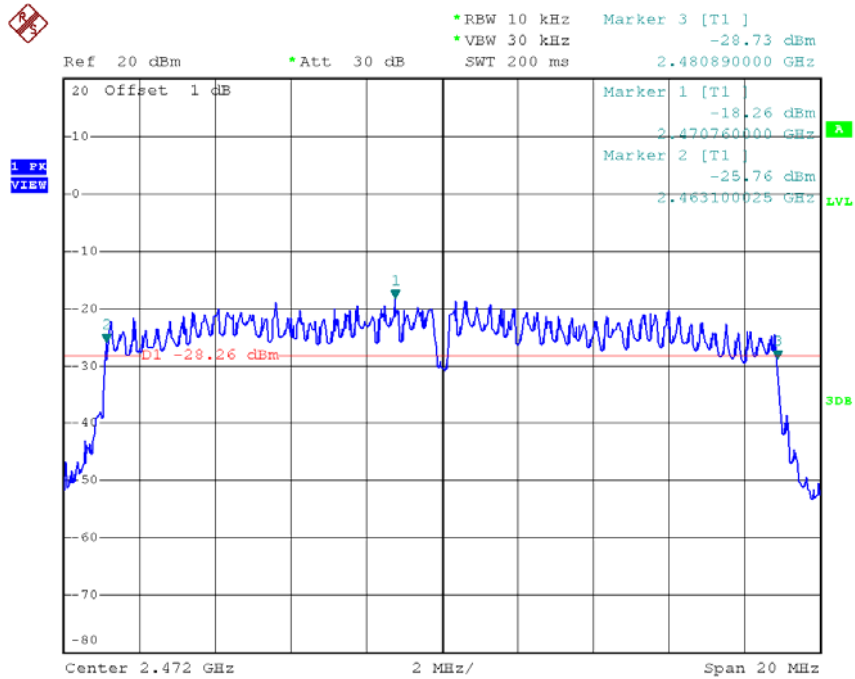

Date: 17.NOV.2015 18:07:44

For Dipole antenna

Test Mode:	802.11b/CH01,CH07,CH13
------------	------------------------

Test Voltage (V)	Normal Voltage			Remarks
Test Frequency (MHz)	2412	2442	2472	Low/Mid/High of test frequency range
Measured Frequency (MHz)	2411.9544	2442.1168	2471.9763	-
Frequency Tolerance (ppm)	-18.91	47.83	-9.59	Limit \leq 50 ppm

Test Voltage (V)	High Voltage			Remarks
Test Frequency (MHz)	2412	2442	2472	Low/Mid/High of test frequency range
Measured Frequency (MHz)	2412.0148	2442.0375	2471.9353	-
Frequency Tolerance (ppm)	6.14	15.36	-26.17	Limit \leq 50 ppm

Test Voltage (V)	Low Voltage			Remarks
Test Frequency (MHz)	2412	2442	2472	Low/Mid/High of test frequency range
Measured Frequency (MHz)	2411.9396	2442.0956	2471.9600	-
Frequency Tolerance (ppm)	-25.04	39.15	-16.20	Limit \leq 50 ppm

Normal Voltage CH01

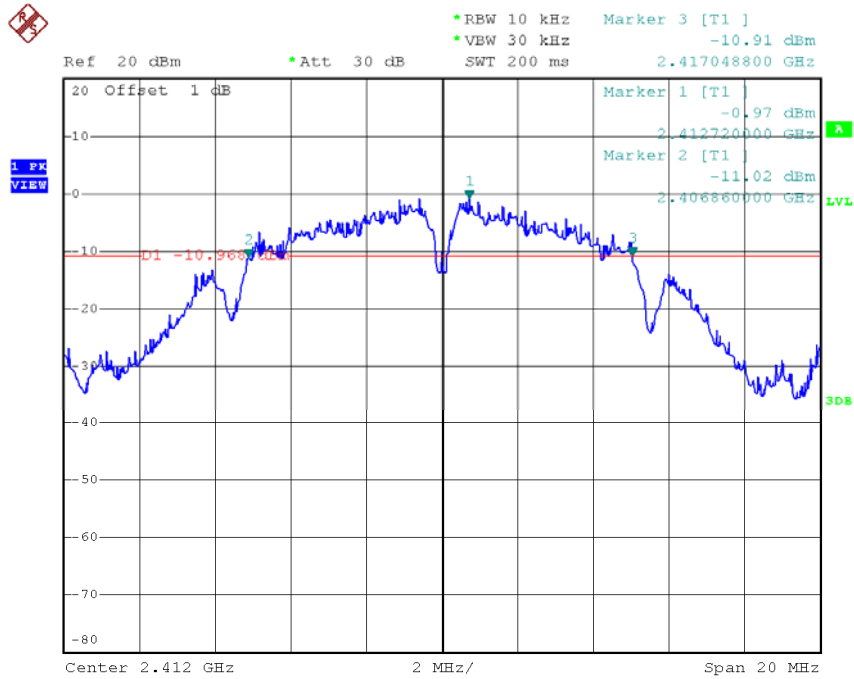

Date: 12.NOV.2015 17:19:27

Normal Voltage CH07

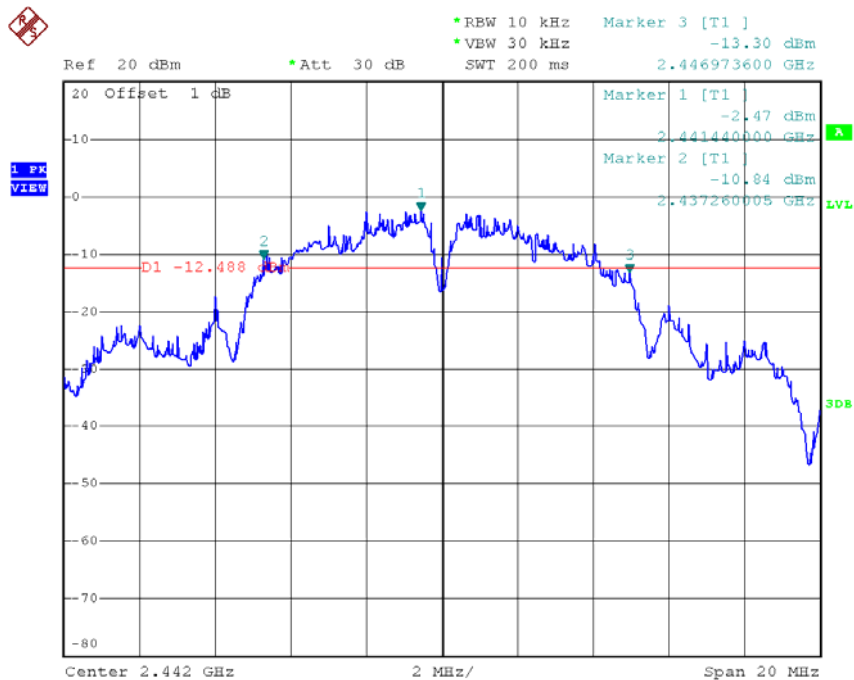

Date: 14.NOV.2015 15:44:21

Normal Voltage CH13

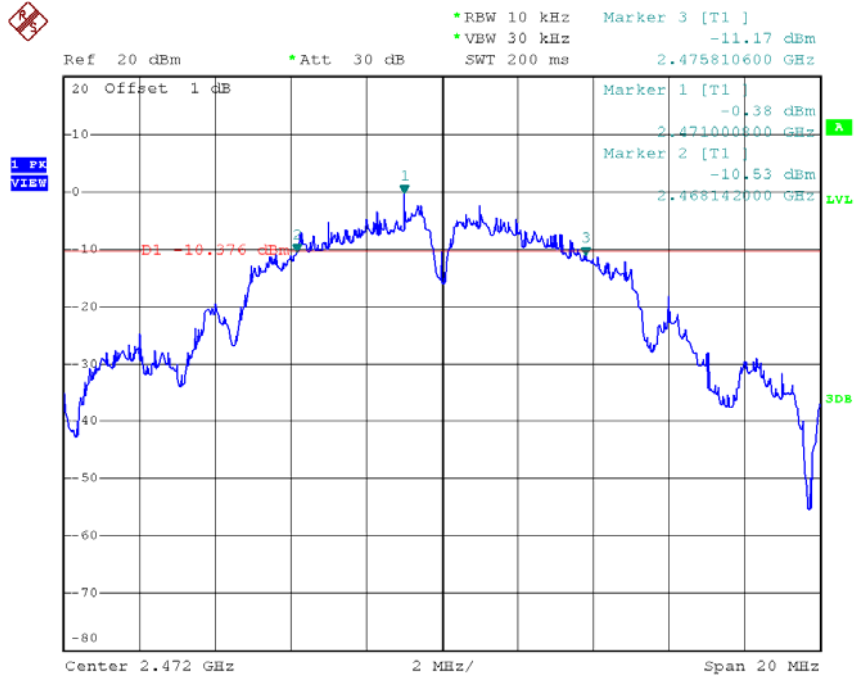

Date: 14.NOV.2015 16:20:04

High Voltage CH01

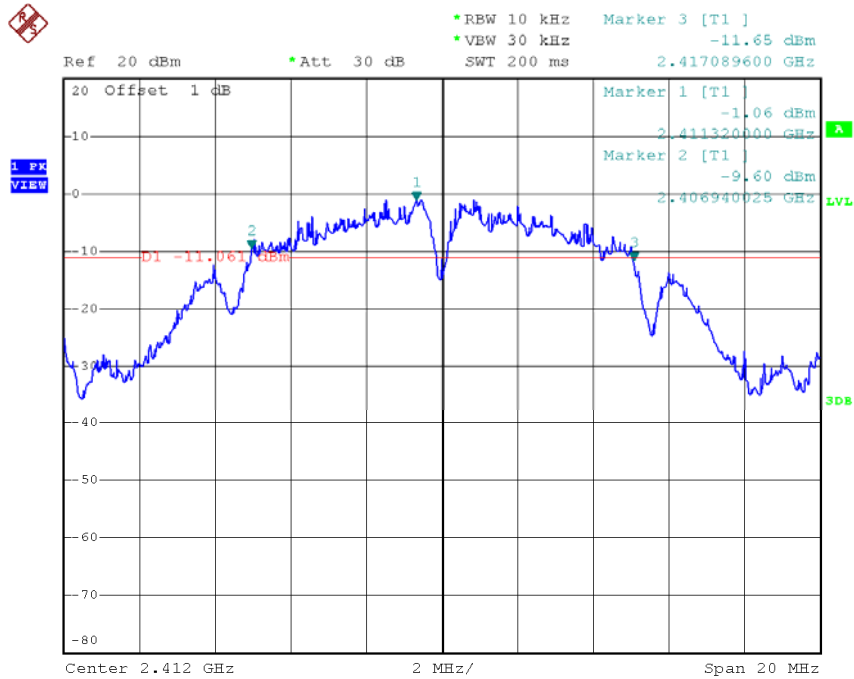

Date: 12.NOV.2015 17:21:13

Low Voltage CH01

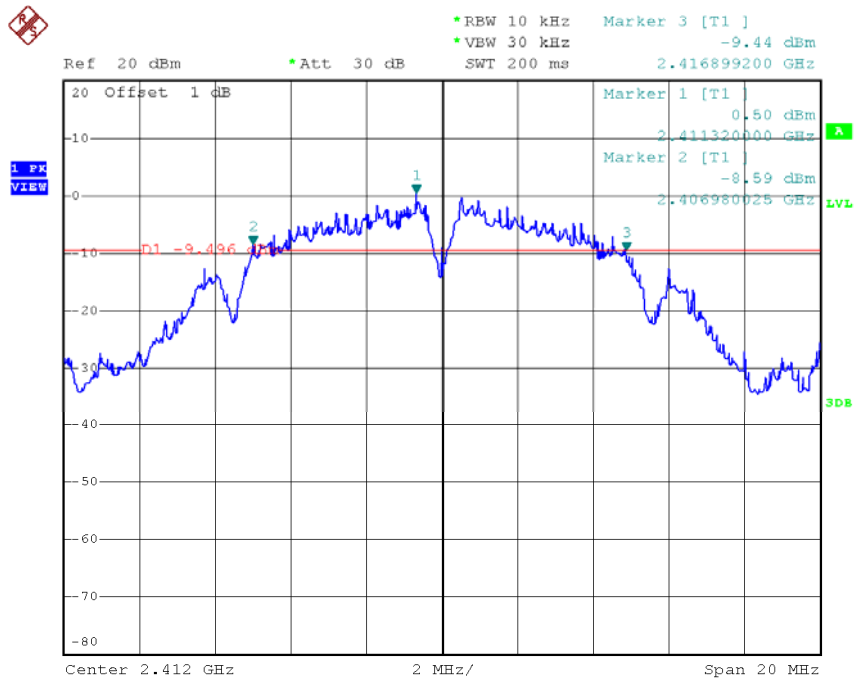

Date: 12.NOV.2015 17:20:02

Low Voltage CH07

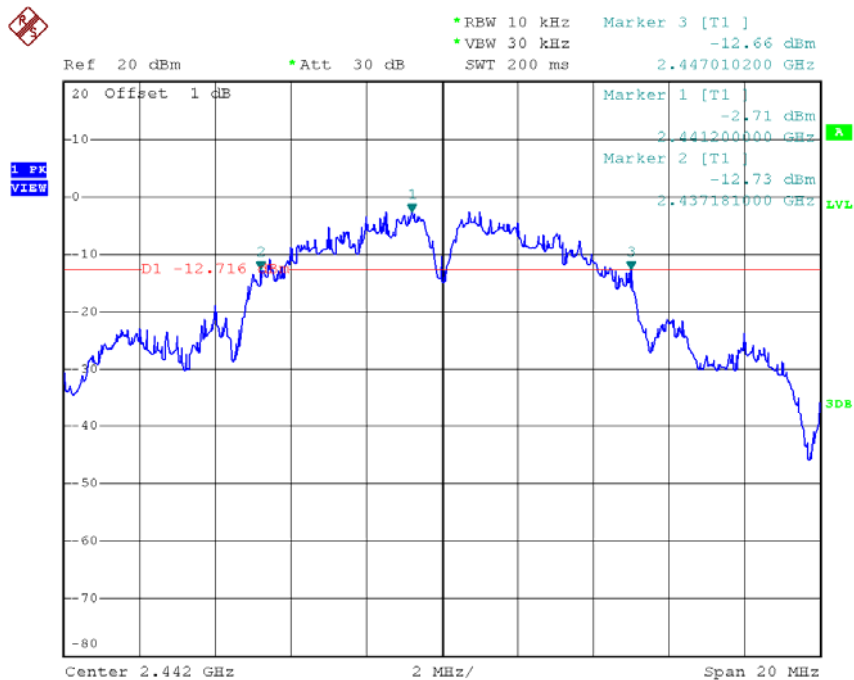

Date: 14.NOV.2015 15:48:28

Low Voltage CH13

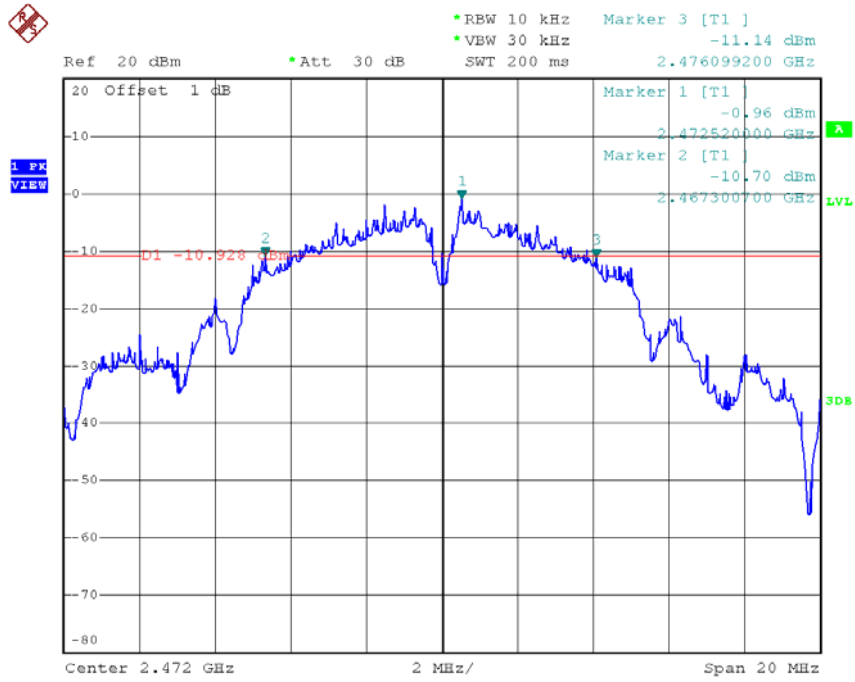

Date: 14.NOV.2015 16:26:30

Test Mode:	802.11g/CH01,CH07,CH13
------------	------------------------

Test Voltage (V)	Normal Voltage			Remarks
Test Frequency (MHz)	2412	2442	2472	Low/Mid/High of test frequency range
Measured Frequency (MHz)	2411.9950	2441.9950	2471.9800	-
Frequency Tolerance (ppm)	-2.07	-2.05	-8.10	Limit \cong 50 ppm

Test Voltage (V)	High Voltage			Remarks
Test Frequency (MHz)	2412	2442	2472	Low/Mid/High of test frequency range
Measured Frequency (MHz)	2411.9799	2441.9950	2471.9799	-
Frequency Tolerance (ppm)	-8.33	-2.05	-8.13	Limit \cong 50 ppm

Test Voltage (V)	Low Voltage			Remarks
Test Frequency (MHz)	2412	2442	2472	Low/Mid/High of test frequency range
Measured Frequency (MHz)	2412.0150	2442.0150	2471.9999	-
Frequency Tolerance (ppm)	6.22	6.14	-0.04	Limit \cong 50 ppm

High Voltage CH07

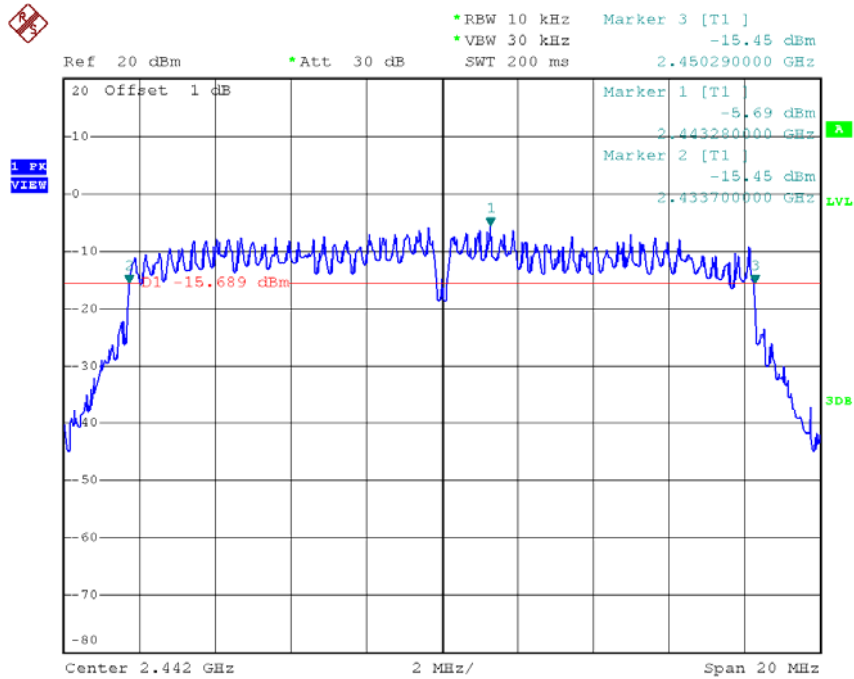

Date: 13.NOV.2015 18:47:07

High Voltage CH13

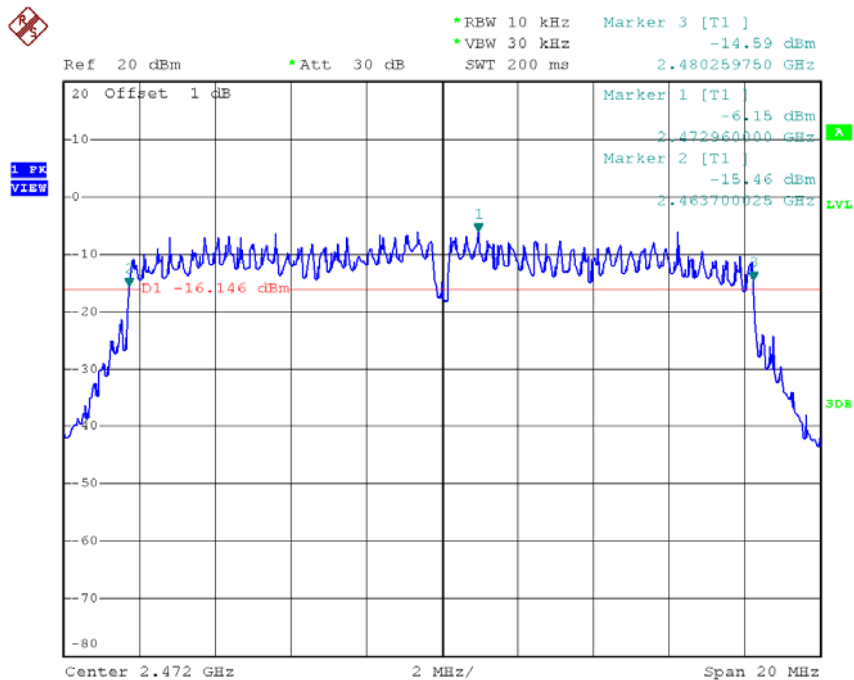

Date: 13.NOV.2015 19:07:21

Low Voltage CH01

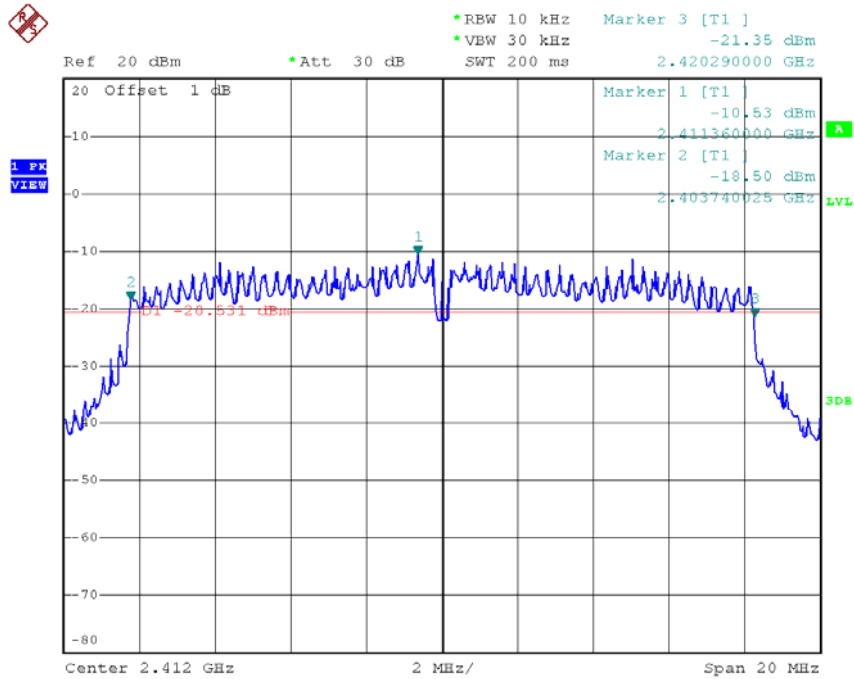

Date: 13.NOV.2015 18:36:28

Low Voltage CH07

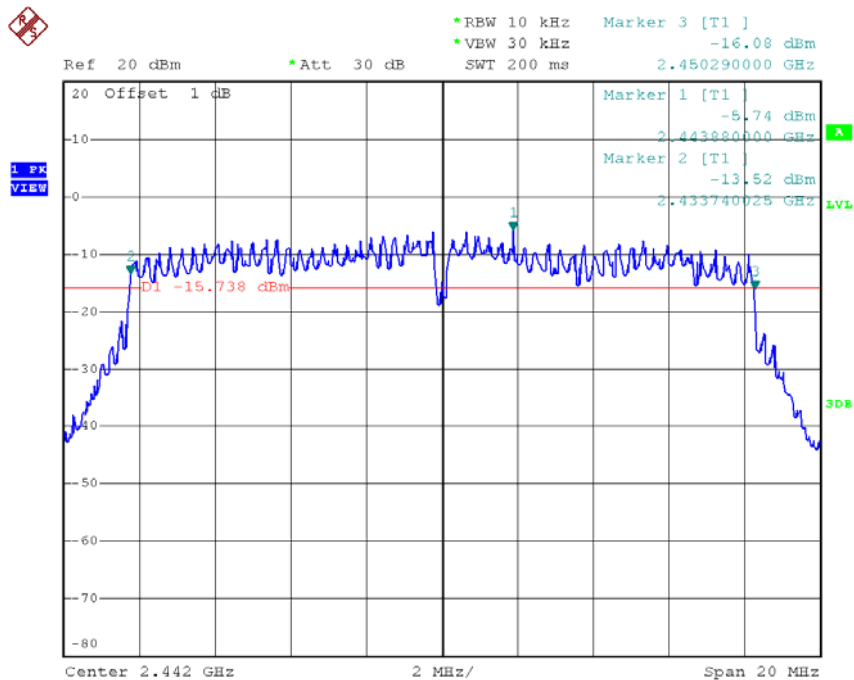

Date: 13.NOV.2015 18:53:51

Low Voltage CH13

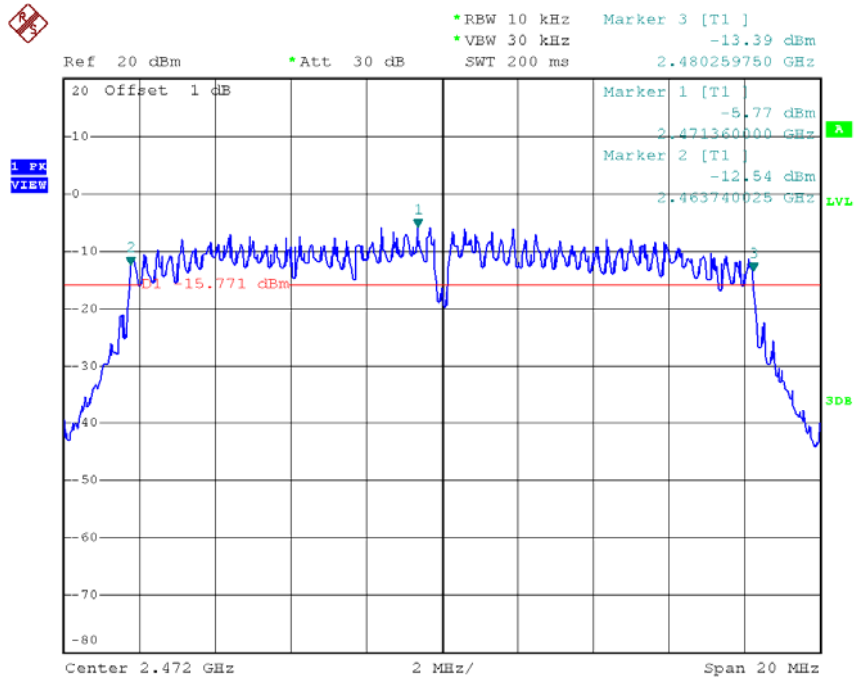

Date: 13.NOV.2015 19:13:27

Test Mode:	802.11n(HT20)/CH01,CH07,CH13
------------	------------------------------

Test Voltage (V)	Normal Voltage			Remarks
Test Frequency (MHz)	2412	2442	2472	Low/Mid/High of test frequency range
Measured Frequency (MHz)	2412.0000	2441.9799	2471.9950	-
Frequency Tolerance (ppm)	-0.01	-8.24	-2.02	Limit \cong 50 ppm

Test Voltage (V)	High Voltage			Remarks
Test Frequency (MHz)	2412	2442	2472	Low/Mid/High of test frequency range
Measured Frequency (MHz)	2411.9950	2441.9950	2472.0000	-
Frequency Tolerance (ppm)	-2.07	-2.05	-0.01	Limit \cong 50 ppm

Test Voltage (V)	Low Voltage			Remarks
Test Frequency (MHz)	2412	2442	2472	Low/Mid/High of test frequency range
Measured Frequency (MHz)	2411.9951	2442.0000	2472.0000	-
Frequency Tolerance (ppm)	-2.03	-0.01	-0.01	Limit \cong 50 ppm

Normal Voltage CH01

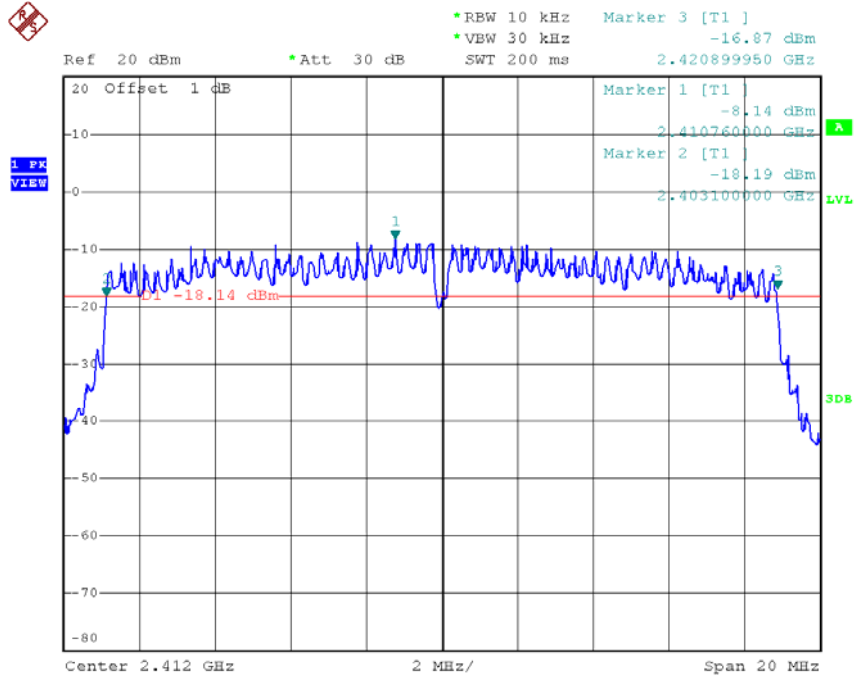

Date: 14.NOV.2015 13:08:55

Normal Voltage CH07

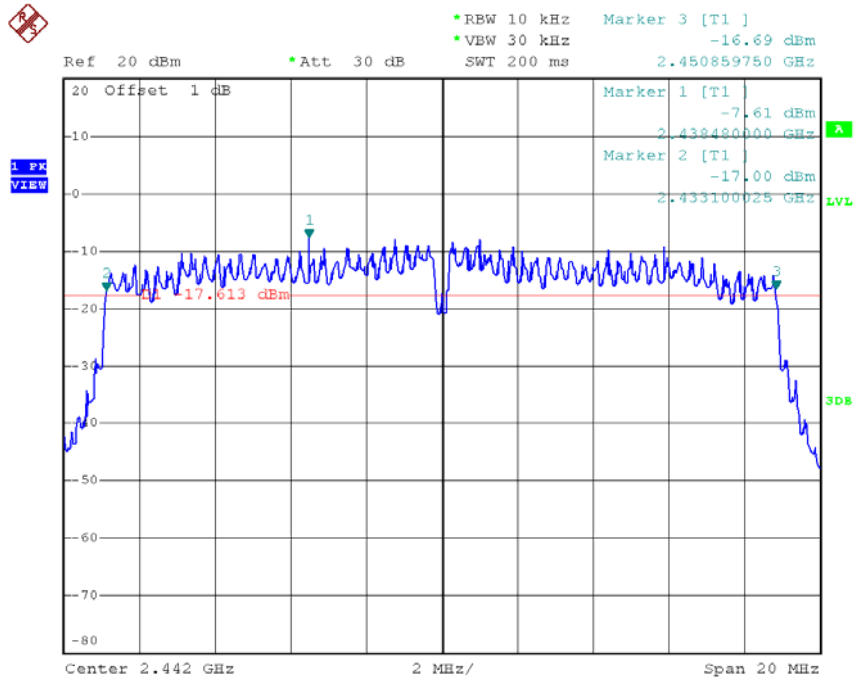

Date: 14.NOV.2015 13:33:27

Normal Voltage CH13

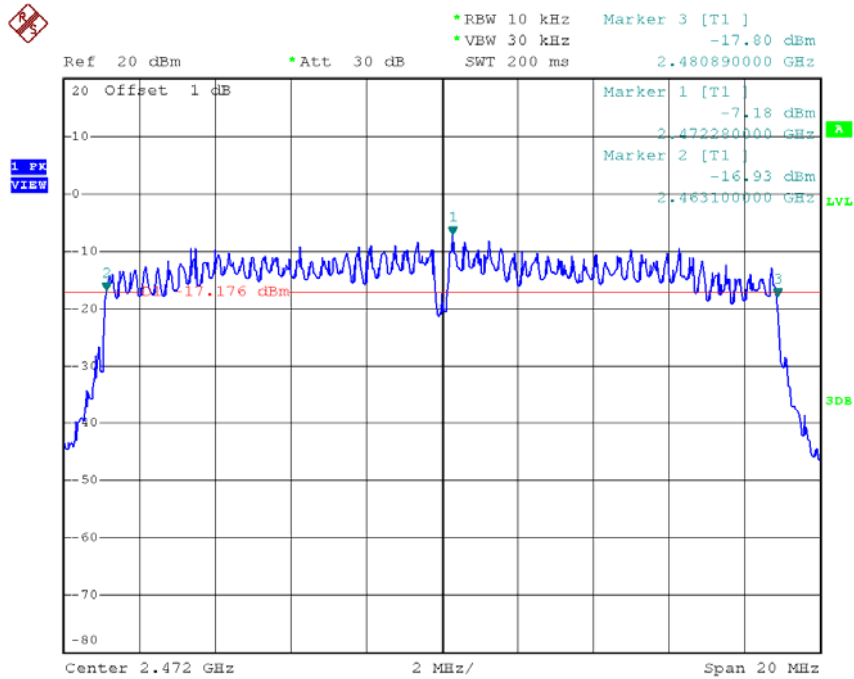

Date: 14.NOV.2015 13:47:43

High Voltage CH01

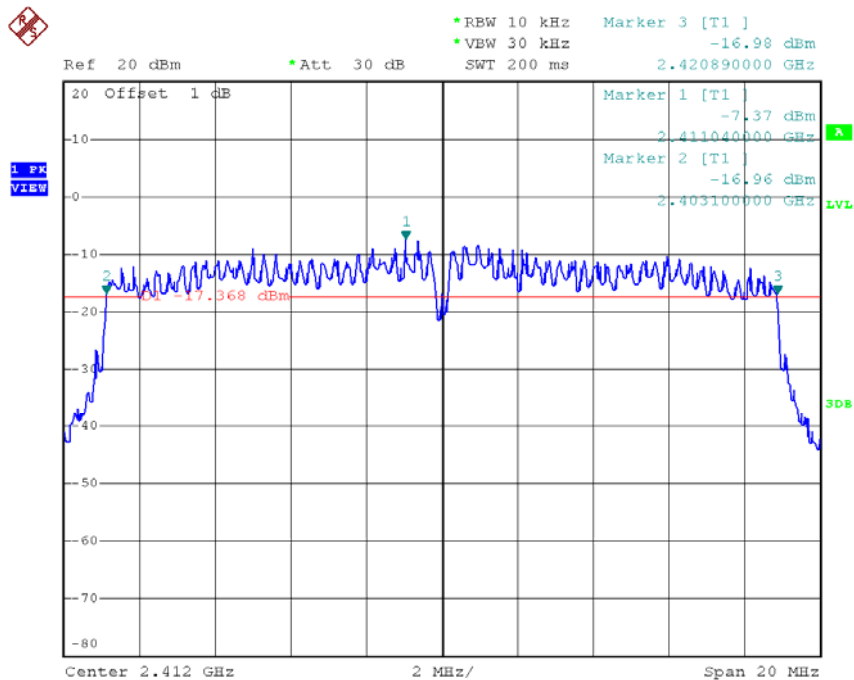

Date: 14.NOV.2015 13:02:53

High Voltage CH07

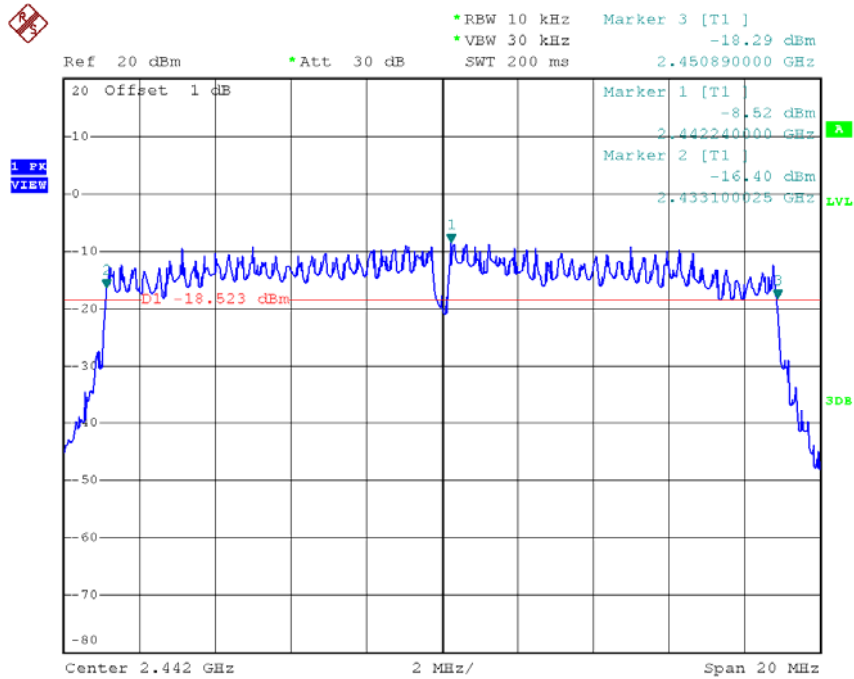

Date: 14.NOV.2015 13:30:05

High Voltage CH13

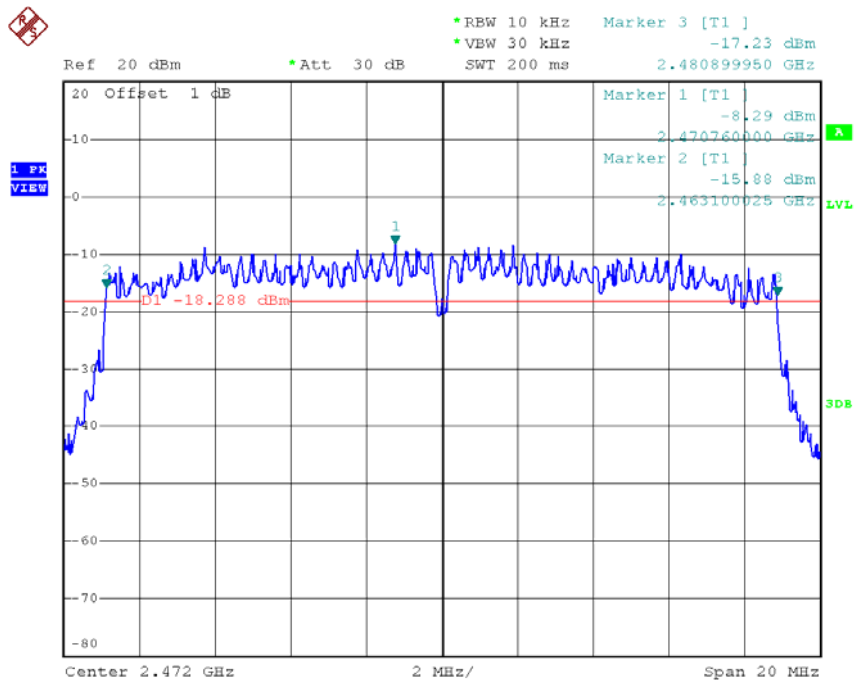

Date: 14.NOV.2015 13:44:58

Low Voltage CH01

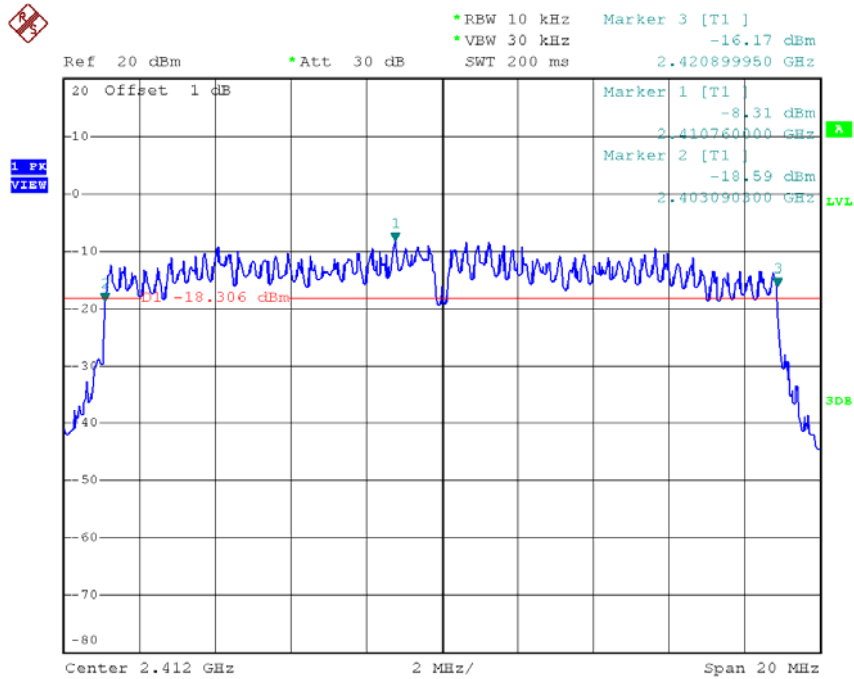

Date: 14.NOV.2015 13:16:45

Low Voltage CH07

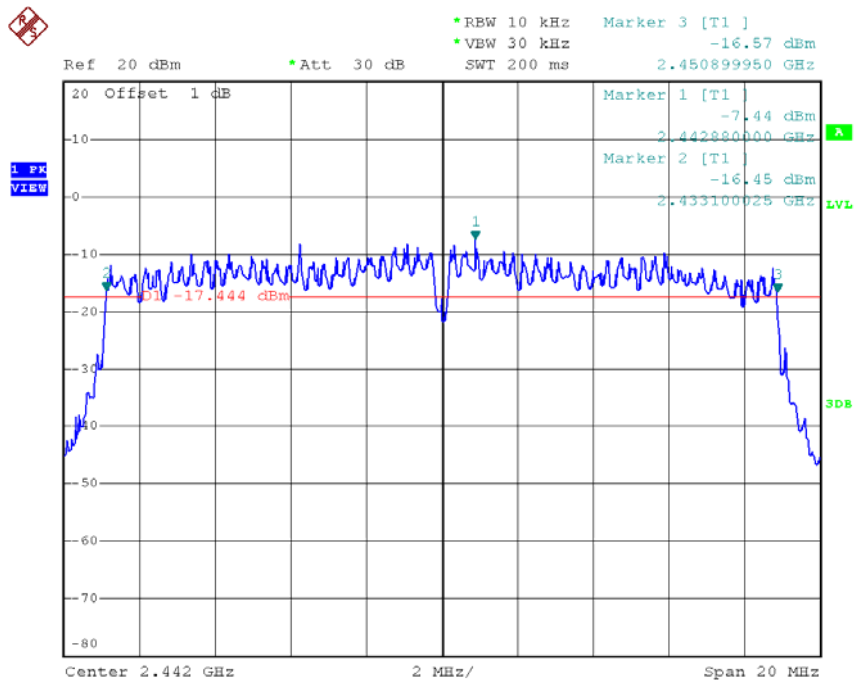

Date: 14.NOV.2015 13:36:46

Low Voltage
CH13

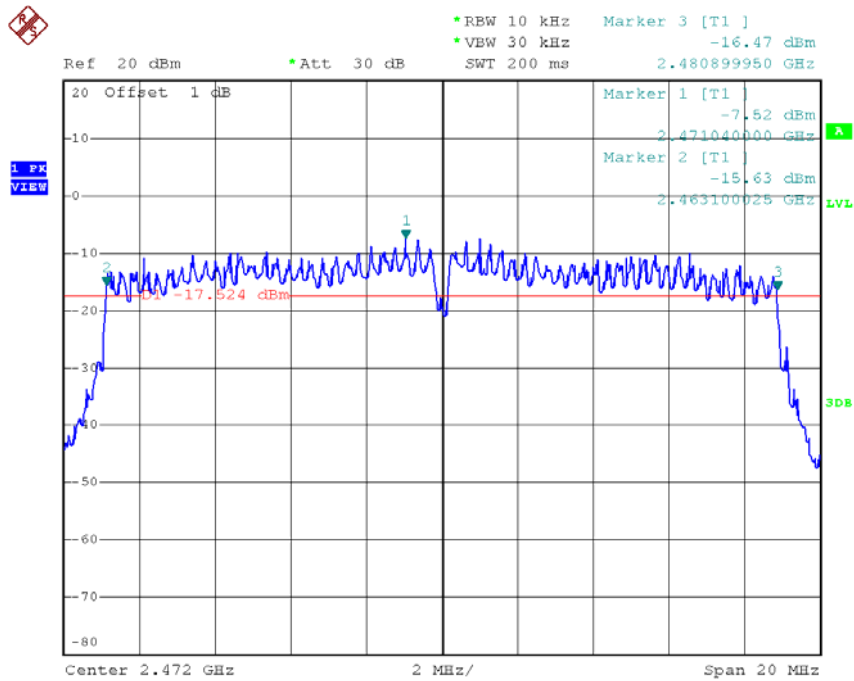

Date: 14.NOV.2015 14:00:29

**ATTACHMENT B - OCCUPIED BANDWIDTH AND
SPREAD-SPECTRUM BANDWIDTH**

For Chip antenna

Test Mode:	802.11b/CH01,CH07,CH13
------------	------------------------

Test Voltage (V)	Normal Voltage			Remarks
Test Frequency (MHz)	2412	2442	2472	Low/Mid/High of test frequency range
Occupied bandwidth (MHz)	13.60	12.10	11.30	Limit \leq 26 MHz (RBW/VBW : 300kHz)
Spreading Bandwidth (MHz)	7.80	7.50	7.50	\geq 500 kHz (FHSS, DSSS)
Spread-factor=Spreading Bandwidth/1.375	5.67	5.45	5.45	Spread Factor Limit \geq 5 (DSSS and FHSS)

Test Voltage (V)	High Voltage			Remarks
Test Frequency (MHz)	2412	2442	2472	Low/Mid/High of test frequency range
Occupied bandwidth (MHz)	13.50	12.20	11.30	Limit \leq 26 MHz (RBW/VBW : 300kHz)
Spreading Bandwidth (MHz)	7.80	7.50	7.50	\geq 500 kHz (FHSS, DSSS)
Spread-factor=Spreading Bandwidth/1.375	5.67	5.45	5.45	Spread Factor Limit \geq 5 (DSSS and FHSS)

Test Voltage (V)	Low Voltage			Remarks
Test Frequency (MHz)	2412	2442	2472	Low/Mid/High of test frequency range
Occupied bandwidth (MHz)	13.50	12.10	11.30	Limit \leq 26 MHz (RBW/VBW : 300kHz)
Spreading Bandwidth (MHz)	7.80	7.50	7.50	\geq 500 kHz (FHSS, DSSS)
Spread-factor=Spreading Bandwidth/1.375	5.67	5.45	5.45	Spread Factor Limit \geq 5 (DSSS and FHSS)

Note: 1. Spread Factor = Spread Bandwidth / TR

(TR = 1.375 for 802.11b; TR = 1.5 for 802.11g / 802.11n (20M); TR = 3 for 802.11n (40M))

Normal Voltage CH01 -99 % OBW

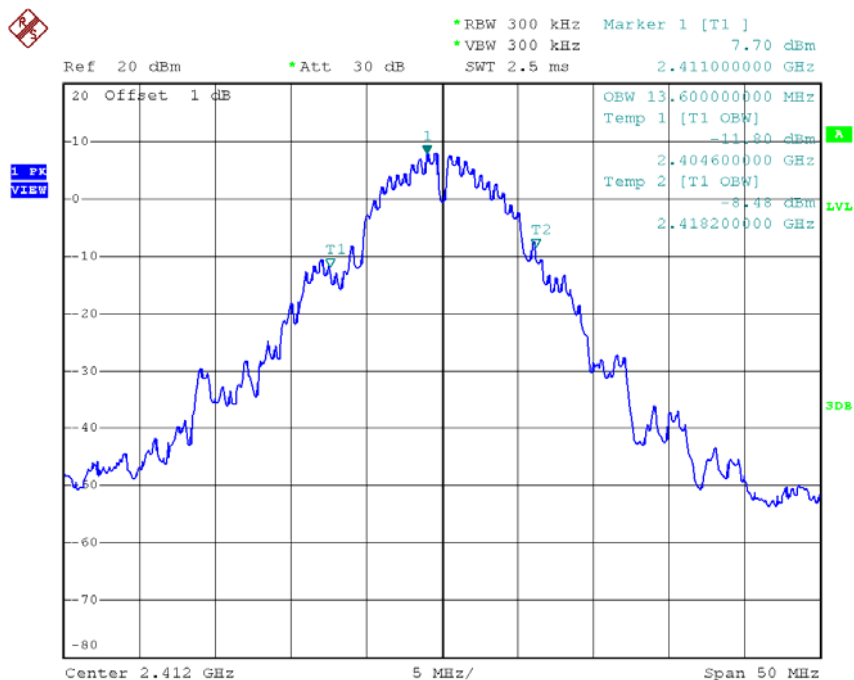

Date: 14.NOV.2015 15:30:00

Normal Voltage CH01 -90 % OBW

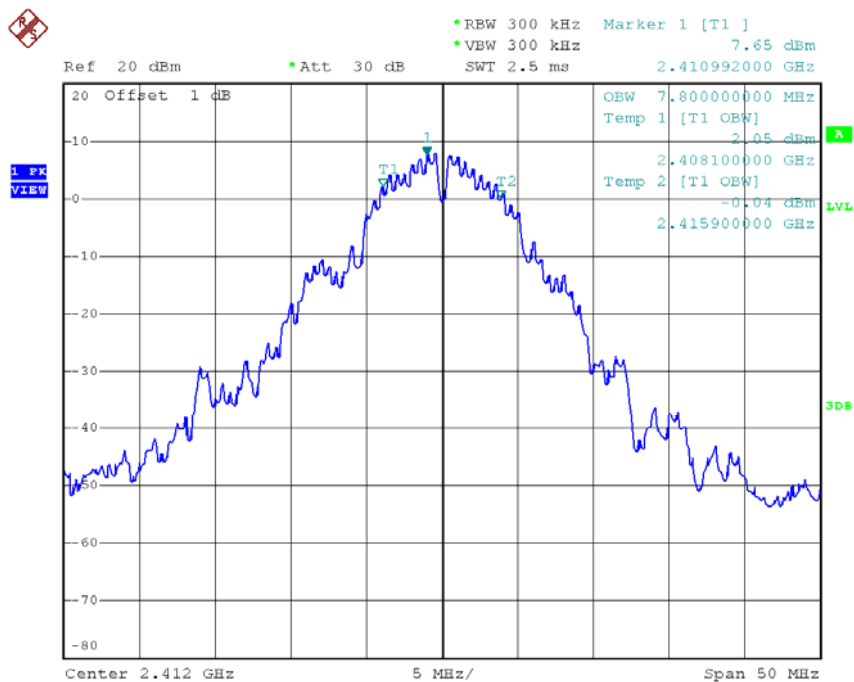

Date: 14.NOV.2015 15:29:53

Normal Voltage CH07 -99 % OBW

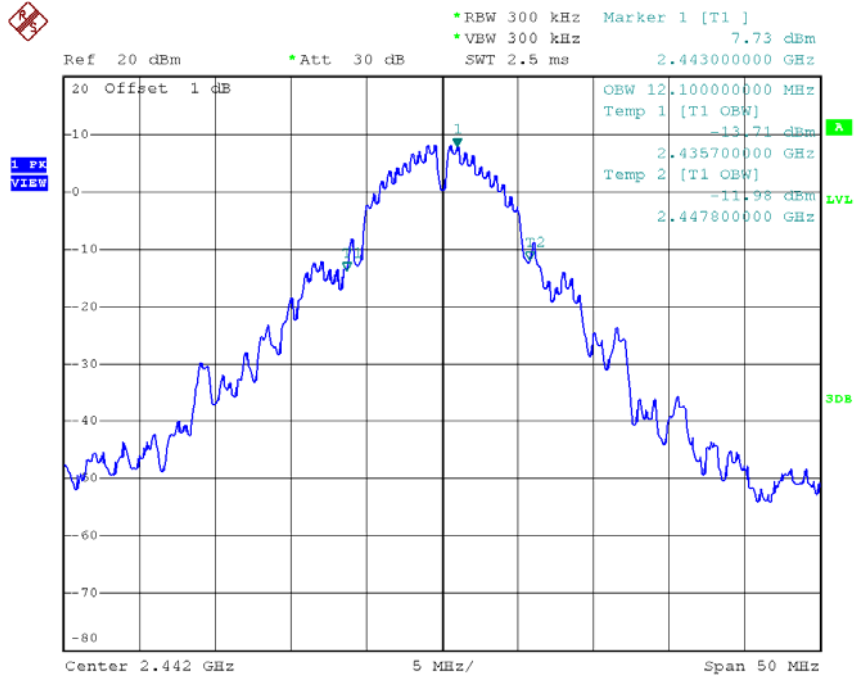

Date: 14.NOV.2015 15:42:28

Normal Voltage CH07 -90 % OBW

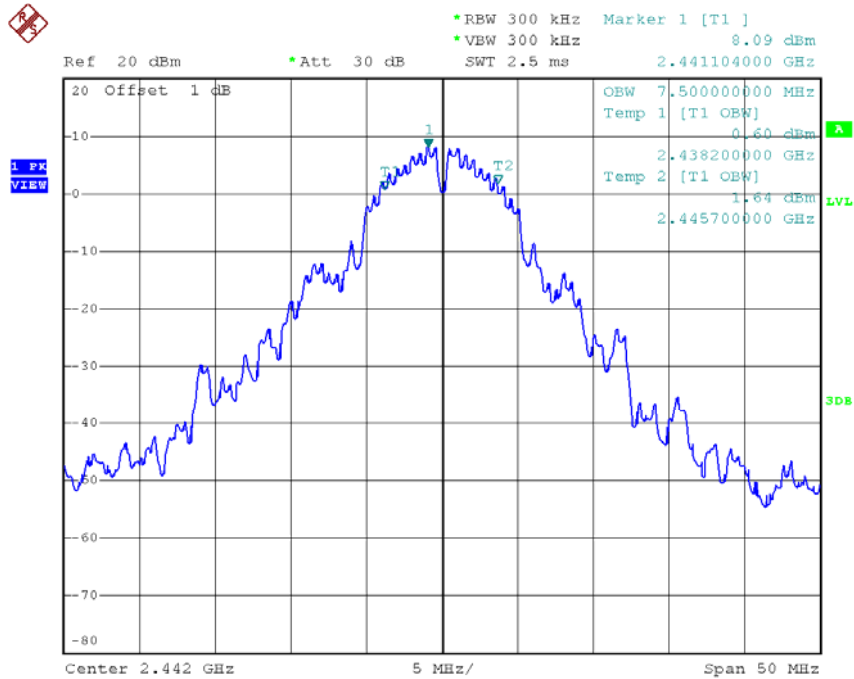

Date: 14.NOV.2015 15:42:20

Normal Voltage CH13 -99 % OBW

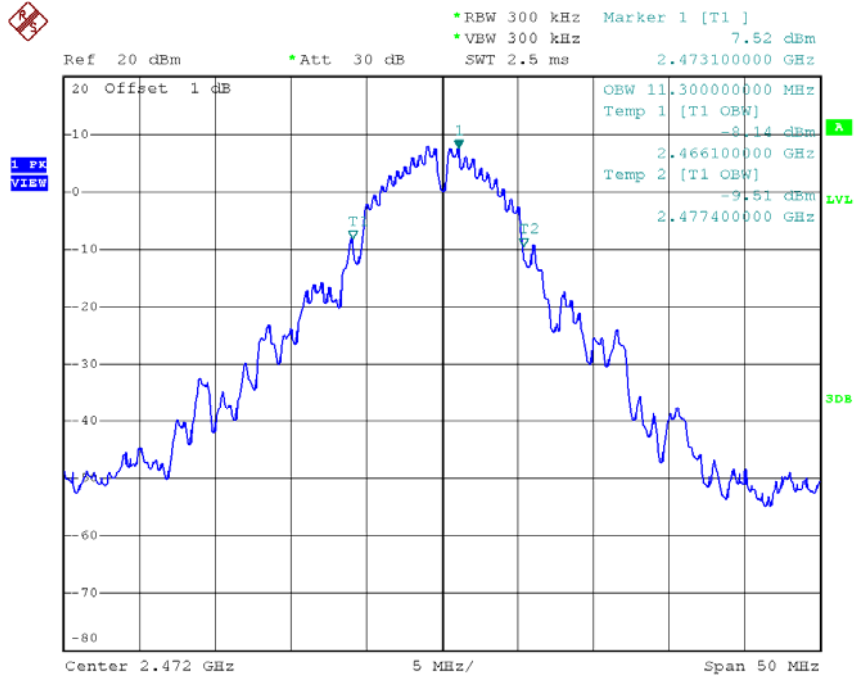

Date: 14.NOV.2015 16:19:11

Normal Voltage CH13 -90 % OBW

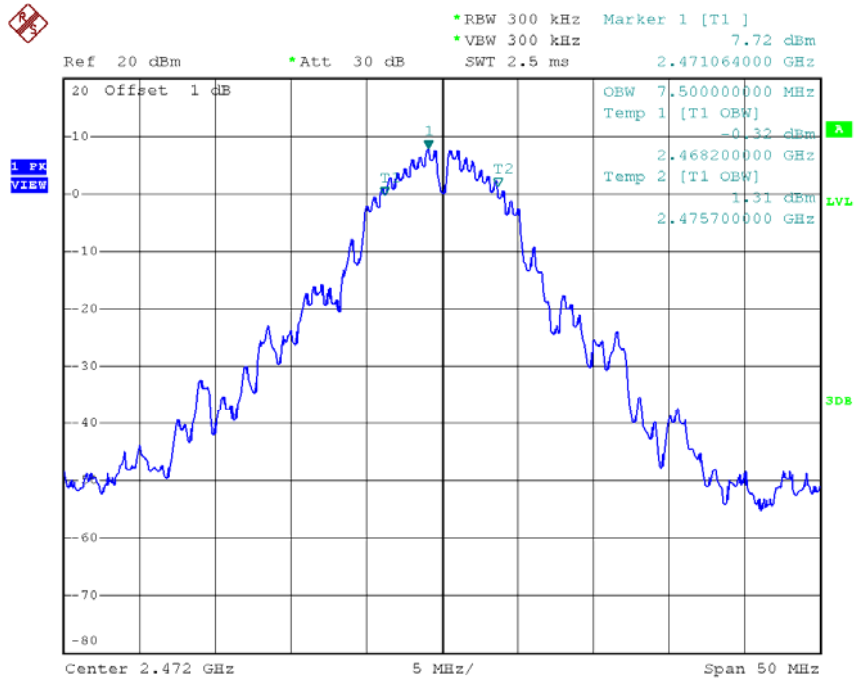

Date: 14.NOV.2015 16:19:03

High Voltage CH01 -99 % OBW

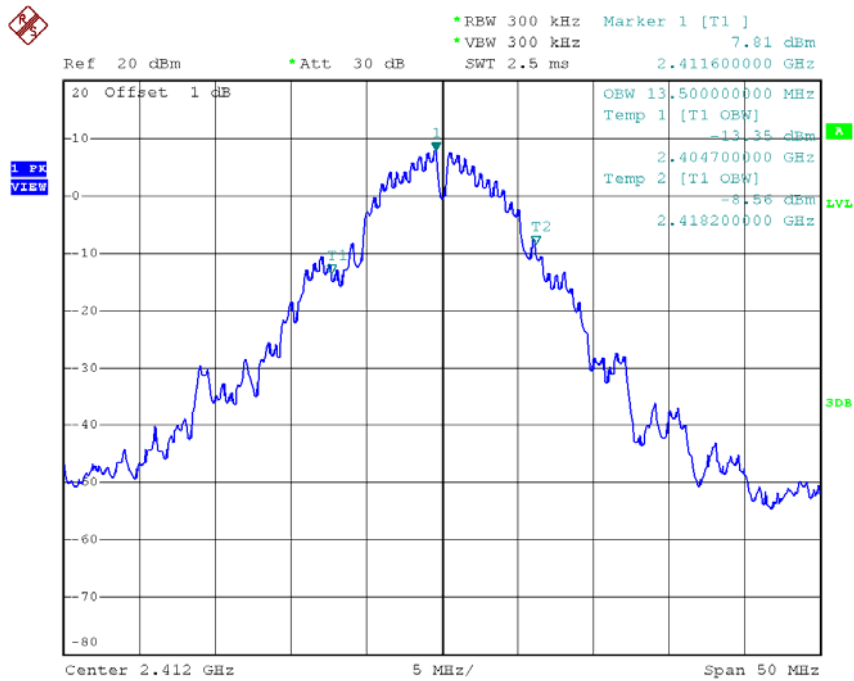

Date: 14.NOV.2015 15:27:40

High Voltage CH01 -90 % OBW

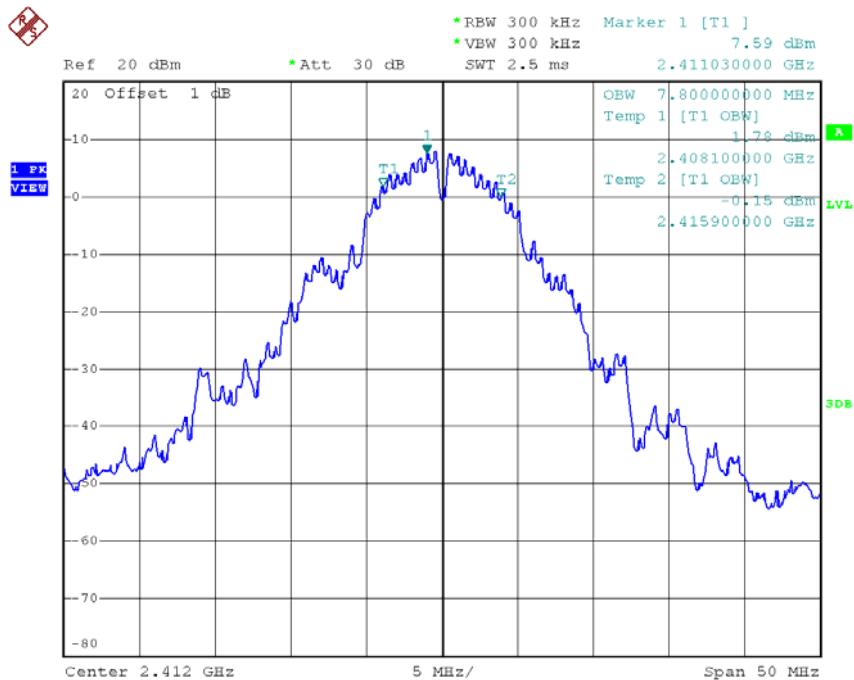

Date: 14.NOV.2015 15:27:33

High Voltage CH07 -99 % OBW

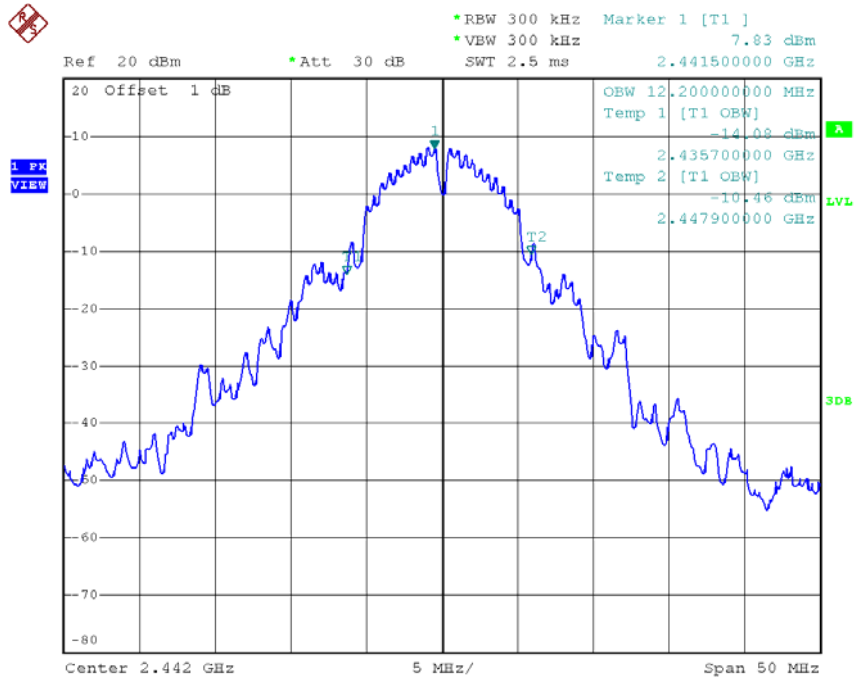

Date: 14.NOV.2015 15:39:15

High Voltage CH07 -90 % OBW

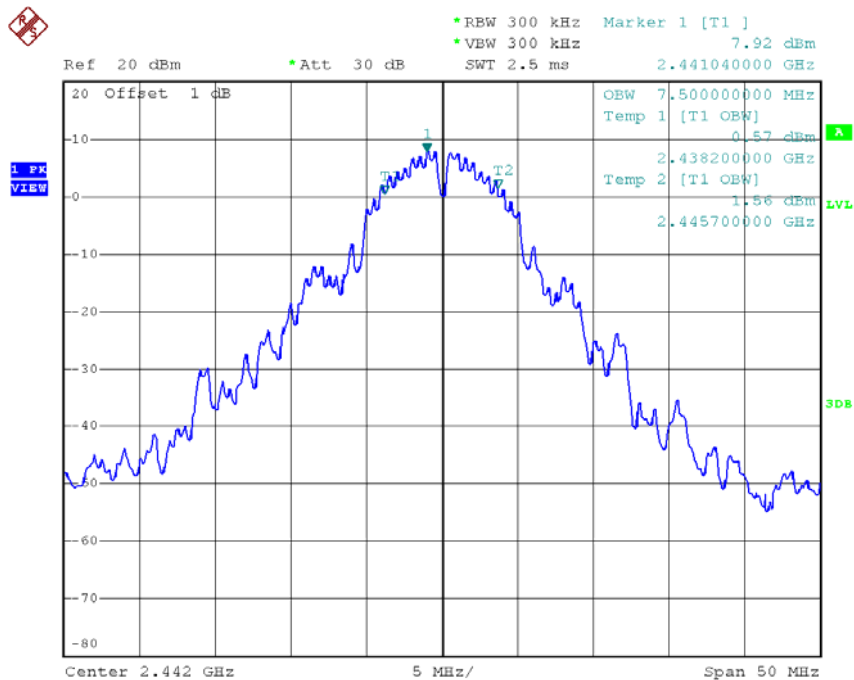

Date: 14.NOV.2015 15:39:07

High Voltage CH13 -99 % OBW

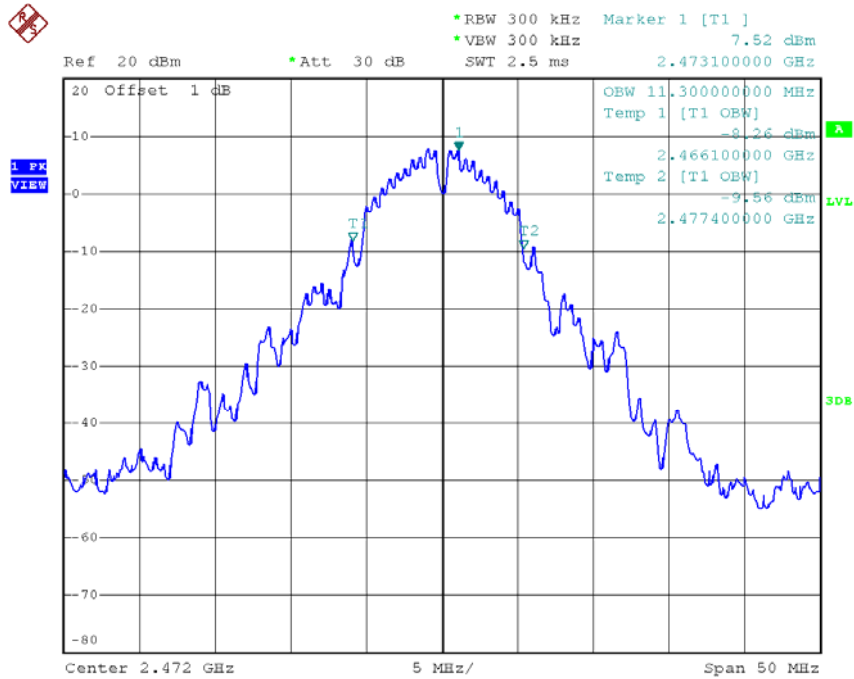

Date: 14.NOV.2015 16:15:08

High Voltage CH13 -90 % OBW

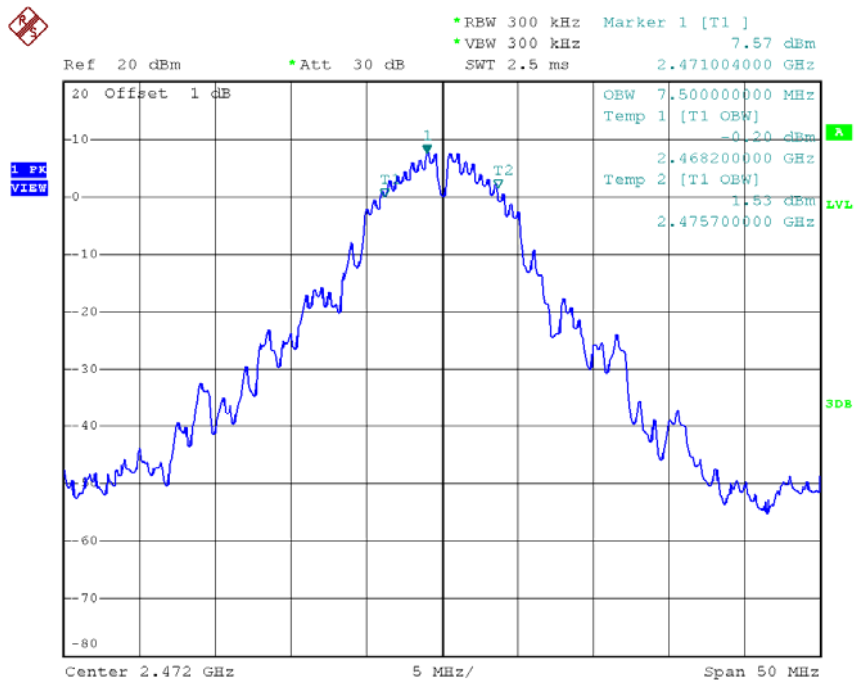

Date: 14.NOV.2015 16:15:00

Low Voltage CH01 -99 % OBW

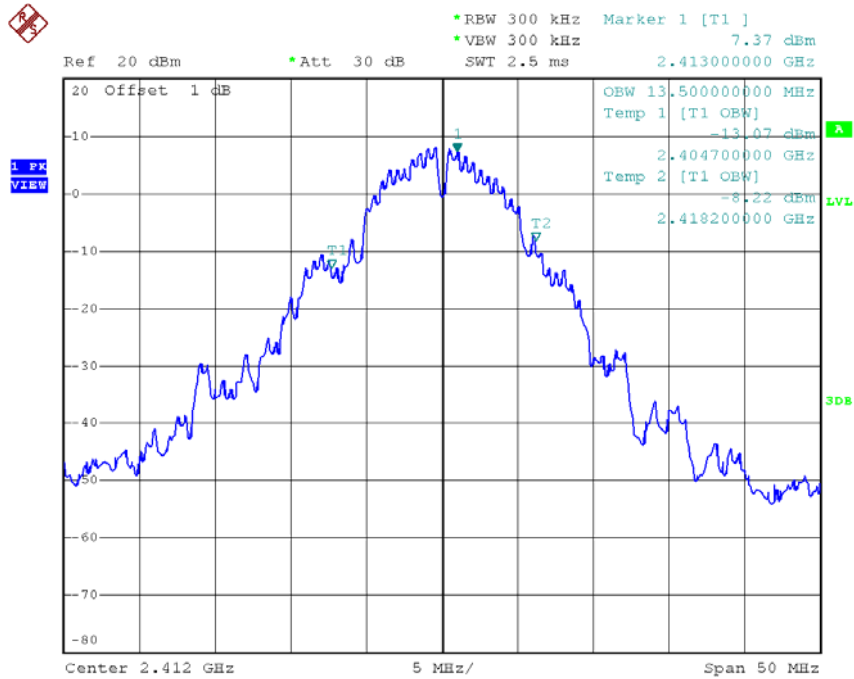

Date: 14.NOV.2015 15:33:52

Low Voltage CH01 -90 % OBW

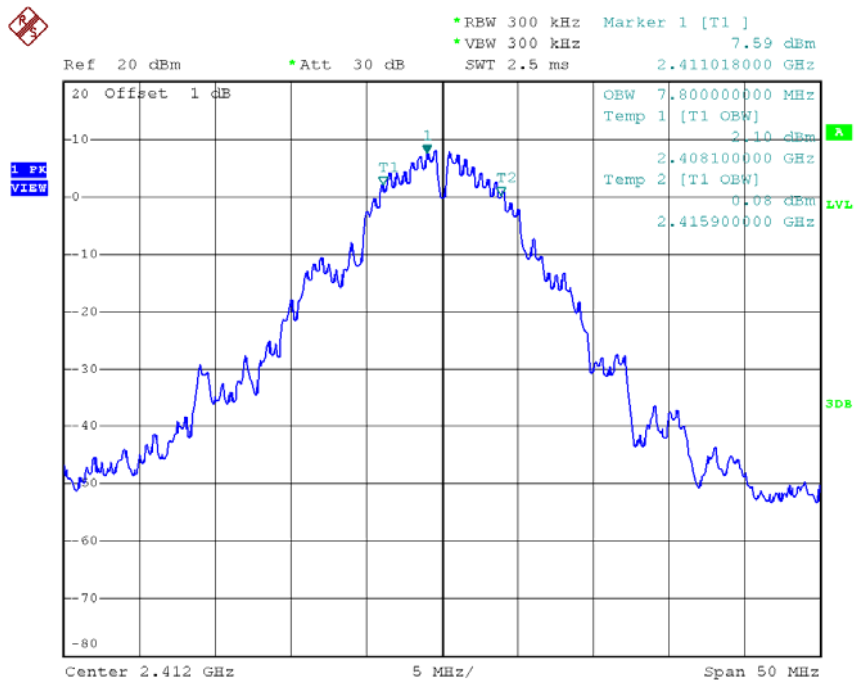

Date: 14.NOV.2015 15:33:45

Low Voltage CH07 -99 % OBW

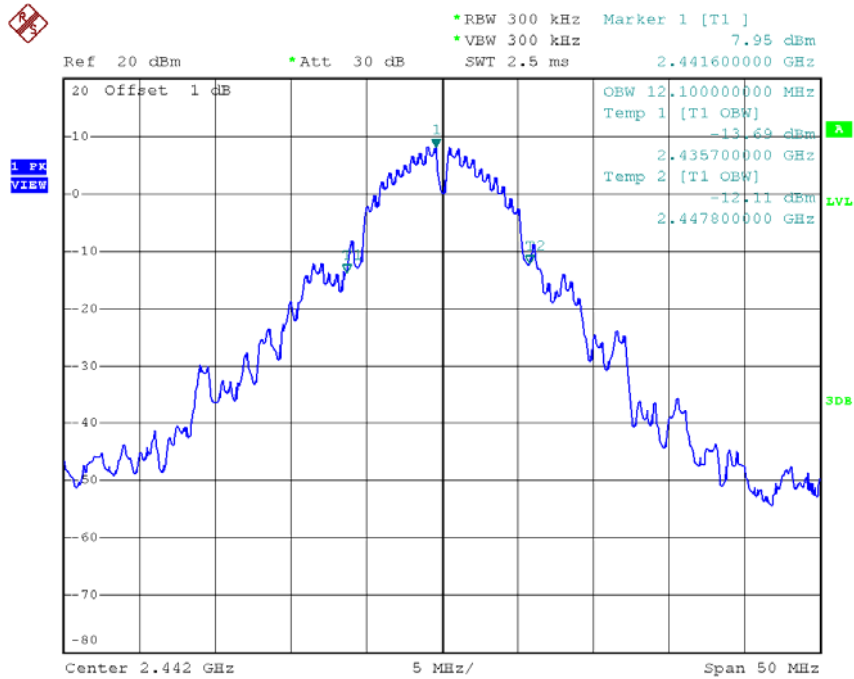

Date: 14.NOV.2015 15:47:16

Low Voltage CH07 -90 % OBW

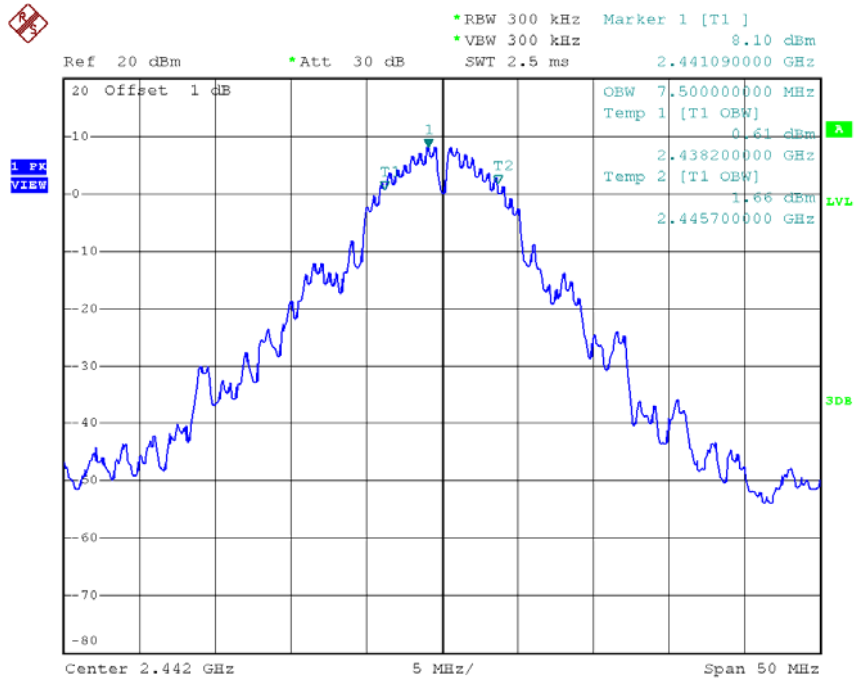

Date: 14.NOV.2015 15:47:08

Low Voltage CH13 -99 % OBW

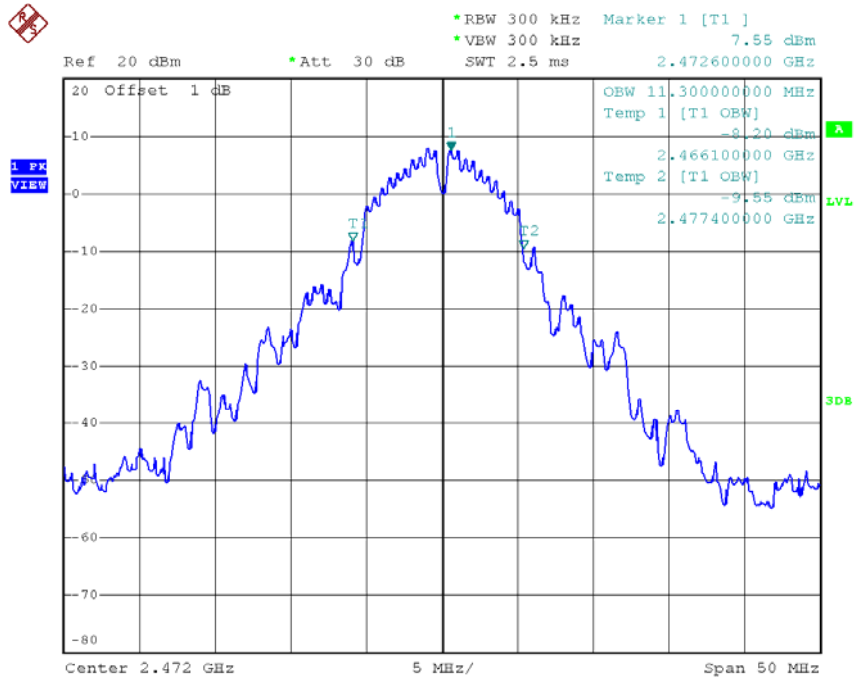

Date: 14.NOV.2015 16:24:59

Low Voltage CH13 -90 % OBW

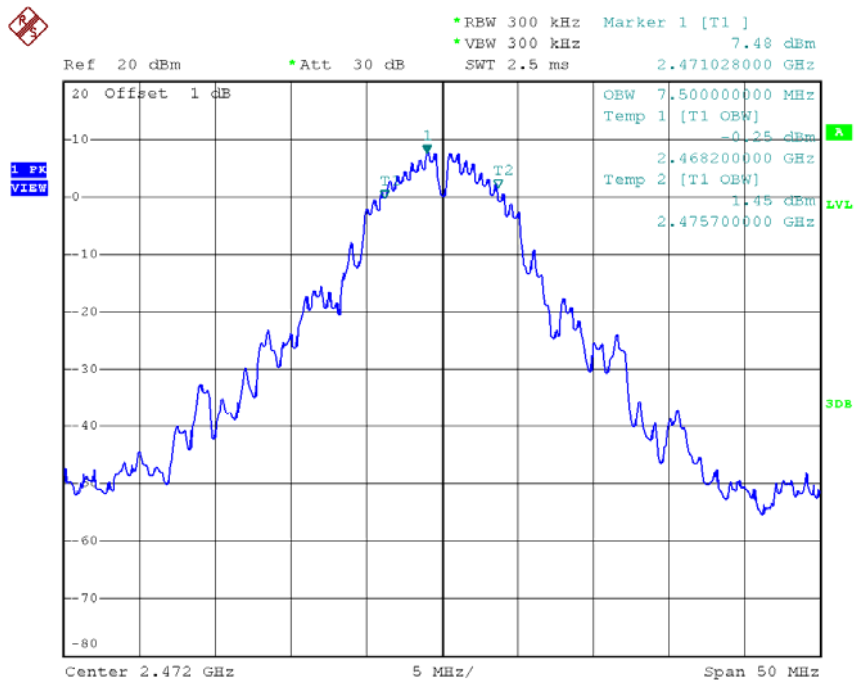

Date: 14.NOV.2015 16:24:51

Test Mode:	802.11g/CH01,CH07,CH13
------------	------------------------

Test Voltage (V)	Normal Voltage			Remarks
Test Frequency (MHz)	2412	2442	2472	Low/Mid/High of test frequency range
Occupied bandwidth (MHz)	17.60	23.00	17.90	Limit \leq 26 MHz (RBW/VBW : 300kHz)
Spreading Bandwidth (MHz)	14.90	15.10	14.60	\geq 500 kHz (FHSS, DSSS)
Spread-factor=Spreading Bandwidth/1.5	9.93	10.07	9.73	Spread Factor Limit \geq 5 (DSSS and FHSS)

Test Voltage (V)	High Voltage			Remarks
Test Frequency (MHz)	2412	2442	2472	Low/Mid/High of test frequency range
Occupied bandwidth (MHz)	17.60	23.10	17.80	Limit \leq 26 MHz (RBW/VBW : 300kHz)
Spreading Bandwidth (MHz)	14.80	15.00	14.80	\geq 500 kHz (FHSS, DSSS)
Spread-factor=Spreading Bandwidth/1.5	9.87	10.00	9.87	Spread Factor Limit \geq 5 (DSSS and FHSS)

Test Voltage (V)	Low Voltage			Remarks
Test Frequency (MHz)	2412	2442	2472	Low/Mid/High of test frequency range
Occupied bandwidth (MHz)	17.60	23.00	17.80	Limit \leq 26 MHz (RBW/VBW : 300kHz)
Spreading Bandwidth (MHz)	14.80	15.10	14.60	\geq 500 kHz (FHSS, DSSS)
Spread-factor=Spreading Bandwidth/1.5	9.87	10.07	9.73	Spread Factor Limit \geq 5 (DSSS and FHSS)

Note: 1. Spread Factor = Spread Bandwidth / TR

(TR = 1.375 for 802.11b; TR = 1.5 for 802.11g / 802.11n (20M); TR = 3 for 802.11n (40M))

Normal Voltage CH01 -99 % OBW

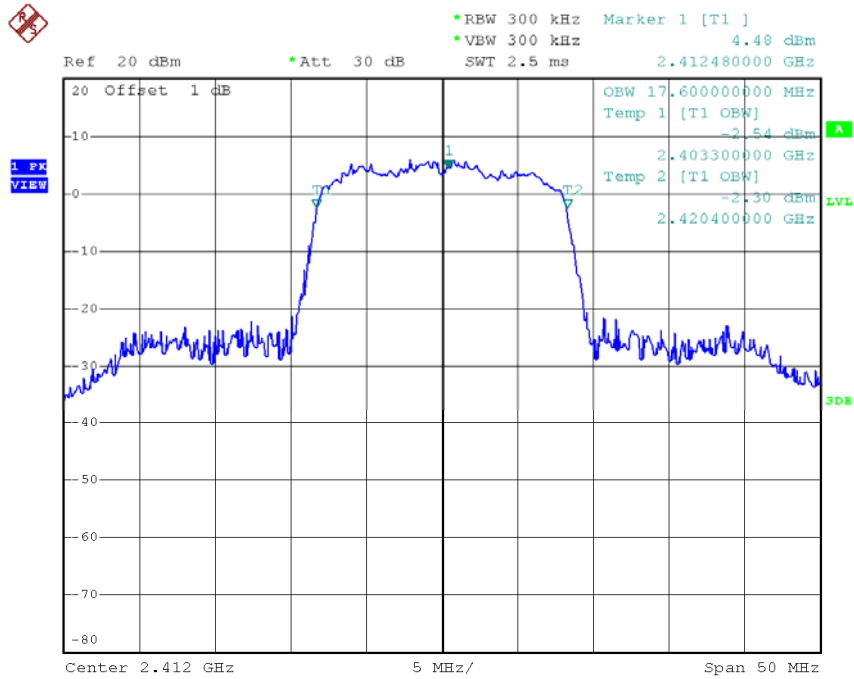

Date: 13.NOV.2015 18:12:27

Normal Voltage CH01 -90 % OBW

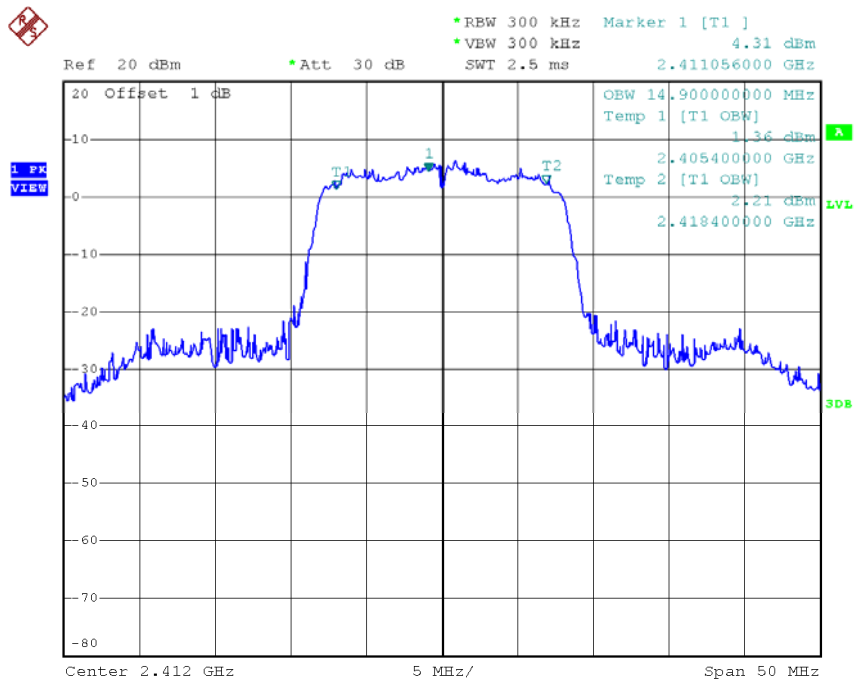

Date: 13.NOV.2015 18:19:59

Normal Voltage CH07 -99 % OBW

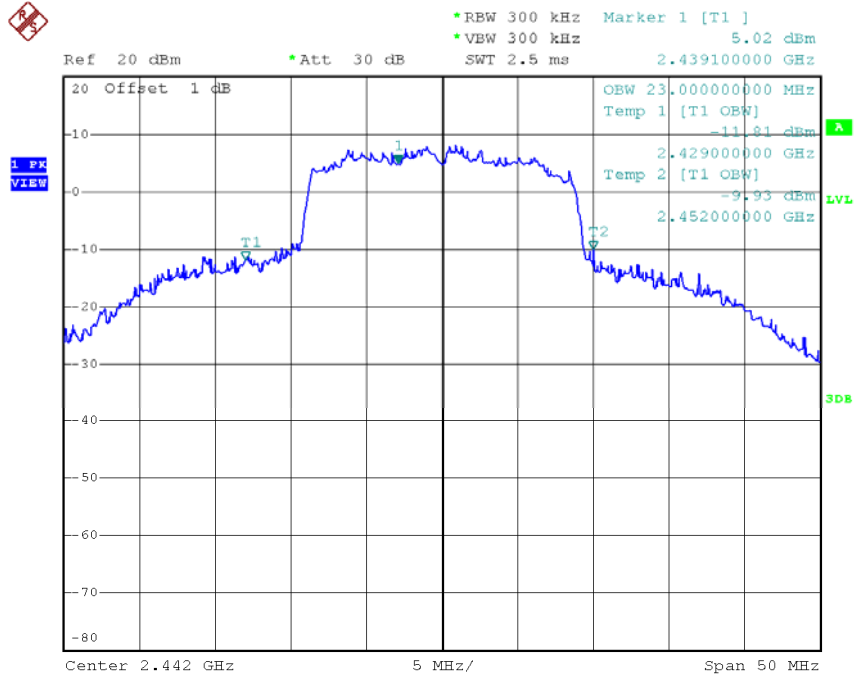

Date: 17.NOV.2015 16:13:02

Normal Voltage CH07 -90 % OBW

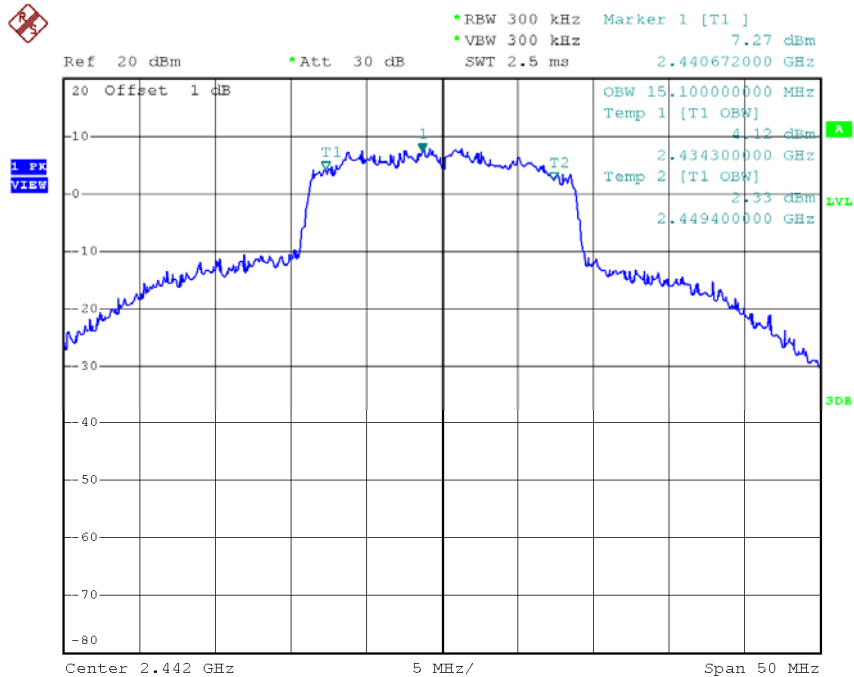

Date: 17.NOV.2015 16:12:55

Normal Voltage CH13 -99 % OBW

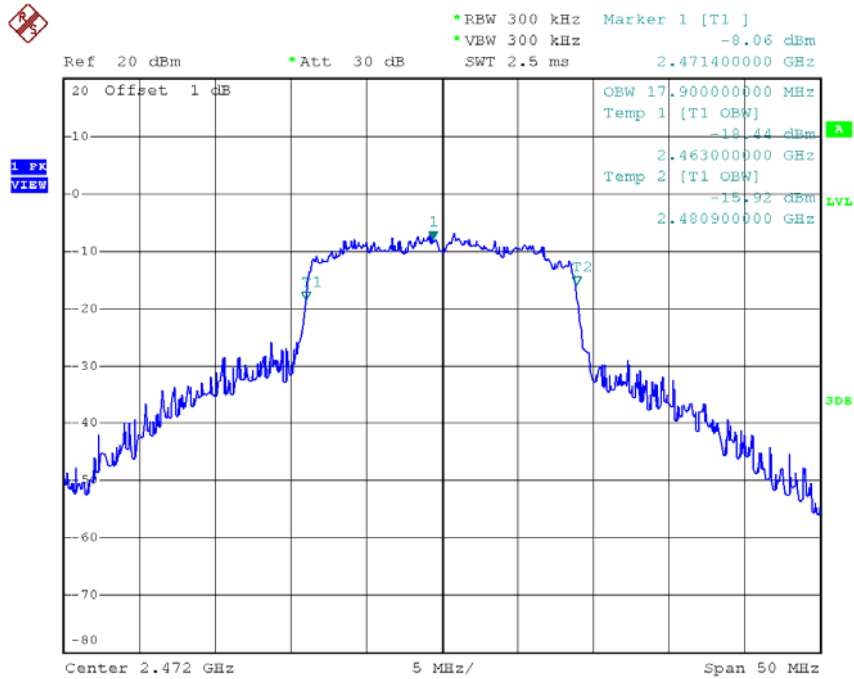

Date: 17.NOV.2015 16:26:10

Normal Voltage CH13 -90 % OBW

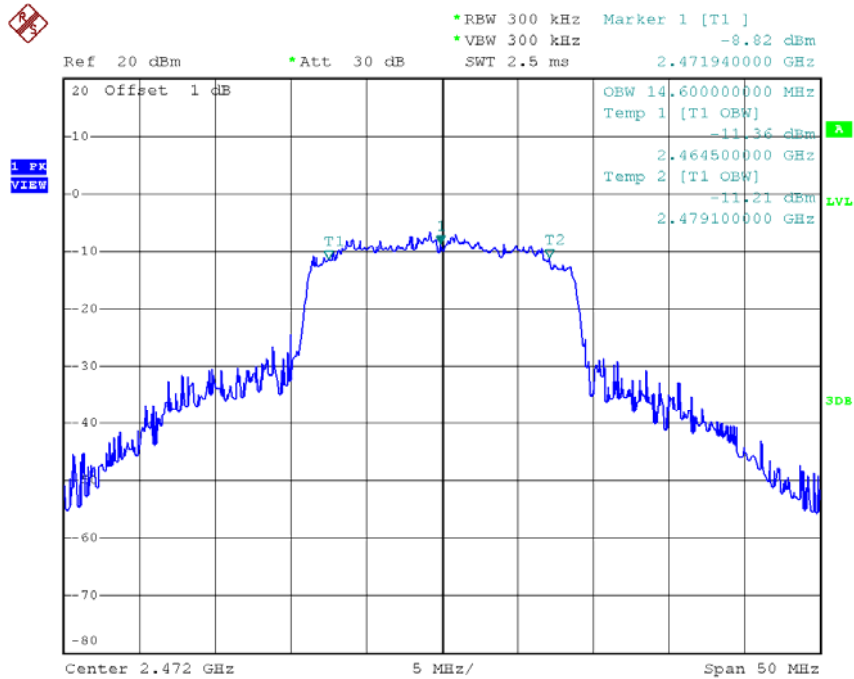

Date: 17.NOV.2015 16:26:02

High Voltage CH01 -99 % OBW

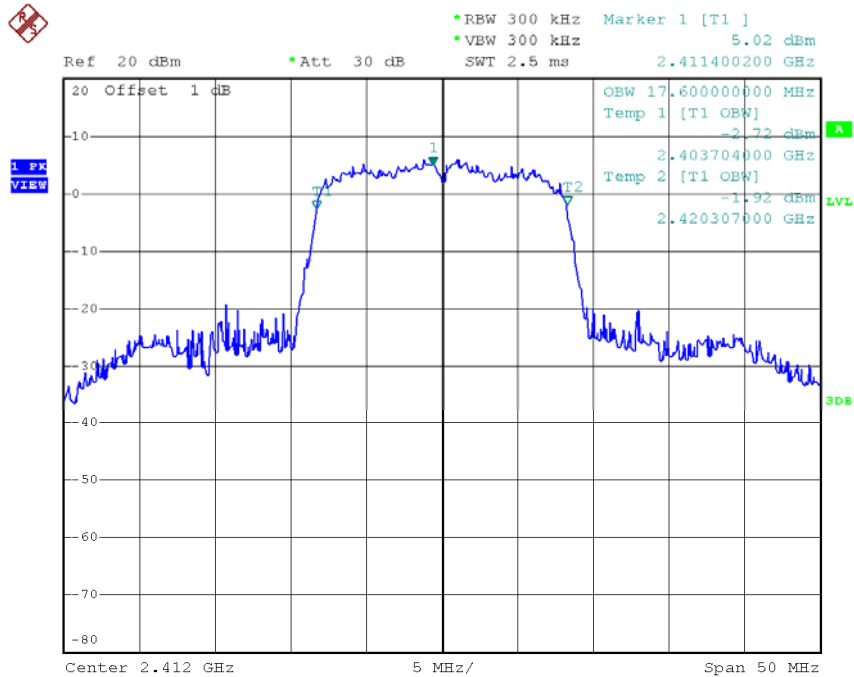

Date: 13.NOV.2015 18:17:46

High Voltage CH01 -90 % OBW

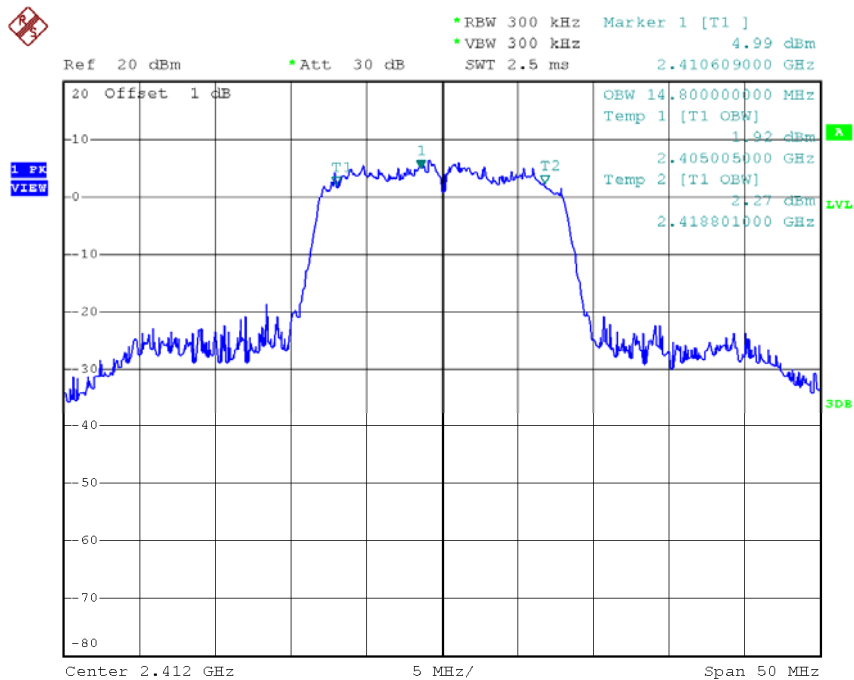

Date: 13.NOV.2015 18:17:38

High Voltage CH07 -99 % OBW

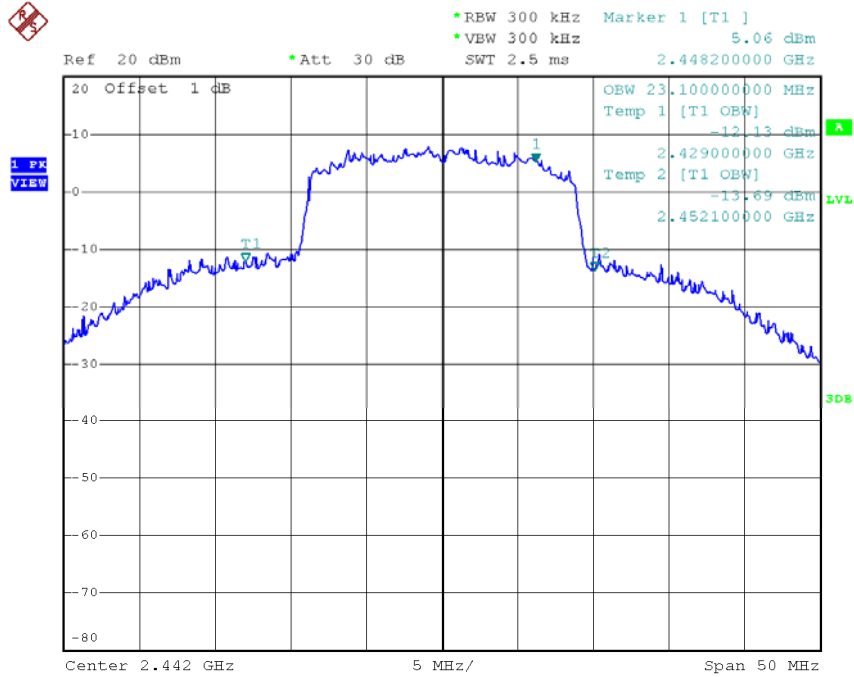

Date: 17.NOV.2015 16:10:18

High Voltage CH07 -90 % OBW

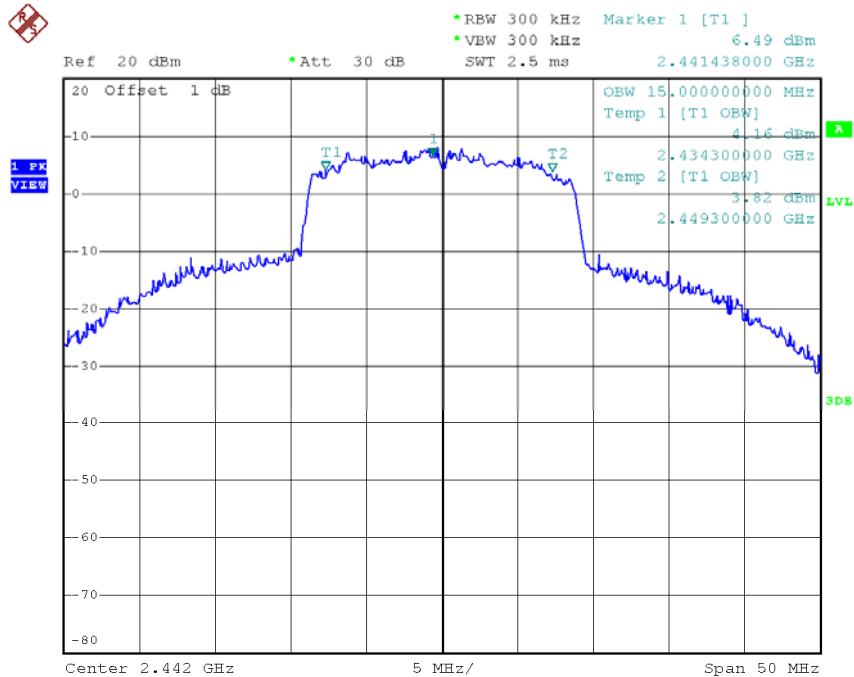

Date: 17.NOV.2015 16:10:10

High Voltage CH13 -99 % OBW

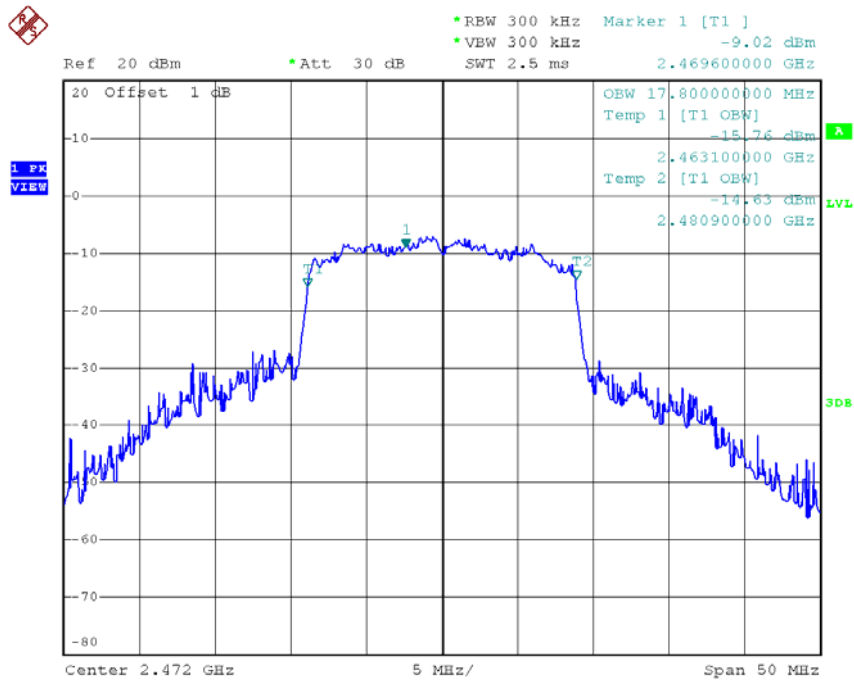

Date: 17.NOV.2015 16:23:33

High Voltage CH13 -90 % OBW

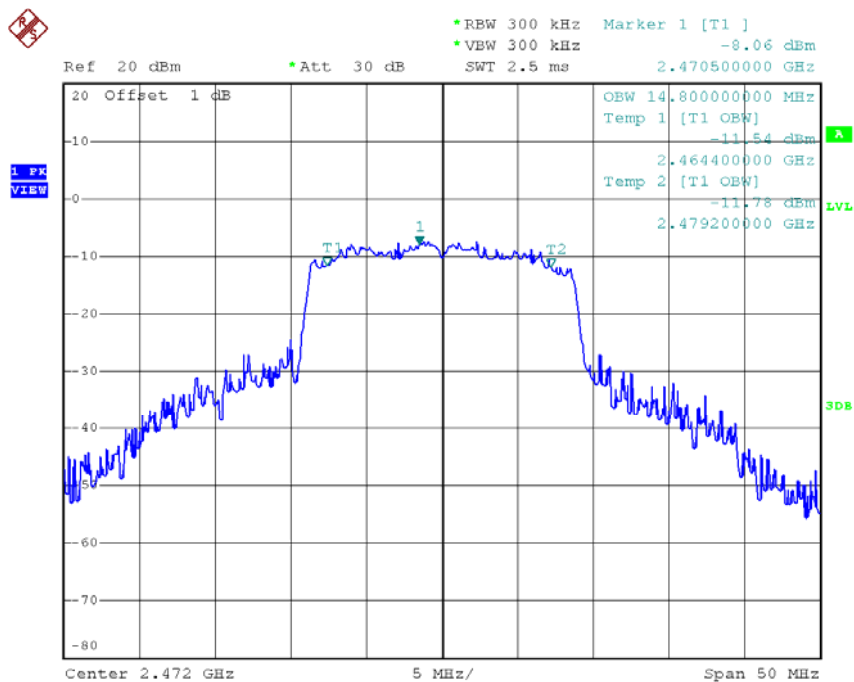

Date: 17.NOV.2015 16:23:26

Low Voltage CH01 -99 % OBW

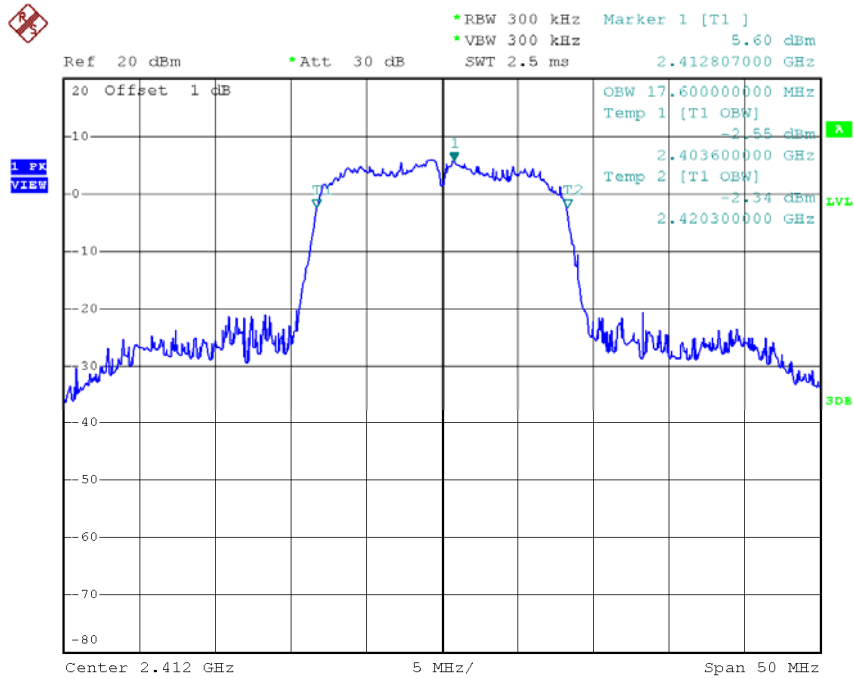

Date: 13.NOV.2015 18:20:01

Low Voltage CH01 -90 % OBW

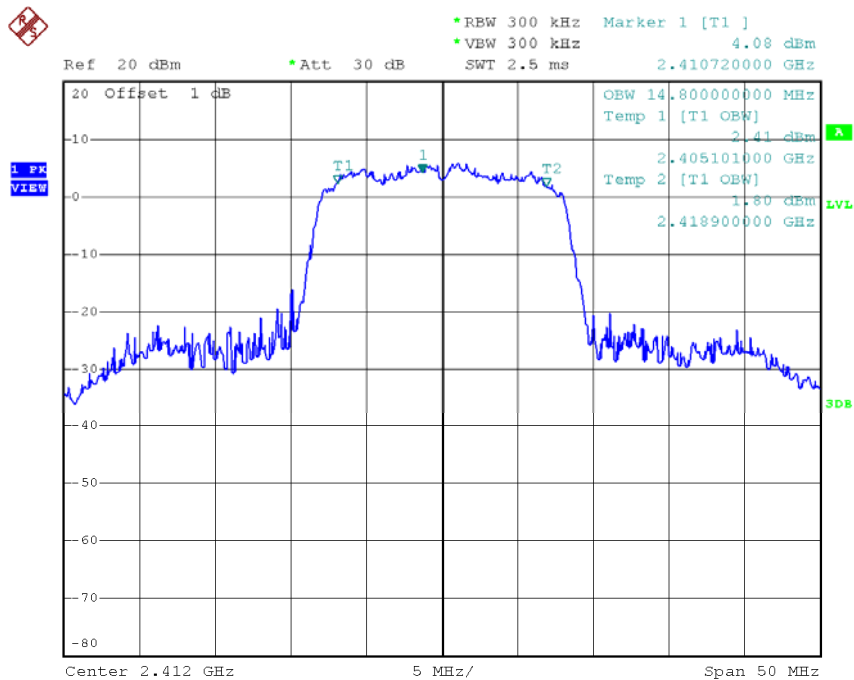

Date: 13.NOV.2015 18:20:43

Low Voltage CH07 -99 % OBW

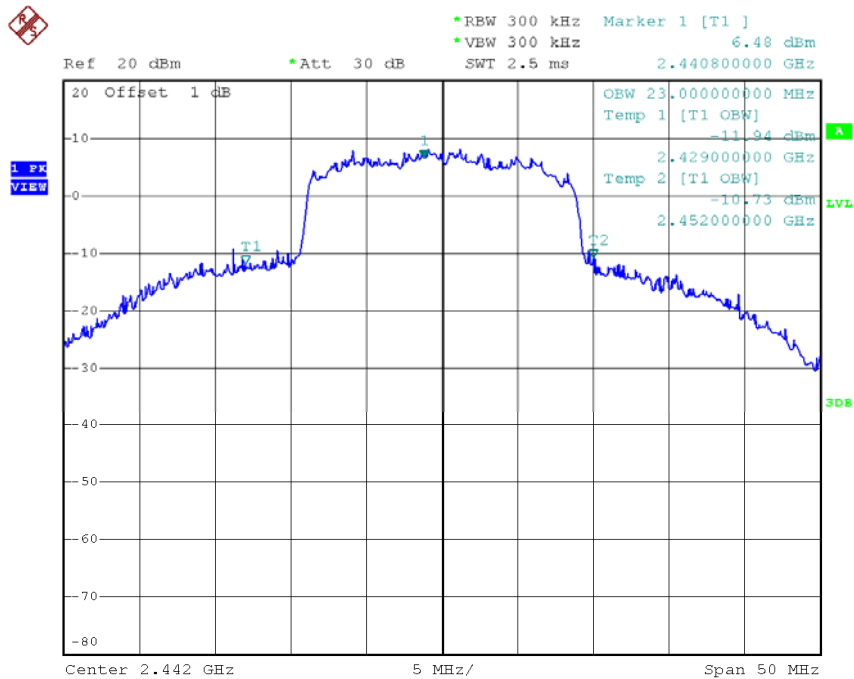

Date: 17.NOV.2015 16:15:59

Low Voltage CH07 -90 % OBW

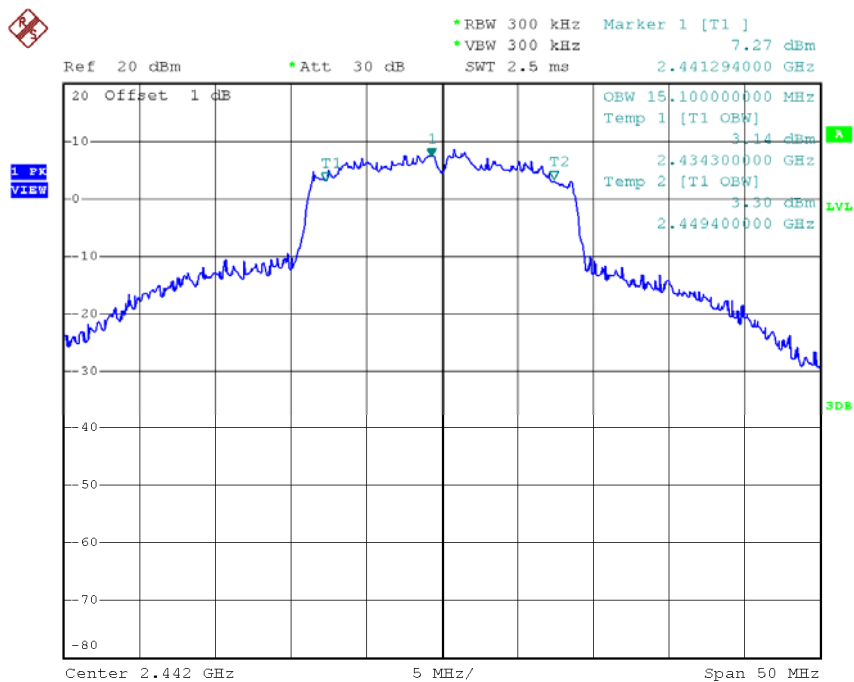

Date: 17.NOV.2015 16:15:52

Low Voltage CH13 -99 % OBW

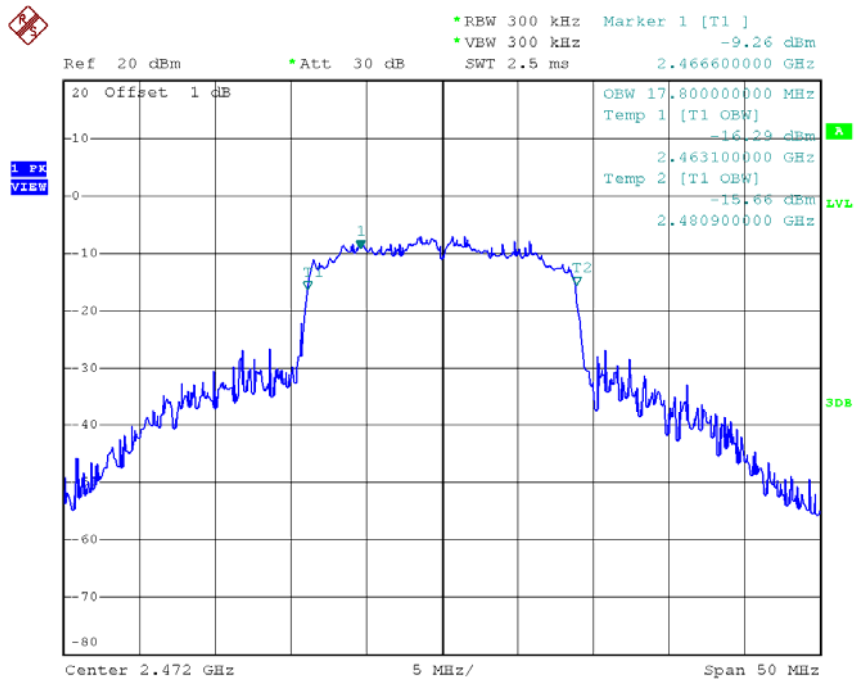

Date: 17.NOV.2015 16:28:57

Low Voltage CH13 -90 % OBW

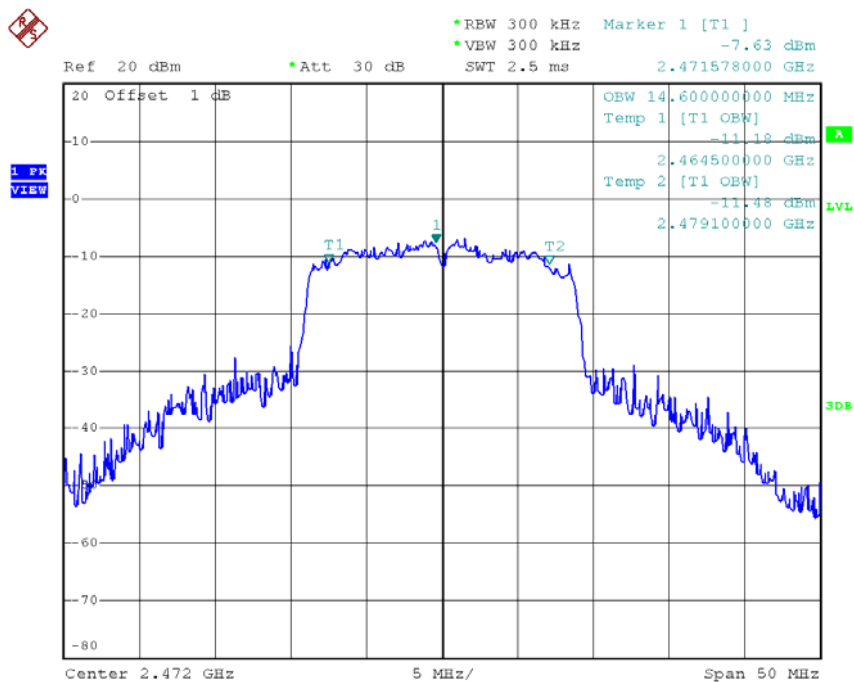

Date: 17.NOV.2015 16:28:49

Test Mode:	802.11n(HT20)/CH01,CH07,CH13
------------	------------------------------

Test Voltage (V)	Normal Voltage			Remarks
Test Frequency (MHz)	2412	2442	2472	Low/Mid/High of test frequency range
Occupied bandwidth (MHz)	18.00	24.10	17.70	Limit \leq 26 MHz (RBW/VBW : 300kHz)
Spreading Bandwidth (MHz)	14.80	15.00	14.70	\geq 500 kHz (FHSS, DSSS)
Spread-factor=Spreading Bandwidth/1.5	9.87	10.00	9.80	Spread Factor Limit \geq 5 (DSSS and FHSS)

Test Voltage (V)	High Voltage			Remarks
Test Frequency (MHz)	2412	2442	2472	Low/Mid/High of test frequency range
Occupied bandwidth (MHz)	17.90	24.10	17.80	Limit \leq 26 MHz (RBW/VBW : 300kHz)
Spreading Bandwidth (MHz)	14.80	15.10	14.70	\geq 500 kHz (FHSS, DSSS)
Spread-factor=Spreading Bandwidth/1.5	9.87	10.07	9.80	Spread Factor Limit \geq 5 (DSSS and FHSS)

Test Voltage (V)	Low Voltage			Remarks
Test Frequency (MHz)	2412	2442	2472	Low/Mid/High of test frequency range
Occupied bandwidth (MHz)	17.90	24.00	17.80	Limit \leq 26 MHz (RBW/VBW : 300kHz)
Spreading Bandwidth (MHz)	14.80	15.00	14.70	\geq 500 kHz (FHSS, DSSS)
Spread-factor=Spreading Bandwidth/1.5	9.87	10.00	9.80	Spread Factor Limit \geq 5 (DSSS and FHSS)

Note: 1. Spread Factor = Spread Bandwidth / TR

(TR = 1.375 for 802.11b; TR = 1.5 for 802.11g / 802.11n (20M); TR = 3 for 802.11n (40M))

Normal Voltage CH01 -99 % OBW

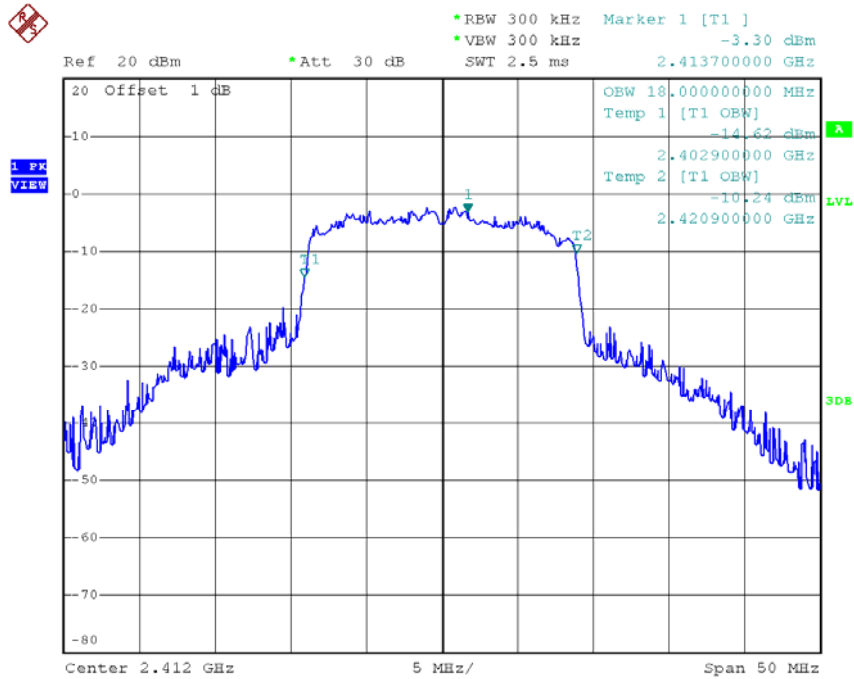

Date: 17.NOV.2015 17:13:38

Normal Voltage CH01 -90 % OBW

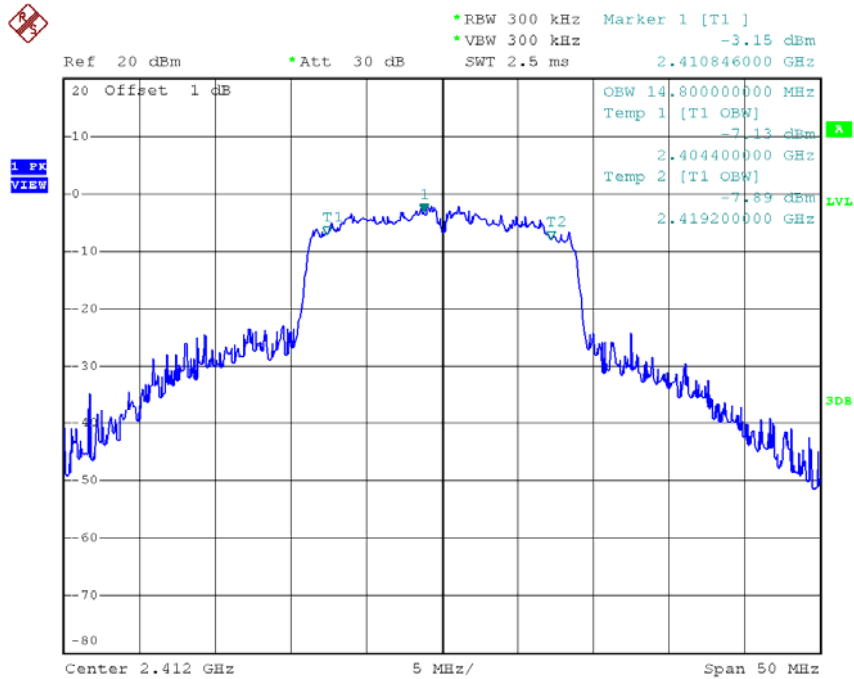

Date: 17.NOV.2015 17:13:30

Normal Voltage CH07 -99 % OBW

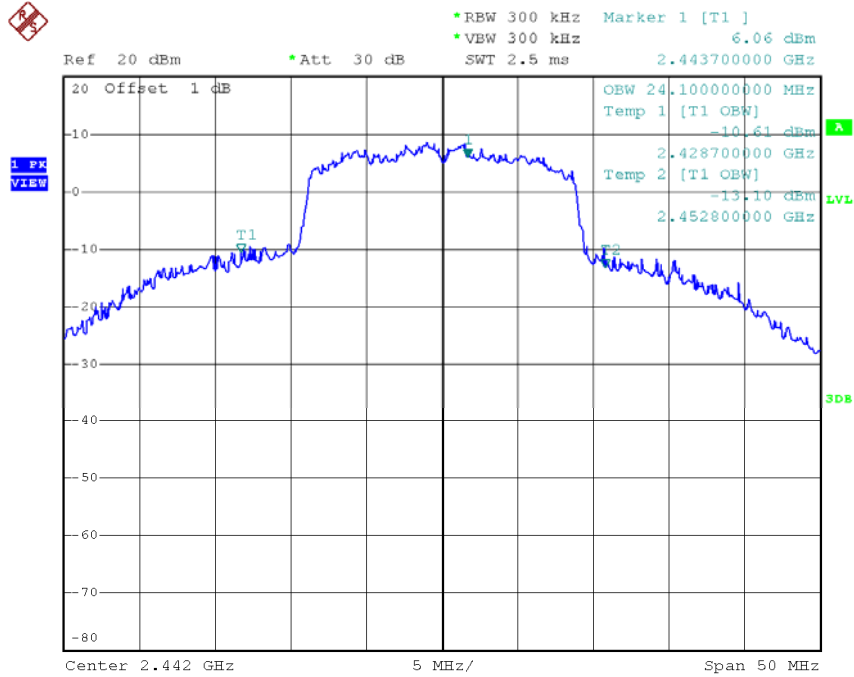

Date: 17.NOV.2015 17:29:38

Normal Voltage CH07 -90 % OBW

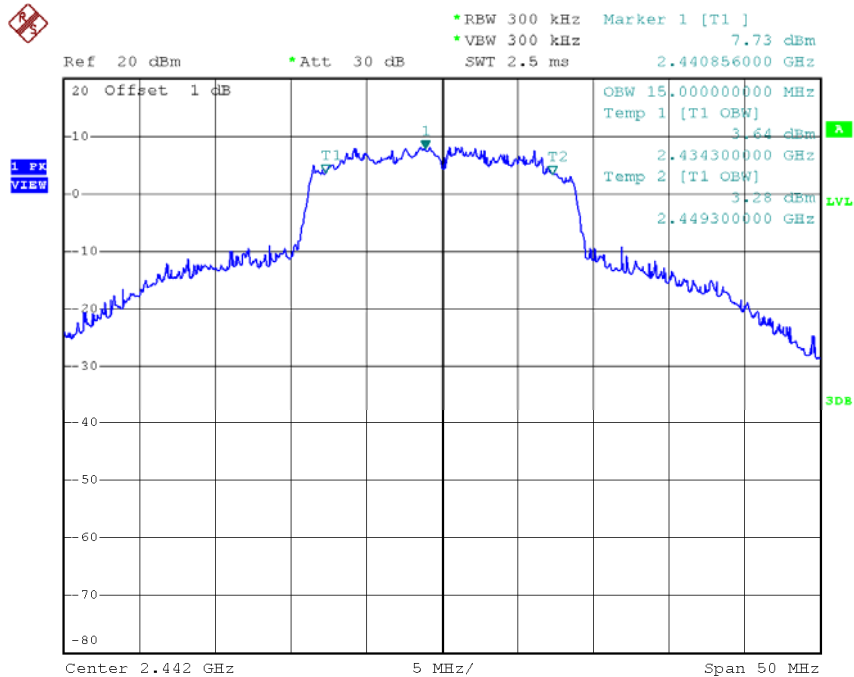

Date: 17.NOV.2015 17:29:30

Normal Voltage CH13 -99 % OBW

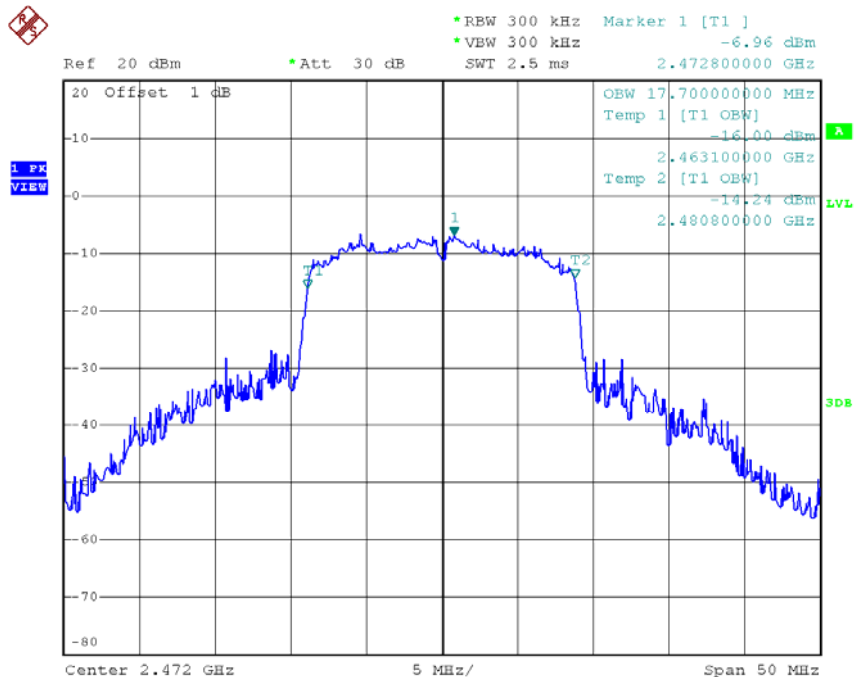

Date: 17.NOV.2015 18:04:32

Normal Voltage CH13 -90 % OBW

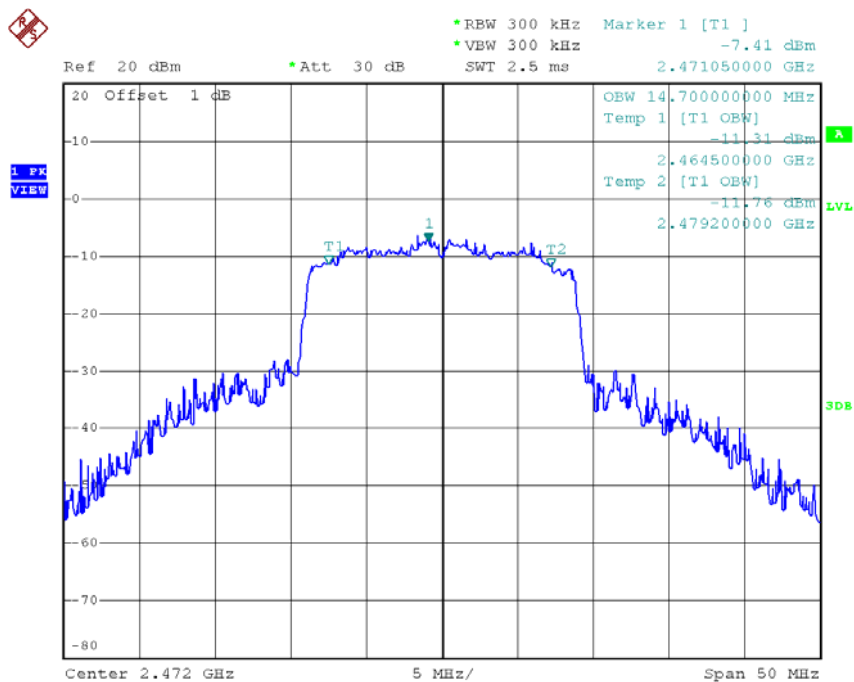

Date: 17.NOV.2015 18:04:24

High Voltage CH01 -99 % OBW

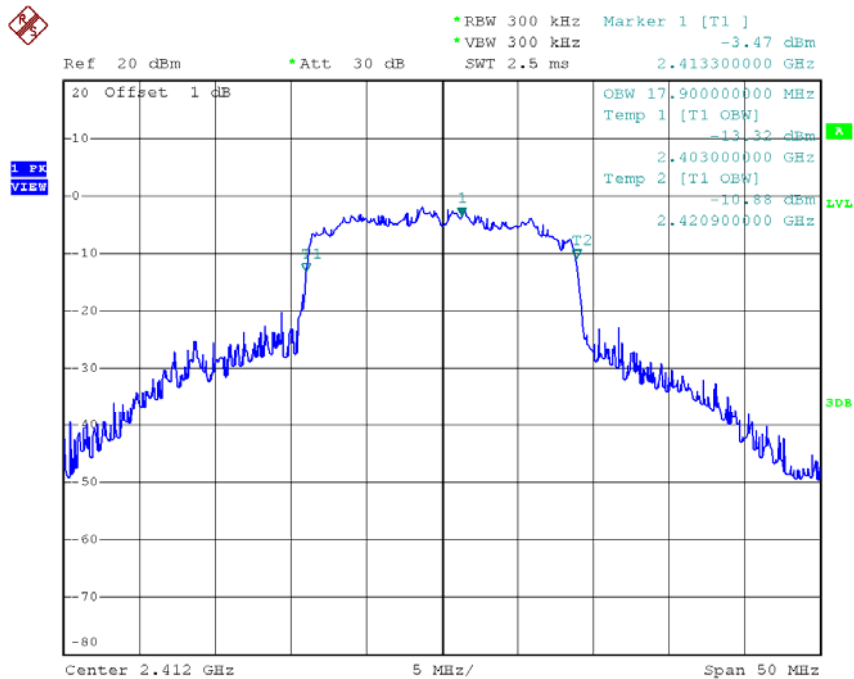

Date: 17.NOV.2015 17:10:52

High Voltage CH01 -90 % OBW

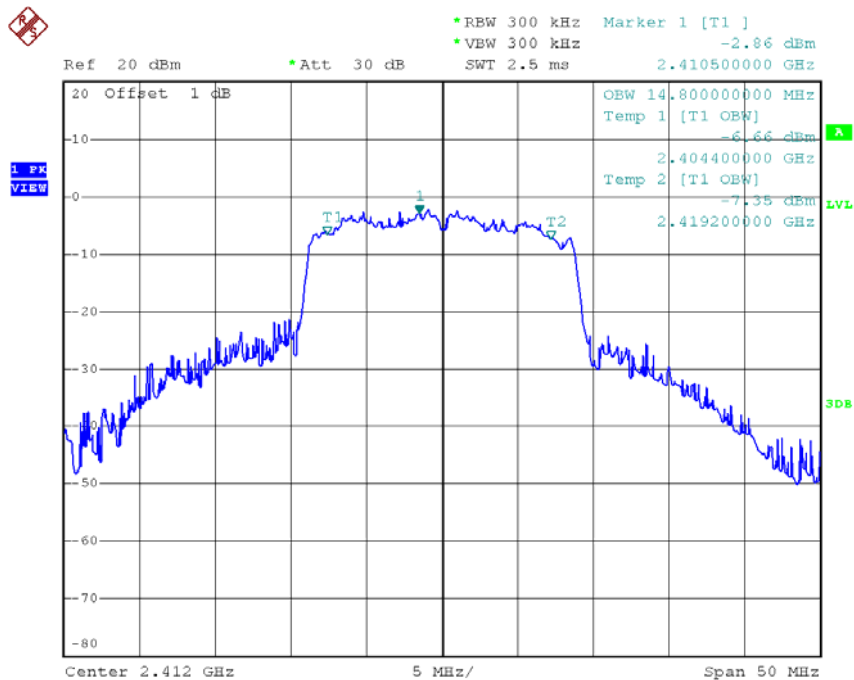

Date: 17.NOV.2015 17:10:44

High Voltage CH07 -99 % OBW

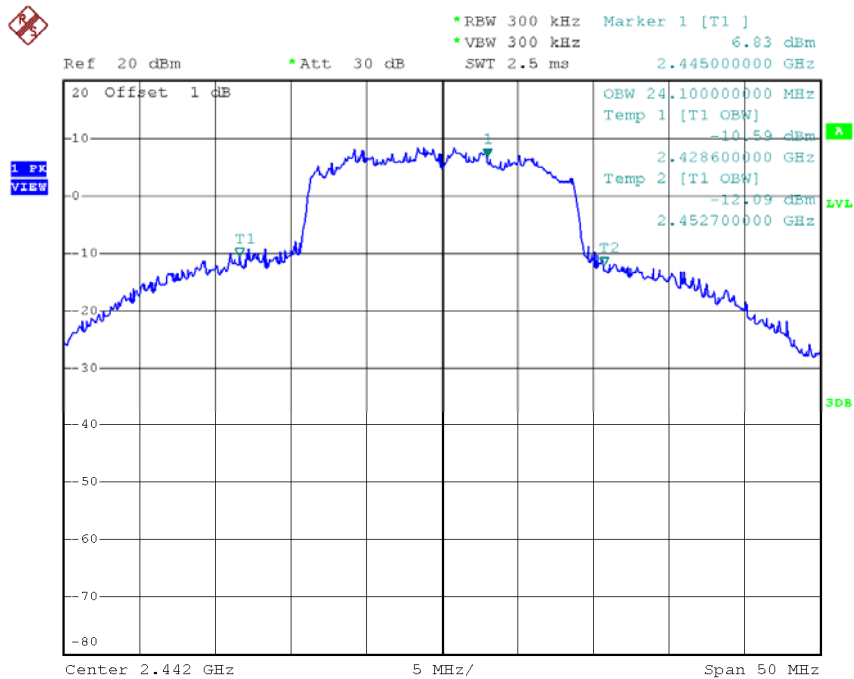

Date: 17.NOV.2015 17:26:52

High Voltage CH07 -90 % OBW

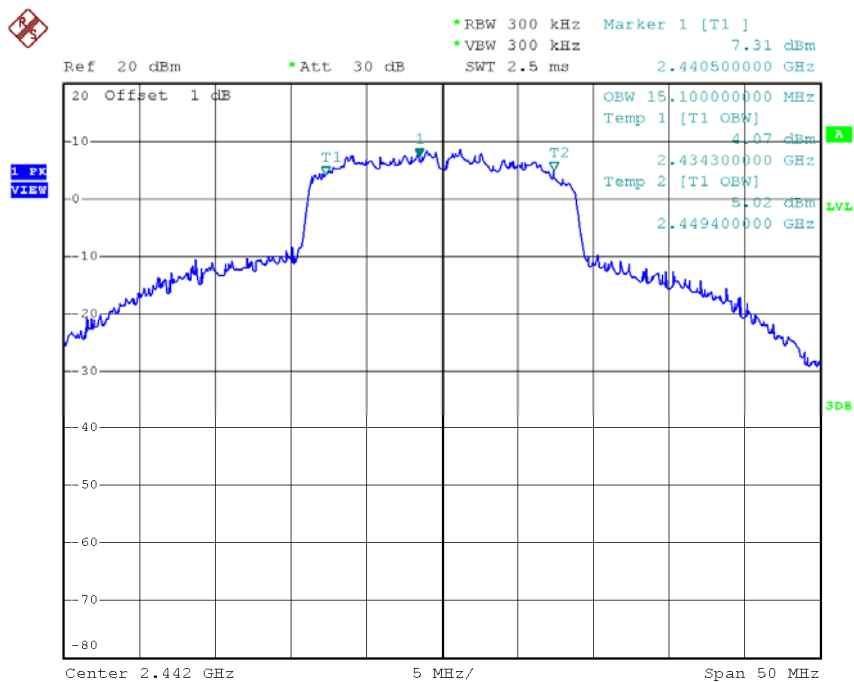

Date: 17.NOV.2015 17:26:43

High Voltage CH13 -99 % OBW

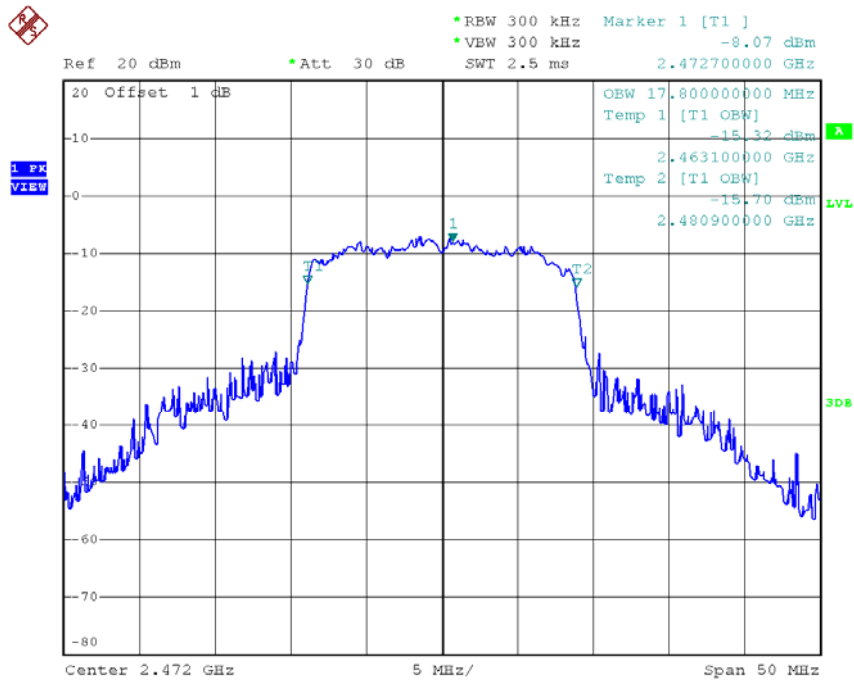

Date: 17.NOV.2015 18:01:39

High Voltage CH13 -90 % OBW

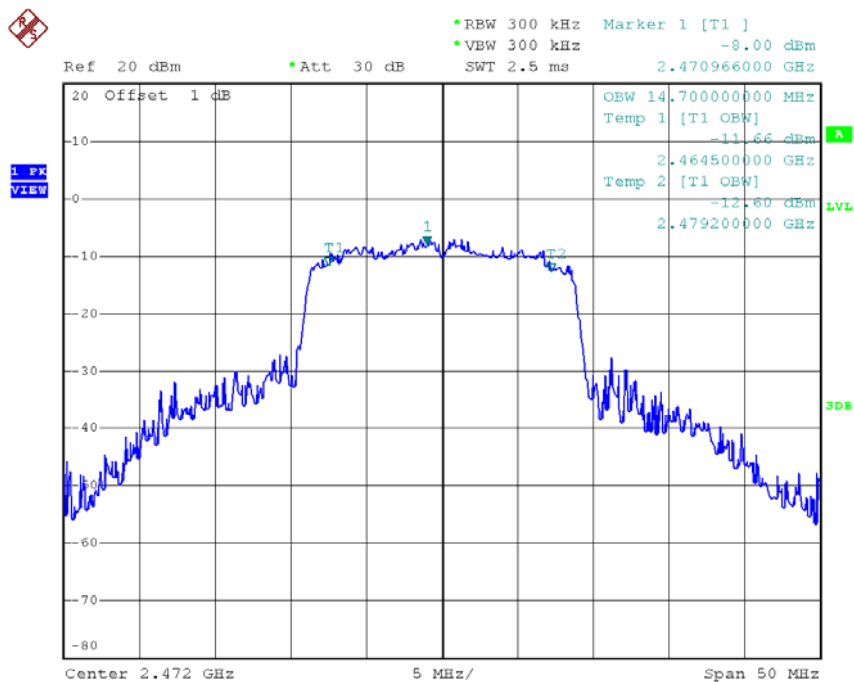

Date: 17.NOV.2015 18:01:31

Low Voltage CH01 -99 % OBW

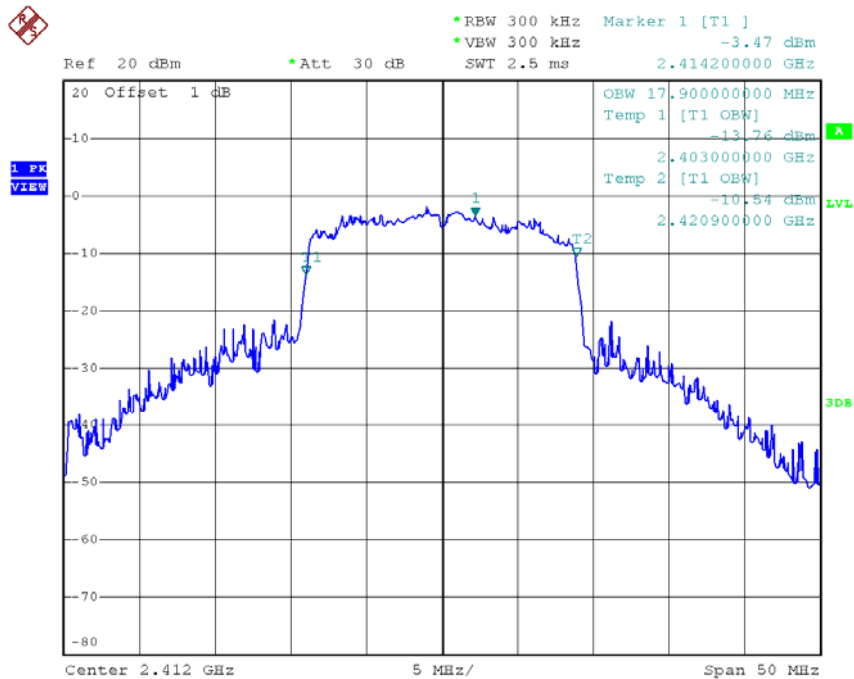

Date: 17.NOV.2015 17:16:26

Low Voltage CH01 -90 % OBW

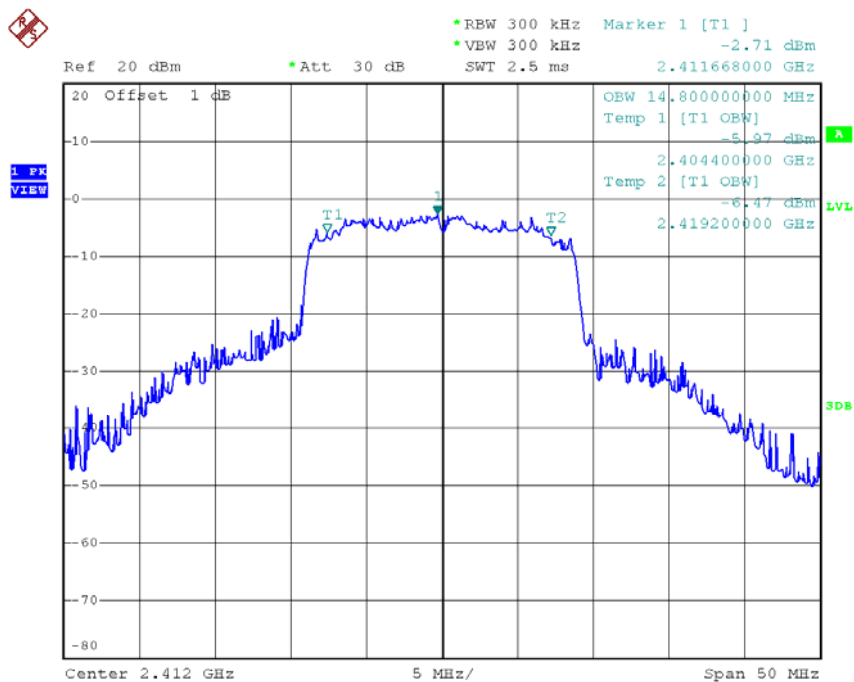

Date: 17.NOV.2015 17:16:18

Low Voltage CH07 -99 % OBW

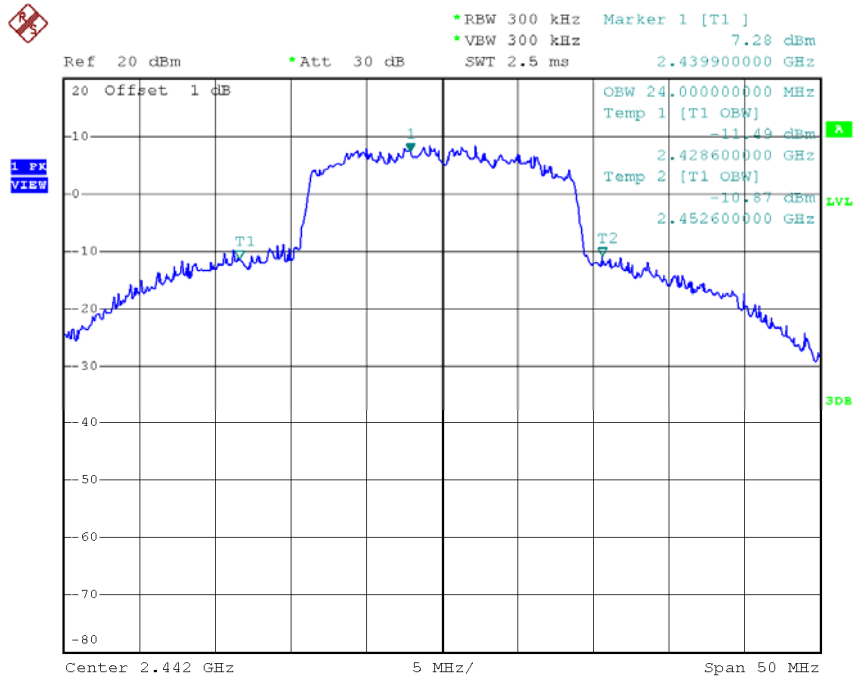

Date: 17.NOV.2015 17:32:22

Low Voltage CH07 -90 % OBW

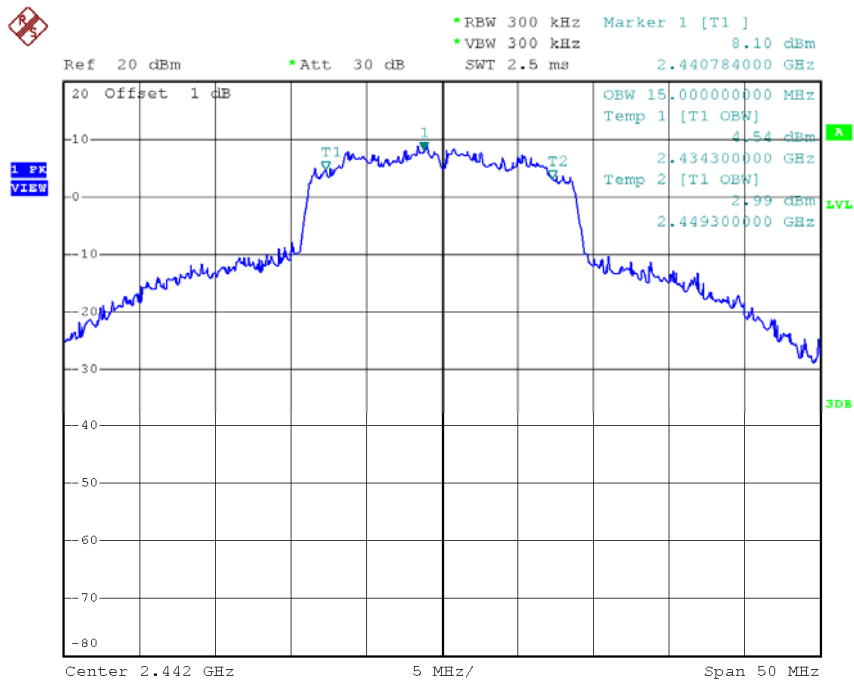

Date: 17.NOV.2015 17:32:14

Low Voltage CH13 -99 % OBW

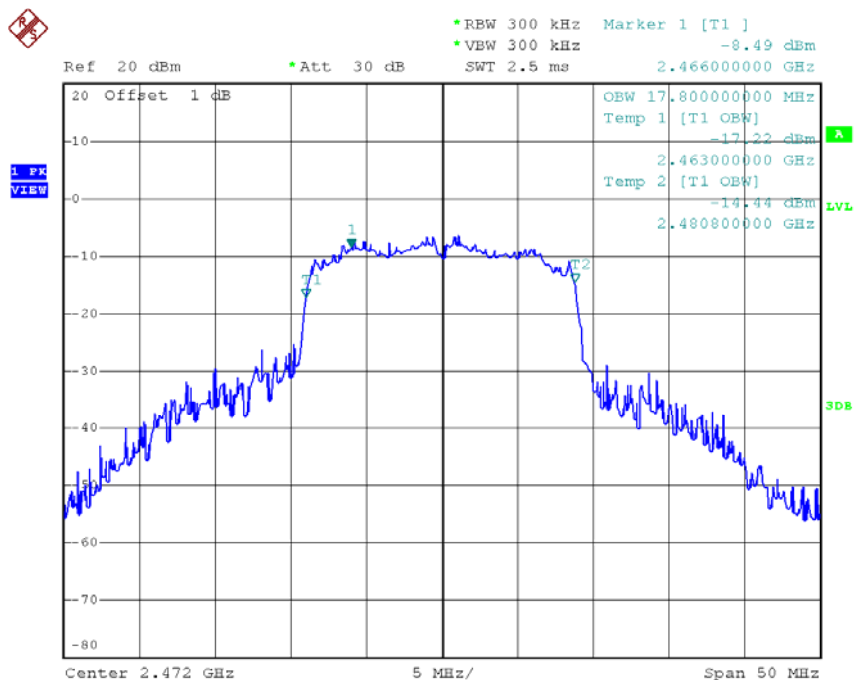

Date: 17.NOV.2015 18:07:16

Low Voltage CH13 -90 % OBW

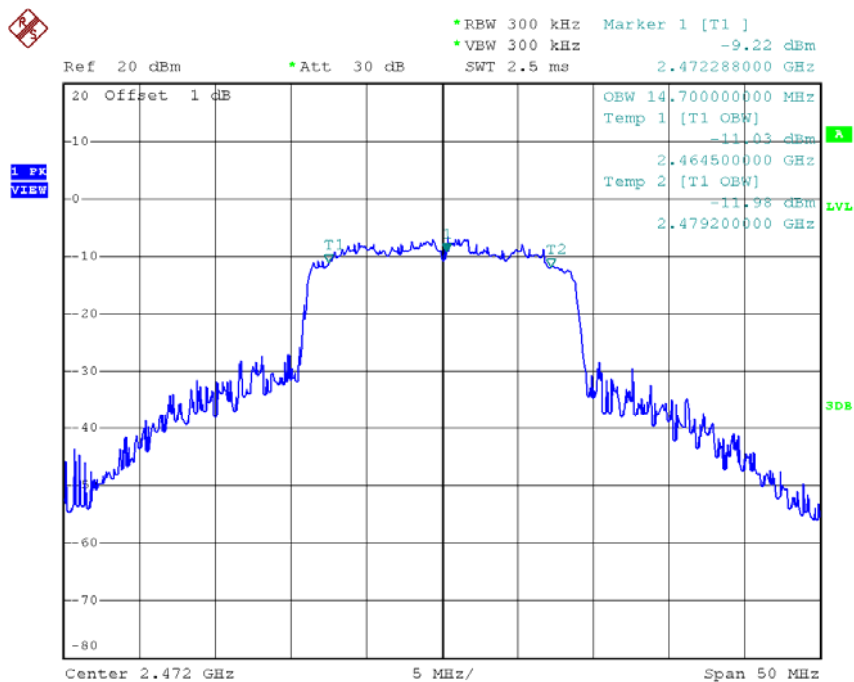

Date: 17.NOV.2015 18:07:08

For Dipole antenna

Test Mode:	802.11b/CH01,CH07,CH13
------------	------------------------

Test Voltage (V)	Normal Voltage			Remarks
Test Frequency (MHz)	2412	2442	2472	Low/Mid/High of test frequency range
Occupied bandwidth (MHz)	13.10	13.10	12.70	Limit \leq 26 MHz (RBW/VBW : 300kHz)
Spreading Bandwidth (MHz)	8.60	8.50	8.40	\geq 500 kHz (FHSS, DSSS)
Spread-factor=Spreading Bandwidth/1.375	6.25	6.18	6.11	Spread Factor Limit \geq 5 (DSSS and FHSS)

Test Voltage (V)	High Voltage			Remarks
Test Frequency (MHz)	2412	2442	2472	Low/Mid/High of test frequency range
Occupied bandwidth (MHz)	13.10	13.10	12.80	Limit \leq 26 MHz (RBW/VBW : 300kHz)
Spreading Bandwidth (MHz)	8.60	8.60	8.40	\geq 500 kHz (FHSS, DSSS)
Spread-factor=Spreading Bandwidth/1.375	6.25	6.25	6.11	Spread Factor Limit \geq 5 (DSSS and FHSS)

Test Voltage (V)	Low Voltage			Remarks
Test Frequency (MHz)	2412	2442	2472	Low/Mid/High of test frequency range
Occupied bandwidth (MHz)	13.10	13.10	12.70	Limit \leq 26 MHz (RBW/VBW : 300kHz)
Spreading Bandwidth (MHz)	8.60	8.60	8.40	\geq 500 kHz (FHSS, DSSS)
Spread-factor=Spreading Bandwidth/1.375	6.25	6.25	6.11	Spread Factor Limit \geq 5 (DSSS and FHSS)

Note: 1. Spread Factor = Spread Bandwidth / TR

(TR = 1.375 for 802.11b; TR = 1.5 for 802.11g / 802.11n (20M); TR = 3 for 802.11n (40M))

Normal Voltage CH01 -99 % OBW

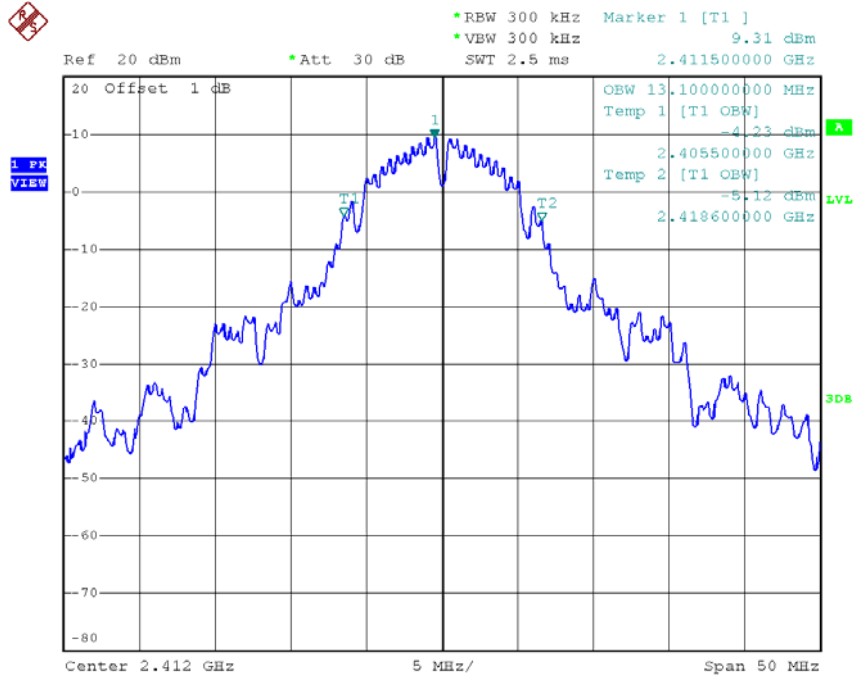

Date: 12.NOV.2015 16:27:43

Normal Voltage CH01 -90 % OBW

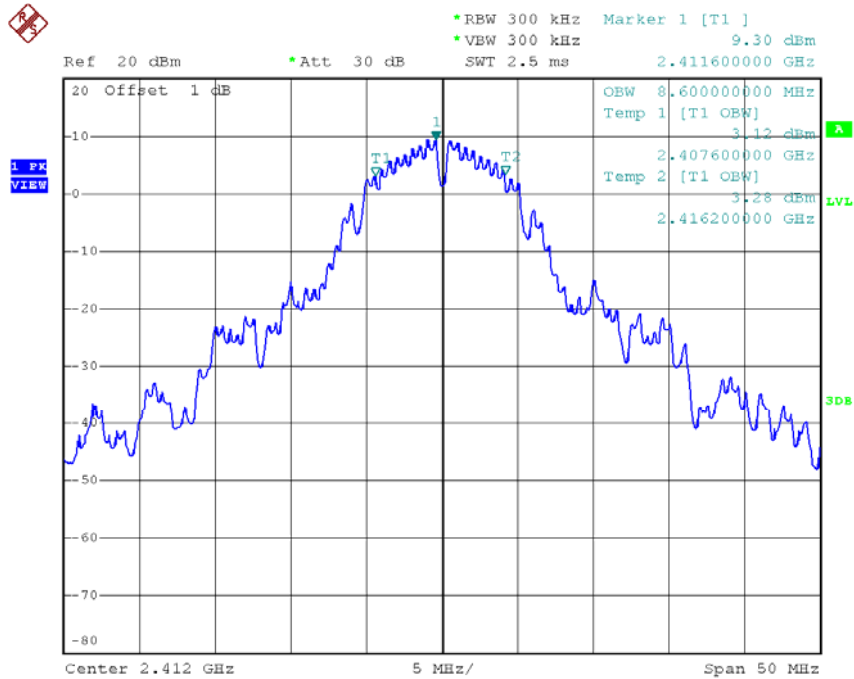

Date: 12.NOV.2015 16:27:36

Normal Voltage CH07 -99 % OBW

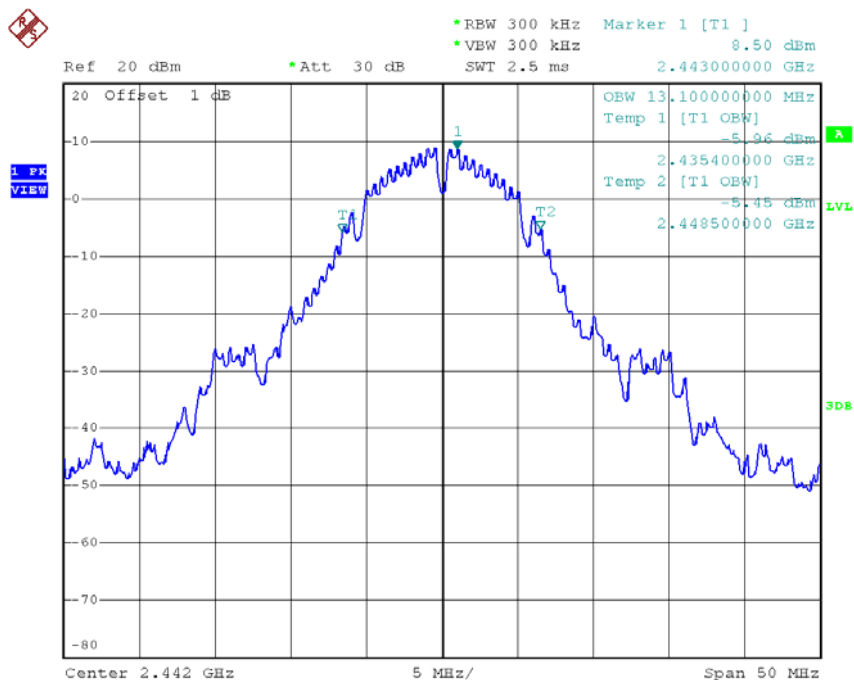

Date: 12.NOV.2015 16:35:45

Normal Voltage CH07 -90 % OBW

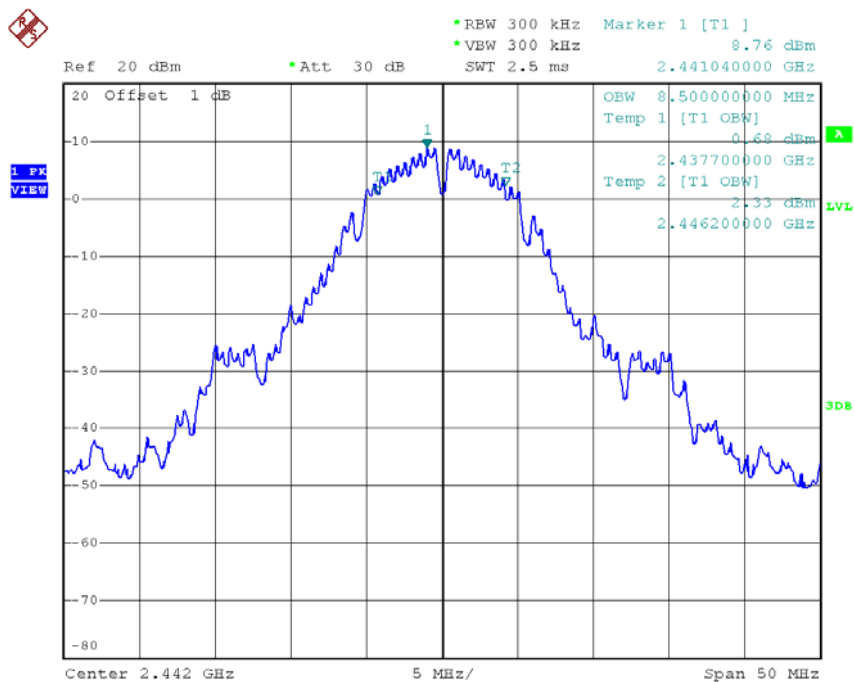

Date: 12.NOV.2015 16:35:38

Normal Voltage CH13 -99 % OBW

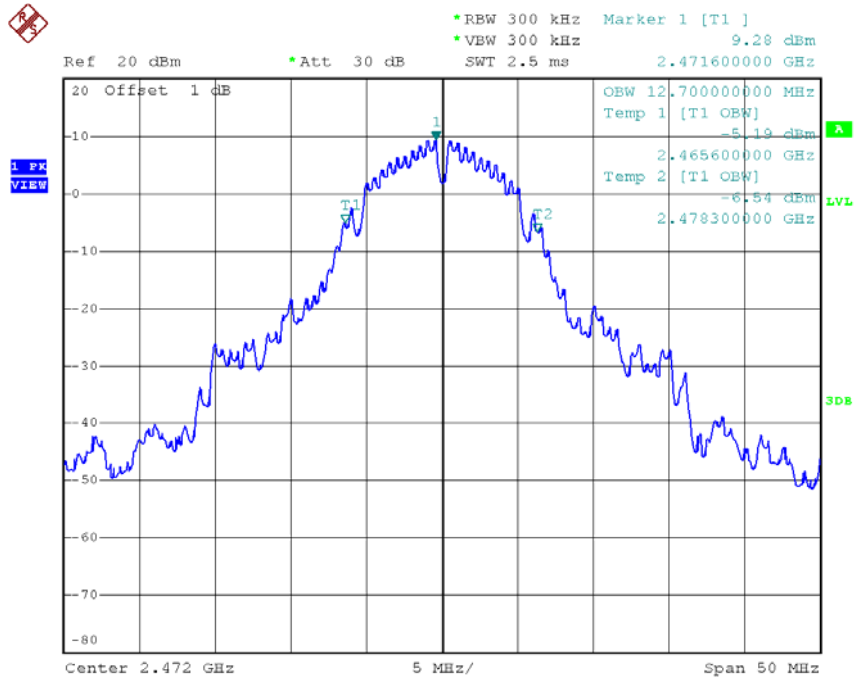

Date: 12.NOV.2015 16:44:07

Normal Voltage CH13 -90 % OBW

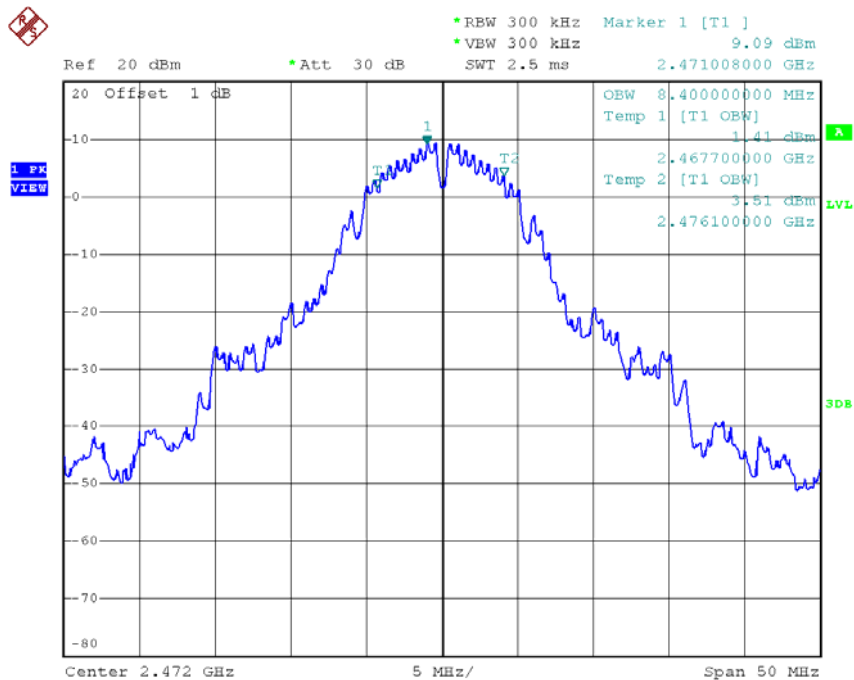

Date: 12.NOV.2015 16:44:00

High Voltage CH01 -99 % OBW

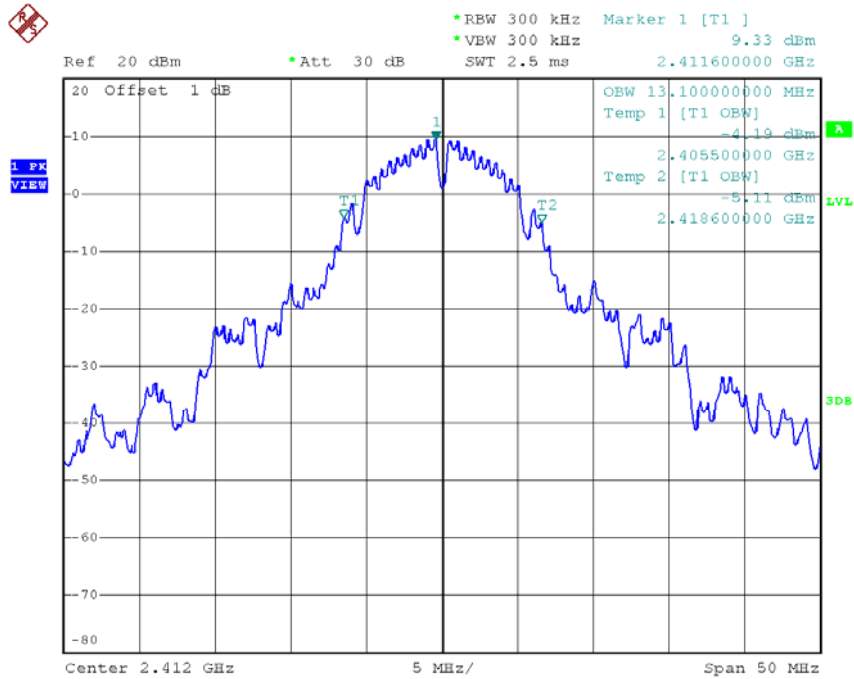

Date: 12.NOV.2015 16:27:22

High Voltage CH01 -90 % OBW

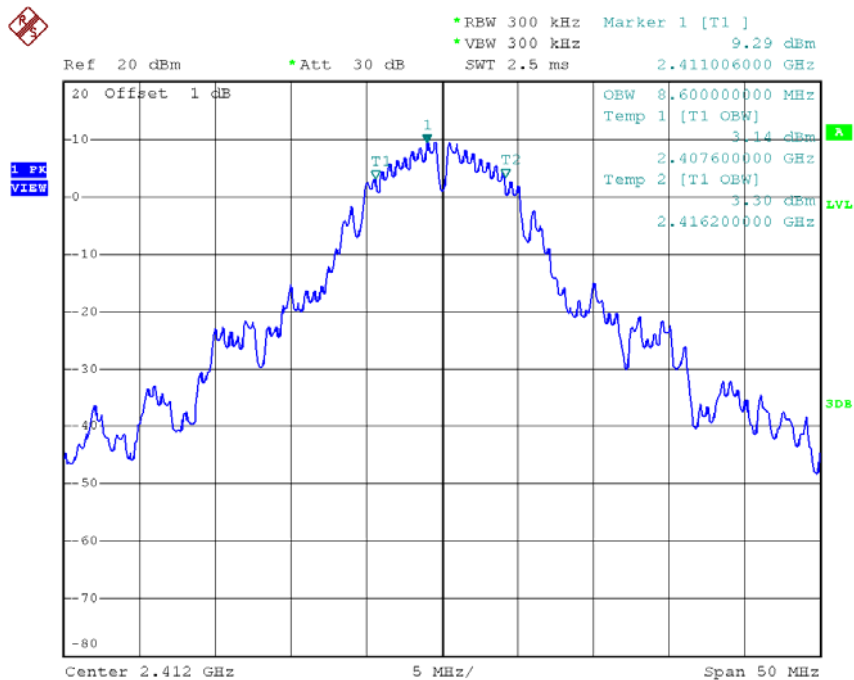

Date: 12.NOV.2015 16:27:15

High Voltage CH07 -99 % OBW

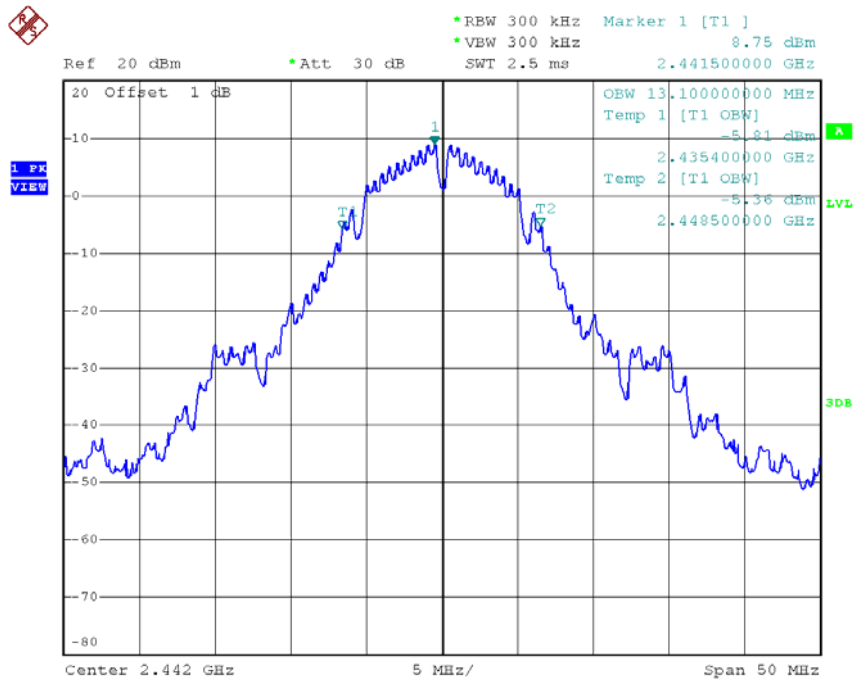

Date: 12.NOV.2015 16:33:24

High Voltage CH07 -90 % OBW

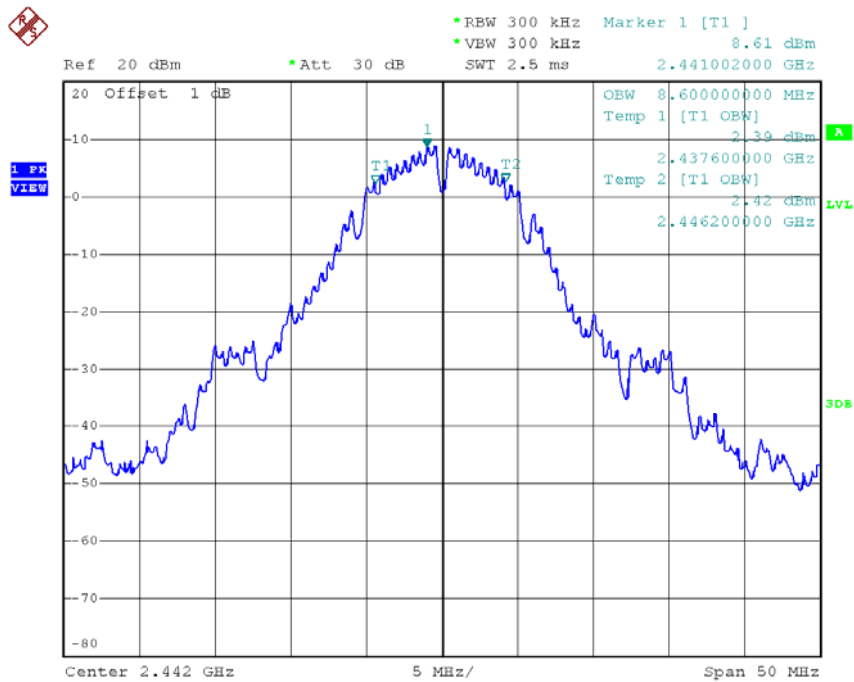

Date: 12.NOV.2015 16:33:17

High Voltage CH13 -99 % OBW

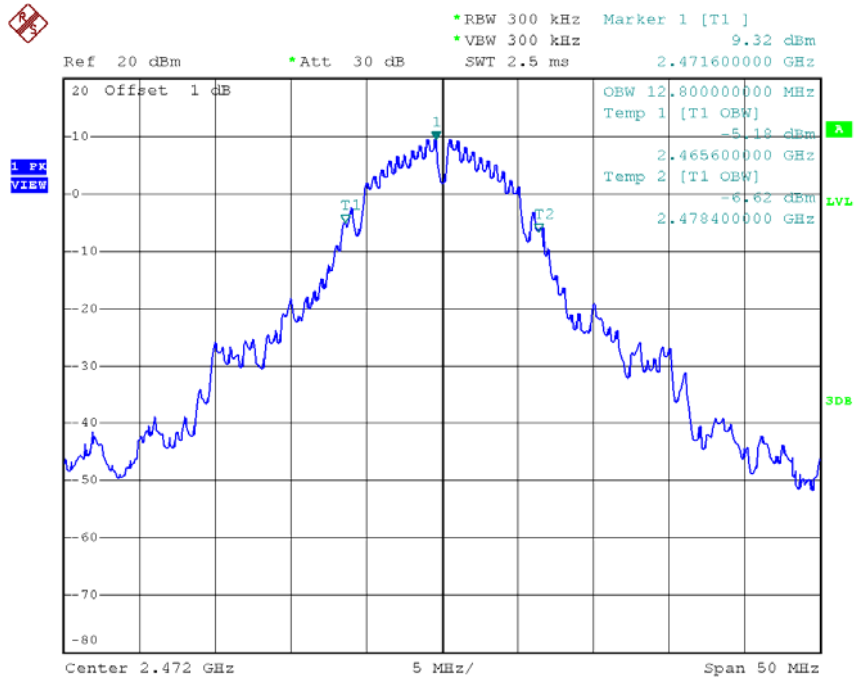

Date: 12.NOV.2015 16:41:49

High Voltage CH13 -90 % OBW

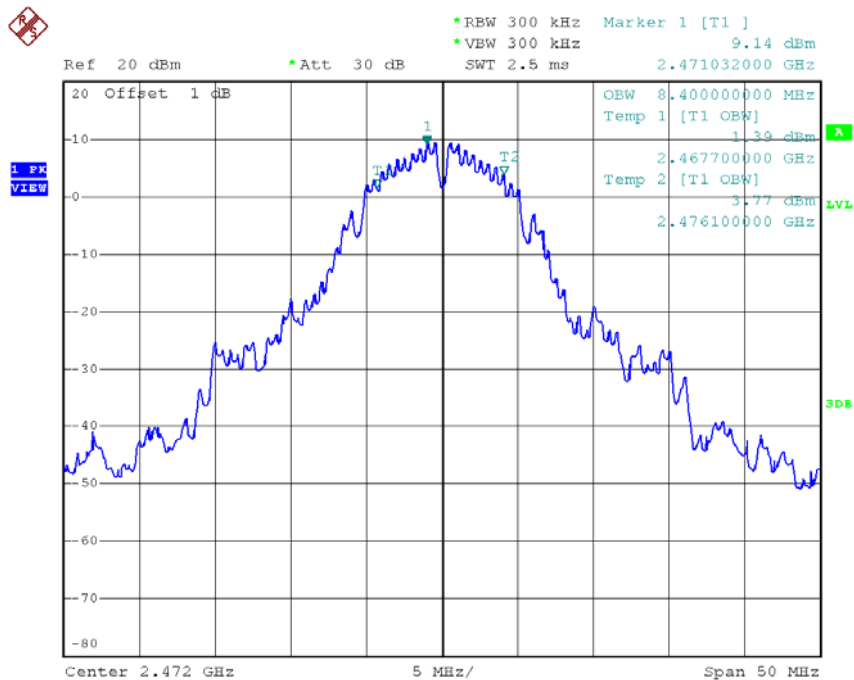

Date: 12.NOV.2015 16:41:41

Low Voltage CH01 -99 % OBW

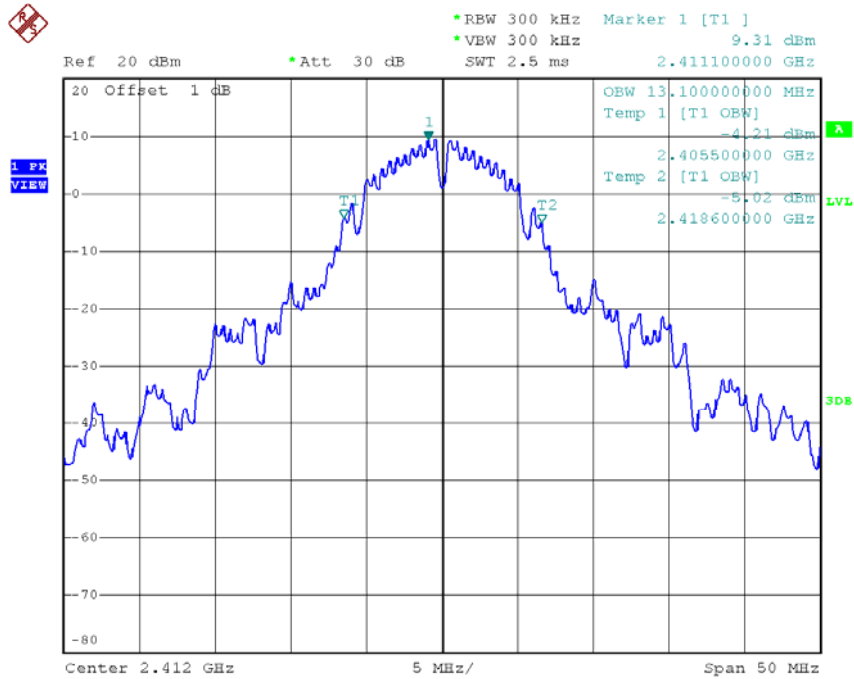

Date: 12.NOV.2015 16:28:08

Low Voltage CH01 -90 % OBW

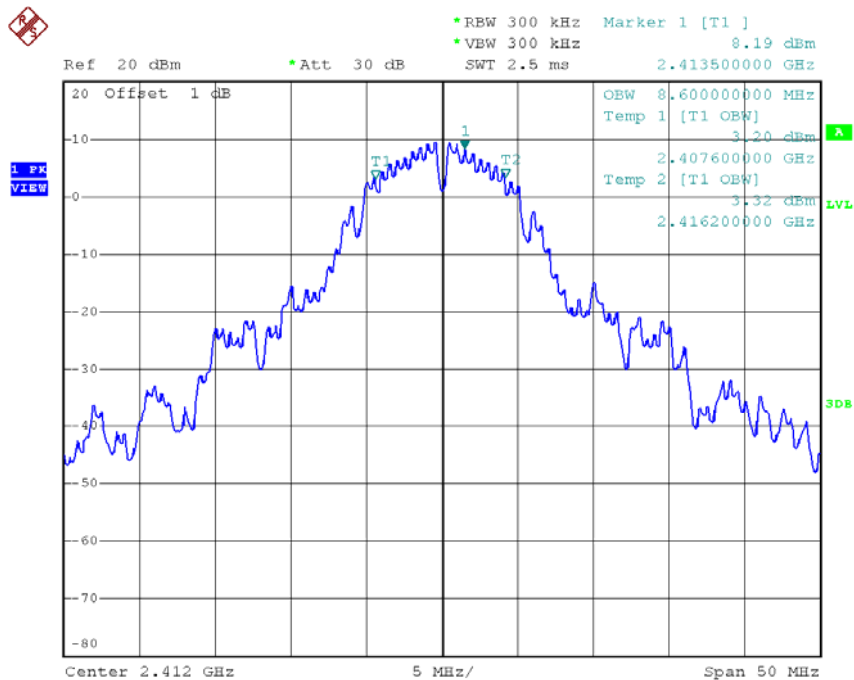

Date: 12.NOV.2015 16:28:01

Low Voltage CH07 -99 % OBW

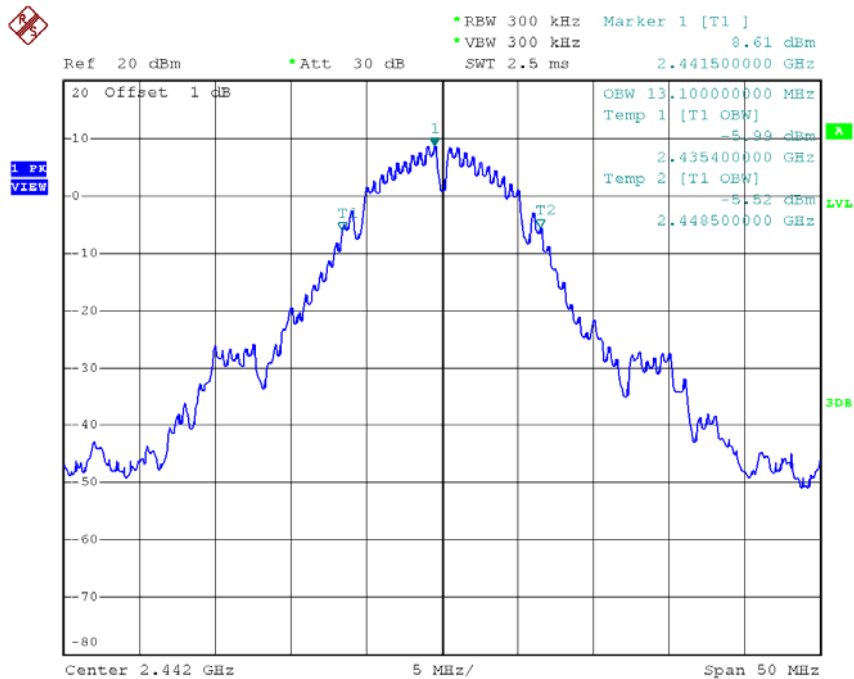

Date: 12.NOV.2015 16:38:05

Low Voltage CH07 -90 % OBW

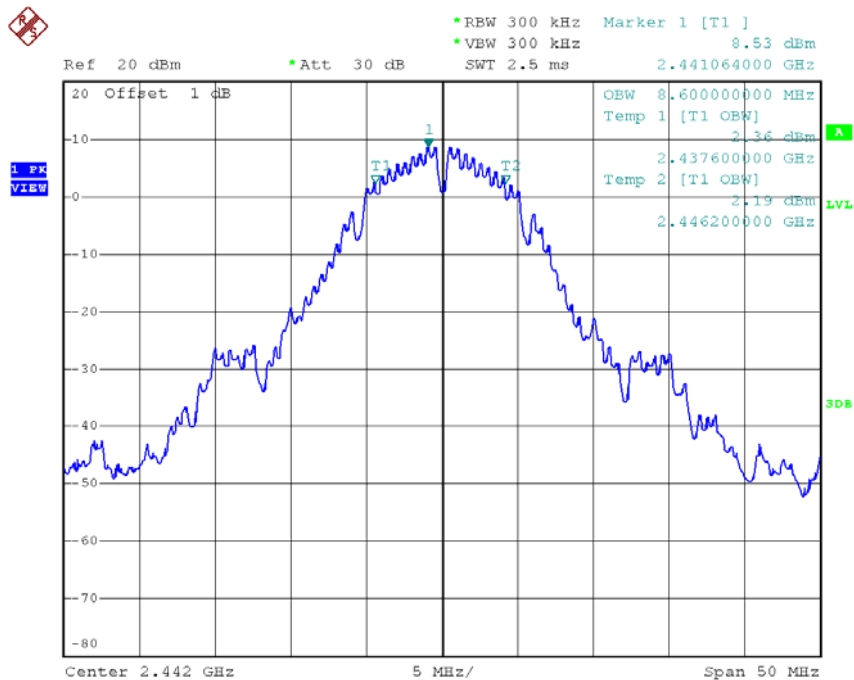

Date: 12.NOV.2015 16:37:58

Low Voltage CH13 -99 % OBW

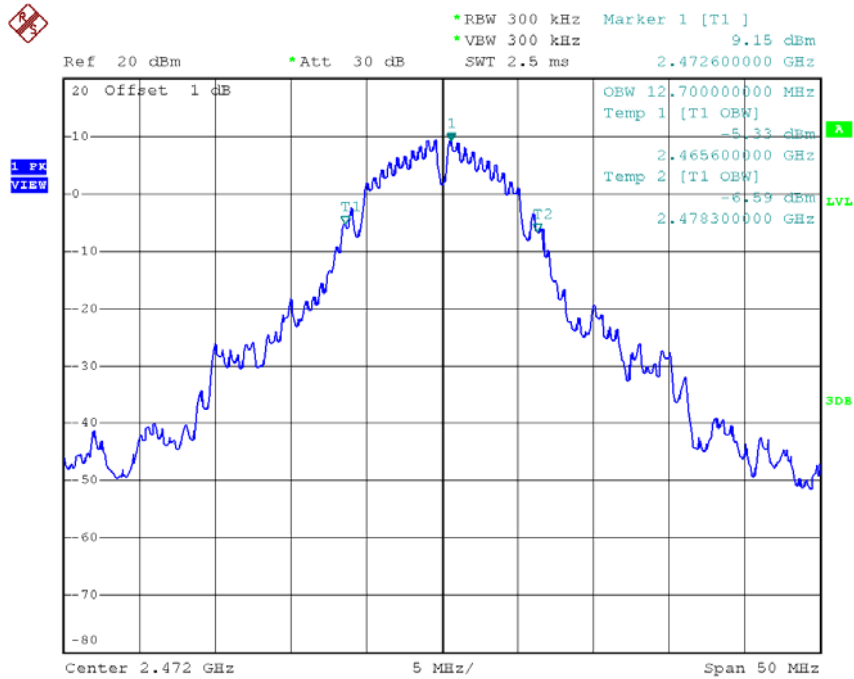

Date: 12.NOV.2015 16:46:28

Low Voltage CH13 -90 % OBW

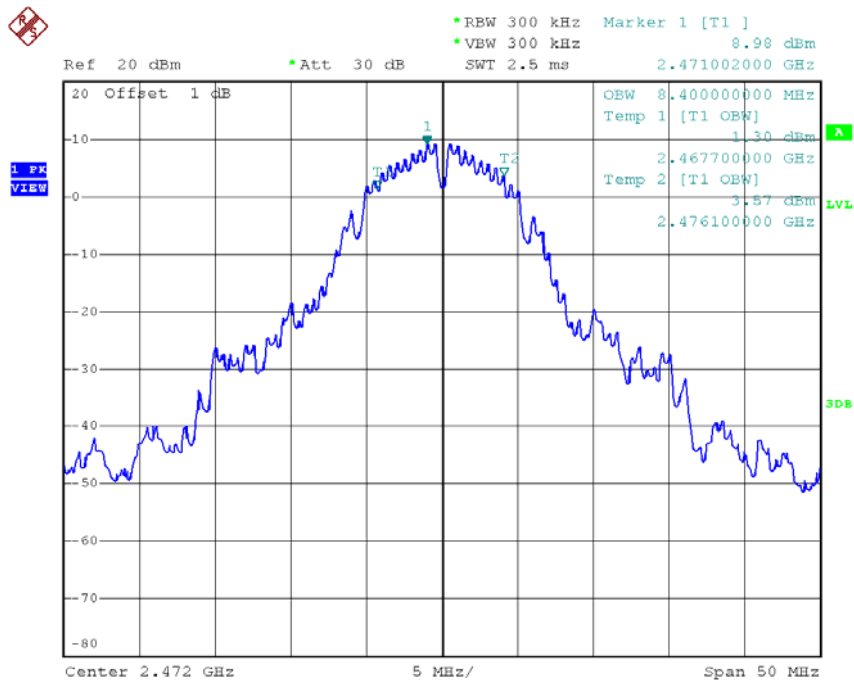

Date: 12.NOV.2015 16:46:21

Test Mode:	802.11g/CH01,CH07,CH13
------------	------------------------

Test Voltage (V)	Normal Voltage			Remarks
Test Frequency (MHz)	2412	2442	2472	Low/Mid/High of test frequency range
Occupied bandwidth (MHz)	16.60	16.70	16.60	Limit \leq 26 MHz (RBW/VBW : 300kHz)
Spreading Bandwidth (MHz)	13.90	13.80	13.90	\geq 500 kHz (FHSS, DSSS)
Spread-factor=Spreading Bandwidth/1.5	9.20	9.20	9.27	Spread Factor Limit \geq 5 (DSSS and FHSS)

Test Voltage (V)	High Voltage			Remarks
Test Frequency (MHz)	2412	2442	2472	Low/Mid/High of test frequency range
Occupied bandwidth (MHz)	16.60	16.70	16.60	Limit \leq 26 MHz (RBW/VBW : 300kHz)
Spreading Bandwidth (MHz)	13.80	13.80	14.00	\geq 500 kHz (FHSS, DSSS)
Spread-factor=Spreading Bandwidth/1.5	9.20	9.20	9.33	Spread Factor Limit \geq 5 (DSSS and FHSS)

Test Voltage (V)	Low Voltage			Remarks
Test Frequency (MHz)	2412	2442	2472	Low/Mid/High of test frequency range
Occupied bandwidth (MHz)	16.60	16.70	16.70	Limit \leq 26 MHz (RBW/VBW : 300kHz)
Spreading Bandwidth (MHz)	13.80	13.90	13.90	\geq 500 kHz (FHSS, DSSS)
Spread-factor=Spreading Bandwidth/1.5	9.20	9.27	9.27	Spread Factor Limit \geq 5 (DSSS and FHSS)

Note: 1. Spread Factor = Spread Bandwidth / TR

(TR = 1.375 for 802.11b; TR = 1.5 for 802.11g / 802.11n (20M); TR = 3 for 802.11n (40M))

Normal Voltage CH01 -99 % OBW

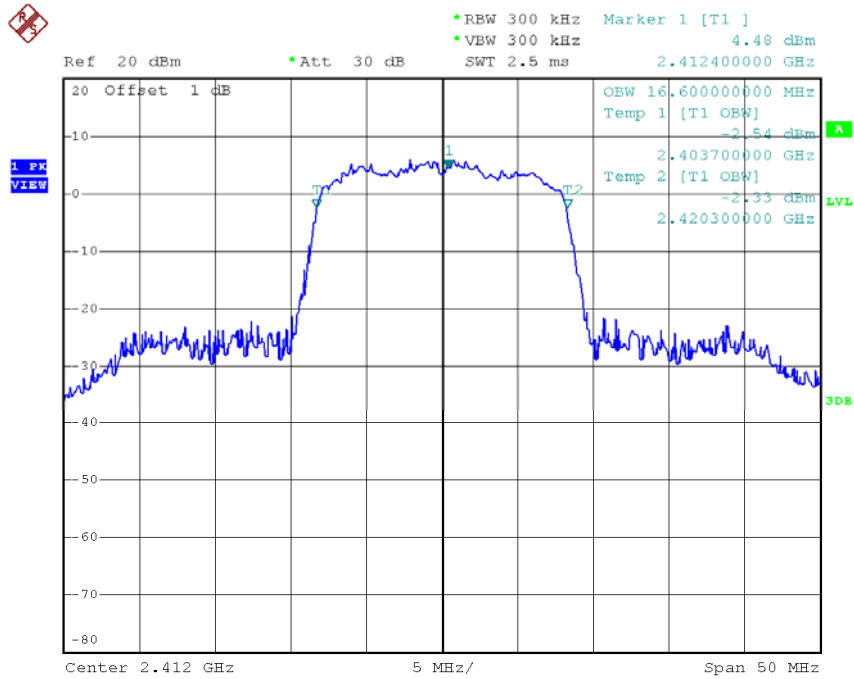

Date: 13.NOV.2015 18:19:17

Normal Voltage CH01 -90 % OBW

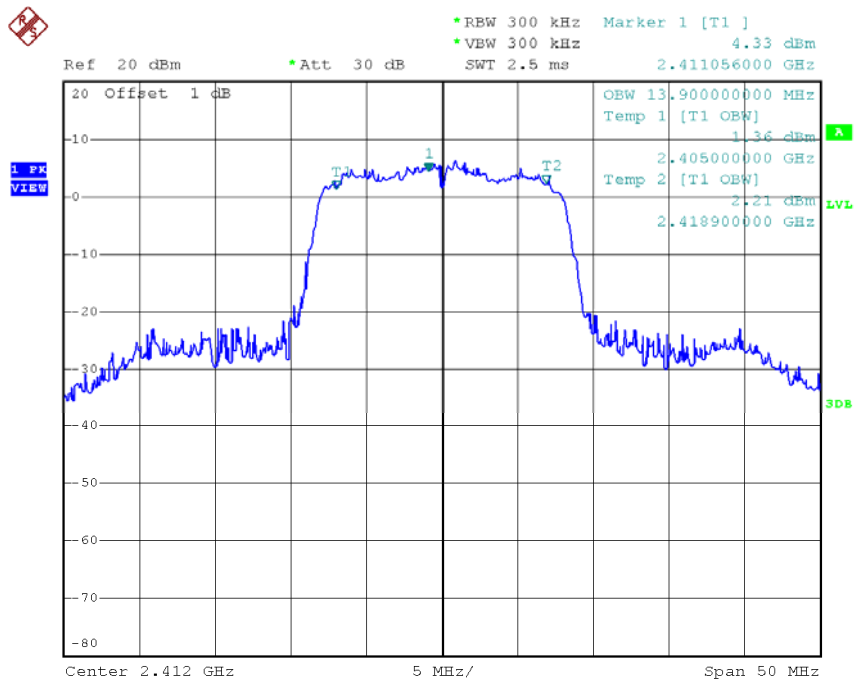

Date: 13.NOV.2015 18:19:09

Normal Voltage CH07 -99 % OBW

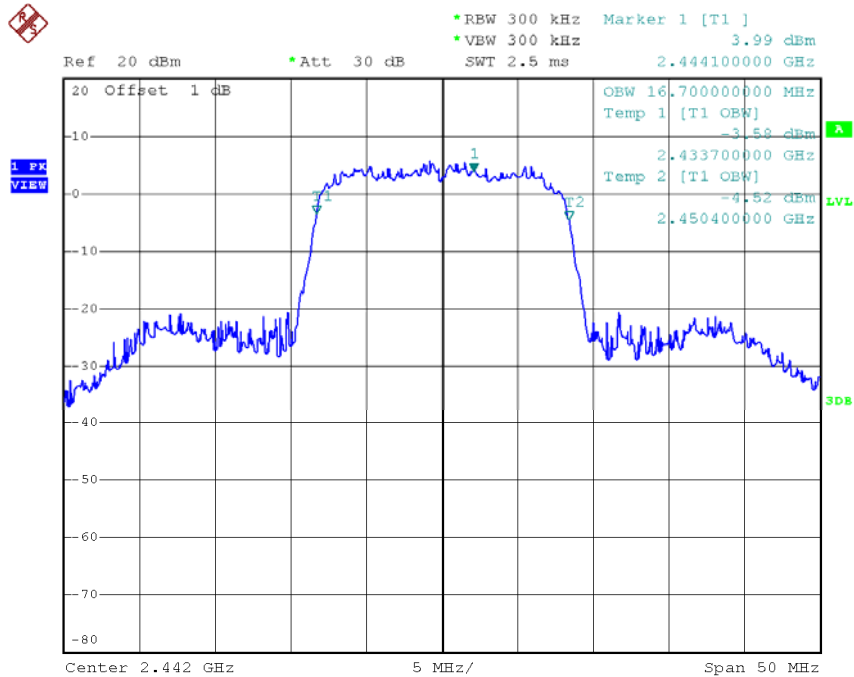

Date: 13.NOV.2015 18:48:41

Normal Voltage CH07 -90 % OBW

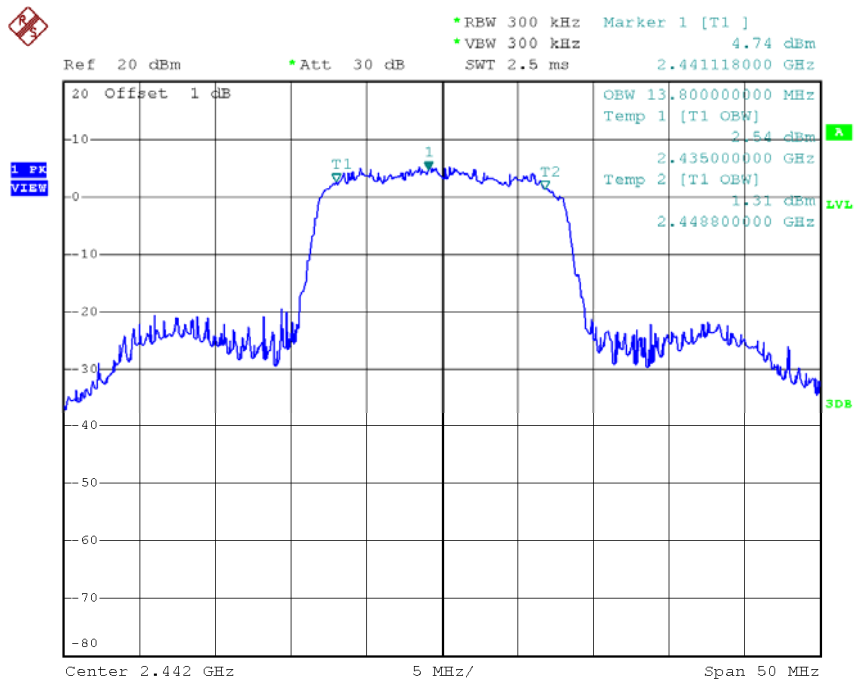

Date: 13.NOV.2015 18:48:33

Normal Voltage CH13 -99 % OBW

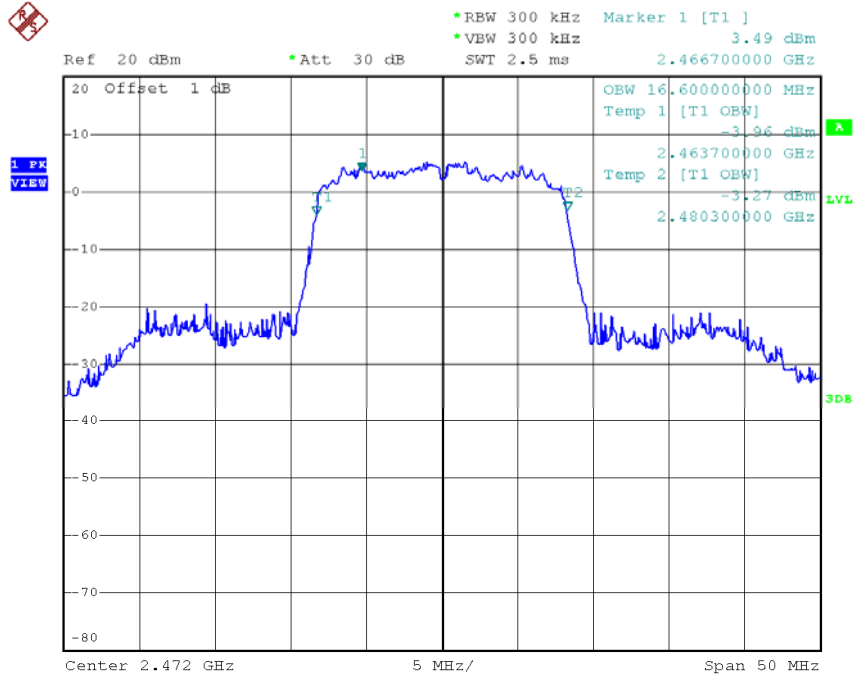

Date: 13.NOV.2015 19:09:51

Normal Voltage CH13 -90 % OBW

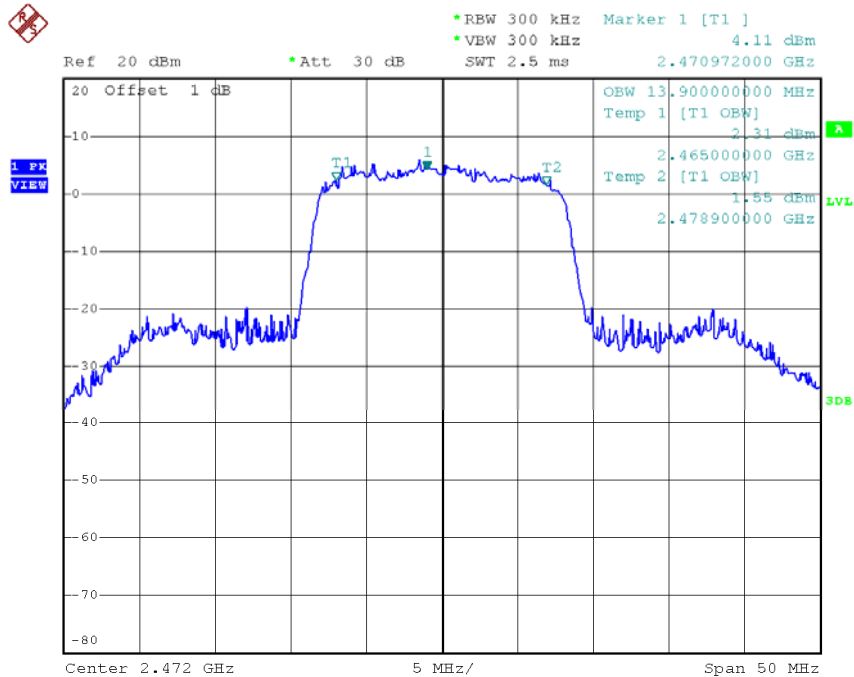

Date: 13.NOV.2015 19:09:43

High Voltage CH01 -99 % OBW

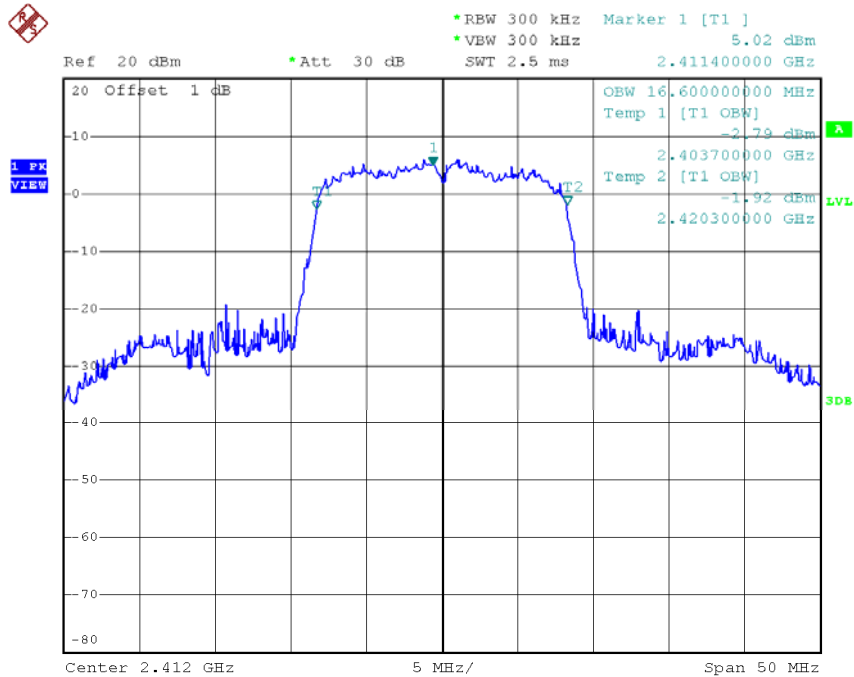

Date: 13.NOV.2015 18:17:46

High Voltage CH01 -90 % OBW

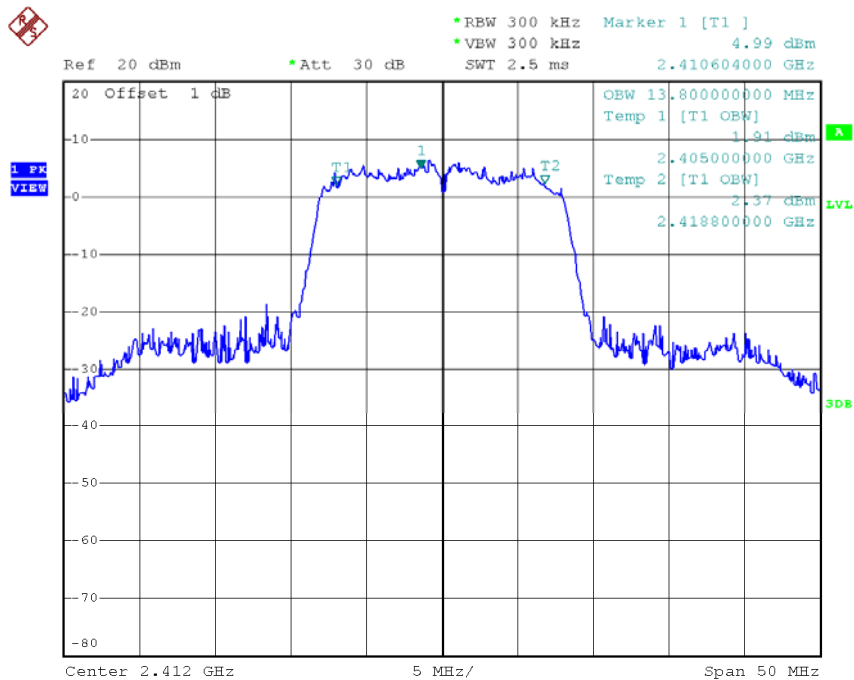

Date: 13.NOV.2015 18:17:38

High Voltage CH07 -99 % OBW

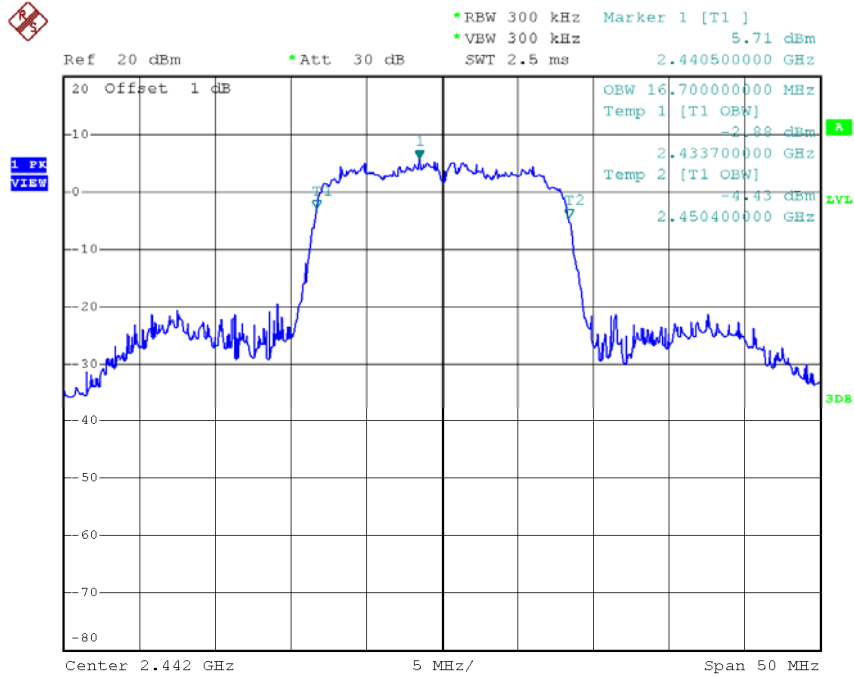

Date: 13.NOV.2015 18:46:03

High Voltage CH07 -90 % OBW

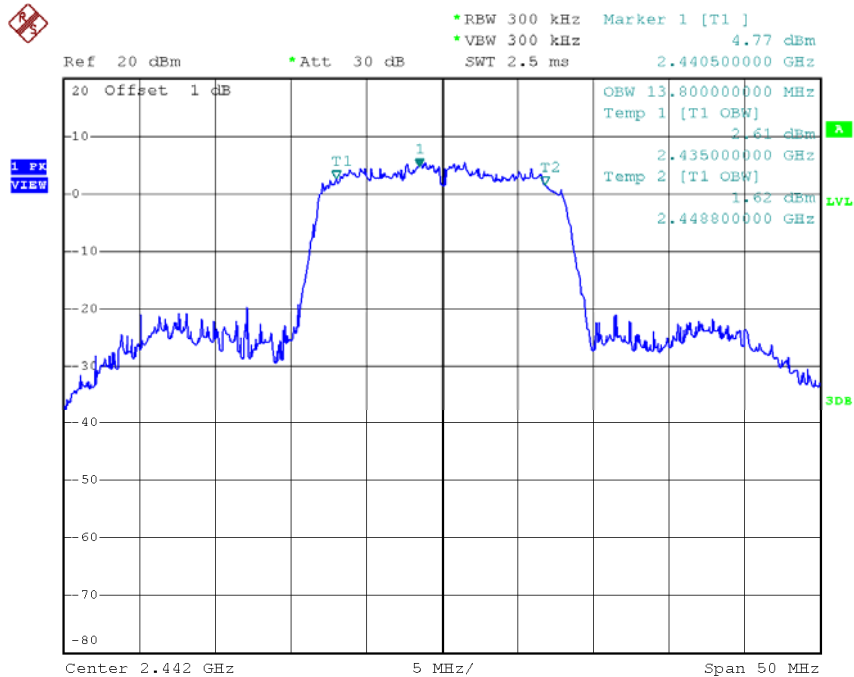

Date: 13.NOV.2015 18:45:55

High Voltage CH13 -99 % OBW

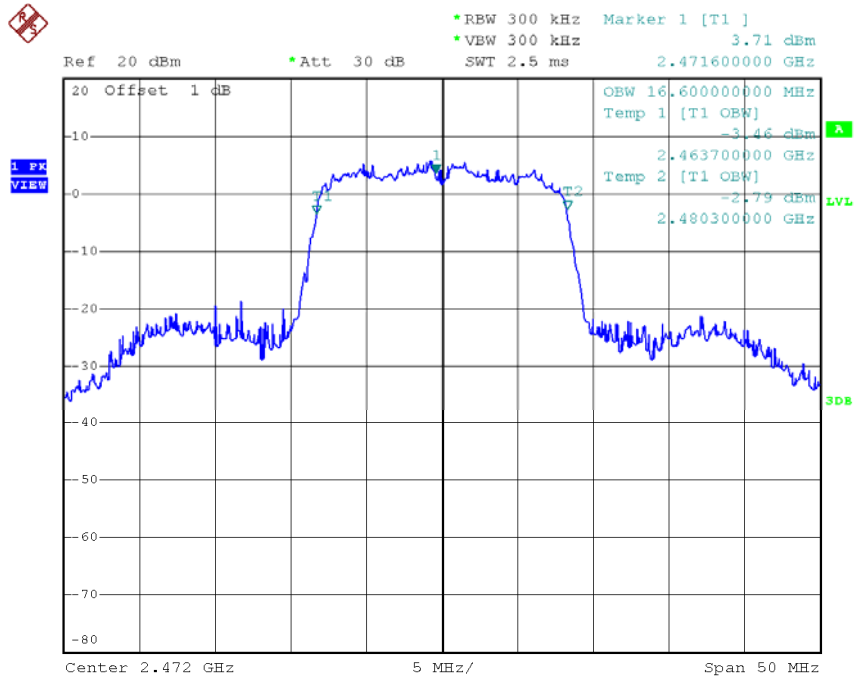

Date: 13.NOV.2015 19:06:56

High Voltage CH13 -90 % OBW

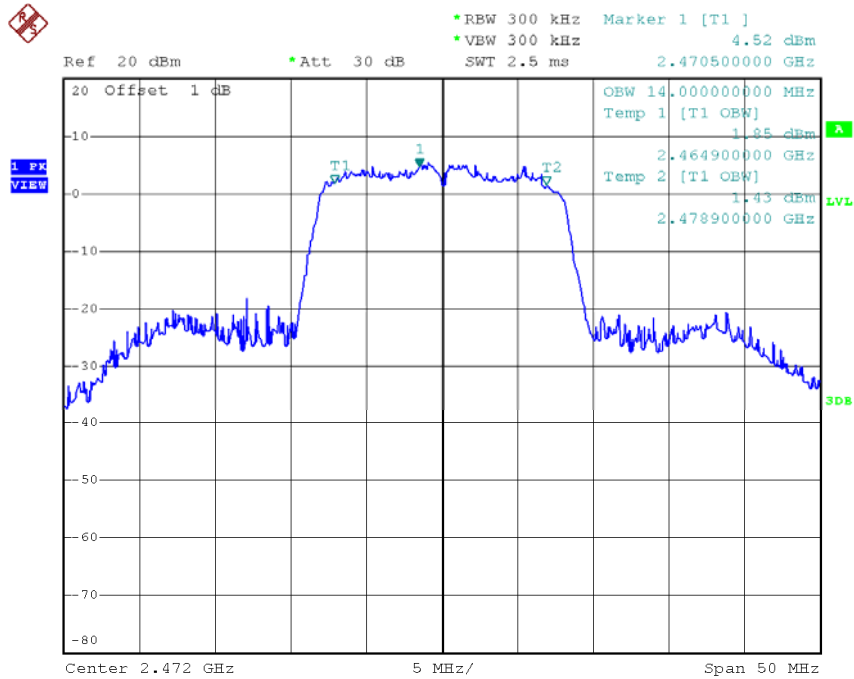

Date: 13.NOV.2015 19:06:48

Low Voltage CH01 -99 % OBW

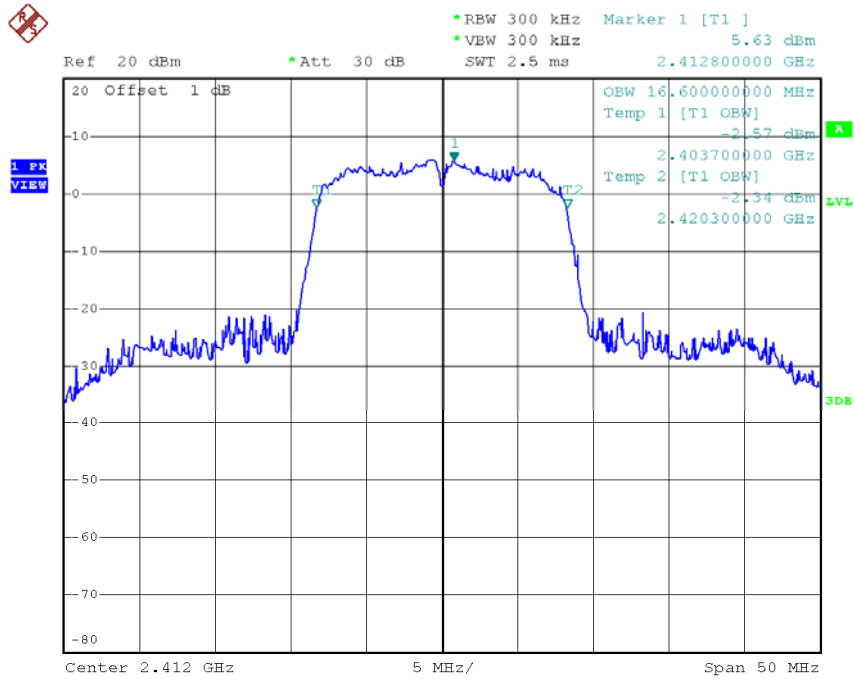

Date: 13.NOV.2015 18:20:51

Low Voltage CH01 -90 % OBW

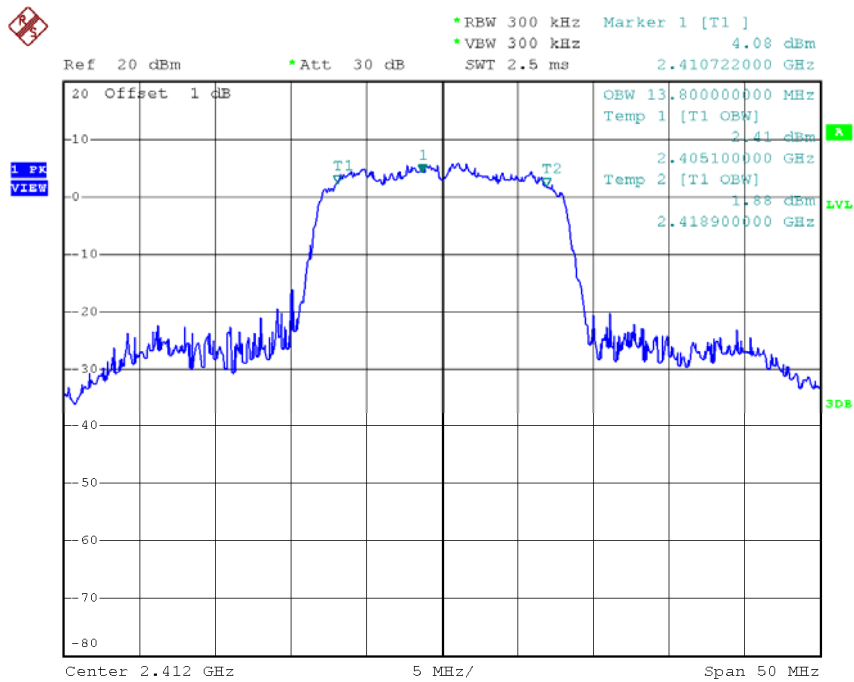

Date: 13.NOV.2015 18:20:43

Low Voltage CH07 -99 % OBW

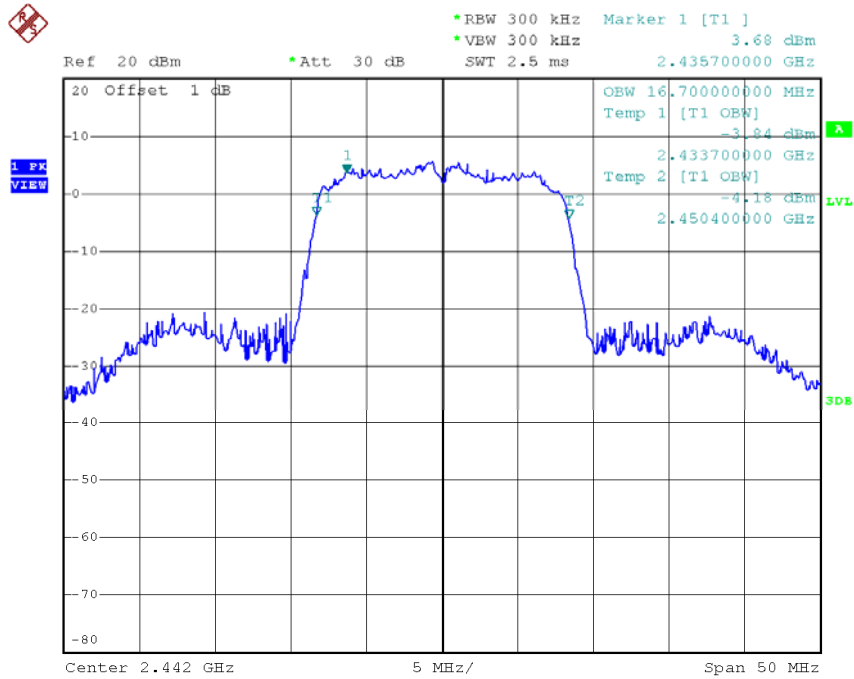

Date: 13.NOV.2015 18:53:26

Low Voltage CH07 -90 % OBW

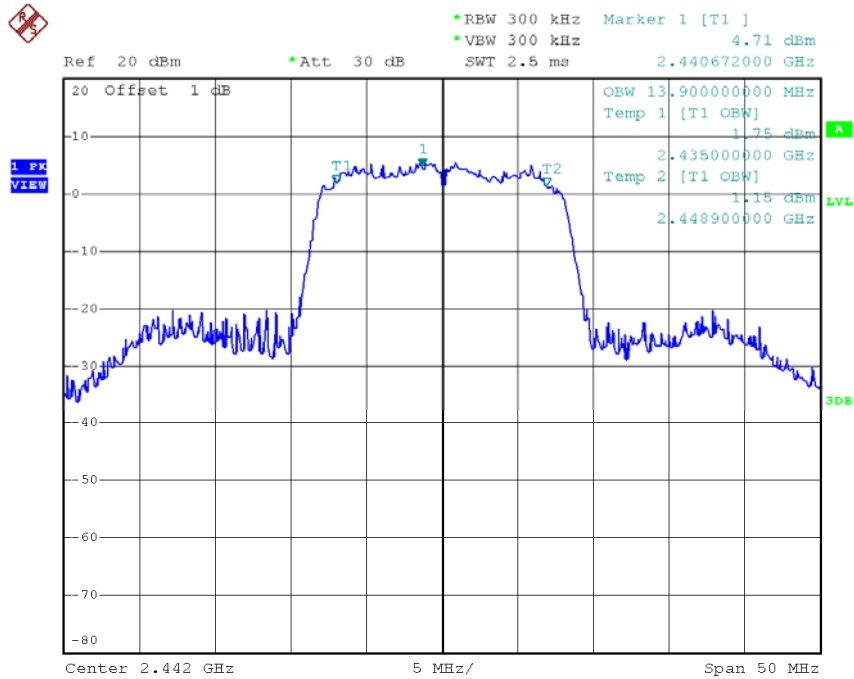

Date: 13.NOV.2015 18:53:18

Low Voltage CH13 -99 % OBW

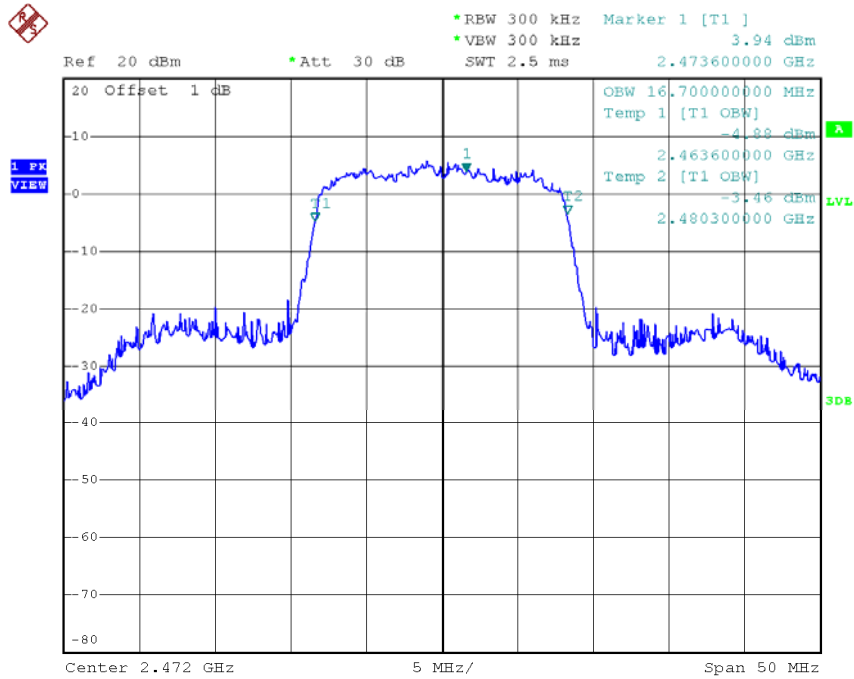

Date: 13.NOV.2015 19:13:02

Low Voltage CH13 -90 % OBW

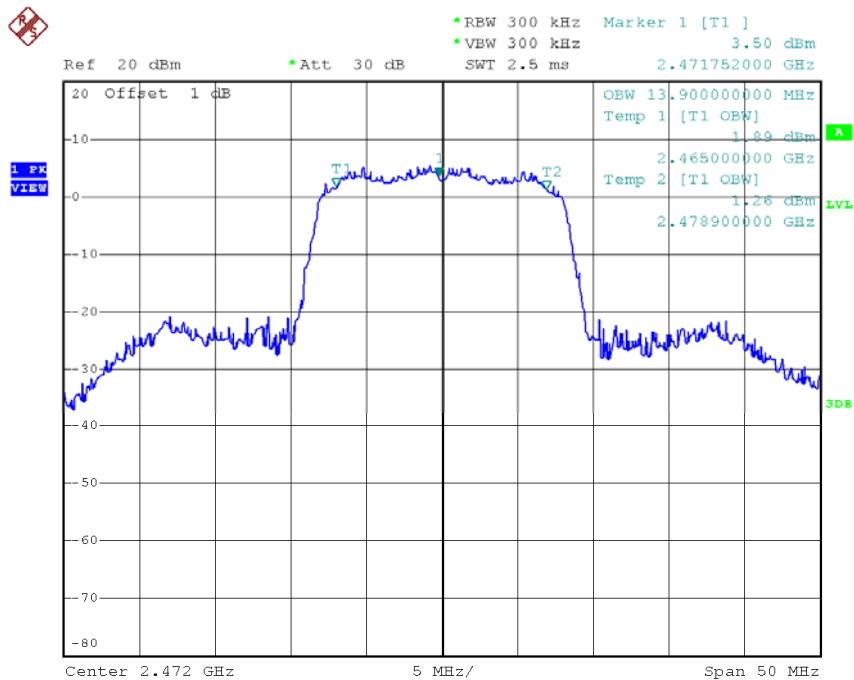

Date: 13.NOV.2015 19:12:54

Test Mode:	802.11n(HT20)/CH01,CH07,CH13
------------	------------------------------

Test Voltage (V)	Normal Voltage			Remarks
Test Frequency (MHz)	2412	2442	2472	Low/Mid/High of test frequency range
Occupied bandwidth (MHz)	17.70	17.60	17.60	Limit \leq 26 MHz (RBW/VBW : 300kHz)
Spreading Bandwidth (MHz)	14.70	14.70	14.60	\geq 500 kHz (FHSS, DSSS)
Spread-factor=Spreading Bandwidth/1.5	9.80	9.80	9.73	Spread Factor Limit \geq 5 (DSSS and FHSS)

Test Voltage (V)	High Voltage			Remarks
Test Frequency (MHz)	2412	2442	2472	Low/Mid/High of test frequency range
Occupied bandwidth (MHz)	17.60	17.60	17.60	Limit \leq 26 MHz (RBW/VBW : 300kHz)
Spreading Bandwidth (MHz)	14.70	14.60	14.80	\geq 500 kHz (FHSS, DSSS)
Spread-factor=Spreading Bandwidth/1.5	9.80	9.73	9.87	Spread Factor Limit \geq 5 (DSSS and FHSS)

Test Voltage (V)	Low Voltage			Remarks
Test Frequency (MHz)	2412	2442	2472	Low/Mid/High of test frequency range
Occupied bandwidth (MHz)	17.60	17.60	17.60	Limit \leq 26 MHz (RBW/VBW : 300kHz)
Spreading Bandwidth (MHz)	14.70	14.70	14.60	\geq 500 kHz (FHSS, DSSS)
Spread-factor=Spreading Bandwidth/1.5	9.80	9.80	9.73	Spread Factor Limit \geq 5 (DSSS and FHSS)

Note: 1. Spread Factor = Spread Bandwidth / TR
 (TR = 1.375 for 802.11b; TR = 1.5 for 802.11g / 802.11n (20M); TR = 3 for 802.11n (40M))

Normal Voltage CH01 -99 % OBW

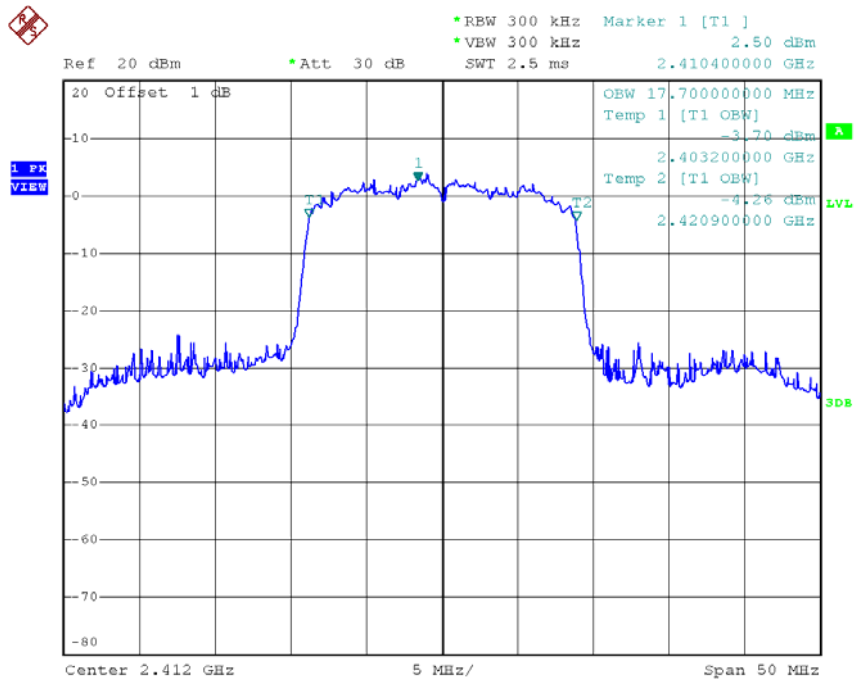

Date: 14.NOV.2015 13:08:38

Normal Voltage CH01 -90 % OBW

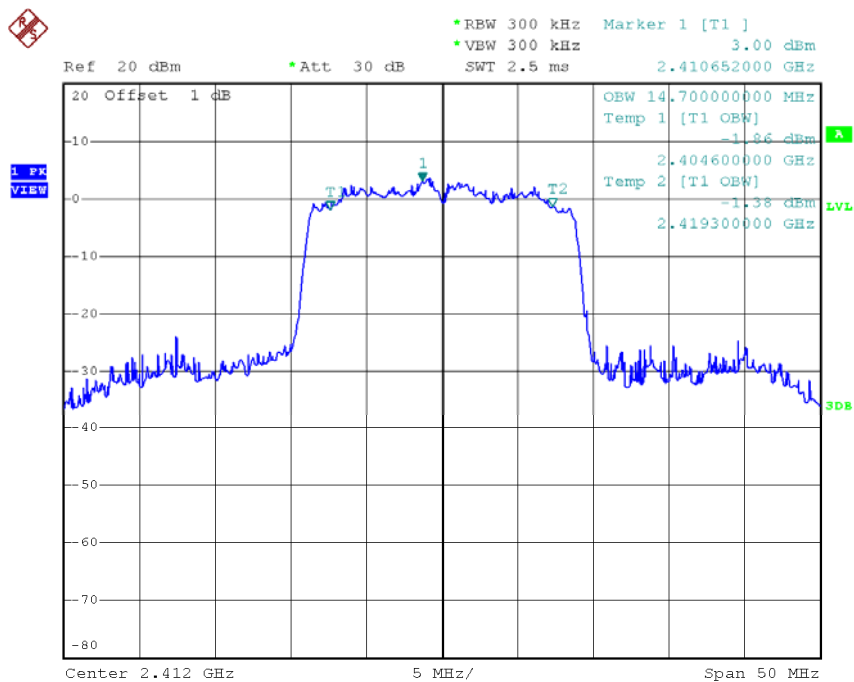

Date: 14.NOV.2015 13:08:30

Normal Voltage CH07 -99 % OBW

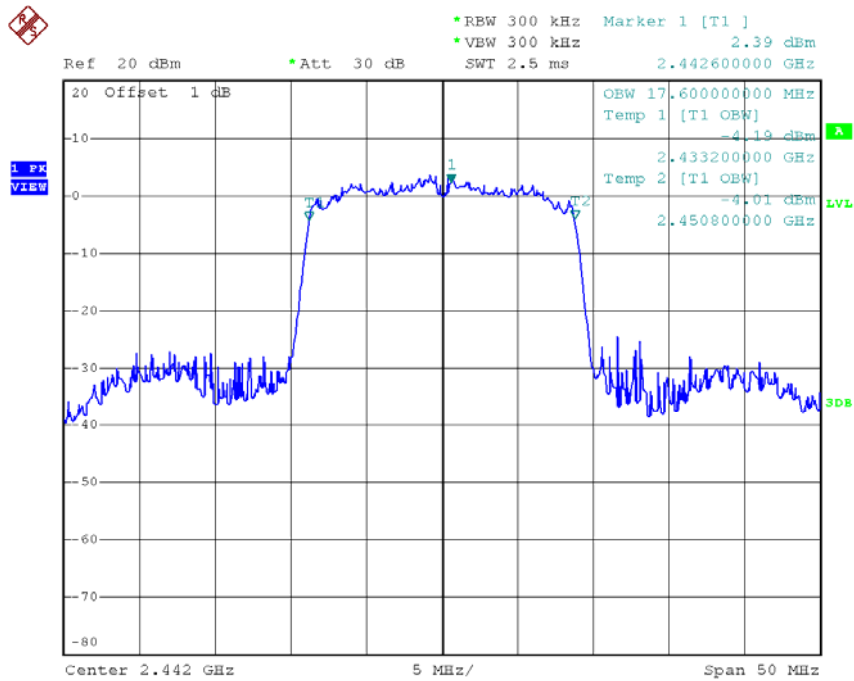

Date: 14.NOV.2015 13:32:56

Normal Voltage CH07 -90 % OBW

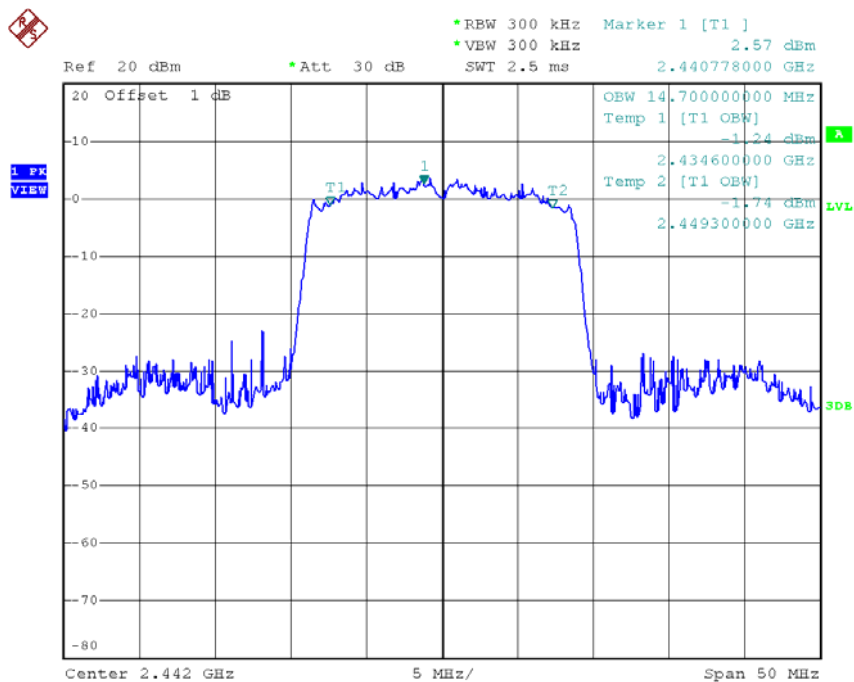

Date: 14.NOV.2015 13:32:48

Normal Voltage CH13 -99 % OBW

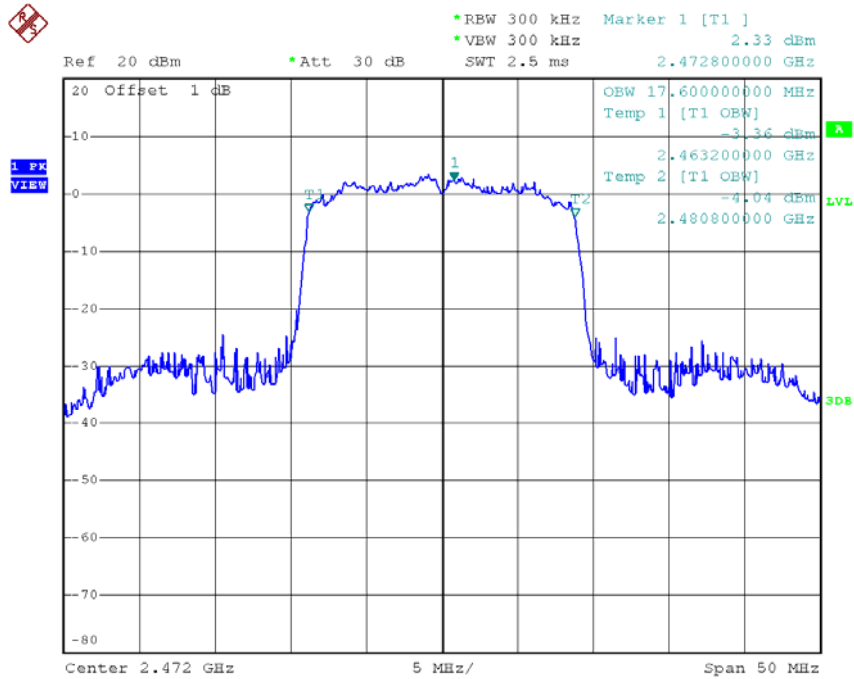

Date: 14.NOV.2015 13:47:25

Normal Voltage CH13 -90 % OBW

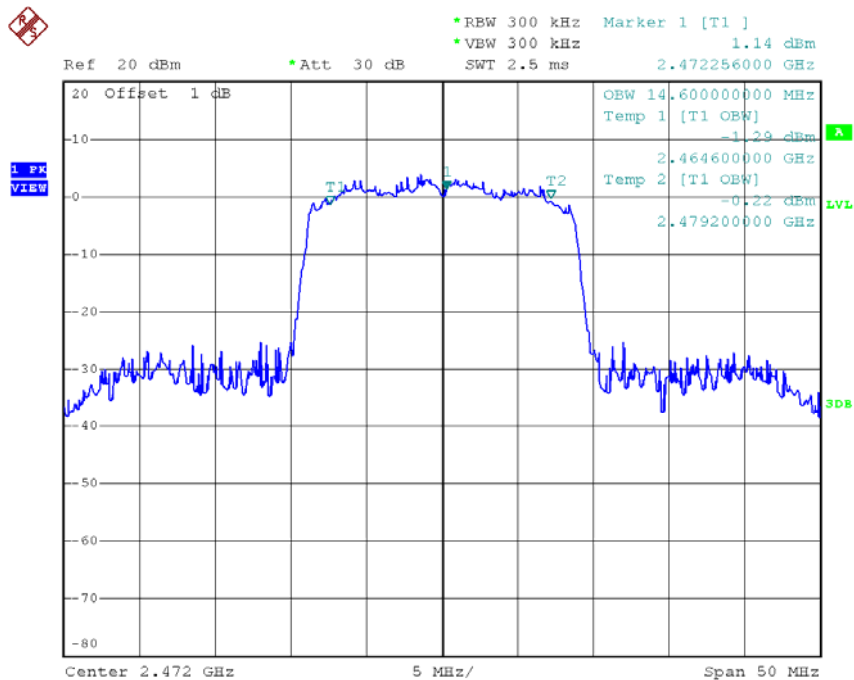

Date: 14.NOV.2015 13:47:17

High Voltage CH01 -99 % OBW

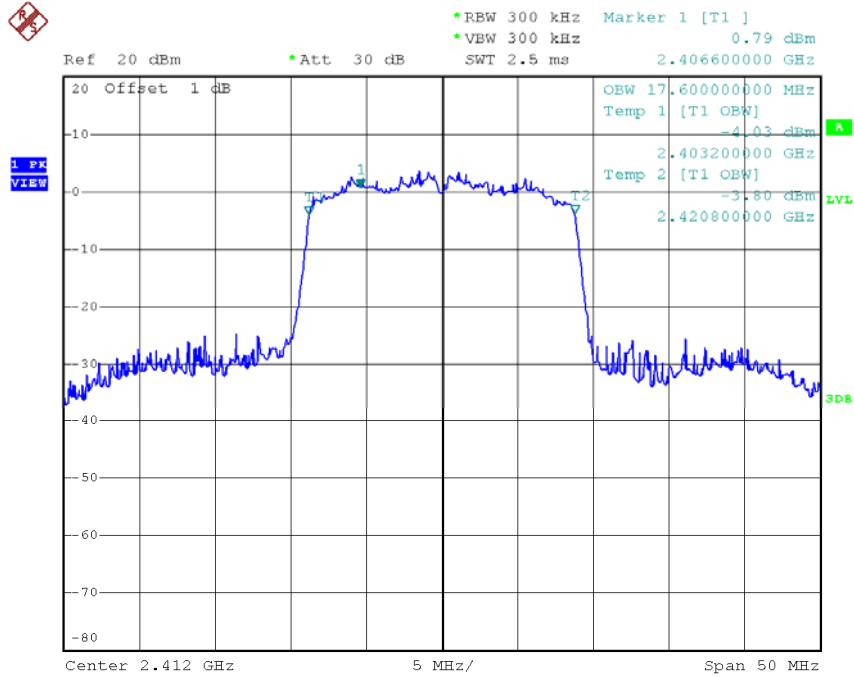

Date: 14.NOV.2015 13:01:22

High Voltage CH01 -90 % OBW

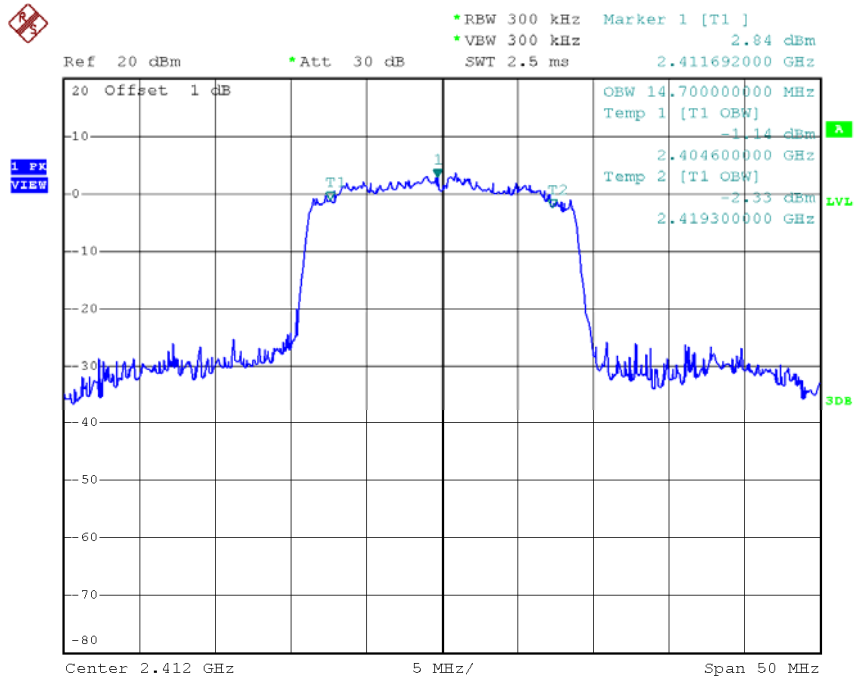

Date: 14.NOV.2015 13:01:15

High Voltage CH07 -99 % OBW

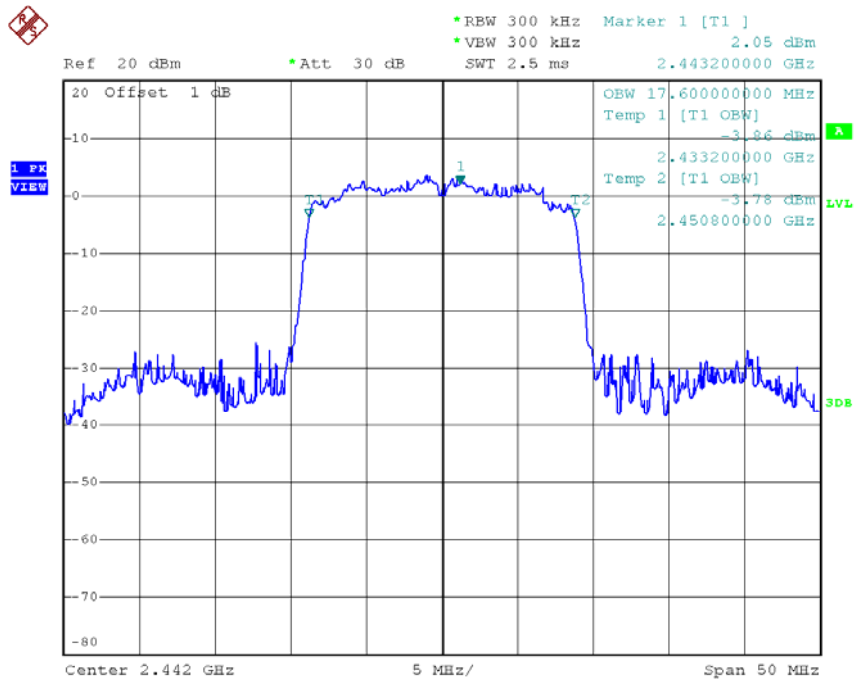

Date: 14.NOV.2015 13:29:17

High Voltage CH07 -90 % OBW

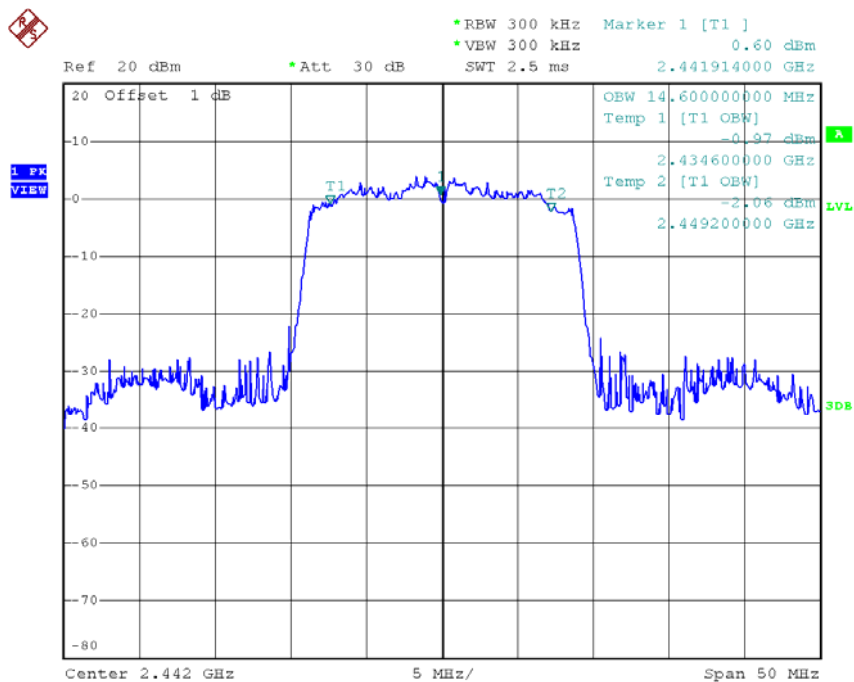

Date: 14.NOV.2015 13:29:09

High Voltage CH13 -99 % OBW

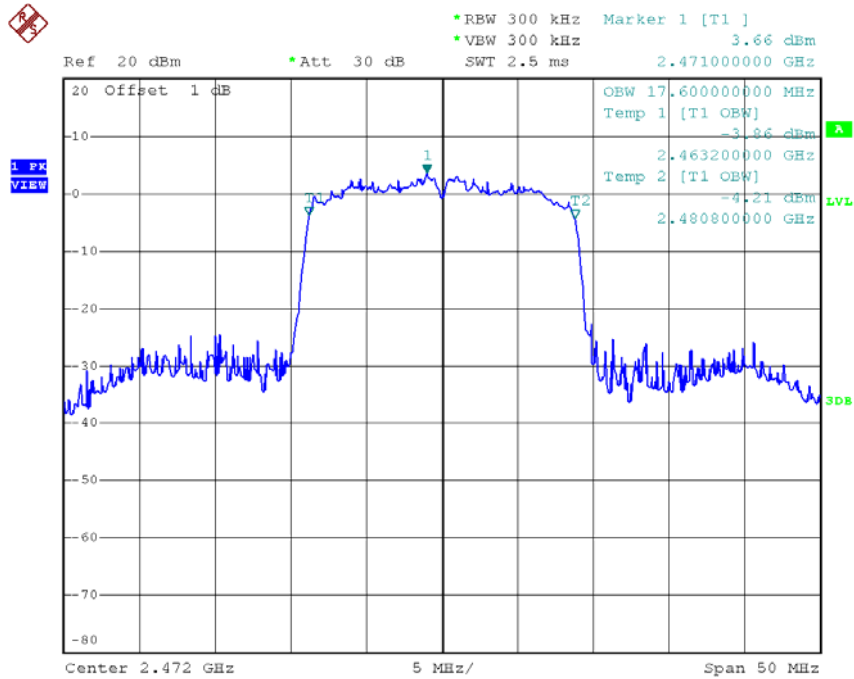

Date: 14.NOV.2015 13:44:41

High Voltage CH13 -90 % OBW

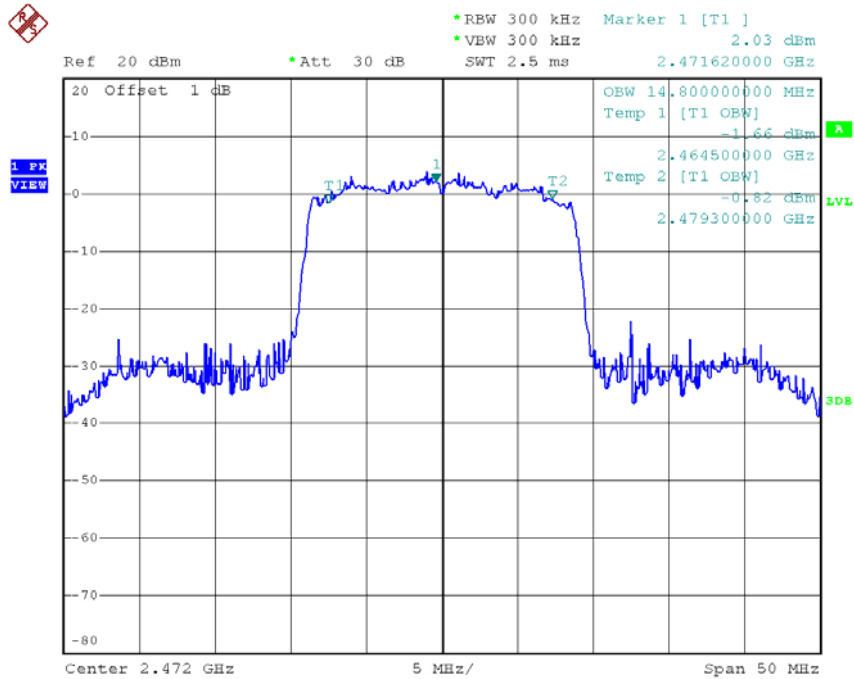

Date: 14.NOV.2015 13:44:33

Low Voltage CH01 -99 % OBW

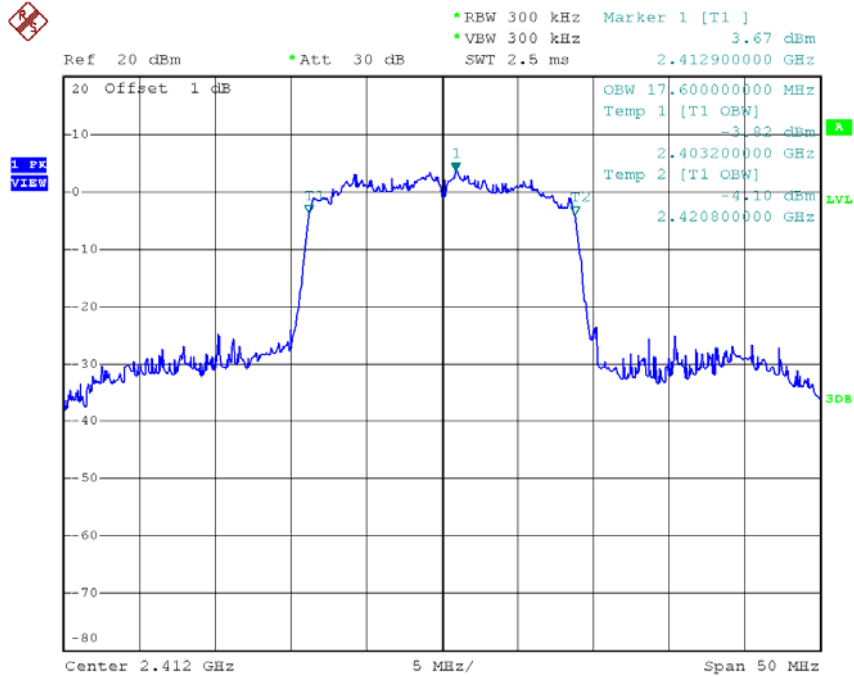

Date: 14.NOV.2015 13:16:14

Low Voltage CH01 -90 % OBW

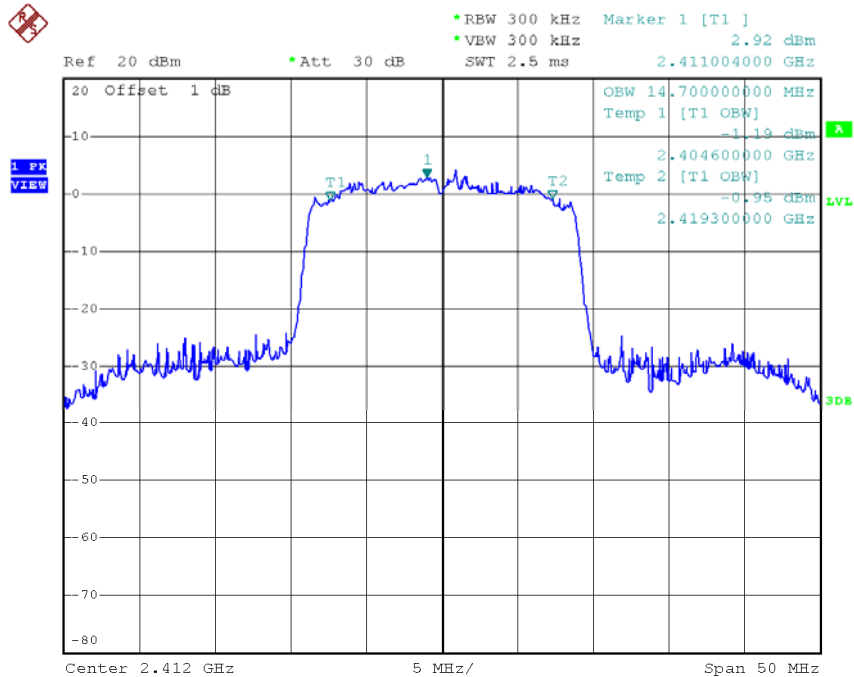

Date: 14.NOV.2015 13:16:07

Low Voltage CH07 -99 % OBW

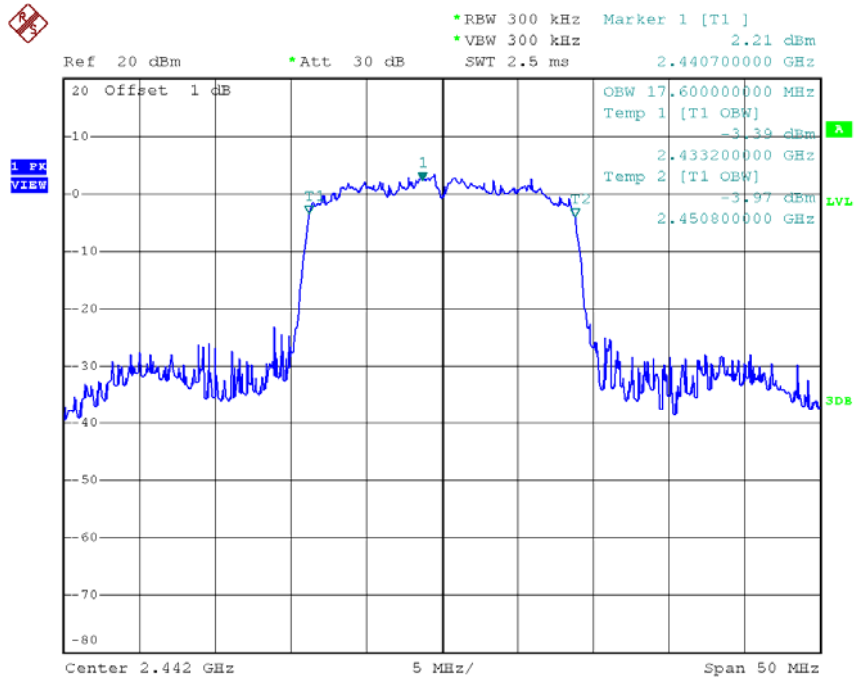

Date: 14.NOV.2015 13:36:12

Low Voltage CH07 -90 % OBW

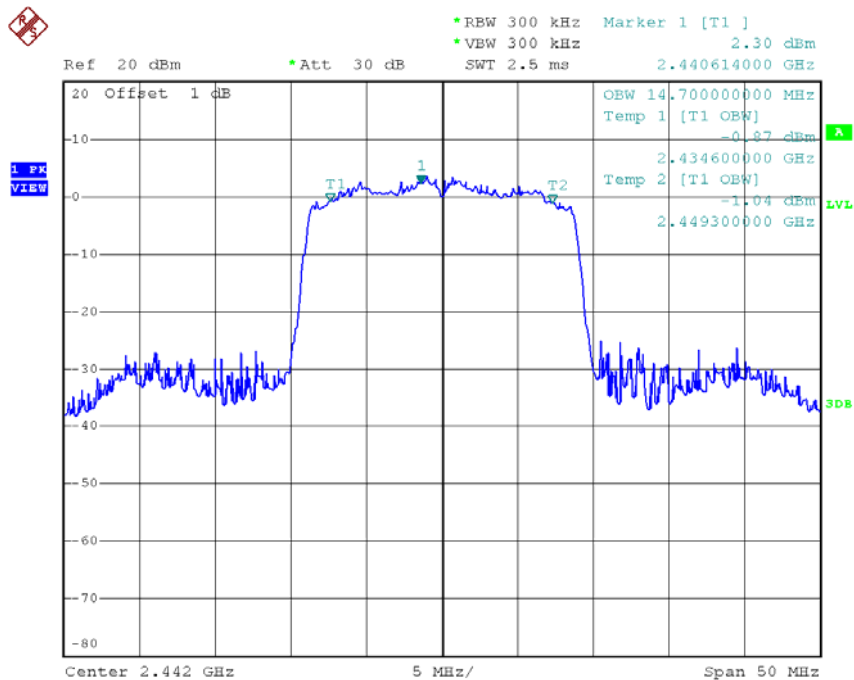

Date: 14.NOV.2015 13:36:04

Low Voltage CH13 -99 % OBW

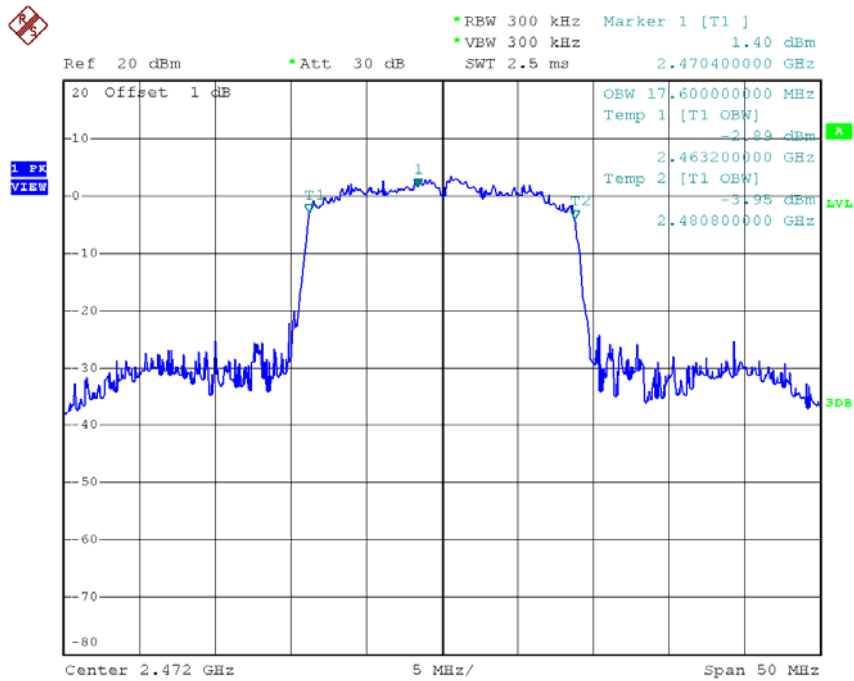

Date: 14.NOV.2015 14:00:06

Low Voltage CH13 -90 % OBW

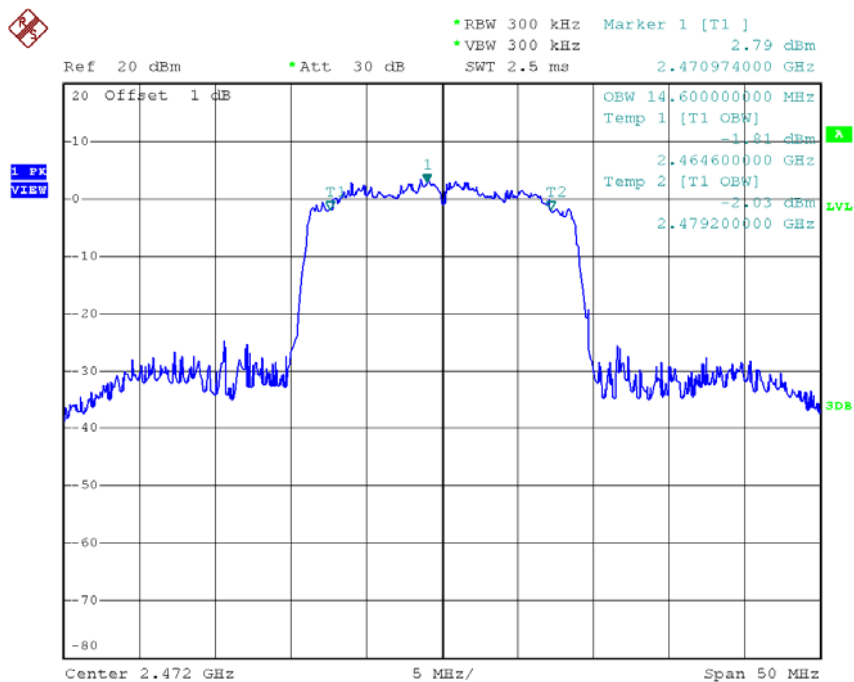

Date: 14.NOV.2015 13:59:58

ATTACHMENT C - UNWANTED EMISSION INTENSITY

For Chip antenna

Test Mode:	802.11b/CH01,CH07,CH13
------------	------------------------

Test Voltage		V	Normal Voltage			Remarks
Test Frequency		MHz	2412	2442	2472	Low/Mid/High of test frequency range
Unwanted Emission Intensity (Power emission within 1MHz bandwidth) (units: μW)	※ 1	μW/MHz	0.03936	0.04325	0.04920	Limit ≦ 2.5 μW/MHz (-26 dBm/MHz)
	※ 2	μW/MHz	0.08128	0.02924	0.03048	Limit ≦ 2.5 μW/MHz (-26 dBm/MHz)
	※ 3	μW/MHz	3.40408	0.03155	0.02109	Limit ≦ 25 μW/MHz (-16 dBm/MHz)
	※ 4	μW/MHz	0.00927	0.01387	6.98232	Limit ≦ 25 μW/MHz (-16 dBm/MHz)
	※ 5	μW/MHz	0.03090	0.03162	0.03162	Limit ≦ 2.5 μW/MHz (-26 dBm/MHz)

Test Voltage		V	High Voltage			Remarks
Test Frequency		MHz	2412	2442	2472	Low/Mid/High of test frequency range
Unwanted Emission Intensity (Power emission within 1MHz bandwidth) (units: μW)	※ 1	μW/MHz	0.03855	0.03846	0.04395	Limit ≦ 2.5 μW/MHz (-26 dBm/MHz)
	※ 2	μW/MHz	0.06950	0.02844	0.03020	Limit ≦ 2.5 μW/MHz (-26 dBm/MHz)
	※ 3	μW/MHz	4.18794	0.02992	0.01945	Limit ≦ 25 μW/MHz (-16 dBm/MHz)
	※ 4	μW/MHz	0.01079	0.01327	7.34514	Limit ≦ 25 μW/MHz (-16 dBm/MHz)
	※ 5	μW/MHz	0.02818	0.03027	0.03573	Limit ≦ 2.5 μW/MHz (-26 dBm/MHz)

Test Voltage		V	Low Voltage			Remarks
Test Frequency		MHz	2412	2442	2472	Low/Mid/High of test frequency range
Unwanted Emission Intensity (Power emission within 1MHz bandwidth) (units: μW)	※ 1	μW/MHz	0.05623	0.08995	0.06194	Limit ≦ 2.5 μW/MHz (-26 dBm/MHz)
	※ 2	μW/MHz	0.05260	0.03311	0.02679	Limit ≦ 2.5 μW/MHz (-26 dBm/MHz)
	※ 3	μW/MHz	3.54813	0.03034	0.01991	Limit ≦ 25 μW/MHz (-16 dBm/MHz)
	※ 4	μW/MHz	0.00845	0.01472	6.99842	Limit ≦ 25 μW/MHz (-16 dBm/MHz)
	※ 5	μW/MHz	0.03105	0.02582	0.03412	Limit ≦ 2.5 μW/MHz (-26 dBm/MHz)

Normal Voltage
CH01 Frequency Band 1 (30 MHz \leq f \leq 1000 MHz)

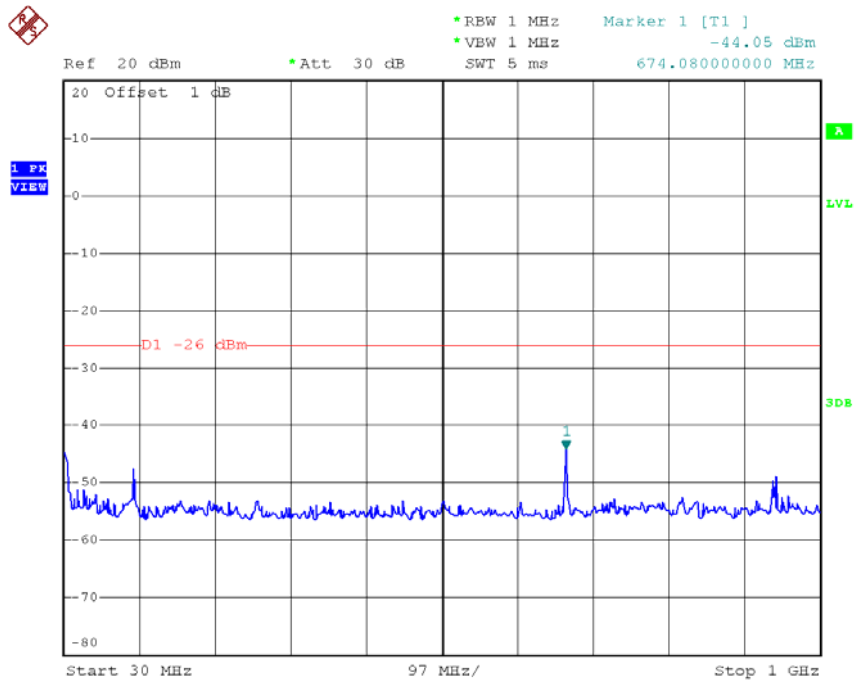

Date: 14.NOV.2015 15:22:29

Normal Voltage
CH01 Frequency Band 2 (1000 MHz < f \leq 2387 MHz)

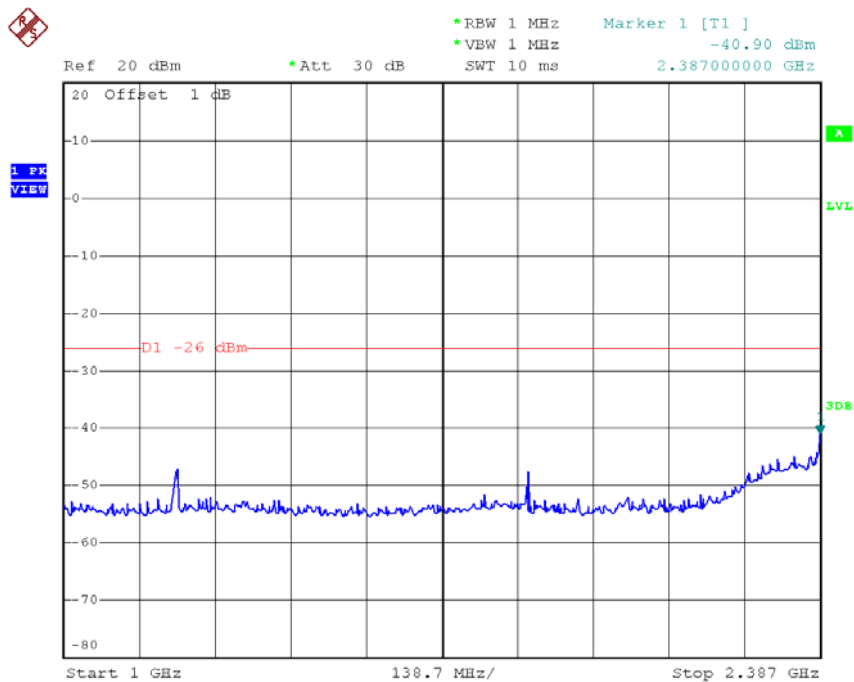

Date: 14.NOV.2015 15:22:40

Normal Voltage
CH01 Frequency Band 3 (2387 MHz \cong f < 2400 MHz)

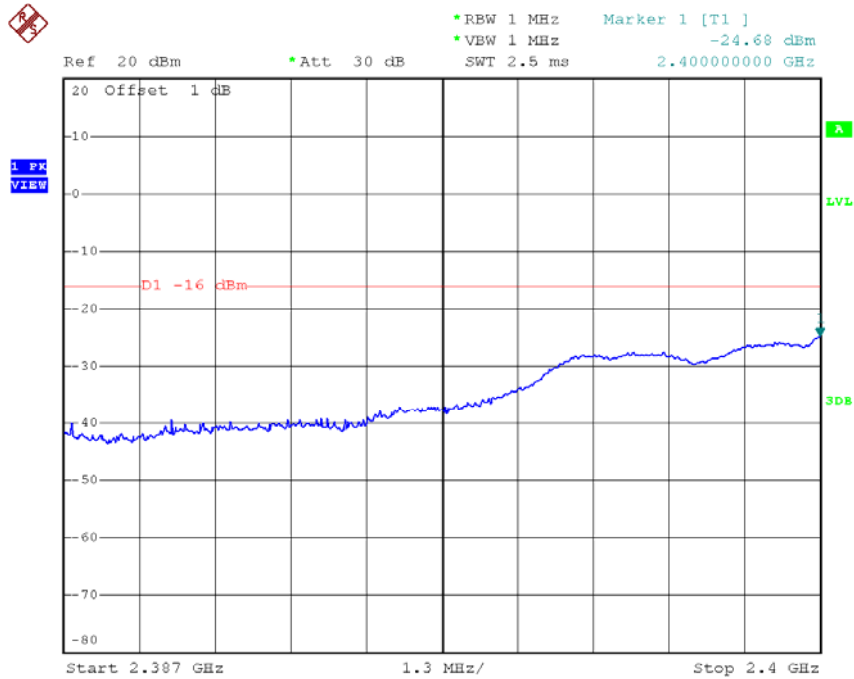

Date: 14.NOV.2015 15:22:51

Normal Voltage
CH01 Frequency Band 4 (2483.5 MHz \cong f < 2496.5 MHz)

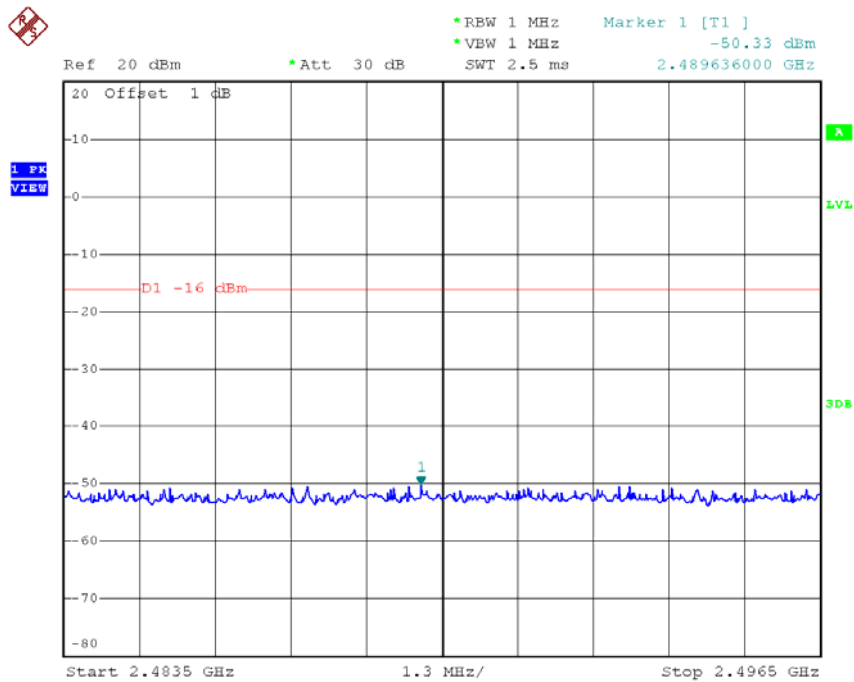

Date: 14.NOV.2015 15:23:01

Normal Voltage
CH01 Frequency Band 5 (2496.5 MHz \leq f < 12.5 GHz)

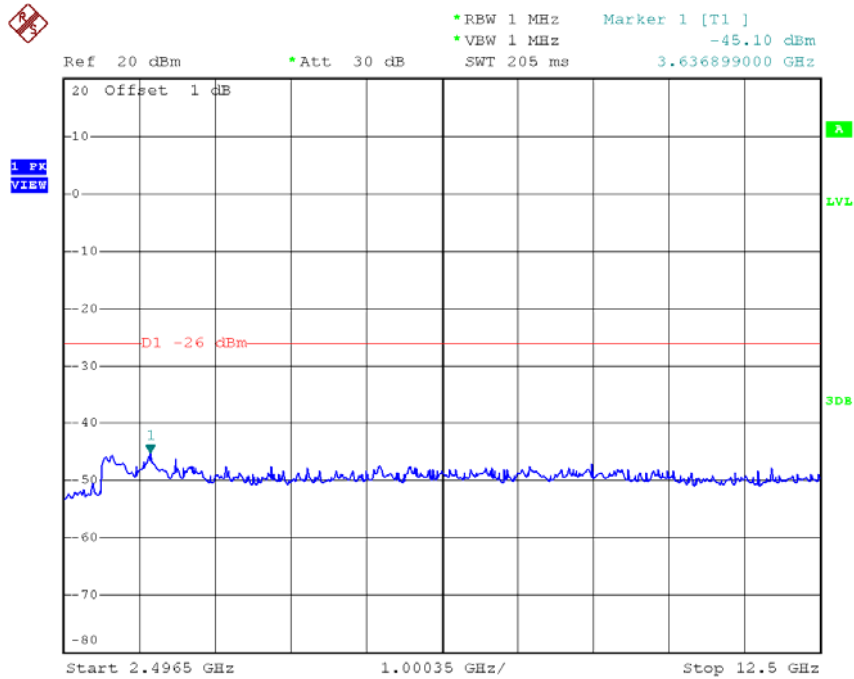

Date: 14.NOV.2015 15:23:11

Normal Voltage
CH07 Frequency Band 1 (30 MHz \leq f \leq 1000 MHz)

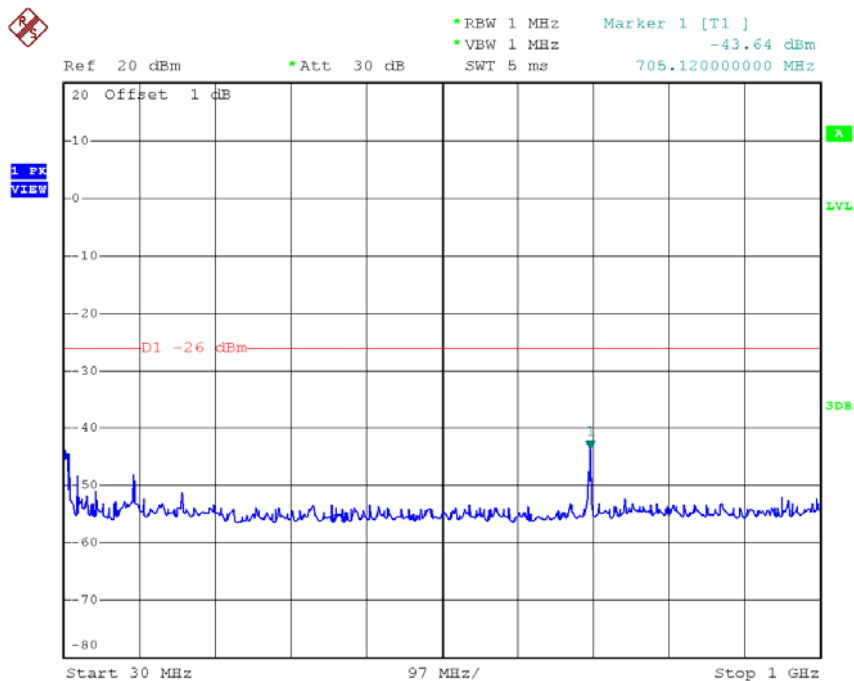

Date: 14.NOV.2015 15:40:17

Normal Voltage
CH07 Frequency Band 2 (1000 MHz < f ≤ 2387 MHz)

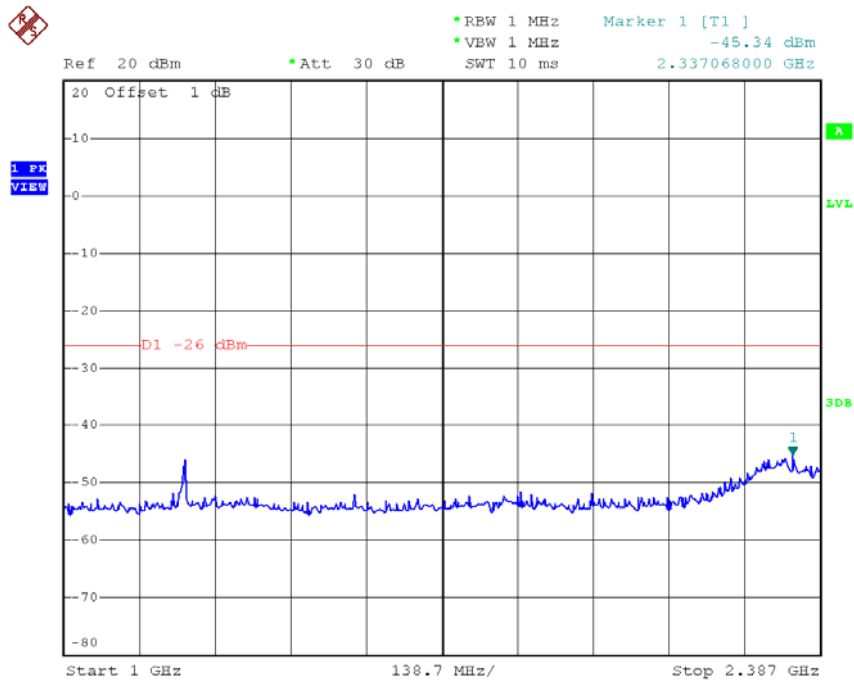

Date: 14.NOV.2015 15:40:27

Normal Voltage
CH07 Frequency Band 3 (2387 MHz ≤ f < 2400 MHz)

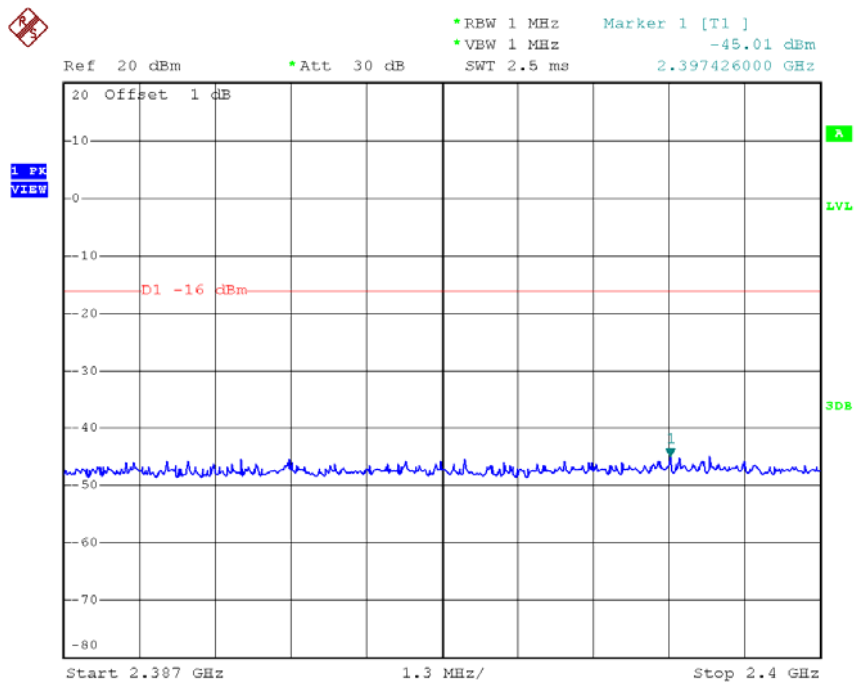

Date: 14.NOV.2015 15:40:38

Normal Voltage

CH07 Frequency Band 4 (2483.5 MHz \cong f < 2496.5 MHz)

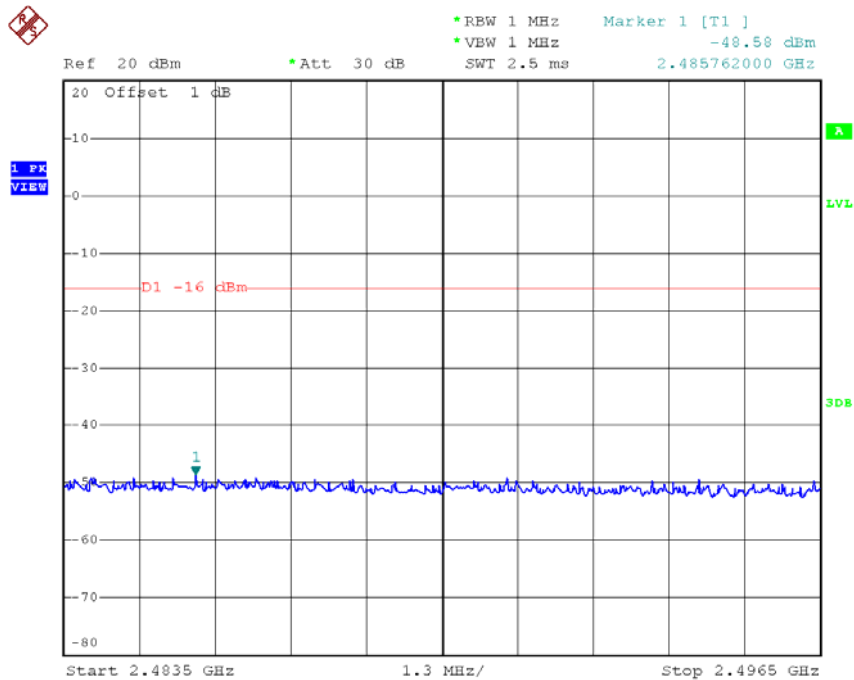

Date: 14.NOV.2015 15:40:48

Normal Voltage

CH07 Frequency Band 5 (2496.5 MHz \cong f < 12.5 GHz)

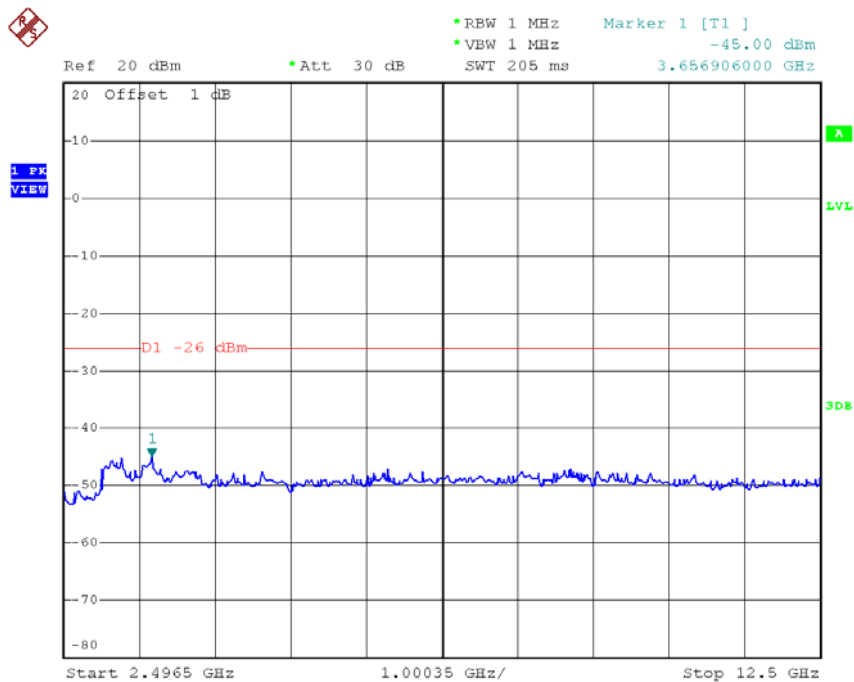

Date: 14.NOV.2015 15:40:59

Normal Voltage CH13 Frequency Band 1 (30 MHz \leq f \leq 1000 MHz)

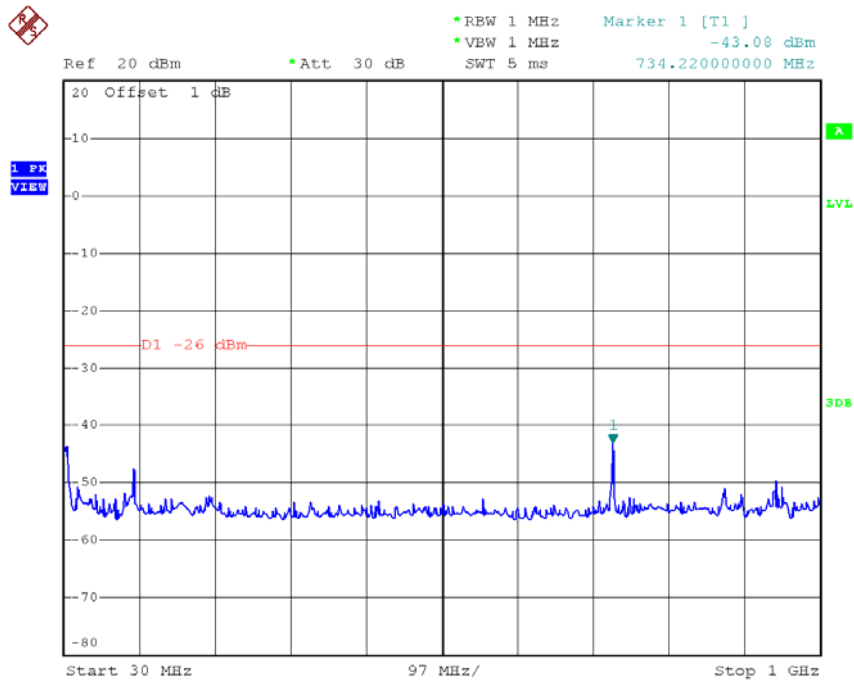

Date: 14.NOV.2015 16:17:00

Normal Voltage CH13 Frequency Band 2 (1000 MHz < f \leq 2387 MHz)

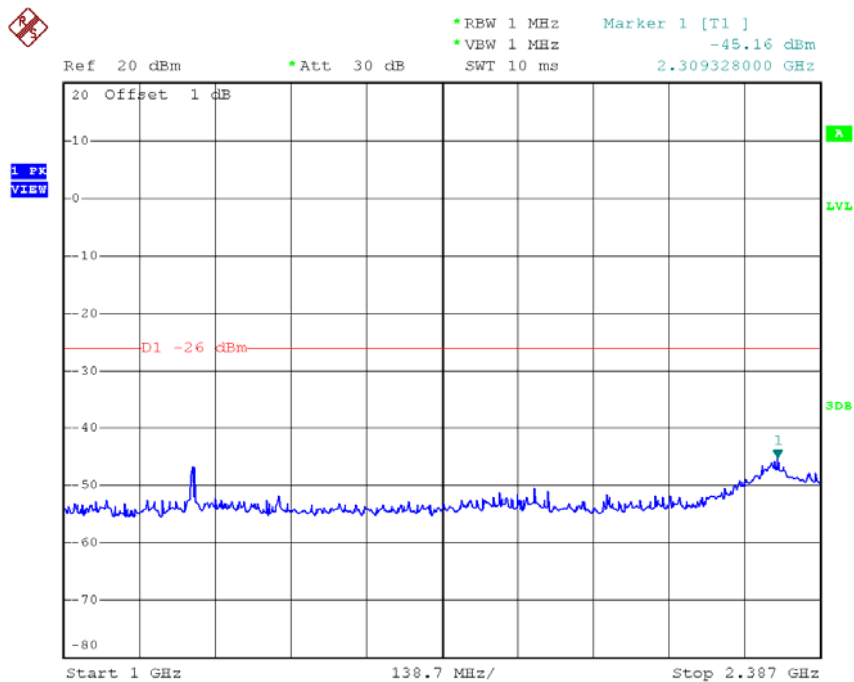

Date: 14.NOV.2015 16:17:11

Normal Voltage
CH13 Frequency Band 3 (2387 MHz \cong f < 2400 MHz)

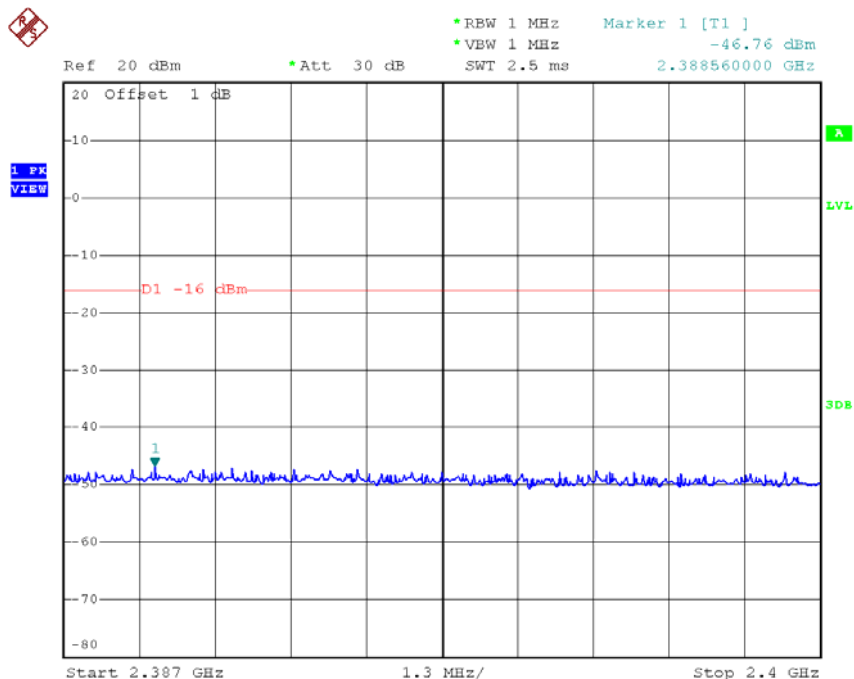

Date: 14.NOV.2015 16:17:22

Normal Voltage
CH13 Frequency Band 4 (2483.5 MHz \cong f < 2496.5 MHz)

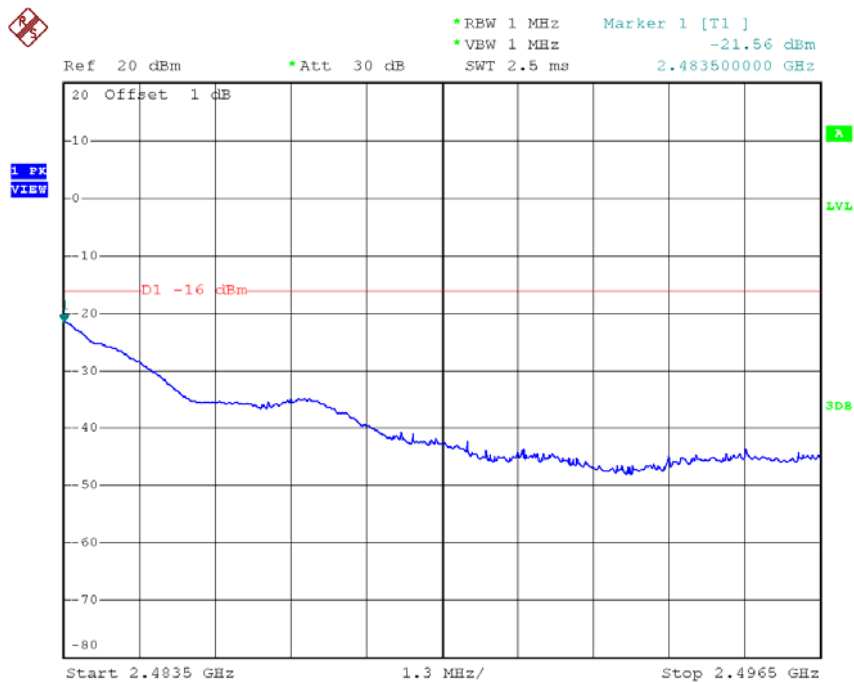

Date: 14.NOV.2015 16:17:31

Normal Voltage CH13 Frequency Band 5 (2496.5 MHz \cong f < 12.5 GHz)

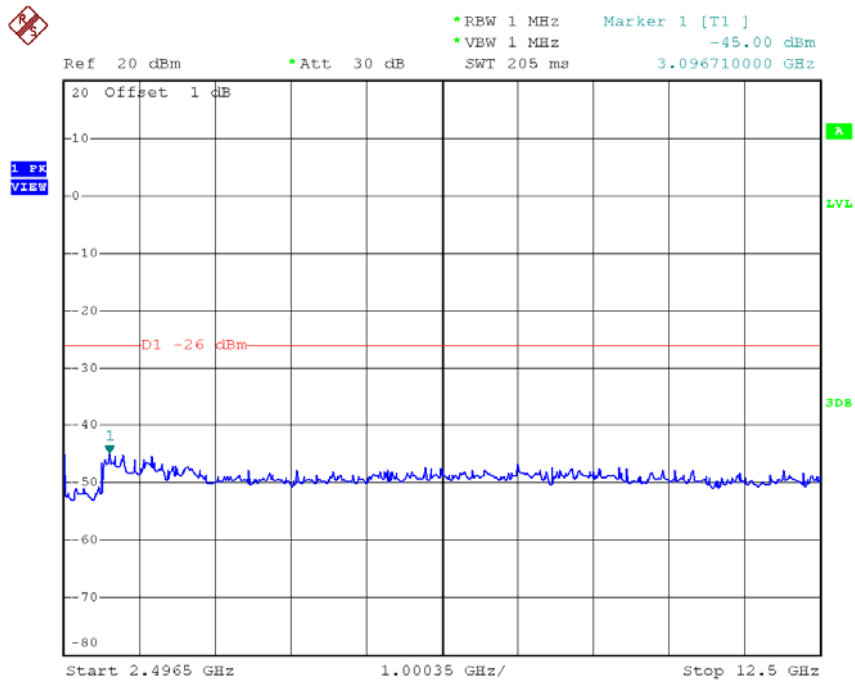

Date: 14.NOV.2015 16:17:42

High Voltage

CH01 Frequency Band 1 (30 MHz \leq f \leq 1000 MHz)

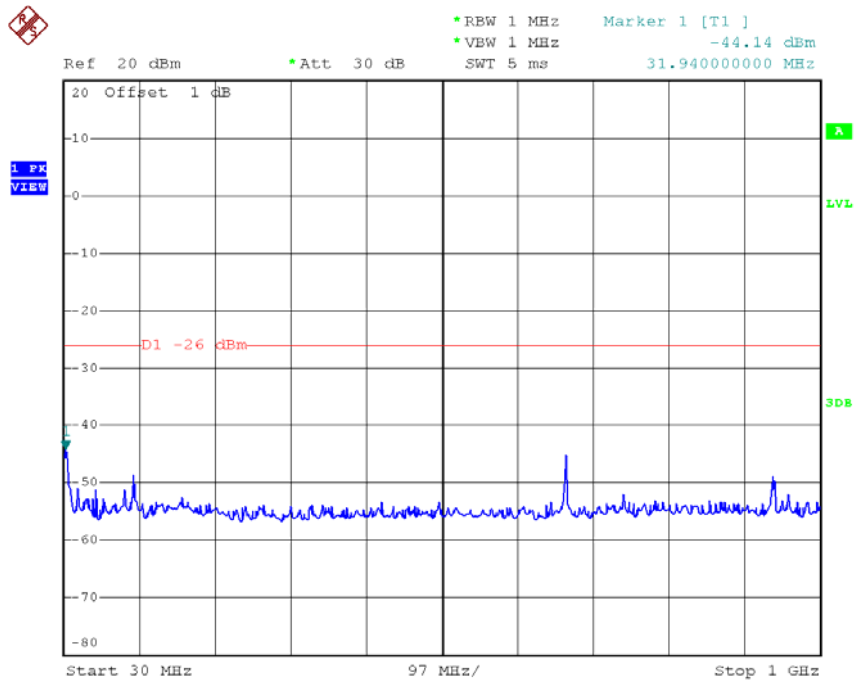

Date: 14.NOV.2015 15:23:49

High Voltage

CH01 Frequency Band 2 (1000 MHz < f \leq 2387 MHz)

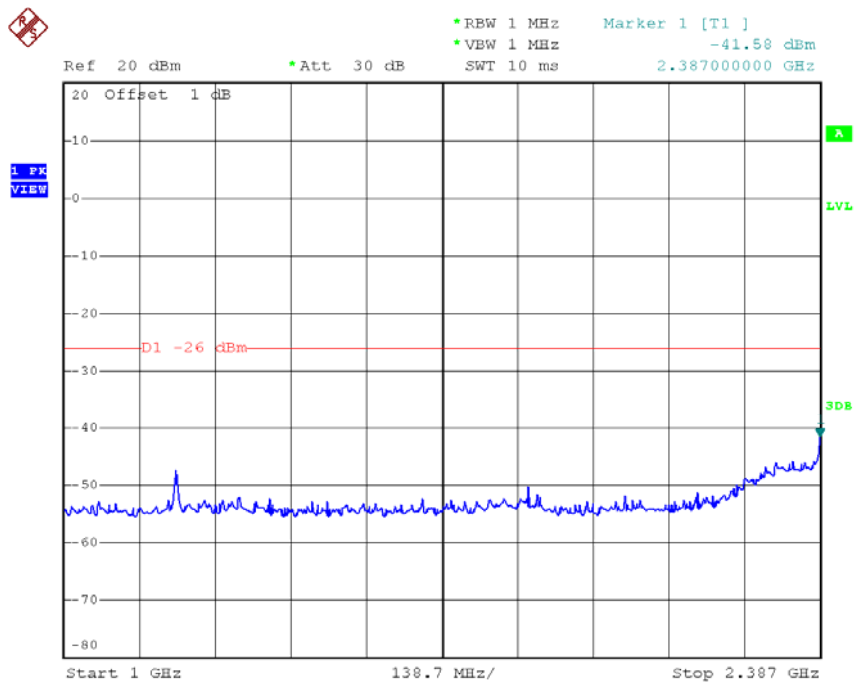

Date: 14.NOV.2015 15:24:00

High Voltage CH01 Frequency Band 3 (2387 MHz \cong f < 2400 MHz)

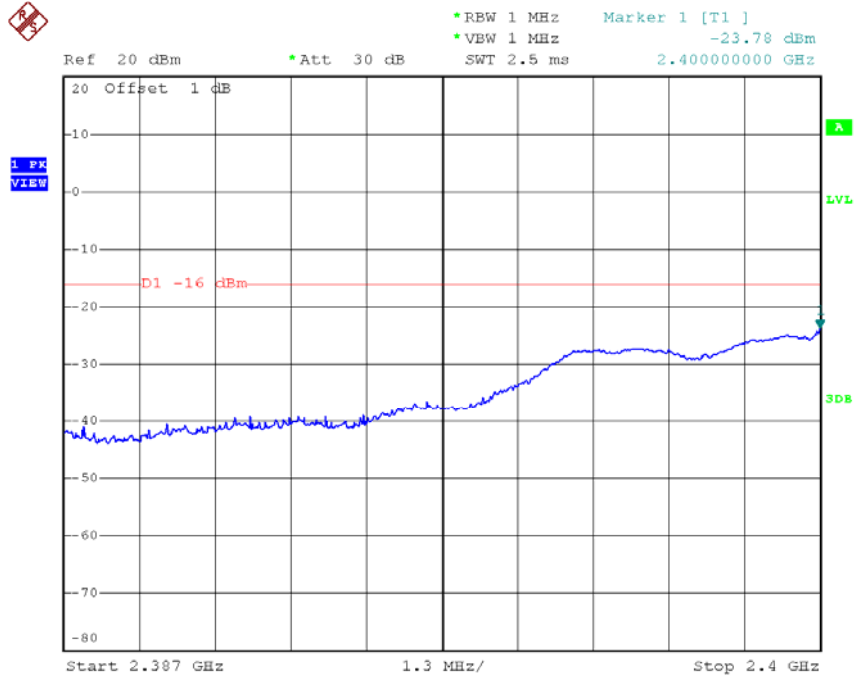

Date: 14.NOV.2015 15:24:10

High Voltage CH01 Frequency Band 4 (2483.5 MHz \cong f < 2496.5 MHz)

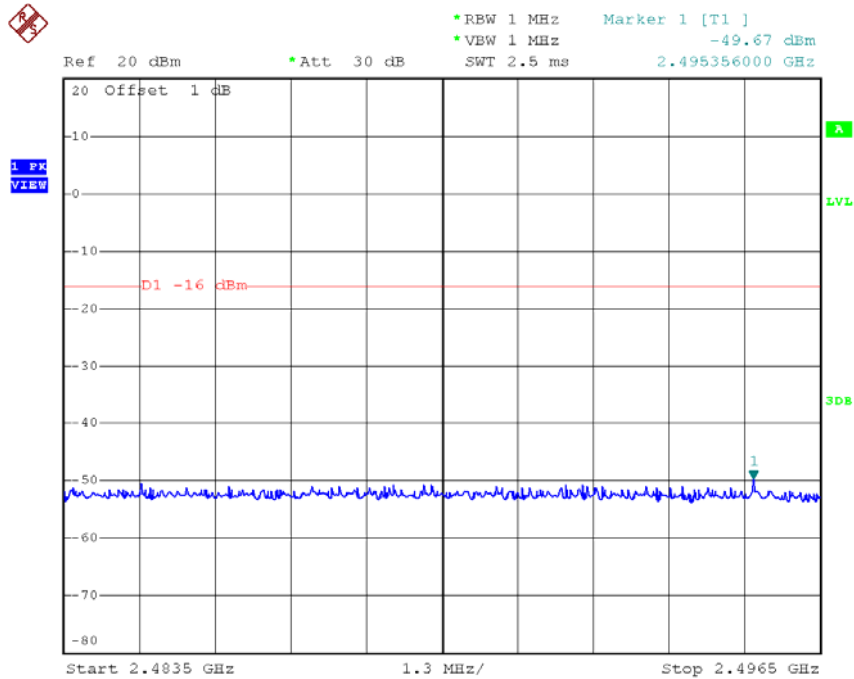

Date: 14.NOV.2015 15:24:20

High Voltage CH01 Frequency Band 5 (2496.5 MHz \leq f < 12.5 GHz)

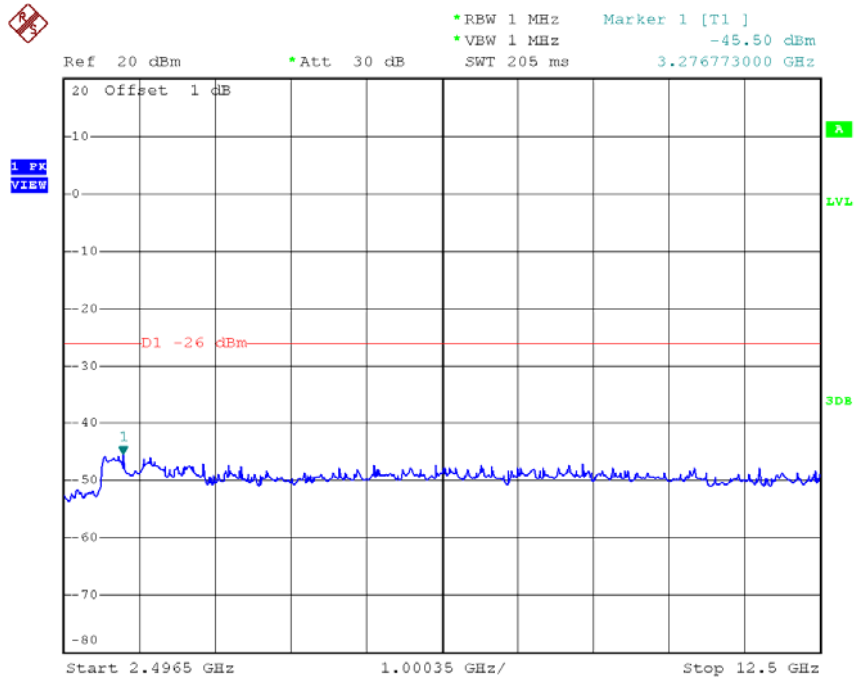

Date: 14.NOV.2015 15:24:31

High Voltage CH07 Frequency Band 1 (30 MHz \leq f \leq 1000 MHz)

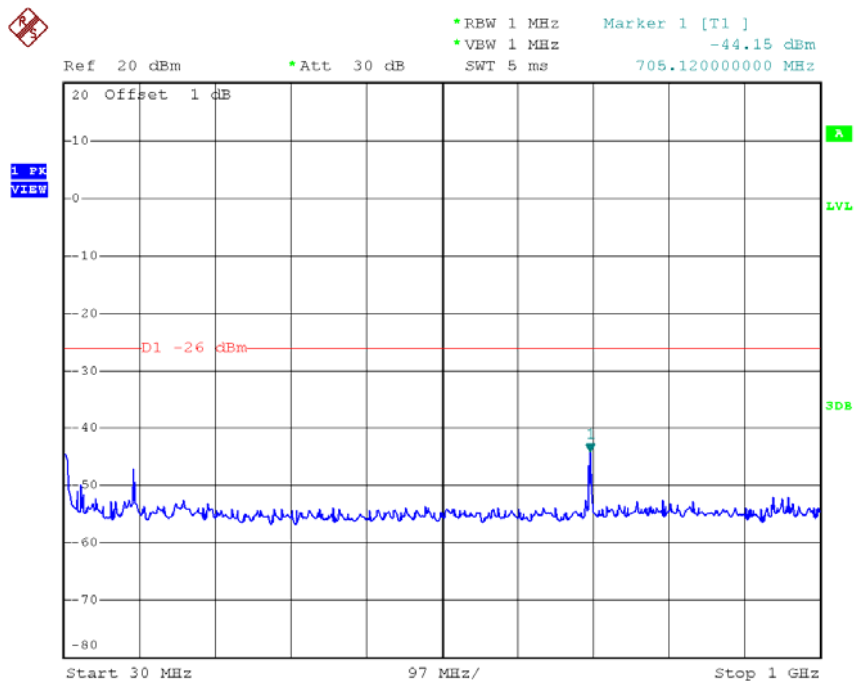

Date: 14.NOV.2015 15:37:04

High Voltage

CH07 Frequency Band 2 (1000 MHz < f ≤ 2387 MHz)

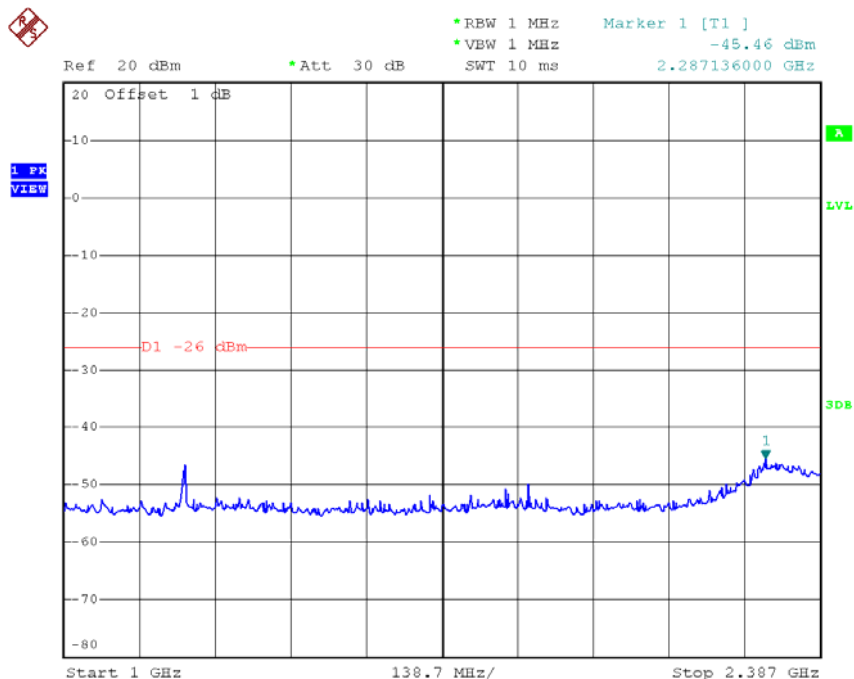

Date: 14.NOV.2015 15:37:15

High Voltage

CH07 Frequency Band 3 (2387 MHz ≤ f < 2400 MHz)

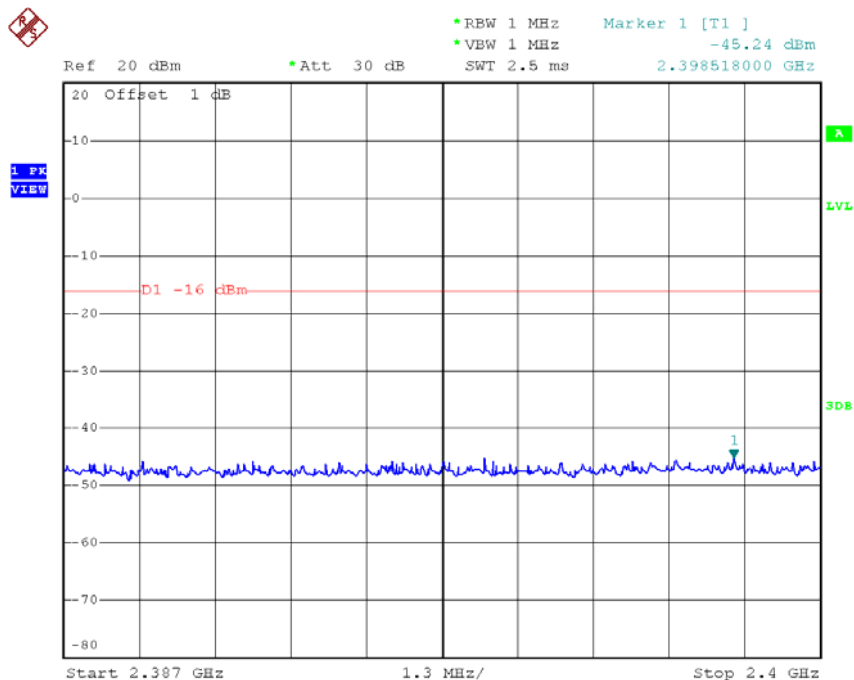

Date: 14.NOV.2015 15:37:26

High Voltage

CH07 Frequency Band 4 (2483.5 MHz \cong f < 2496.5 MHz)

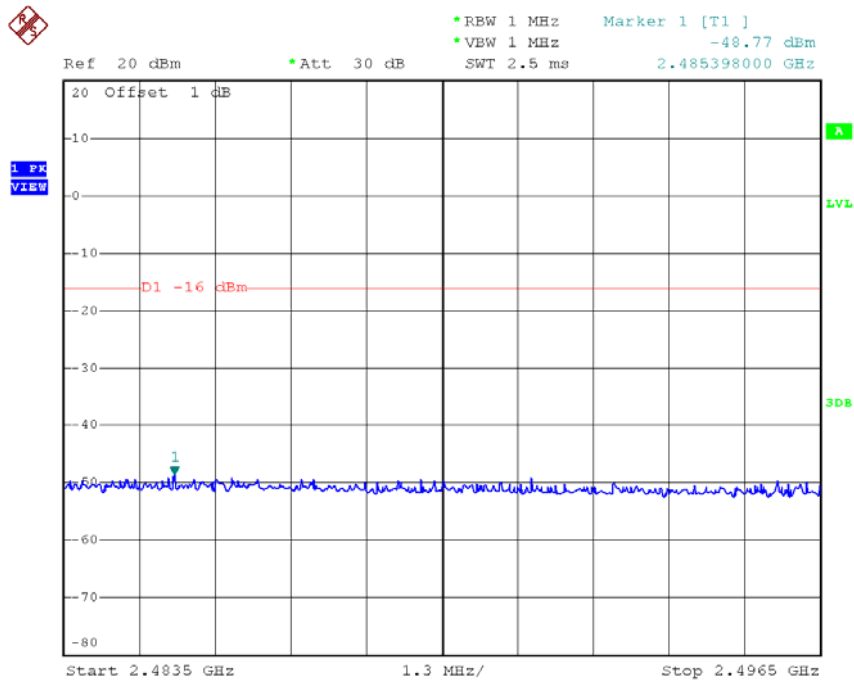

Date: 14.NOV.2015 15:37:35

High Voltage

CH07 Frequency Band 5 (2496.5 MHz \cong f < 12.5 GHz)

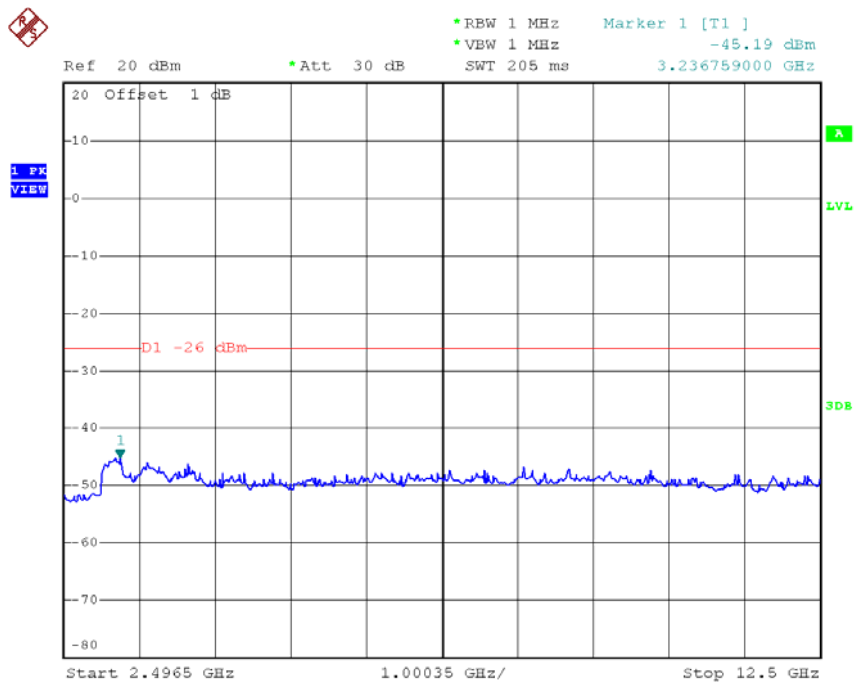

Date: 14.NOV.2015 15:37:46

High Voltage

CH13 Frequency Band 1 (30 MHz \leq f \leq 1000 MHz)

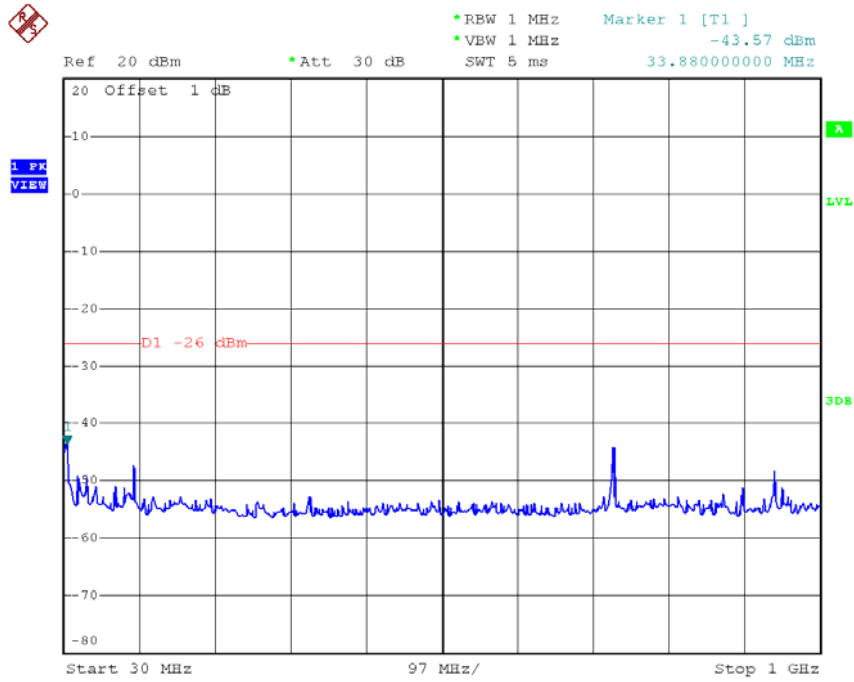

Date: 14.NOV.2015 16:12:56

High Voltage

CH13 Frequency Band 2 (1000 MHz < f \leq 2387 MHz)

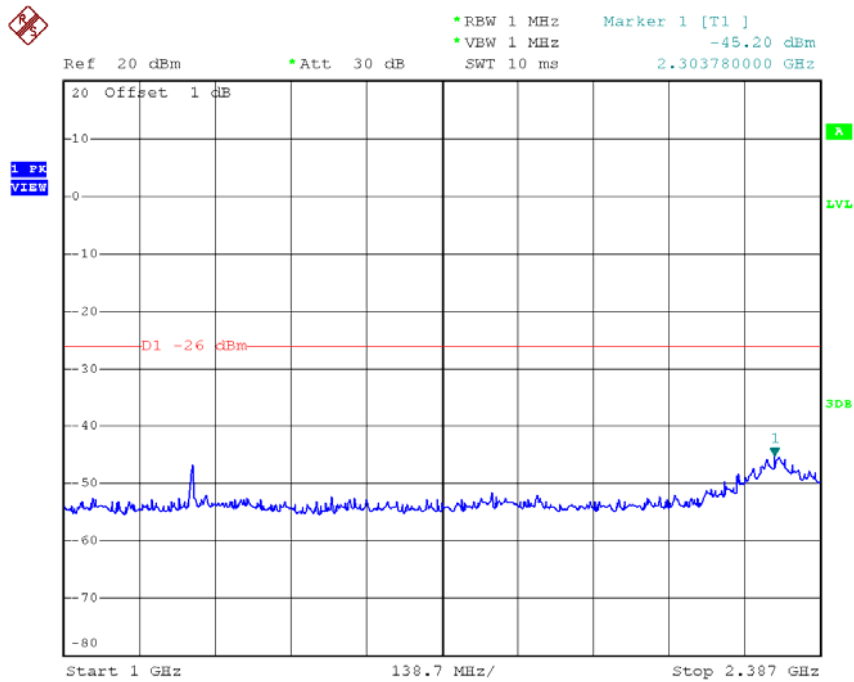

Date: 14.NOV.2015 16:13:08

High Voltage CH13 Frequency Band 3 (2387 MHz \cong f < 2400 MHz)

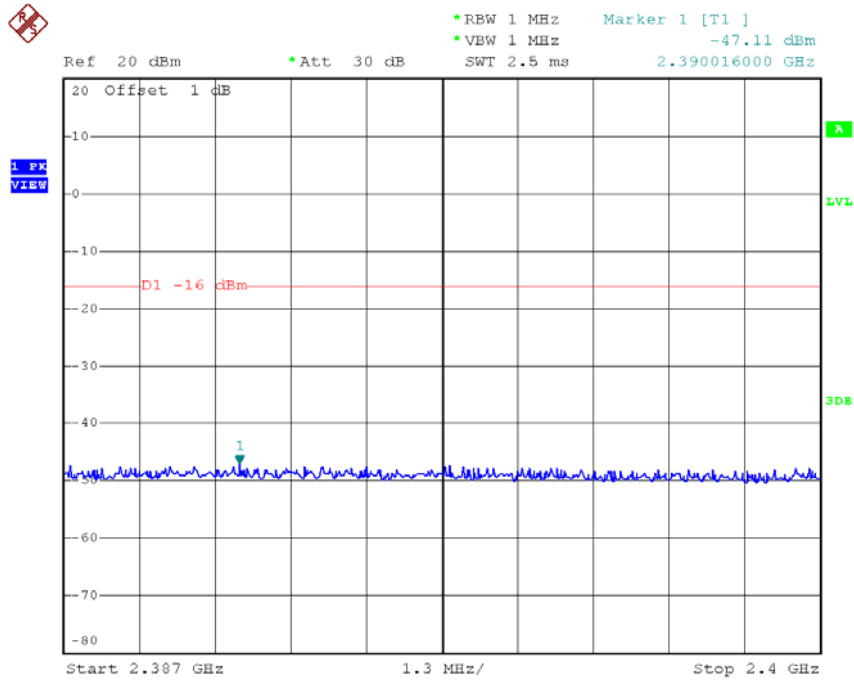

Date: 14.NOV.2015 16:13:19

High Voltage CH13 Frequency Band 4 (2483.5 MHz \cong f < 2496.5 MHz)

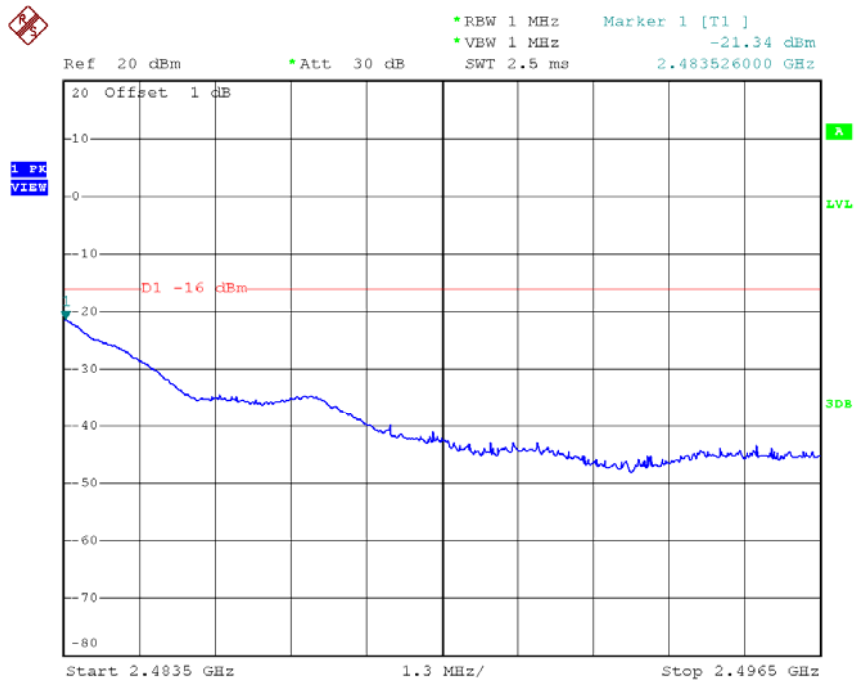

Date: 14.NOV.2015 16:13:28

High Voltage

CH13 Frequency Band 5 (2496.5 MHz \cong f <12.5 GHz)

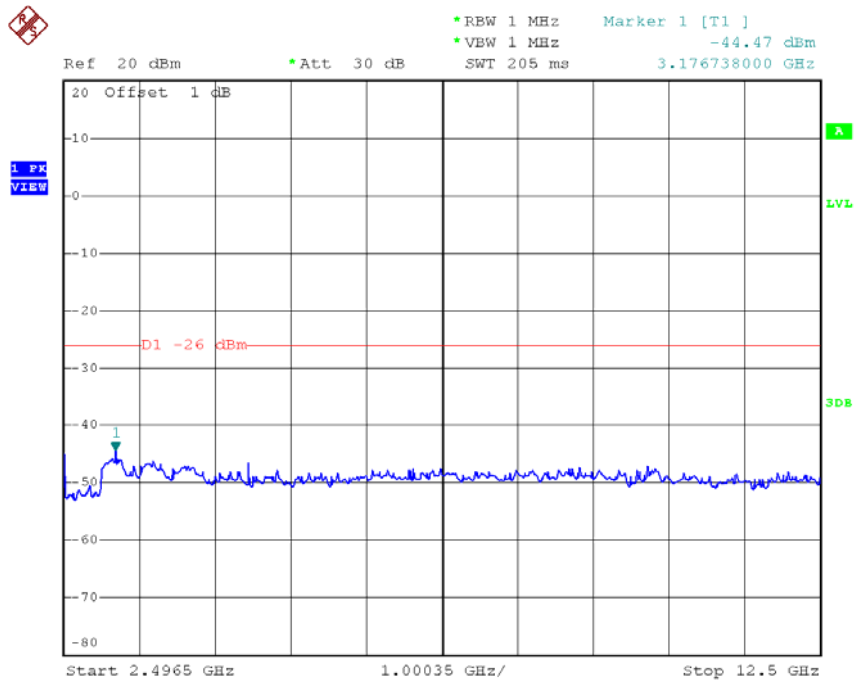

Date: 14.NOV.2015 16:13:39

Low Voltage

CH01 Frequency Band 1 (30 MHz \leq f \leq 1000 MHz)

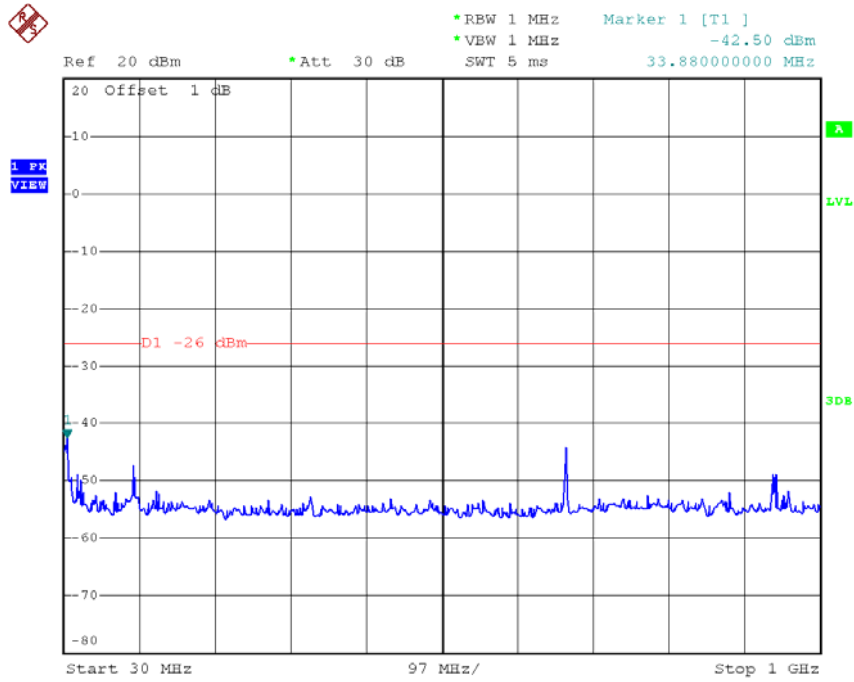

Date: 14.NOV.2015 15:24:48

Low Voltage

CH01 Frequency Band 2 (1000 MHz < f \leq 2387 MHz)

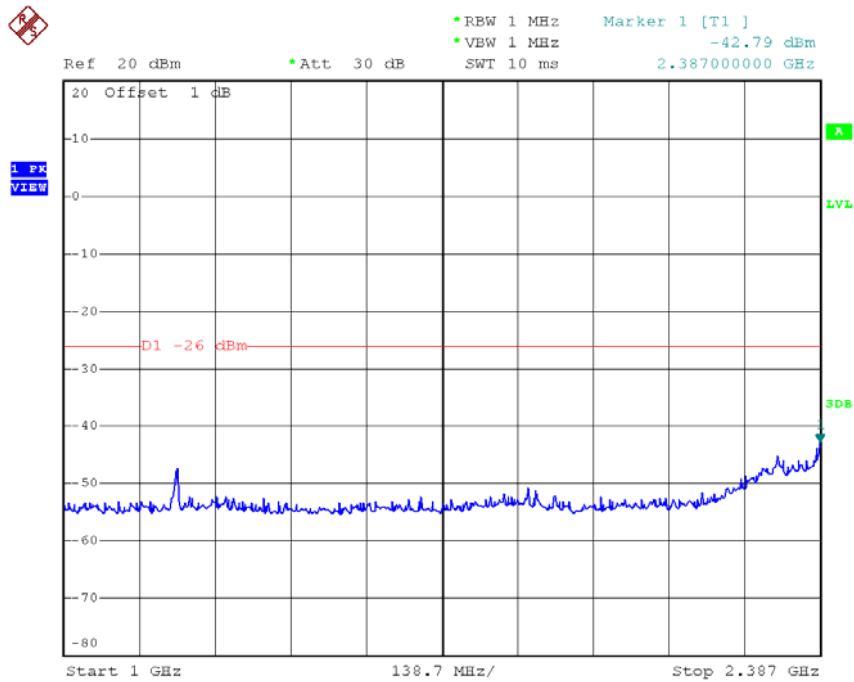

Date: 14.NOV.2015 15:24:58

Low Voltage CH01 Frequency Band 3 (2387 MHz \cong f < 2400 MHz)

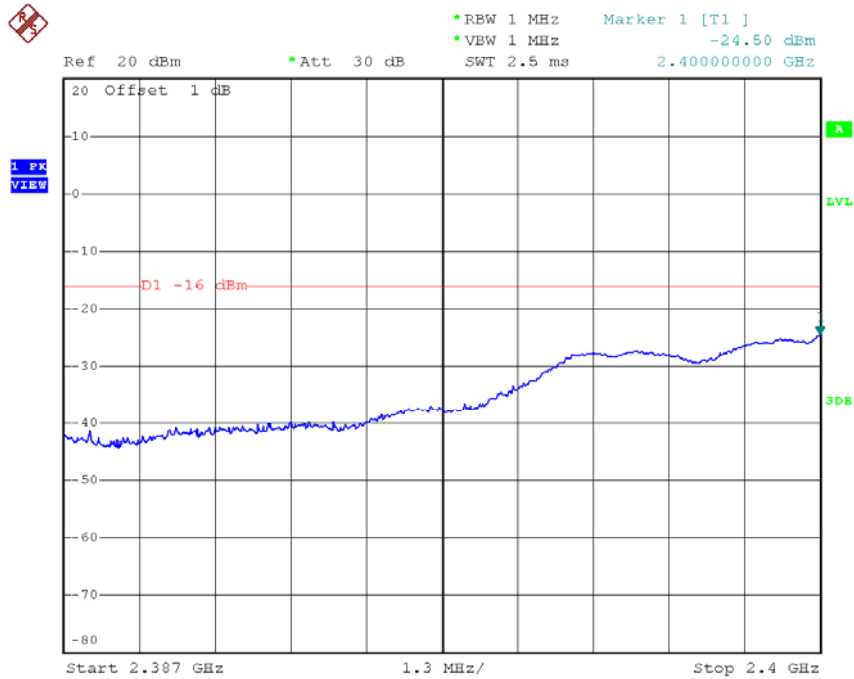

Date: 14.NOV.2015 15:25:09

Low Voltage CH01 Frequency Band 4 (2483.5 MHz \cong f < 2496.5 MHz)

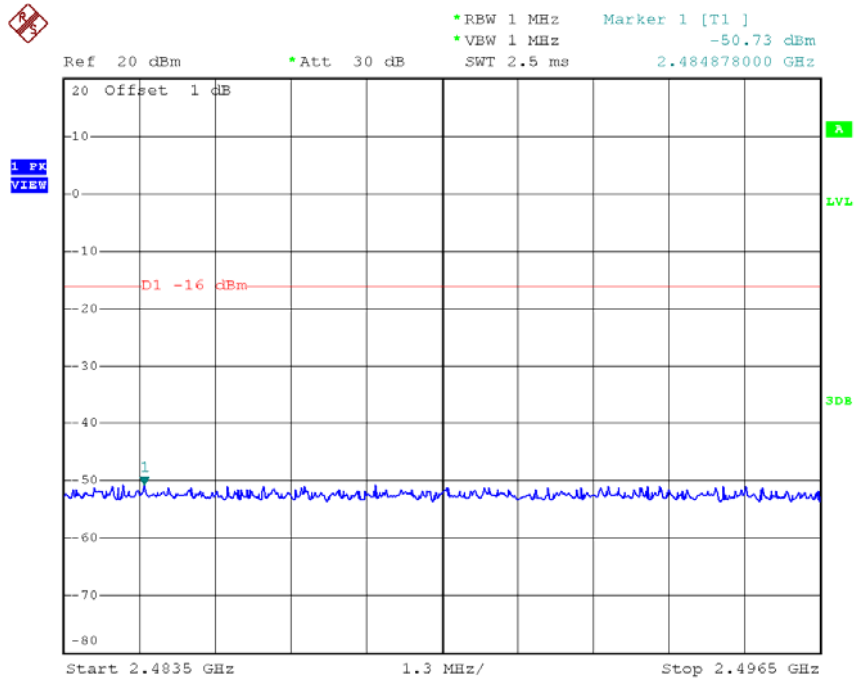

Date: 14.NOV.2015 15:25:19

Low Voltage

CH01 Frequency Band 5 (2496.5 MHz \leq f < 12.5 GHz)

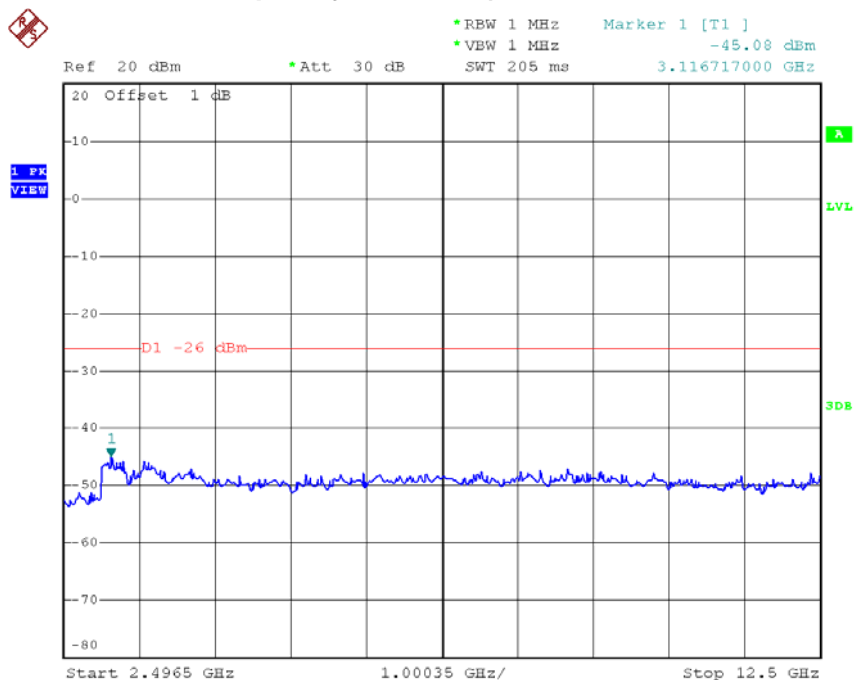

Date: 14.NOV.2015 15:25:30

Low Voltage

CH07 Frequency Band 1 (30 MHz \leq f \leq 1000 MHz)

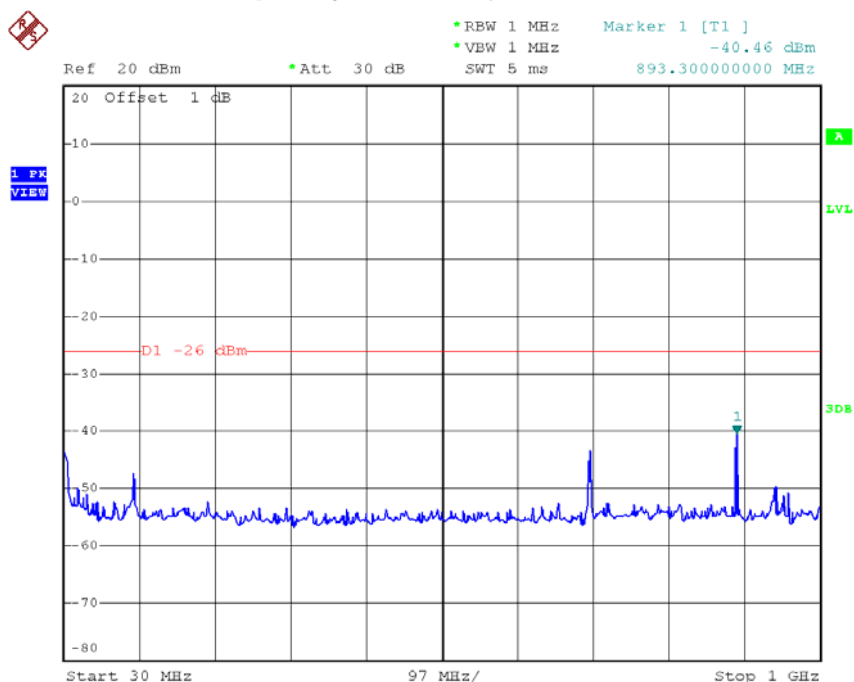

Date: 14.NOV.2015 15:45:05

Low Voltage

CH07 Frequency Band 2 (1000 MHz $f \leq 2387 \text{ MHz}$)

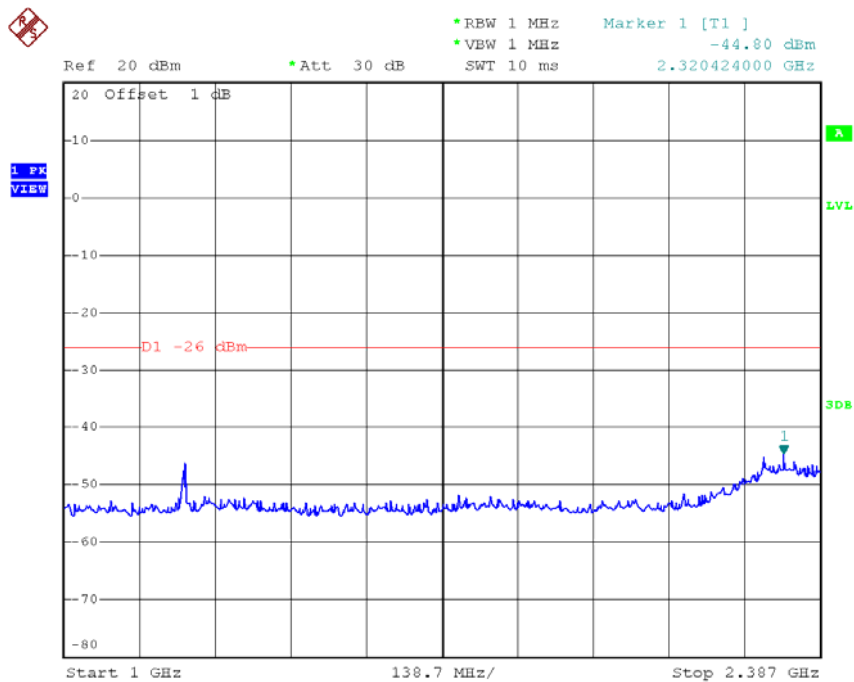

Date: 14.NOV.2015 15:45:16

Low Voltage

CH07 Frequency Band 3 (2387 MHz $\leq f < 2400 \text{ MHz}$)

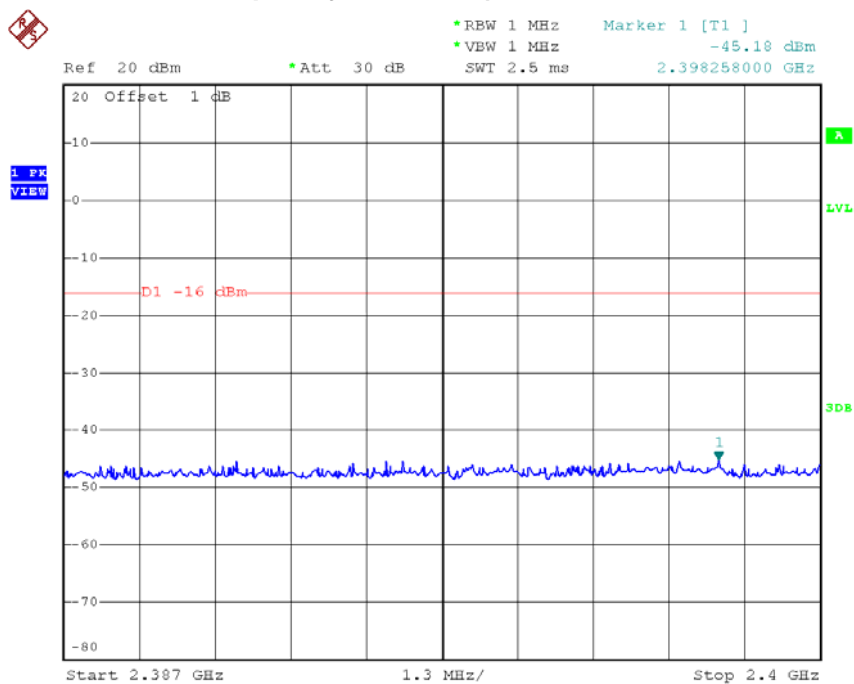

Date: 14.NOV.2015 15:45:27

Low Voltage

CH07 Frequency Band 4 ($2483.5 \text{ MHz} \leq f < 2496.5 \text{ MHz}$)

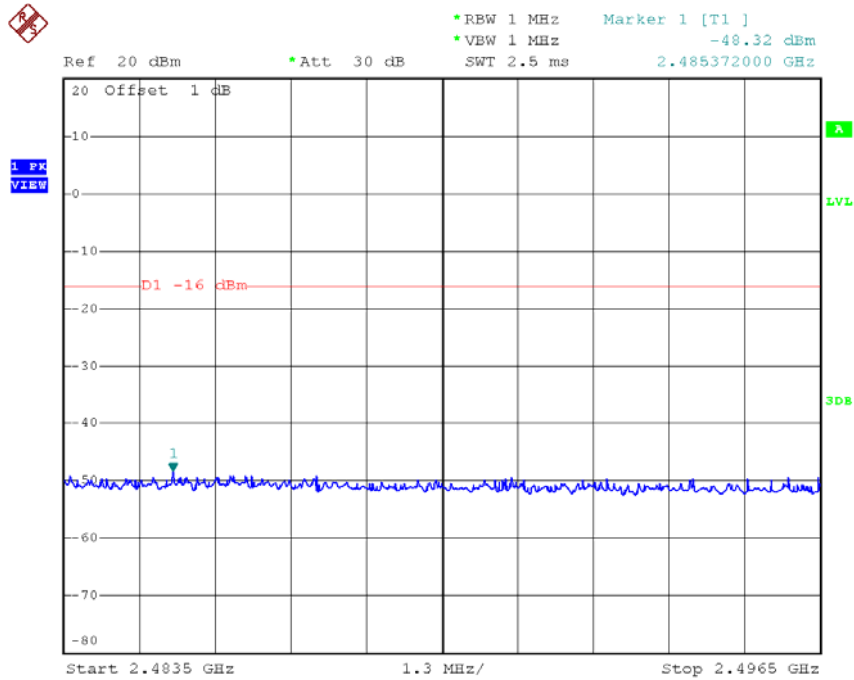

Date: 14.NOV.2015 15:45:37

Low Voltage

CH07 Frequency Band 5 ($2496.5 \text{ MHz} \leq f < 12.5 \text{ GHz}$)

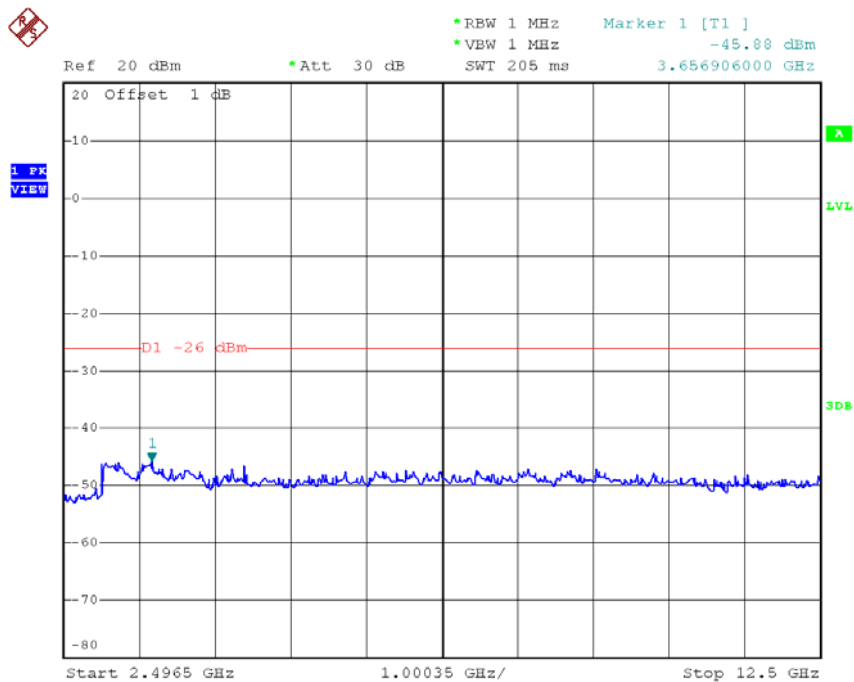

Date: 14.NOV.2015 15:45:47

Low Voltage

CH13 Frequency Band 1 (30 MHz \leq f \leq 1000 MHz)

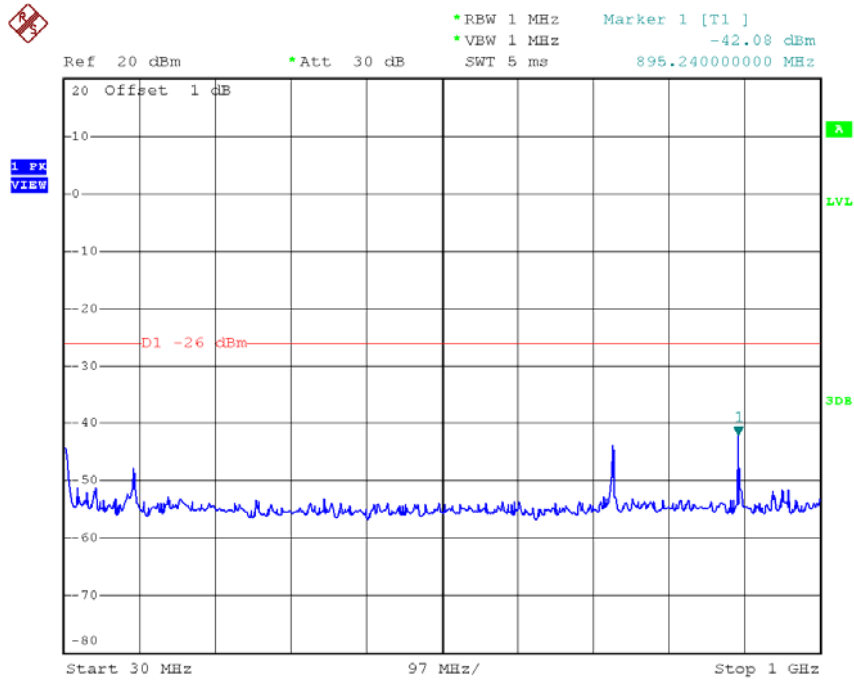

Date: 14.NOV.2015 16:22:47

Low Voltage

CH13 Frequency Band 2 (1000 MHz < f \leq 2387 MHz)

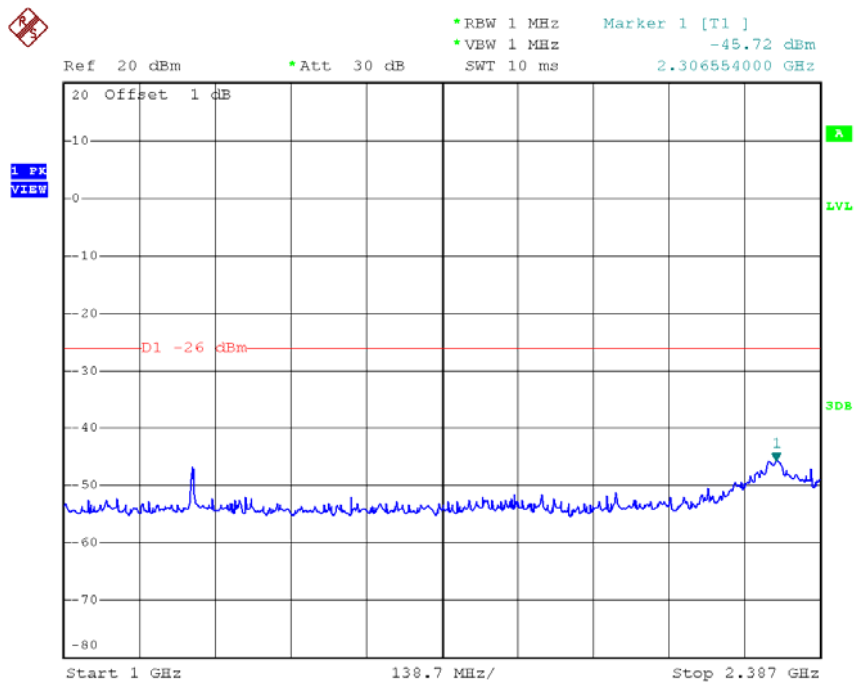

Date: 14.NOV.2015 16:22:58

Low Voltage

CH13 Frequency Band 3 (2387 MHz \leq f < 2400 MHz)

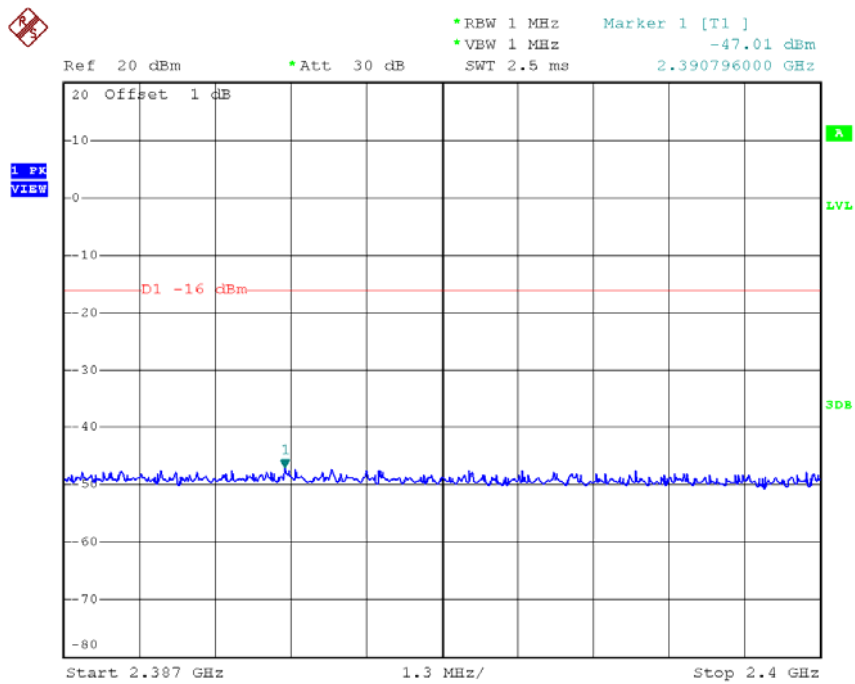

Date: 14.NOV.2015 16:23:09

Low Voltage

CH13 Frequency Band 4 (2483.5 MHz \leq f < 2496.5 MHz)

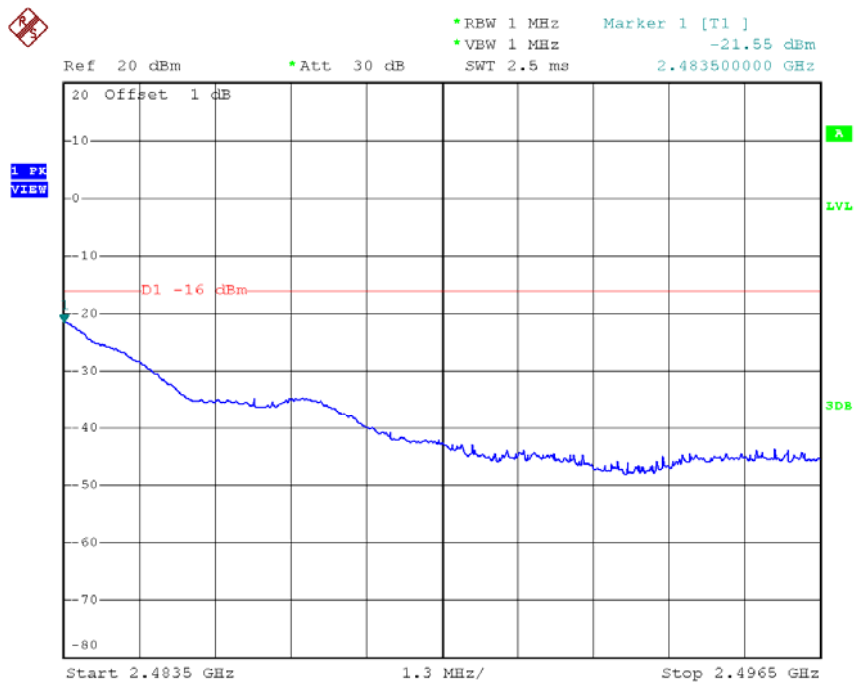

Date: 14.NOV.2015 16:23:19

Low Voltage

CH13 Frequency Band 5 (2496.5 MHz \cong f <12.5 GHz)

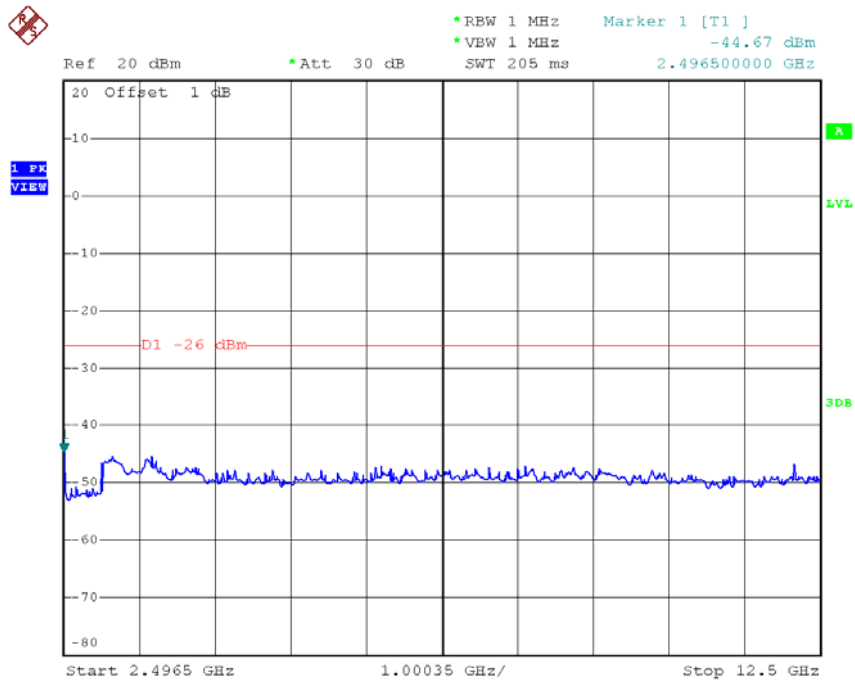

Date: 14.NOV.2015 16:23:30

Test Mode:	802.11g/CH01,CH07,CH13
------------	------------------------

Test Voltage		V	Normal Voltage			Remarks
Test Frequency		MHz	2412	2442	2472	Low/Mid/High of test frequency range
Unwanted Emission Intensity (Power emission within 1MHz bandwidth) (units: μ W)	※ 1	μ W/MHz	0.05808	0.05105	0.00621	Limit \leq 2.5 μ W/MHz (-26 dBm/MHz)
	※ 2	μ W/MHz	0.11940	0.10399	0.01563	Limit \leq 2.5 μ W/MHz (-26 dBm/MHz)
	※ 3	μ W/MHz	4.24620	0.71121	0.01072	Limit \leq 25 μ W/MHz (-16 dBm/MHz)
	※ 4	μ W/MHz	0.01028	0.28054	9.84011	Limit \leq 25 μ W/MHz (-16 dBm/MHz)
	※ 5	μ W/MHz	0.03013	0.03802	0.02891	Limit \leq 2.5 μ W/MHz (-26 dBm/MHz)

Test Voltage		V	High Voltage			Remarks
Test Frequency		MHz	2412	2442	2472	Low/Mid/High of test frequency range
Unwanted Emission Intensity (Power emission within 1MHz bandwidth) (units: μ W)	※ 1	μ W/MHz	0.06368	0.04645	0.00605	Limit \leq 2.5 μ W/MHz (-26 dBm/MHz)
	※ 2	μ W/MHz	0.11912	0.11830	0.01521	Limit \leq 2.5 μ W/MHz (-26 dBm/MHz)
	※ 3	μ W/MHz	4.40555	0.66988	0.01045	Limit \leq 25 μ W/MHz (-16 dBm/MHz)
	※ 4	μ W/MHz	0.01125	0.24946	12.73503	Limit \leq 25 μ W/MHz (-16 dBm/MHz)
	※ 5	μ W/MHz	0.03334	0.03565	0.03192	Limit \leq 2.5 μ W/MHz (-26 dBm/MHz)

Test Voltage		V	Low Voltage			Remarks
Test Frequency		MHz	2412	2442	2472	Low/Mid/High of test frequency range
Unwanted Emission Intensity (Power emission within 1MHz bandwidth) (units: μ W)	※ 1	μ W/MHz	0.06223	0.04457	0.00535	Limit \leq 2.5 μ W/MHz (-26 dBm/MHz)
	※ 2	μ W/MHz	0.10990	0.11066	0.01374	Limit \leq 2.5 μ W/MHz (-26 dBm/MHz)
	※ 3	μ W/MHz	3.89942	0.74817	0.00968	Limit \leq 25 μ W/MHz (-16 dBm/MHz)
	※ 4	μ W/MHz	0.01023	0.23823	13.48963	Limit \leq 25 μ W/MHz (-16 dBm/MHz)
	※ 5	μ W/MHz	0.03090	0.03228	0.03289	Limit \leq 2.5 μ W/MHz (-26 dBm/MHz)

Normal Voltage
CH01 Frequency Band 1 (30 MHz \leq f \leq 1000 MHz)

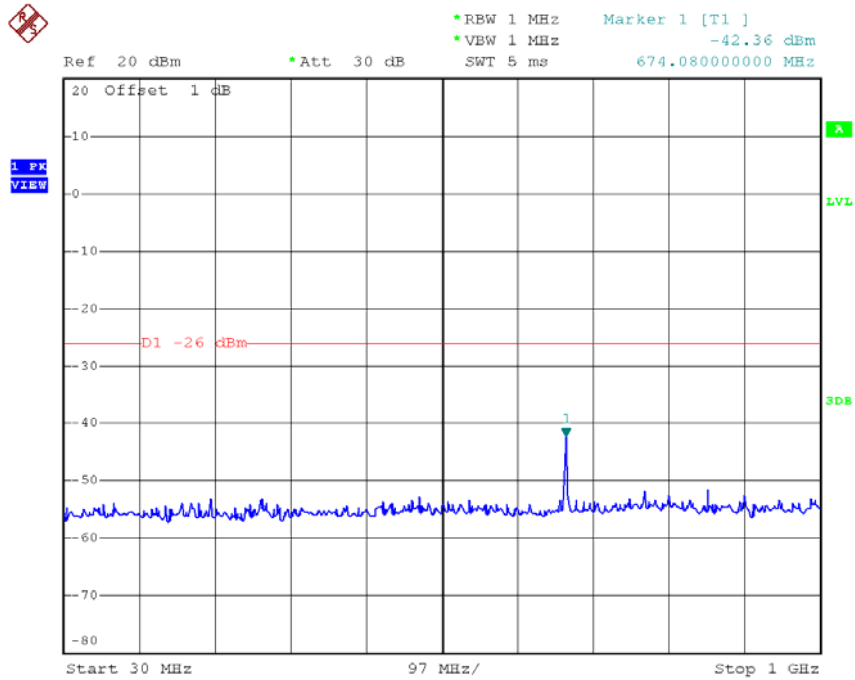

Date: 17.NOV.2015 15:58:11

Normal Voltage
CH01 Frequency Band 2 (1000 MHz < f \leq 2387 MHz)

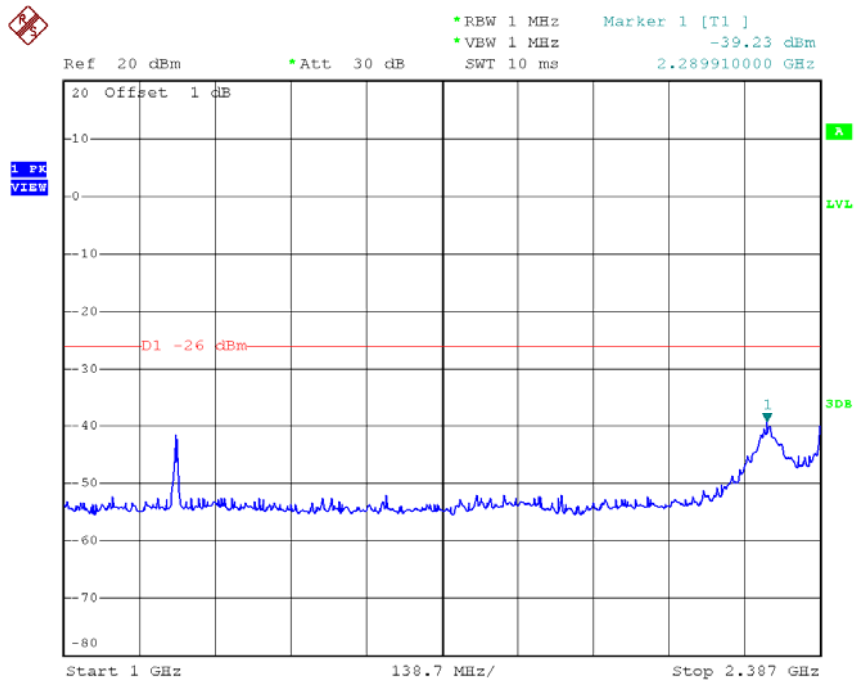

Date: 17.NOV.2015 15:58:21

Normal Voltage CH01 Frequency Band 3 (2387 MHz \cong f < 2400 MHz)

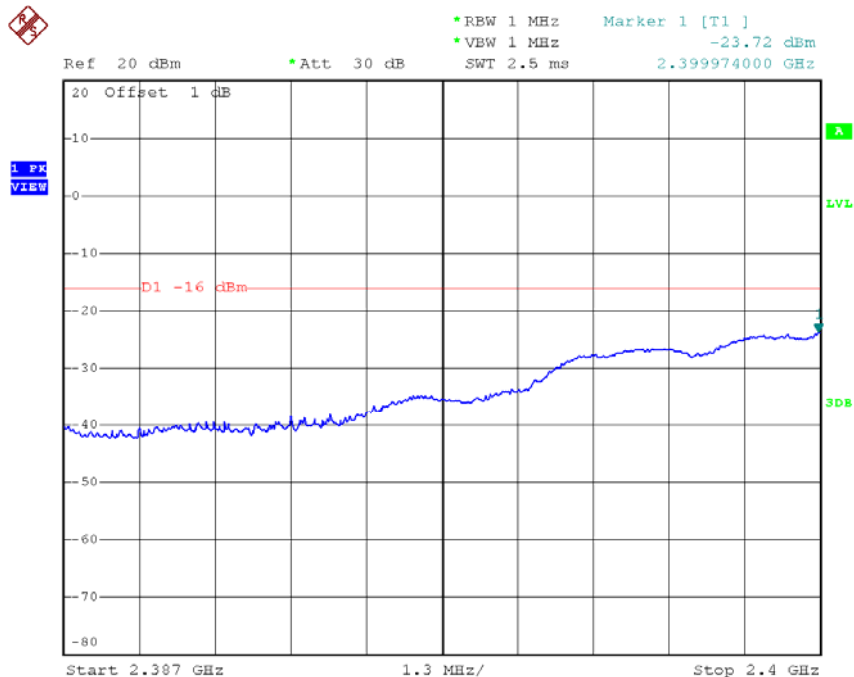

Date: 17.NOV.2015 15:58:31

Normal Voltage CH01 Frequency Band 4 (2483.5 MHz \cong f < 2496.5 MHz)

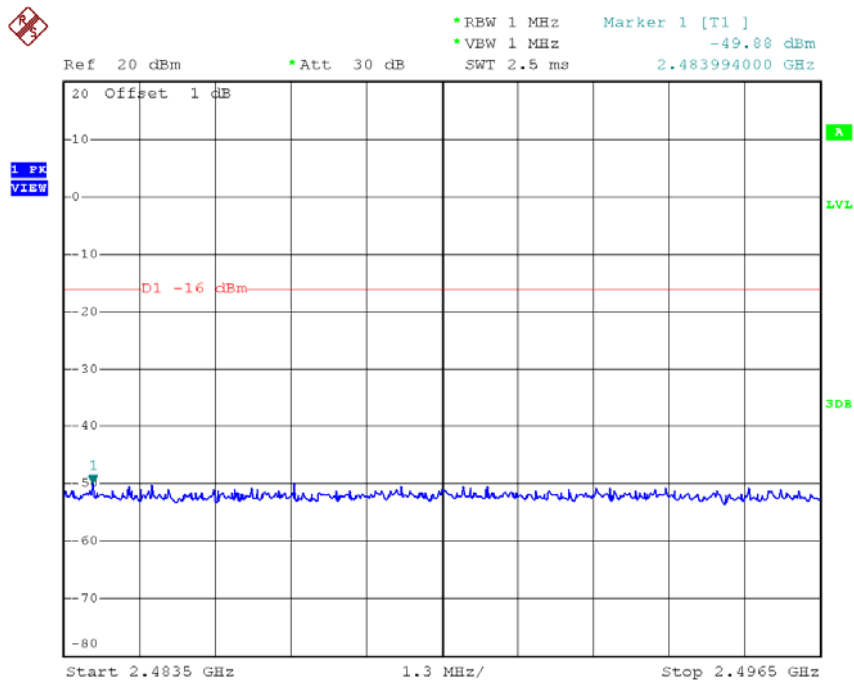

Date: 17.NOV.2015 15:58:40

Normal Voltage
CH01 Frequency Band 5 (2496.5 MHz \leq f < 12.5 GHz)

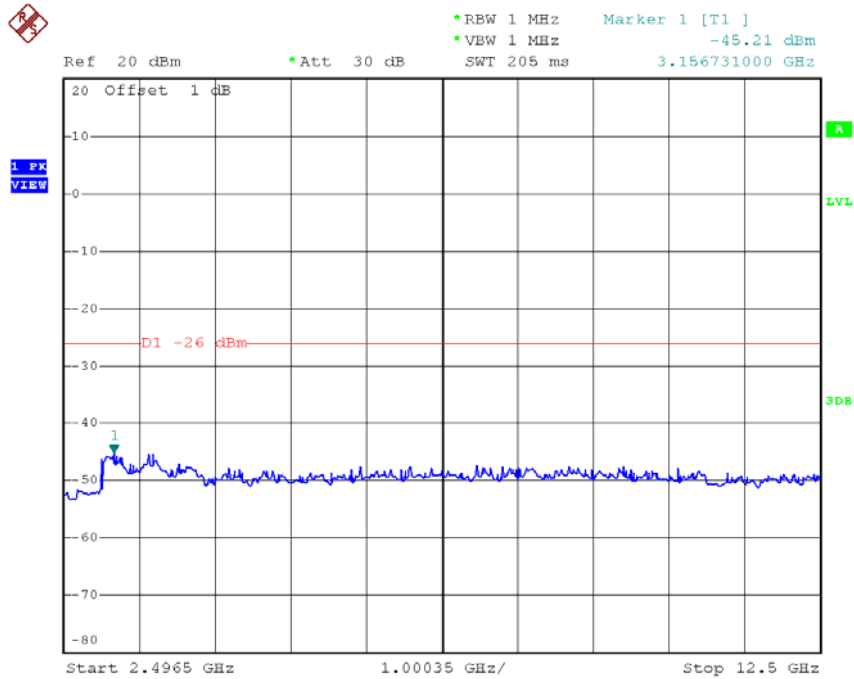

Date: 17.NOV.2015 15:58:51

Normal Voltage
CH07 Frequency Band 1 (30 MHz \leq f \leq 1000 MHz)

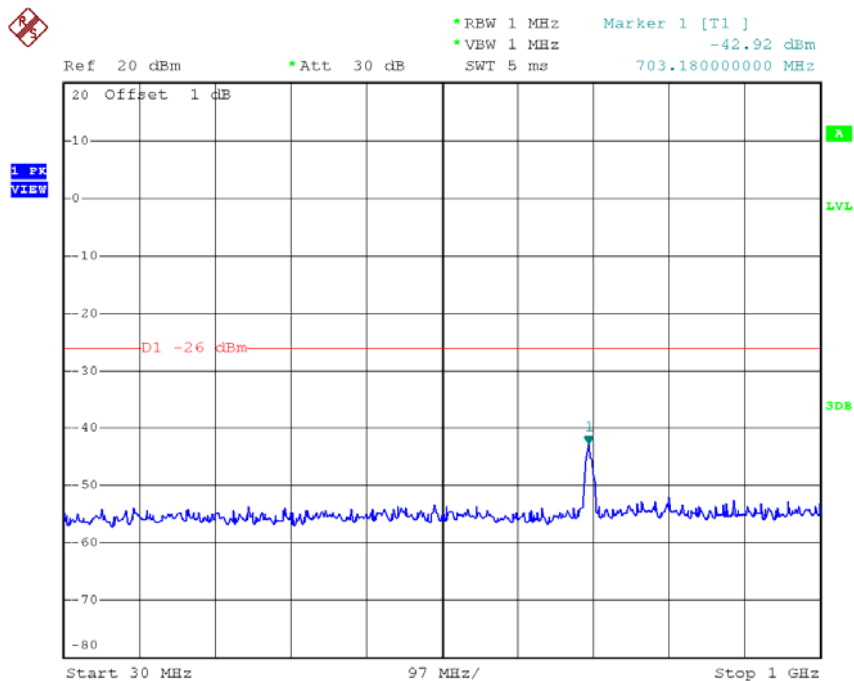

Date: 17.NOV.2015 16:10:56

Normal Voltage
CH07 Frequency Band 2 (1000 MHz < f ≤ 2387 MHz)

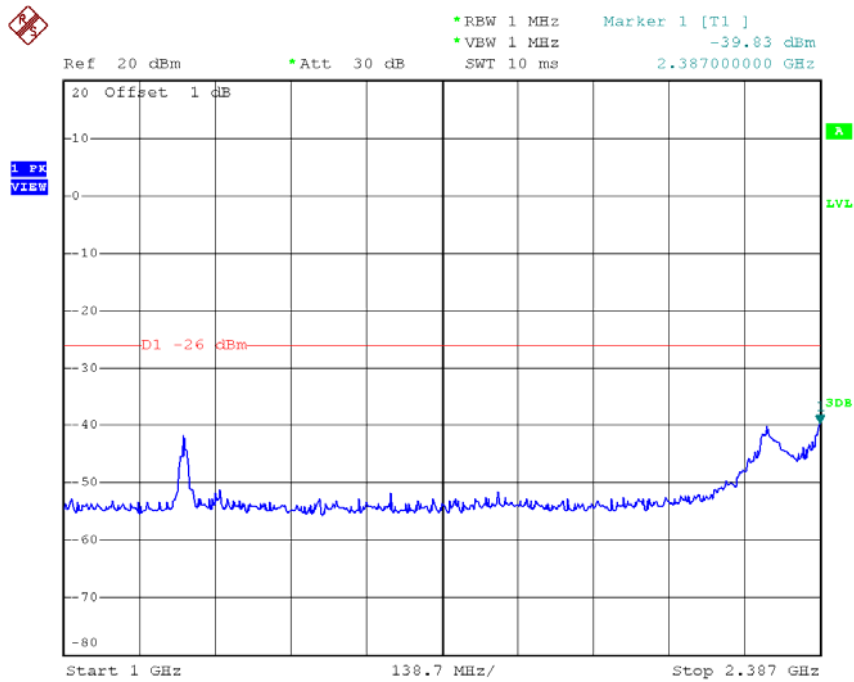

Date: 17.NOV.2015 16:11:06

Normal Voltage
CH07 Frequency Band 3 (2387 MHz ≤ f < 2400 MHz)

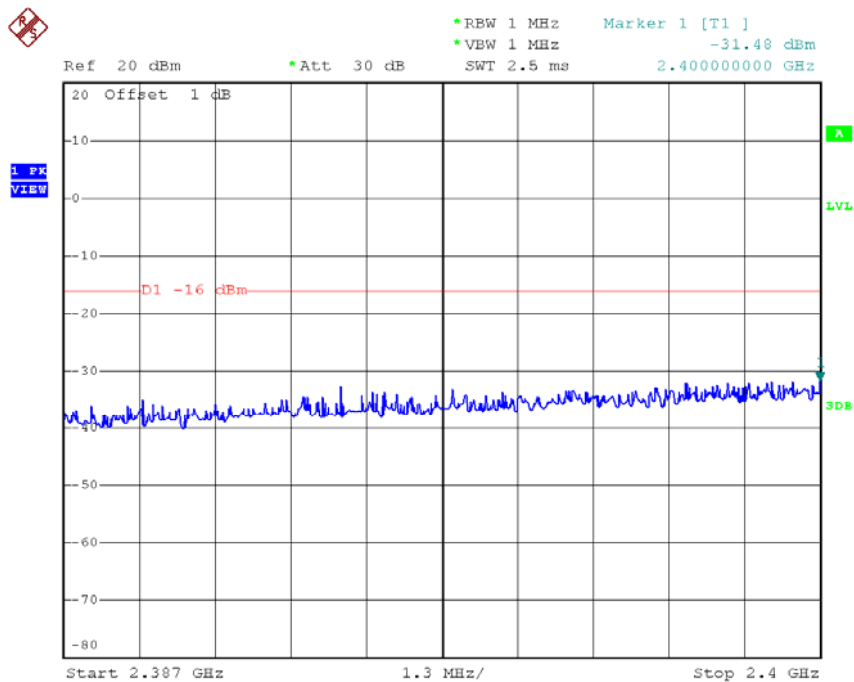

Date: 17.NOV.2015 16:11:16

Normal Voltage

CH07 Frequency Band 4 ($2483.5 \text{ MHz} \leq f < 2496.5 \text{ MHz}$)

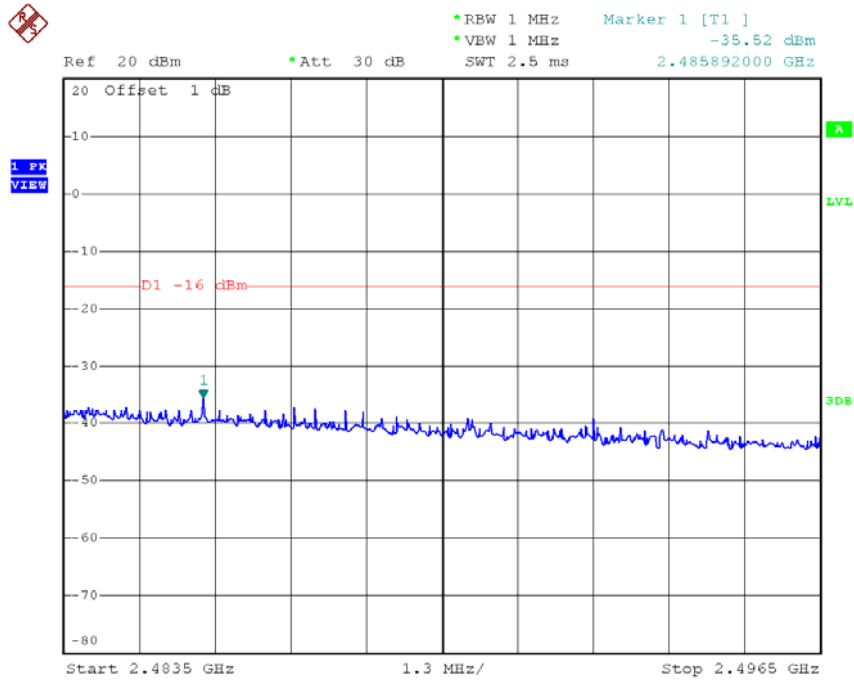

Date: 17.NOV.2015 16:11:25

Normal Voltage

CH07 Frequency Band 5 ($2496.5 \text{ MHz} \leq f < 12.5 \text{ GHz}$)

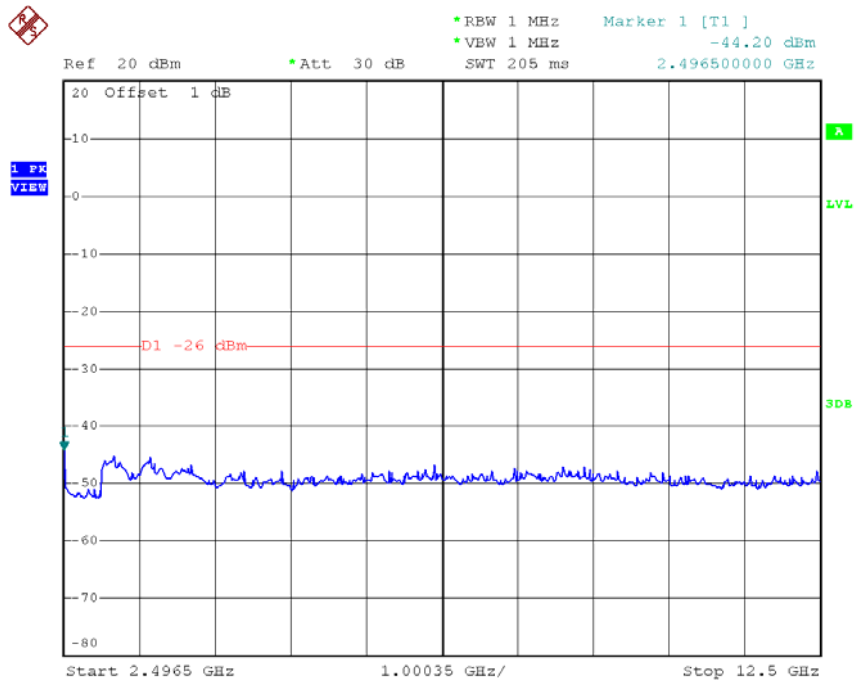

Date: 17.NOV.2015 16:11:35

Normal Voltage
CH13 Frequency Band 3 (2387 MHz \leq f < 2400 MHz)

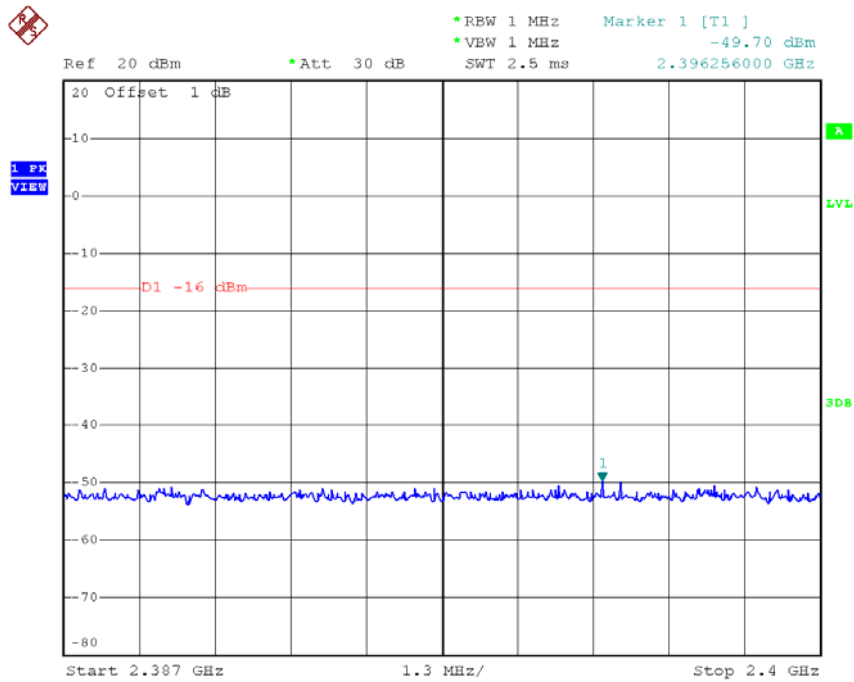

Date: 17.NOV.2015 16:24:23

Normal Voltage
CH13 Frequency Band 4 (2483.5 MHz \leq f < 2496.5 MHz)

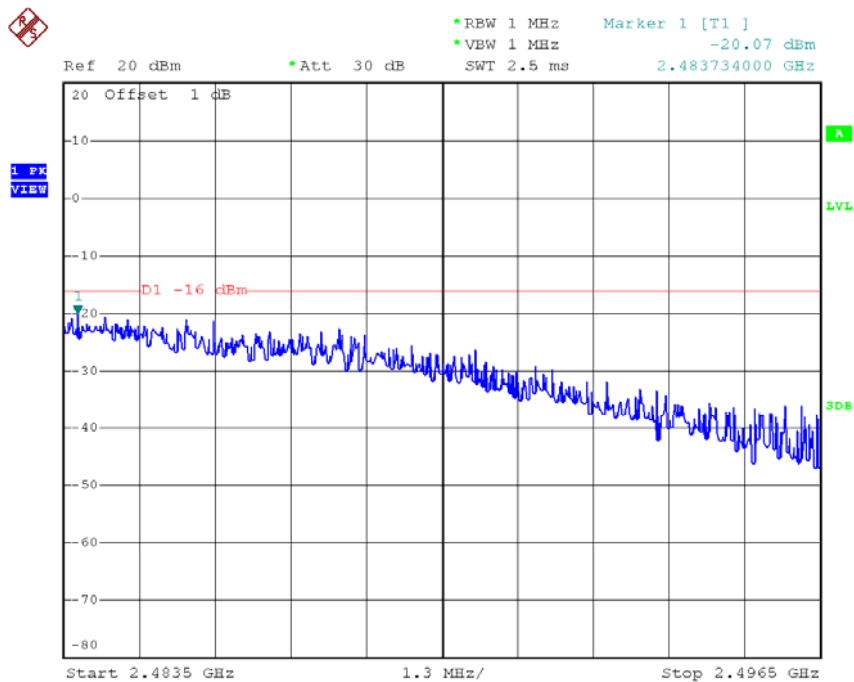

Date: 17.NOV.2015 16:24:32

Normal Voltage
CH13 Frequency Band 5 (2496.5 MHz ≡ f <12.5 GHz)

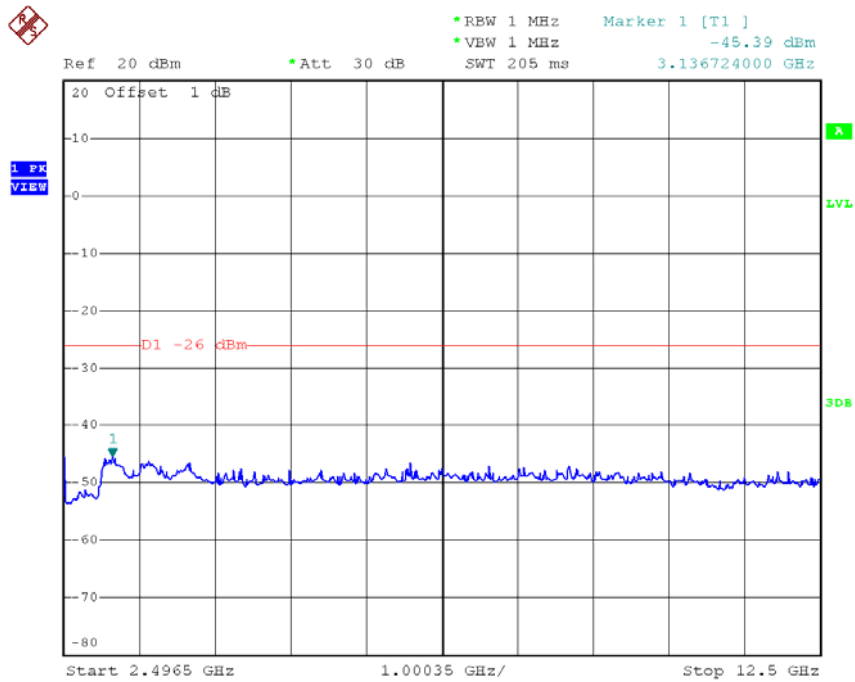

Date: 17.NOV.2015 16:24:42

High Voltage

CH01 Frequency Band 1 ($30 \text{ MHz} \leq f \leq 1000 \text{ MHz}$)

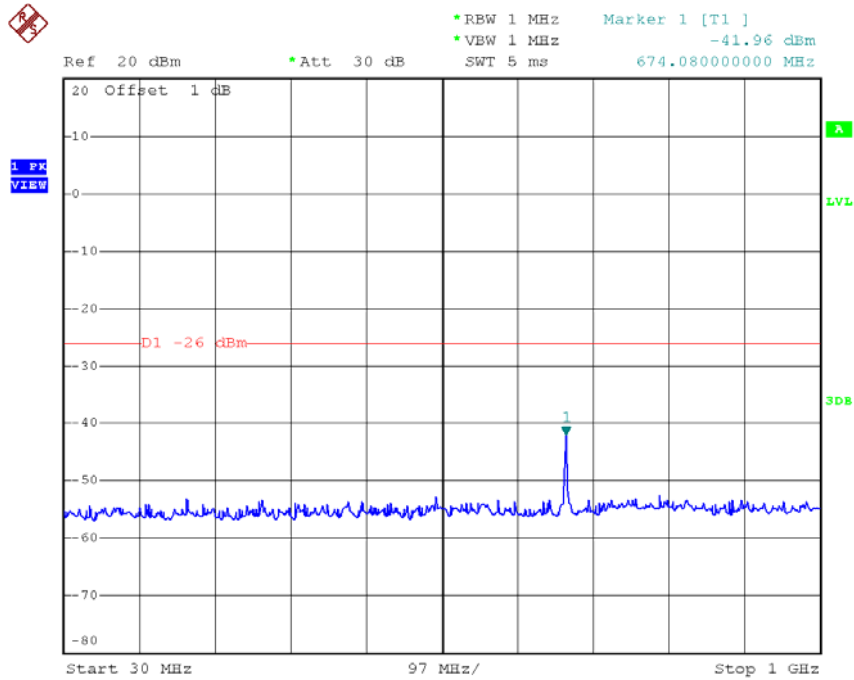

Date: 17.NOV.2015 15:53:17

High Voltage

CH01 Frequency Band 2 ($1000 \text{ MHz} < f \leq 2387 \text{ MHz}$)

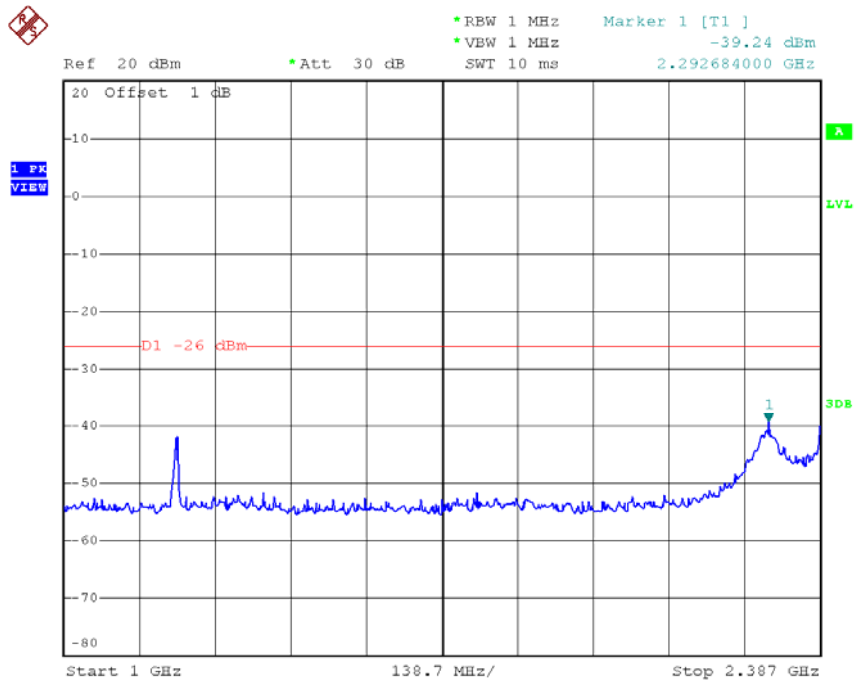

Date: 17.NOV.2015 15:53:27

High Voltage CH01 Frequency Band 3 (2387 MHz \cong f < 2400 MHz)

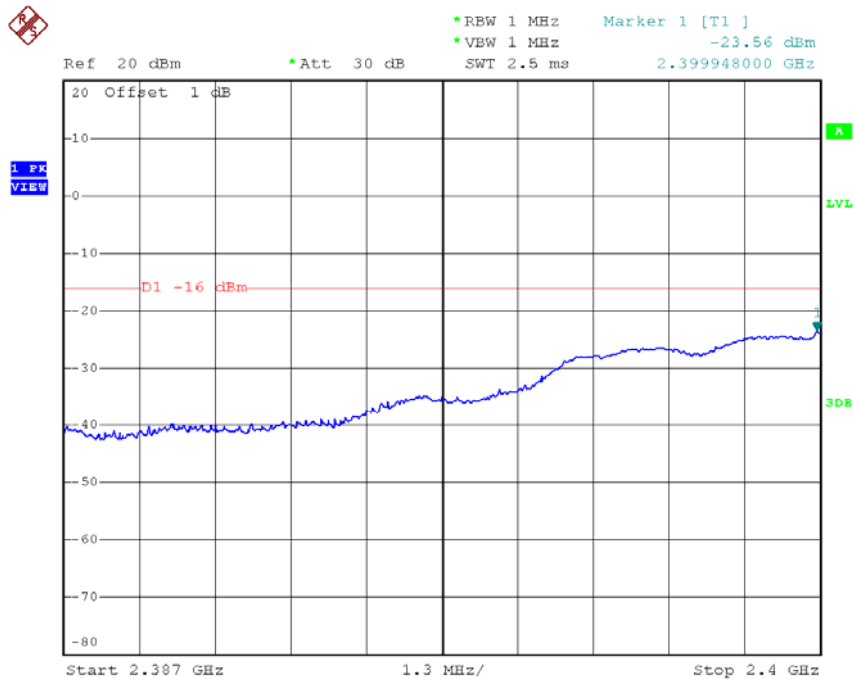

Date: 17.NOV.2015 15:53:37

High Voltage CH01 Frequency Band 4 (2483.5 MHz \cong f < 2496.5 MHz)

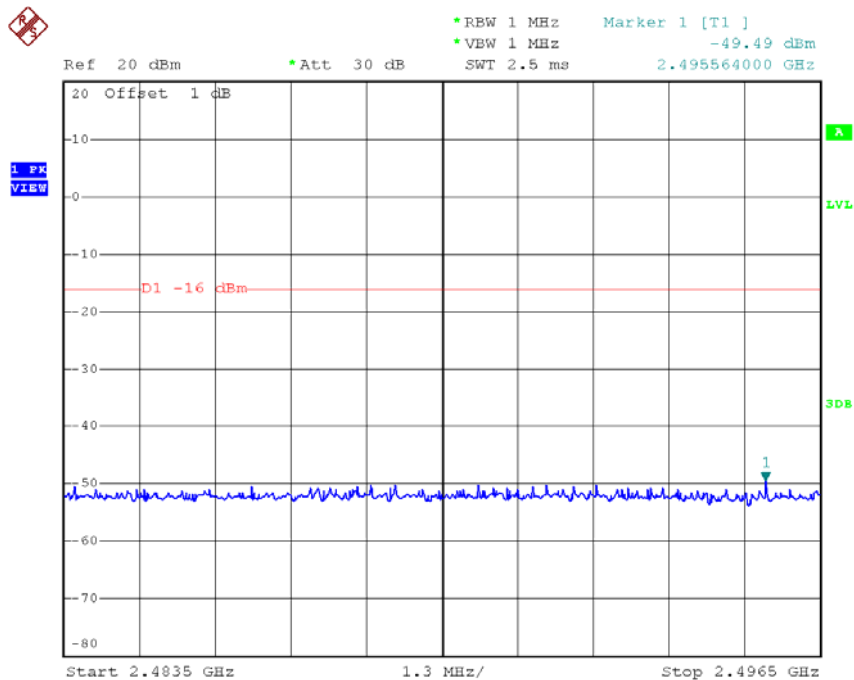

Date: 17.NOV.2015 15:53:46

High Voltage CH01 Frequency Band 5 (2496.5 MHz \leq f < 12.5 GHz)

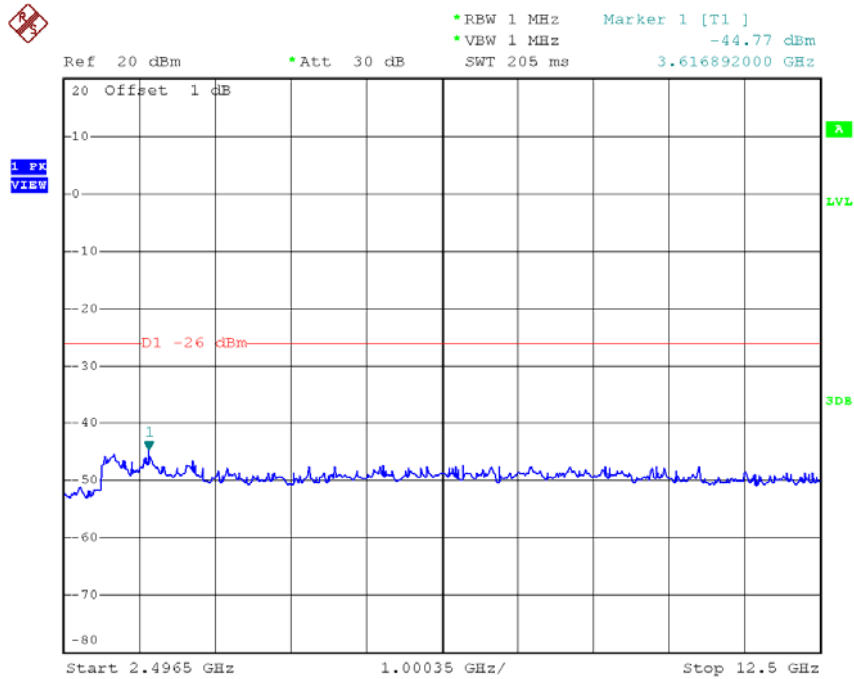

Date: 17.NOV.2015 15:53:56

High Voltage CH07 Frequency Band 1 (30 MHz \leq f \leq 1000 MHz)

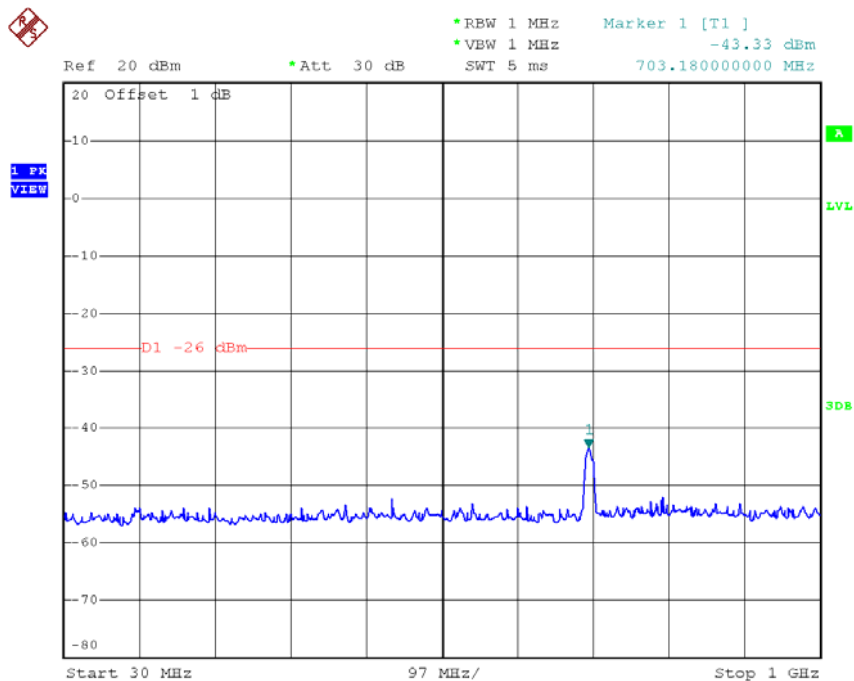

Date: 17.NOV.2015 16:08:11

High Voltage

CH07 Frequency Band 2 (1000 MHz $f \leq 2387 \text{ MHz}$)

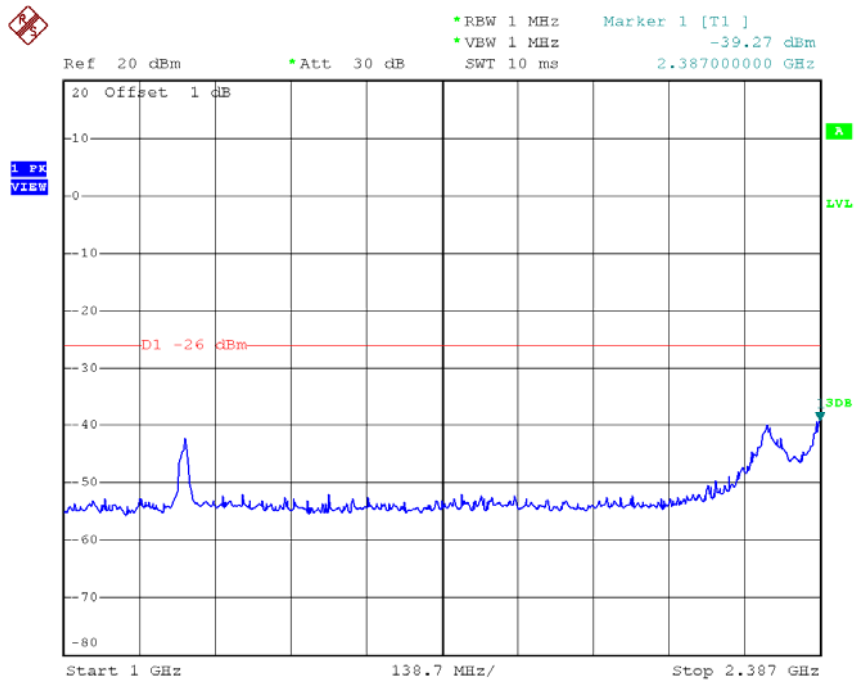

Date: 17.NOV.2015 16:08:21

High Voltage

CH07 Frequency Band 3 (2387 MHz $\leq f < 2400 \text{ MHz}$)

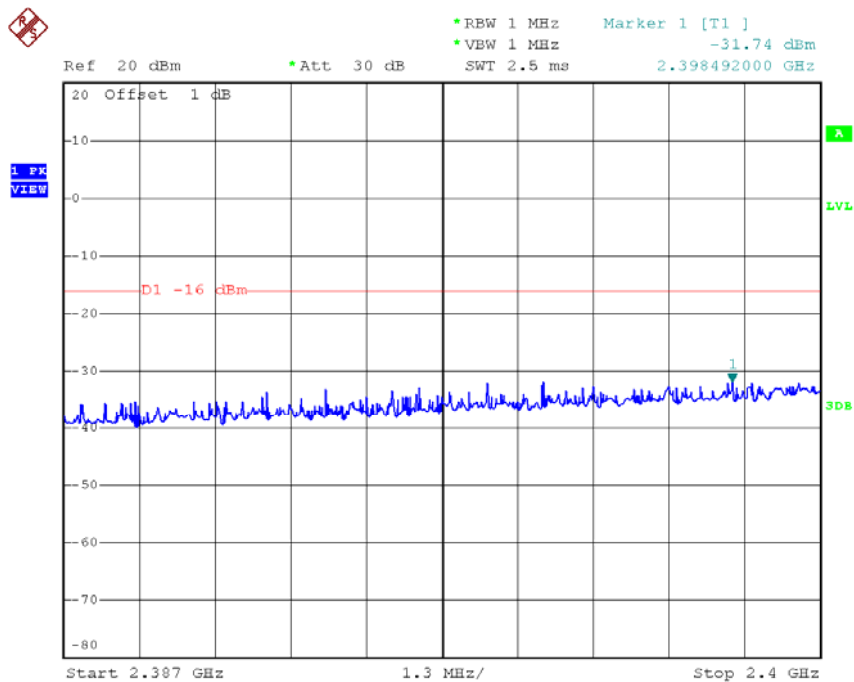

Date: 17.NOV.2015 16:08:31

High Voltage

CH07 Frequency Band 4 ($2483.5 \text{ MHz} \leq f < 2496.5 \text{ MHz}$)

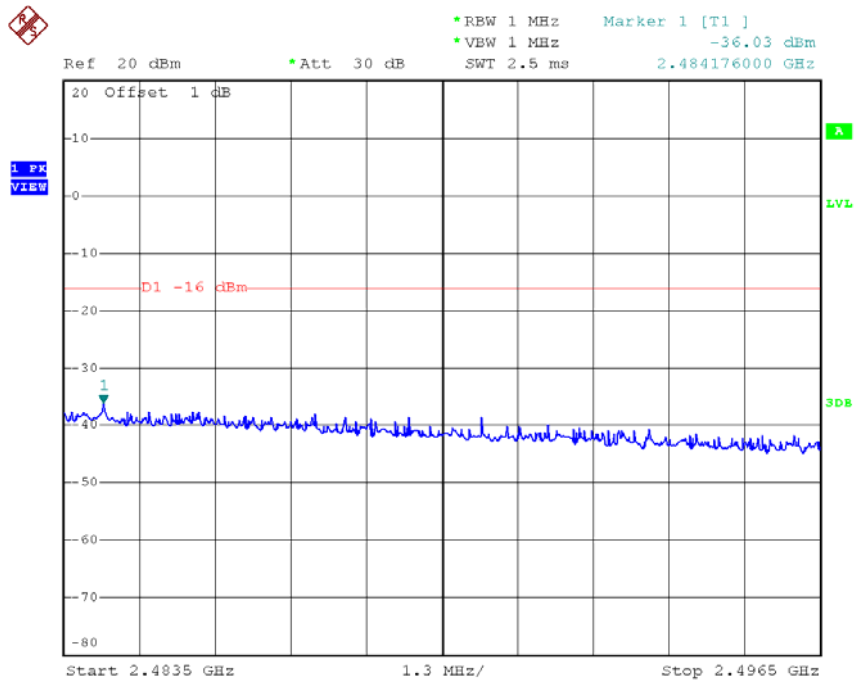

Date: 17.NOV.2015 16:08:41

High Voltage

CH07 Frequency Band 5 ($2496.5 \text{ MHz} \leq f < 12.5 \text{ GHz}$)

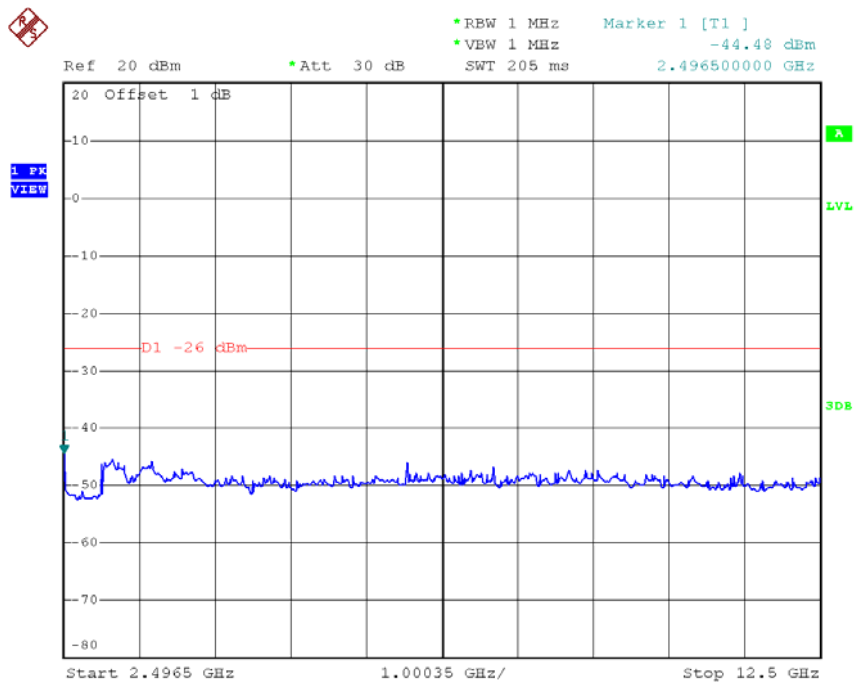

Date: 17.NOV.2015 16:08:51

High Voltage

CH13 Frequency Band 1 (30 MHz \leq f \leq 1000 MHz)

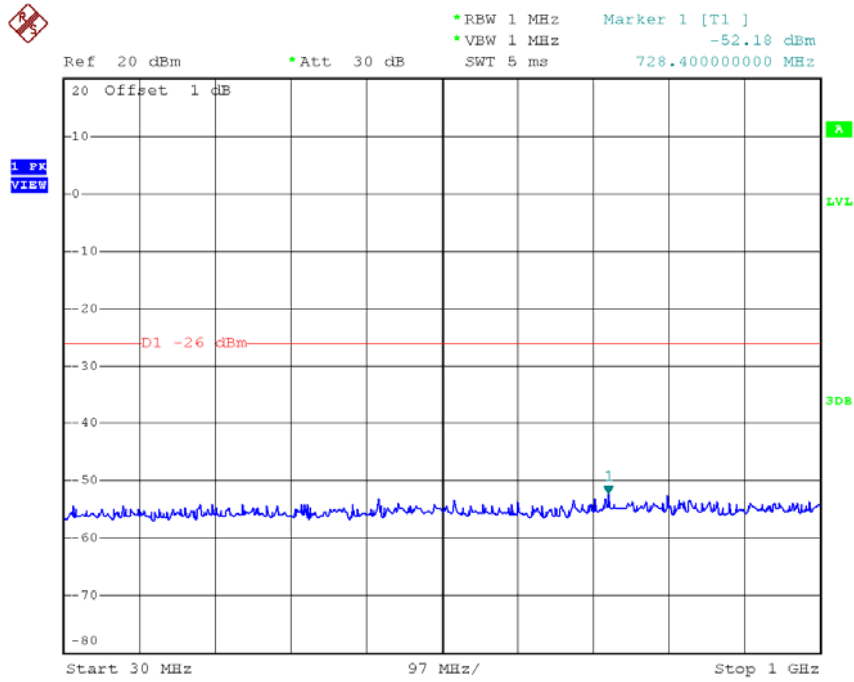

Date: 17.NOV.2015 16:21:26

High Voltage

CH13 Frequency Band 2 (1000 MHz < f \leq 2387 MHz)

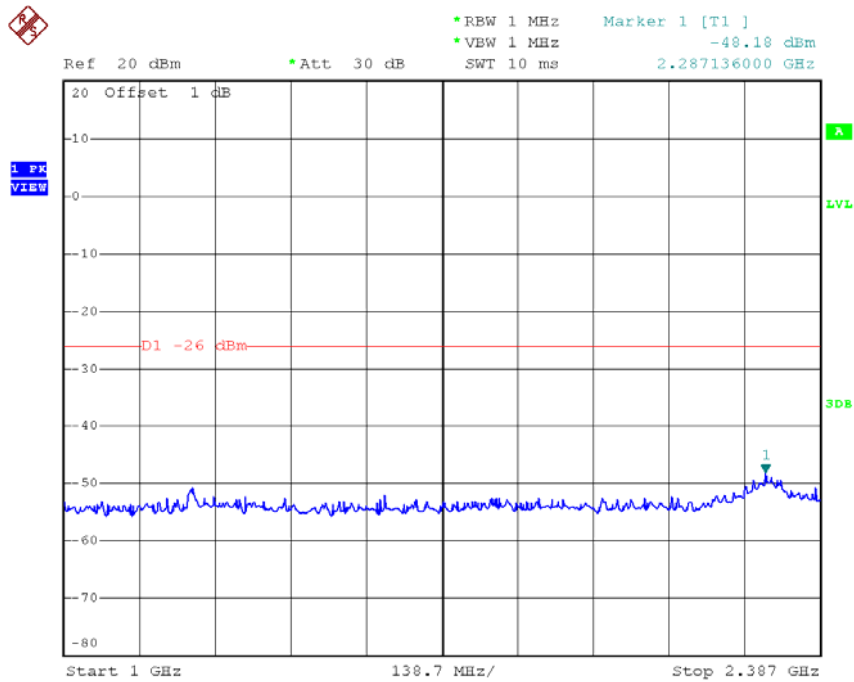

Date: 17.NOV.2015 16:21:37

High Voltage

CH13 Frequency Band 5 (2496.5 MHz \cong f <12.5 GHz)

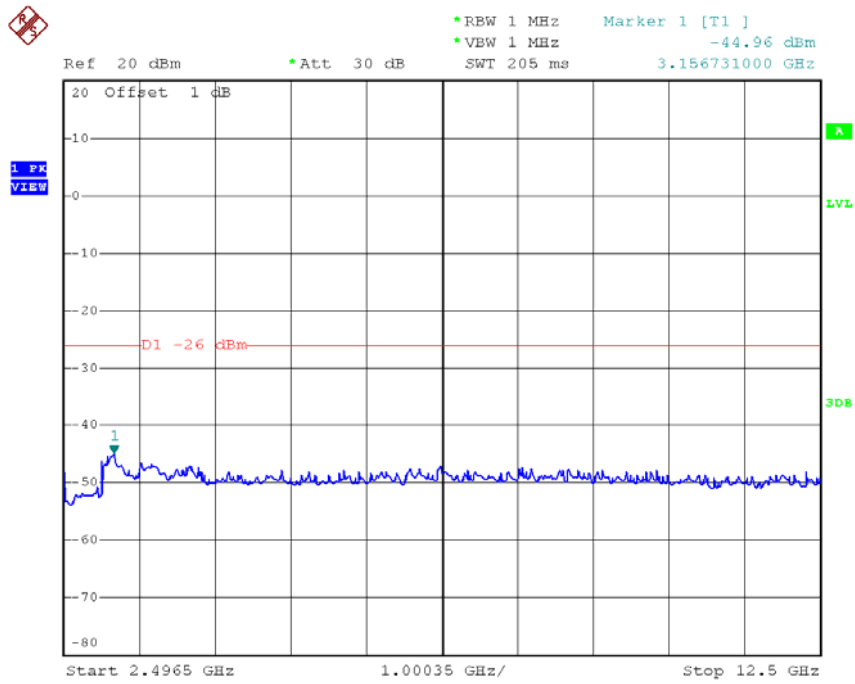

Date: 17.NOV.2015 16:22:06

Low Voltage

CH01 Frequency Band 1 (30 MHz \leq f \leq 1000 MHz)

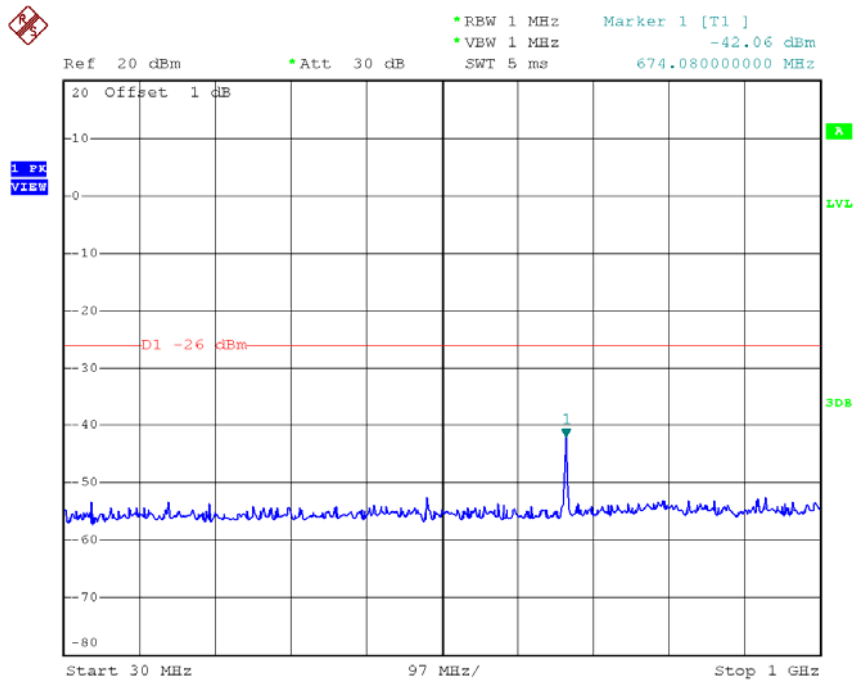

Date: 17.NOV.2015 16:01:38

Low Voltage

CH01 Frequency Band 2 (1000 MHz < f \leq 2387 MHz)

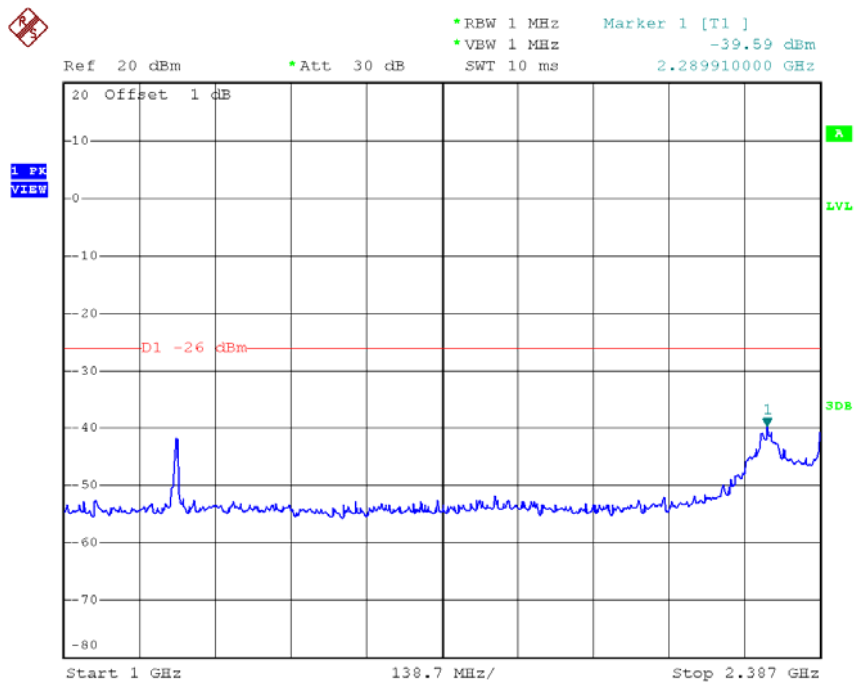

Date: 17.NOV.2015 16:01:48

Low Voltage CH01 Frequency Band 3 (2387 MHz \cong f < 2400 MHz)

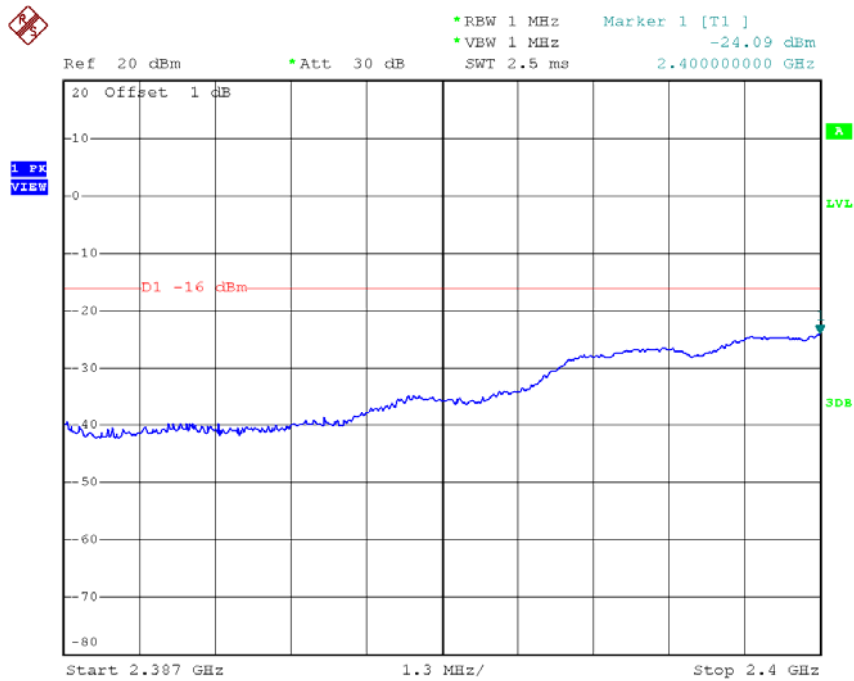

Date: 17.NOV.2015 16:01:58

Low Voltage CH01 Frequency Band 4 (2483.5 MHz \cong f < 2496.5 MHz)

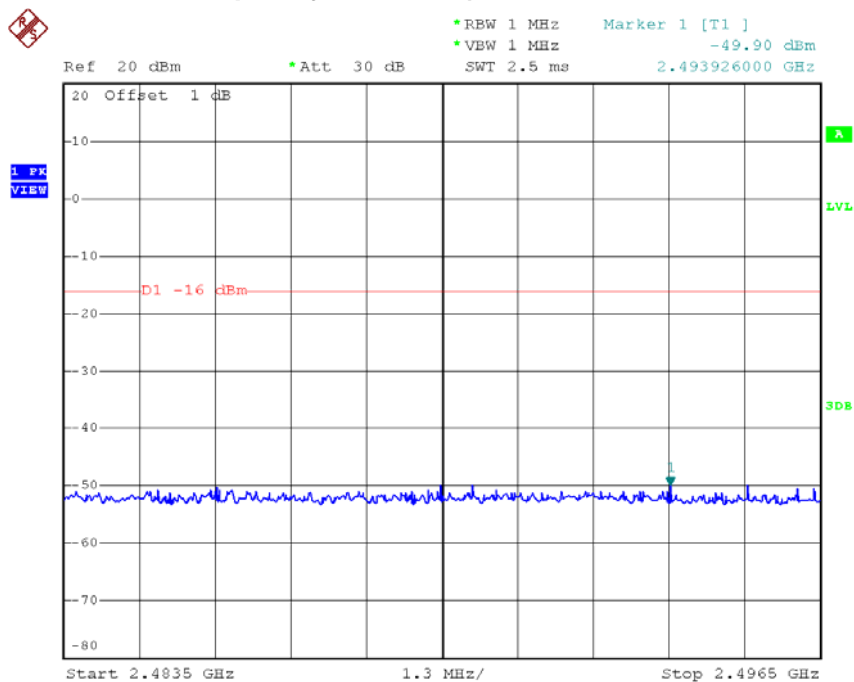

Date: 17.NOV.2015 16:02:08

Low Voltage

CH01 Frequency Band 5 (2496.5 MHz \leq f < 12.5 GHz)

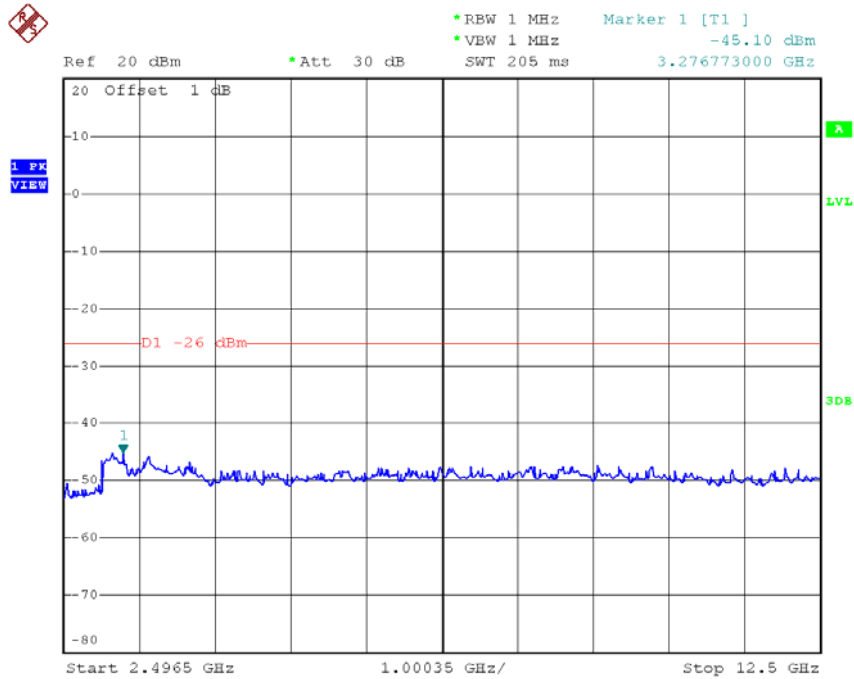

Date: 17.NOV.2015 16:02:18

Low Voltage

CH07 Frequency Band 1 (30 MHz \leq f \leq 1000 MHz)

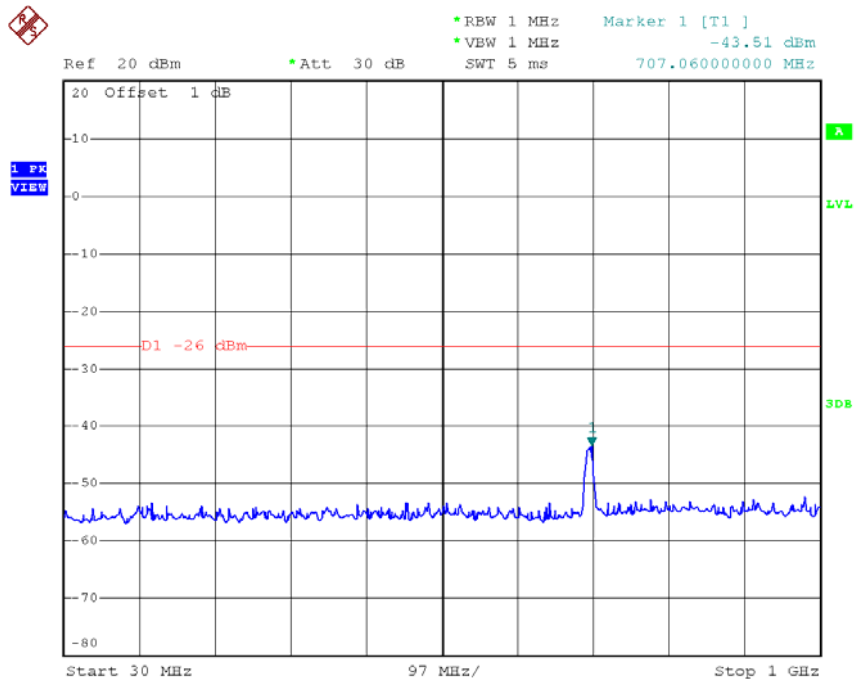

Date: 17.NOV.2015 16:13:52

Low Voltage

CH07 Frequency Band 2 (1000 MHz < f ≤ 2387 MHz)

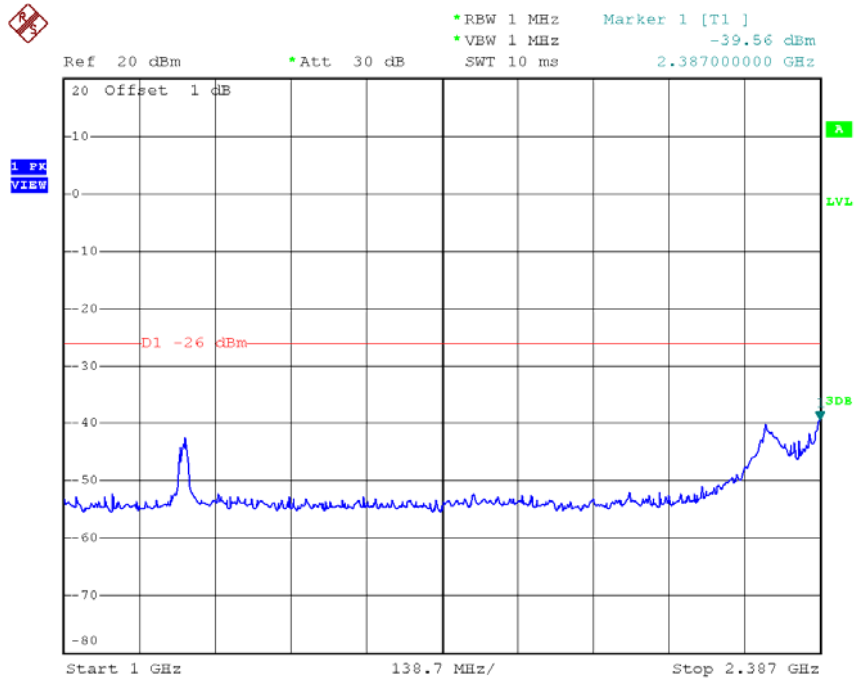

Date: 17.NOV.2015 16:14:02

Low Voltage

CH07 Frequency Band 3 (2387 MHz ≤ f < 2400 MHz)

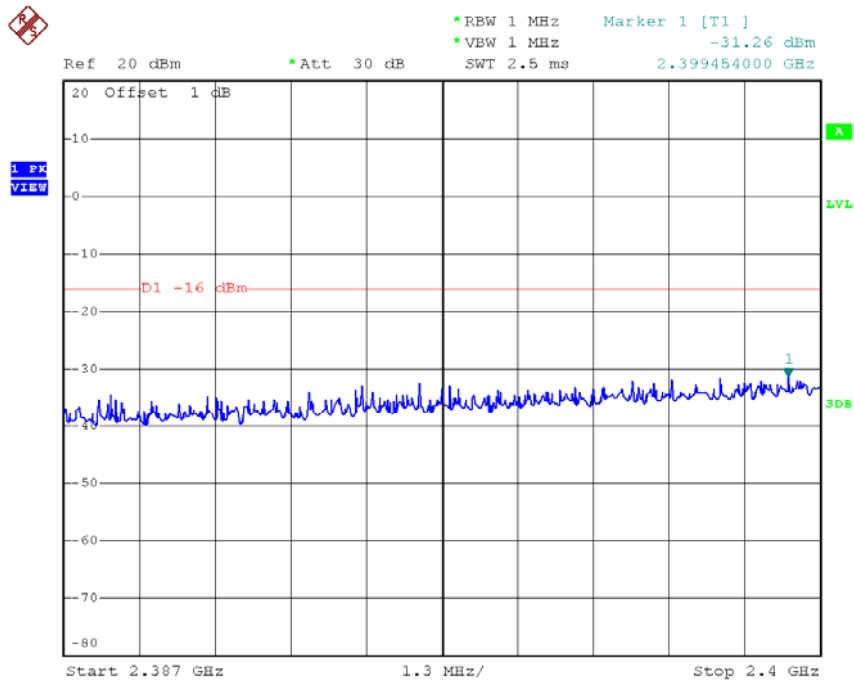

Date: 17.NOV.2015 16:14:12

Low Voltage

CH07 Frequency Band 4 ($2483.5 \text{ MHz} \leq f < 2496.5 \text{ MHz}$)

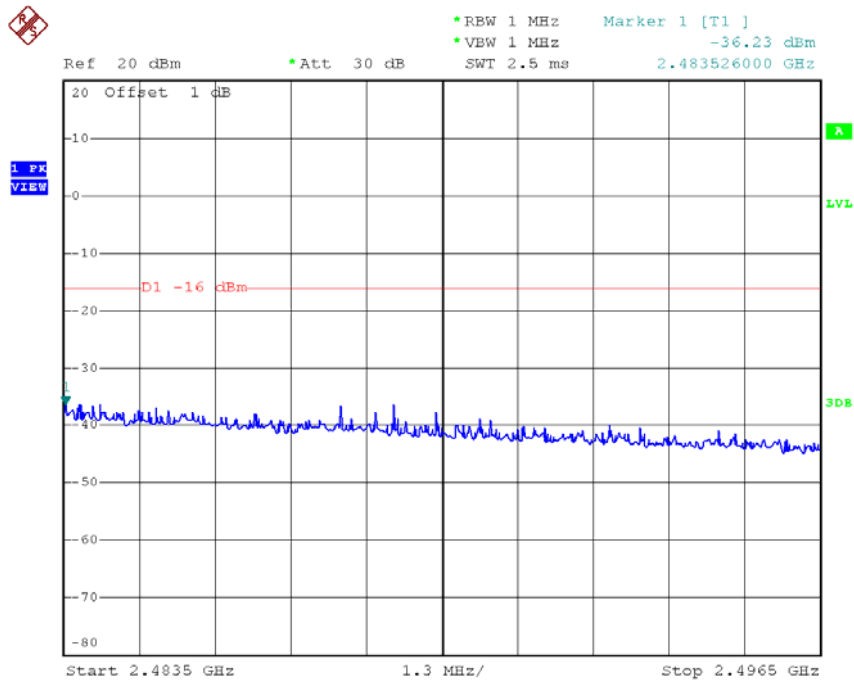

Date: 17.NOV.2015 16:14:21

Low Voltage

CH07 Frequency Band 5 ($2496.5 \text{ MHz} \leq f < 12.5 \text{ GHz}$)

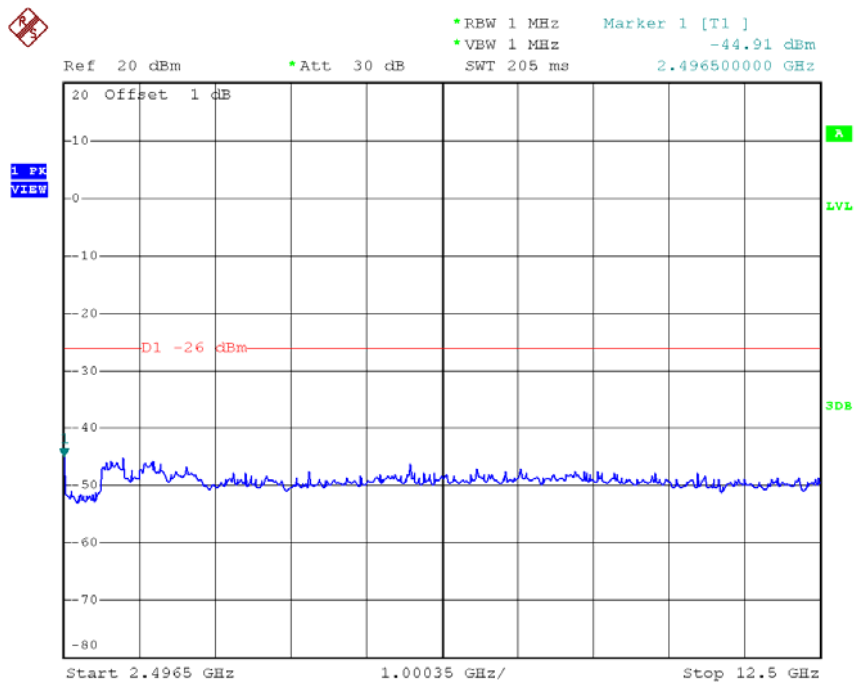

Date: 17.NOV.2015 16:14:32

Low Voltage

CH13 Frequency Band 1 (30 MHz \leq f \leq 1000 MHz)

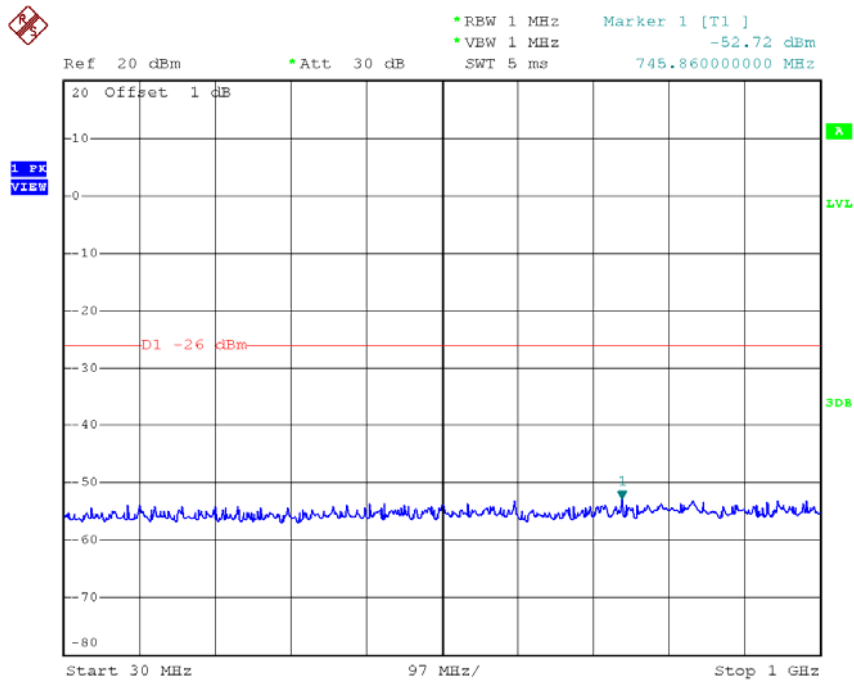

Date: 17.NOV.2015 16:26:50

Low Voltage

CH13 Frequency Band 2 (1000 MHz < f \leq 2387 MHz)

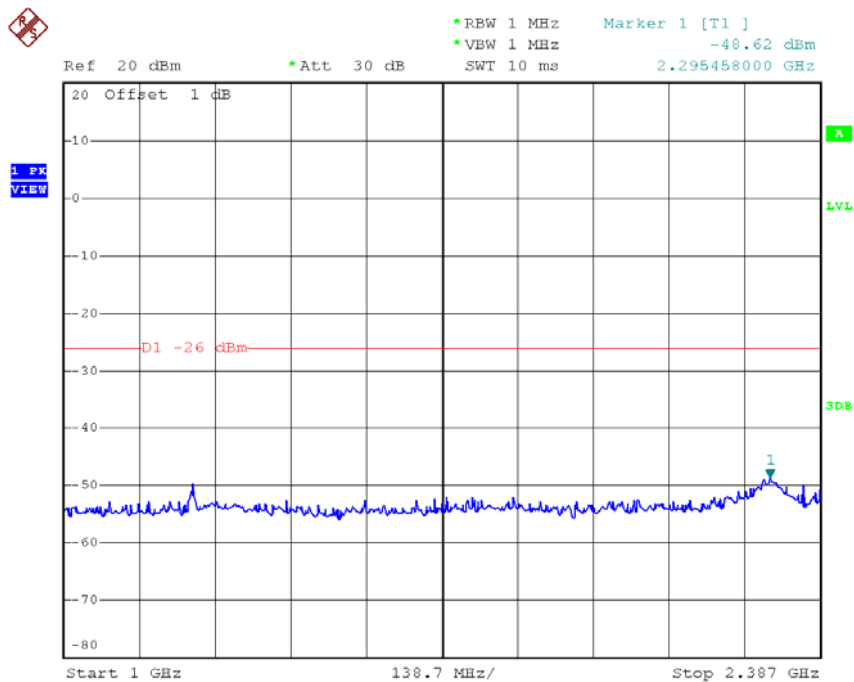

Date: 17.NOV.2015 16:27:00

Low Voltage

CH13 Frequency Band 3 (2387 MHz \cong f < 2400 MHz)

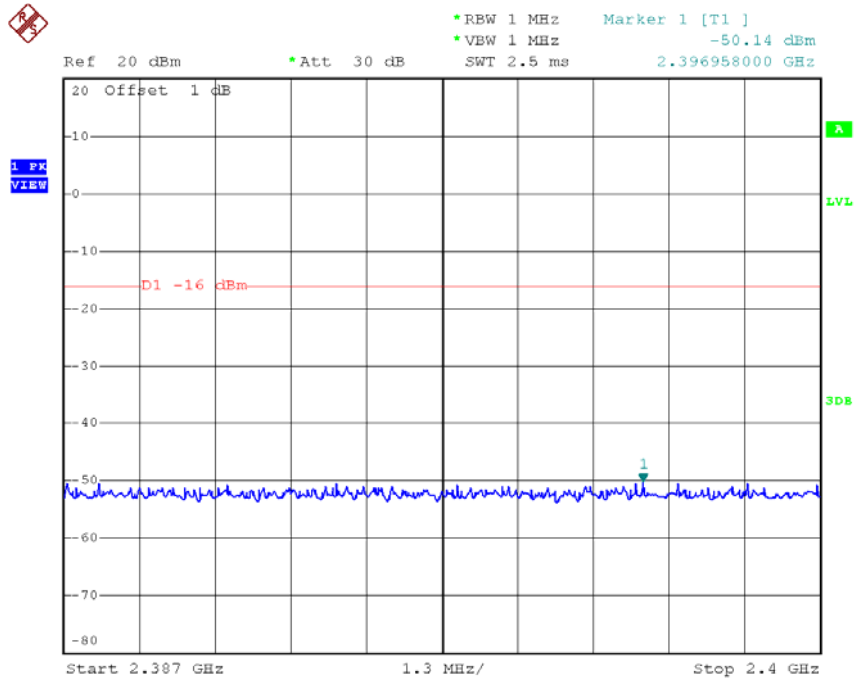

Date: 17.NOV.2015 16:27:10

Low Voltage

CH13 Frequency Band 4 (2483.5 MHz \cong f < 2496.5 MHz)

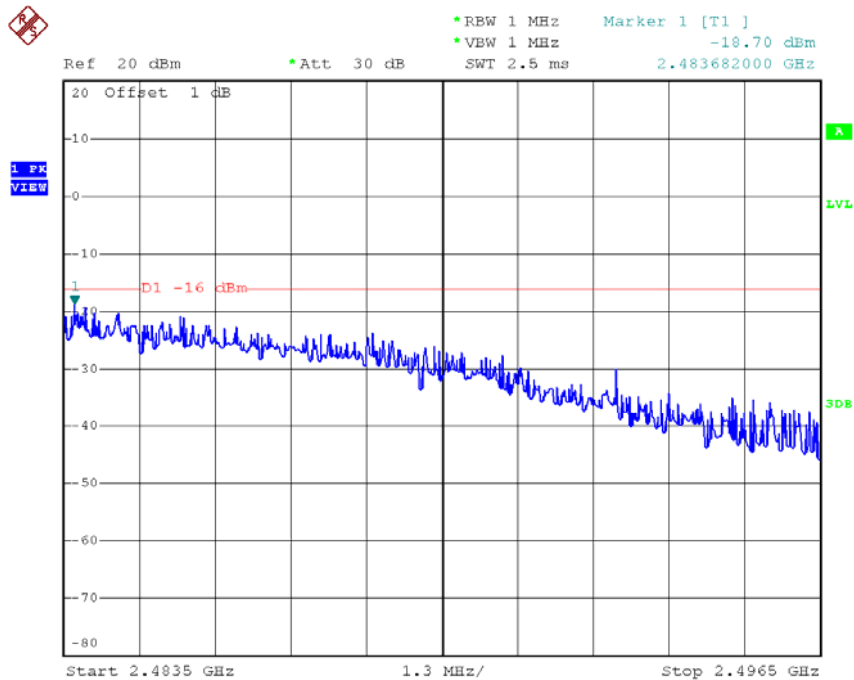

Date: 17.NOV.2015 16:27:19

Low Voltage CH13 Frequency Band 5 (2496.5 MHz ≅ f <12.5 GHz)

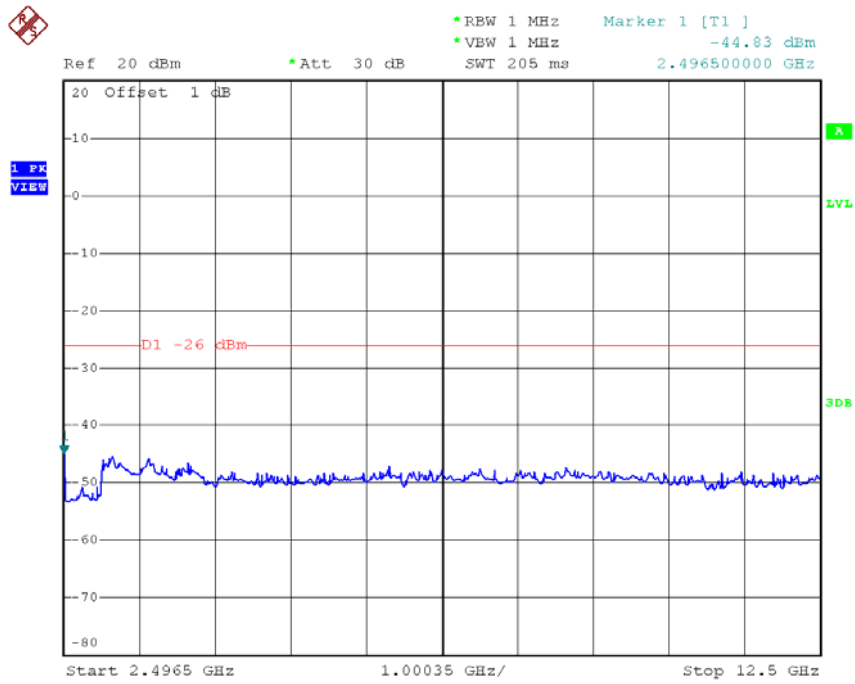

Date: 17.NOV.2015 16:27:29

Test Mode:	802.11n(HT20)/CH01,CH07,CH13
------------	------------------------------

Test Voltage		V	Normal Voltage			Remarks
Test Frequency		MHz	2412	2442	2472	Low/Mid/High of test frequency range
Unwanted Emission Intensity (Power emission within 1MHz bandwidth) (units: μ W)	※ 1	μ W/MHz	0.00570	0.05572	0.00542	Limit \cong 2.5 μ W/MHz (-26 dBm/MHz)
	※ 2	μ W/MHz	0.69343	0.16293	0.01507	Limit \cong 2.5 μ W/MHz (-26 dBm/MHz)
	※ 3	μ W/MHz	10.93956	1.06660	0.00940	Limit \cong 25 μ W/MHz (-16 dBm/MHz)
	※ 4	μ W/MHz	0.00762	0.46774	10.39920	Limit \cong 25 μ W/MHz (-16 dBm/MHz)
	※ 5	μ W/MHz	0.02871	0.03467	0.02951	Limit \cong 2.5 μ W/MHz (-26 dBm/MHz)

Test Voltage		V	High Voltage			Remarks
Test Frequency		MHz	2412	2442	2472	Low/Mid/High of test frequency range
Unwanted Emission Intensity (Power emission within 1MHz bandwidth) (units: μ W)	※ 1	μ W/MHz	0.00568	0.05408	0.00604	Limit \cong 2.5 μ W/MHz (-26 dBm/MHz)
	※ 2	μ W/MHz	1.57761	0.13243	0.01390	Limit \cong 2.5 μ W/MHz (-26 dBm/MHz)
	※ 3	μ W/MHz	7.99834	1.14815	0.01114	Limit \cong 25 μ W/MHz (-16 dBm/MHz)
	※ 4	μ W/MHz	0.00798	0.44978	9.28966	Limit \cong 25 μ W/MHz (-16 dBm/MHz)
	※ 5	μ W/MHz	0.03126	0.03236	0.02582	Limit \cong 2.5 μ W/MHz (-26 dBm/MHz)

Test Voltage		V	Low Voltage			Remarks
Test Frequency		MHz	2412	2442	2472	Low/Mid/High of test frequency range
Unwanted Emission Intensity (Power emission within 1MHz bandwidth) (units: μ W)	※ 1	μ W/MHz	0.00721	0.05224	0.83560	Limit \cong 2.5 μ W/MHz (-26 dBm/MHz)
	※ 2	μ W/MHz	0.30690	0.14757	0.01334	Limit \cong 2.5 μ W/MHz (-26 dBm/MHz)
	※ 3	μ W/MHz	8.49180	1.01859	0.01069	Limit \cong 25 μ W/MHz (-16 dBm/MHz)
	※ 4	μ W/MHz	0.00774	0.37497	9.61612	Limit \cong 25 μ W/MHz (-16 dBm/MHz)
	※ 5	μ W/MHz	0.03540	0.04207	0.06607	Limit \cong 2.5 μ W/MHz (-26 dBm/MHz)

Normal Voltage
CH01 Frequency Band 3 (2387 MHz \cong f < 2400 MHz)

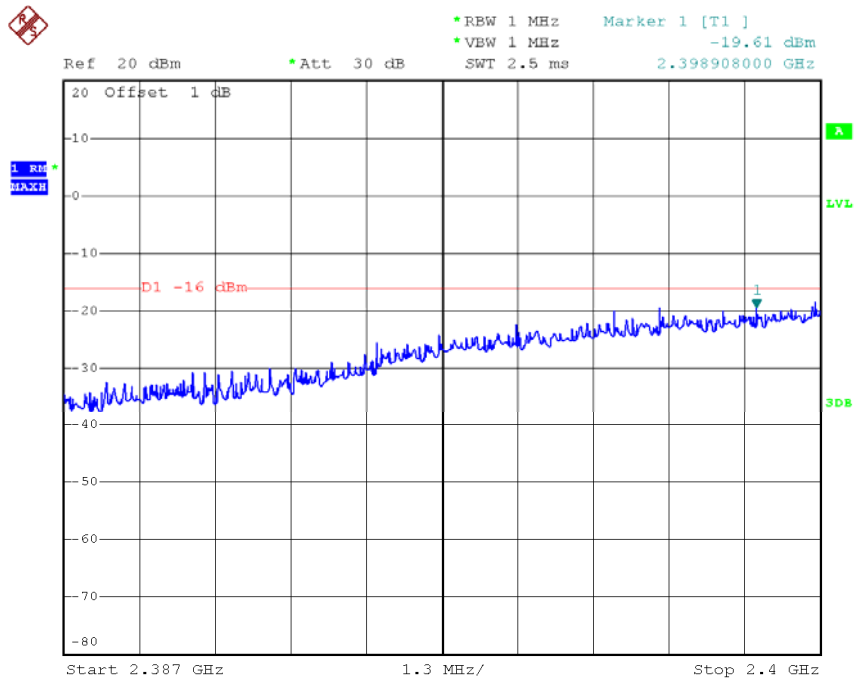

Date: 17.NOV.2015 17:07:33

Normal Voltage
CH01 Frequency Band 4 (2483.5 MHz \cong f < 2496.5 MHz)

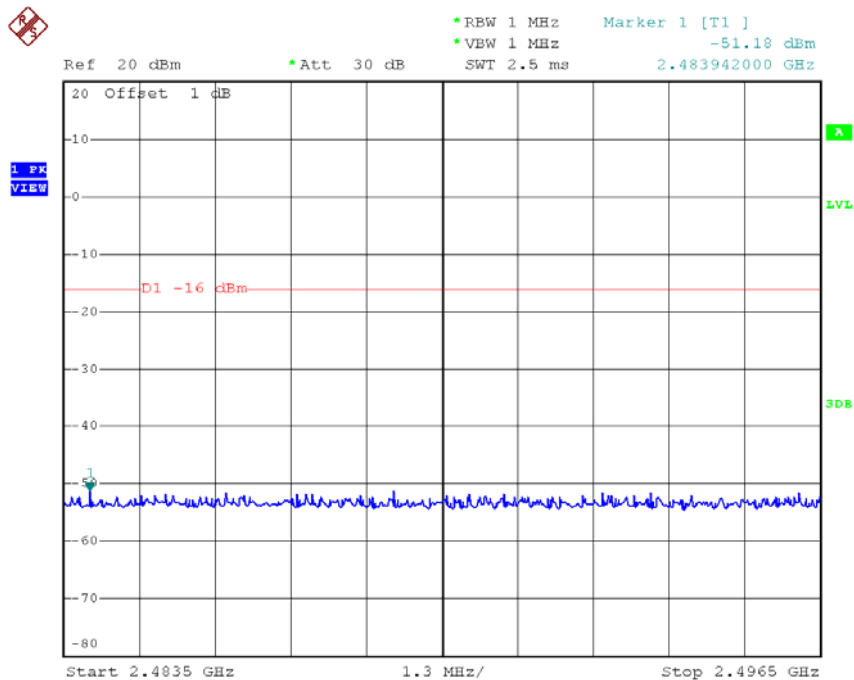

Date: 17.NOV.2015 17:11:57

Normal Voltage
CH01 Frequency Band 5 (2496.5 MHz \leq f < 12.5 GHz)

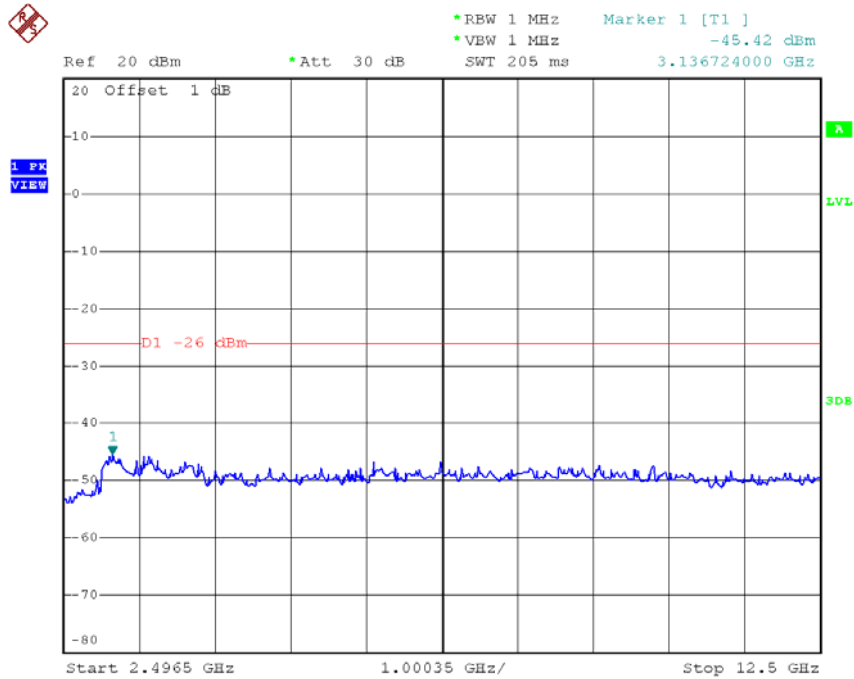

Date: 17.NOV.2015 17:12:08

Normal Voltage
CH07 Frequency Band 1 (30 MHz \leq f \leq 1000 MHz)

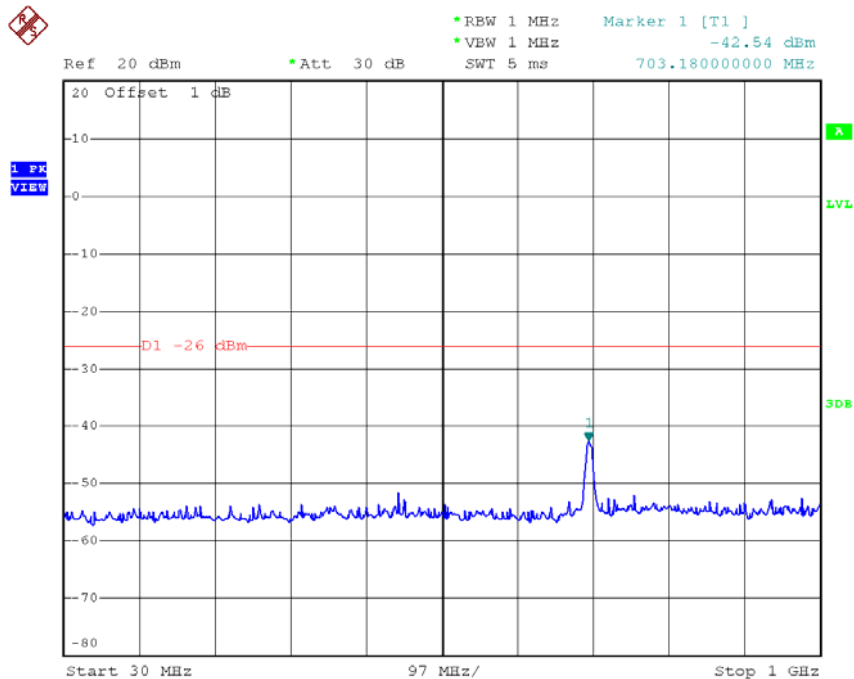

Date: 17.NOV.2015 17:27:26

Normal Voltage
CH07 Frequency Band 2 (1000 MHz < f ≤ 2387 MHz)

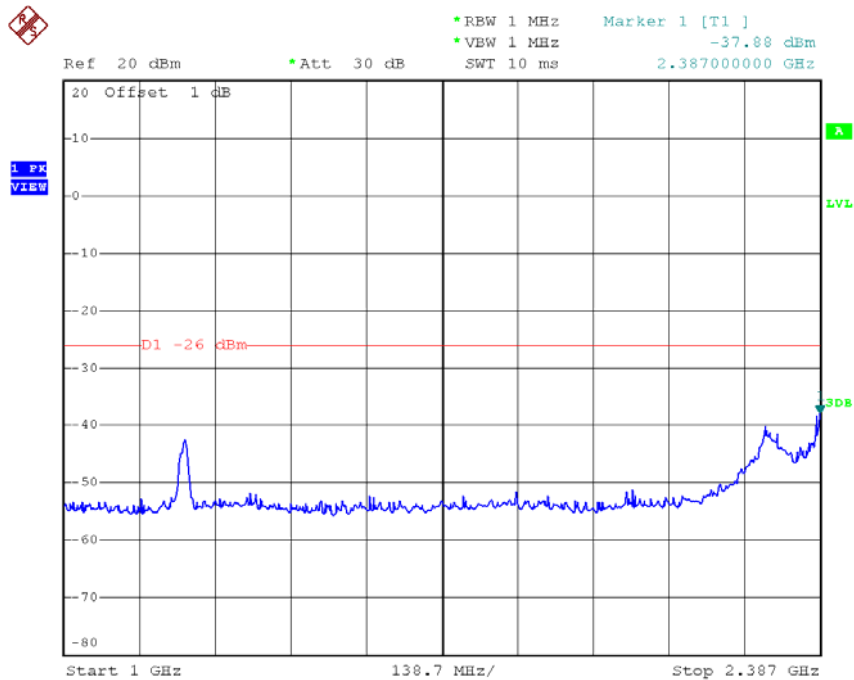

Date: 17.NOV.2015 17:27:37

Normal Voltage
CH07 Frequency Band 3 (2387 MHz ≤ f < 2400 MHz)

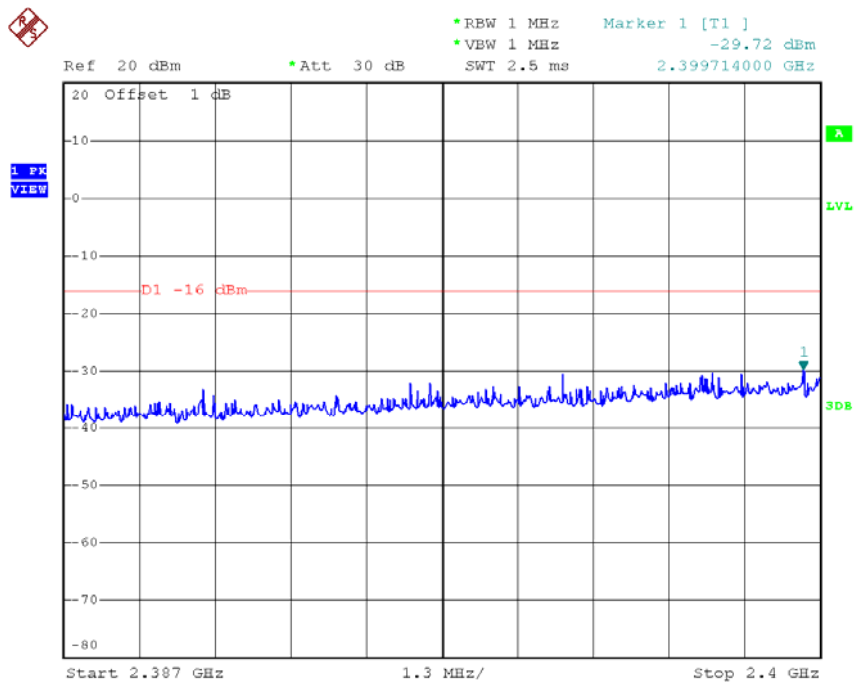

Date: 17.NOV.2015 17:27:47

Normal Voltage

CH07 Frequency Band 4 (2483.5 MHz \cong f < 2496.5 MHz)

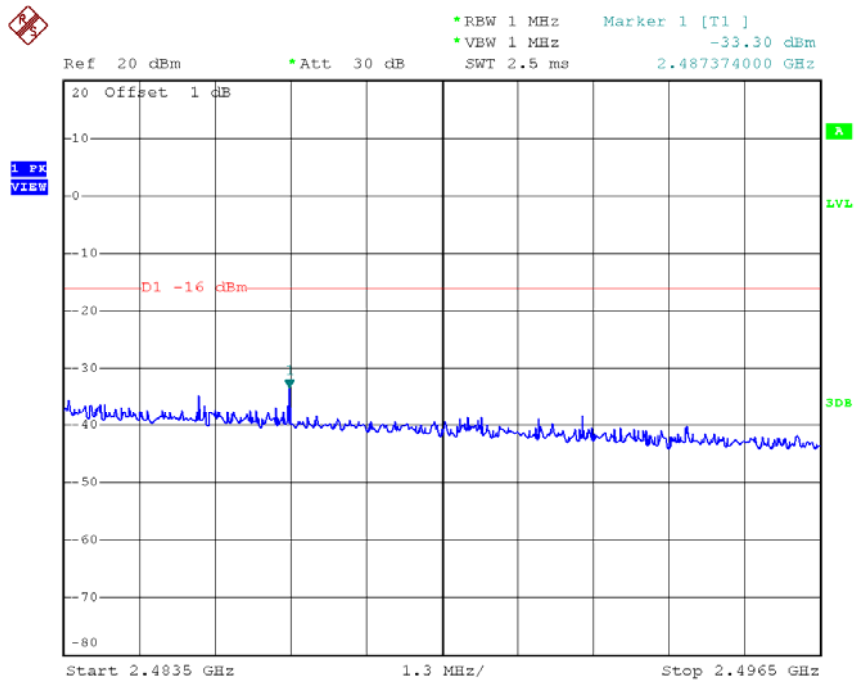

Date: 17.NOV.2015 17:27:57

Normal Voltage

CH07 Frequency Band 5 (2496.5 MHz \cong f < 12.5 GHz)

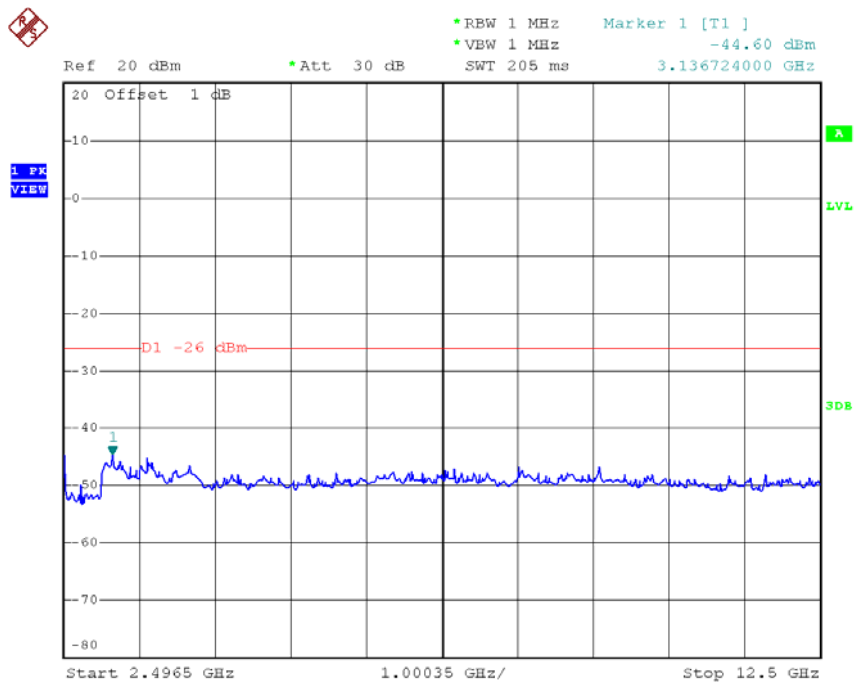

Date: 17.NOV.2015 17:28:08

Normal Voltage CH13 Frequency Band 1 (30 MHz \leq f \leq 1000 MHz)

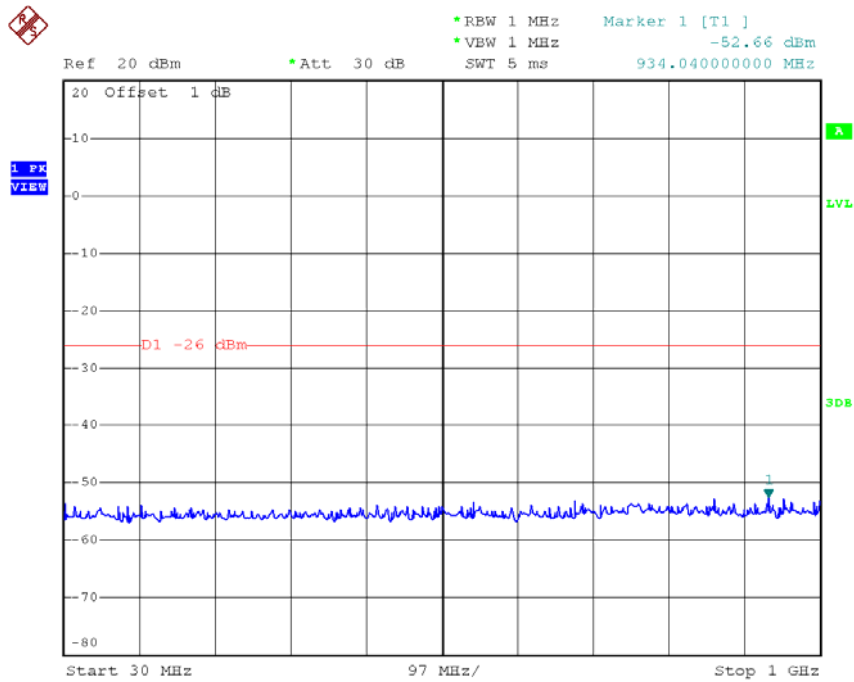

Date: 17.NOV.2015 18:02:20

Normal Voltage CH13 Frequency Band 2 (1000 MHz < f \leq 2387 MHz)

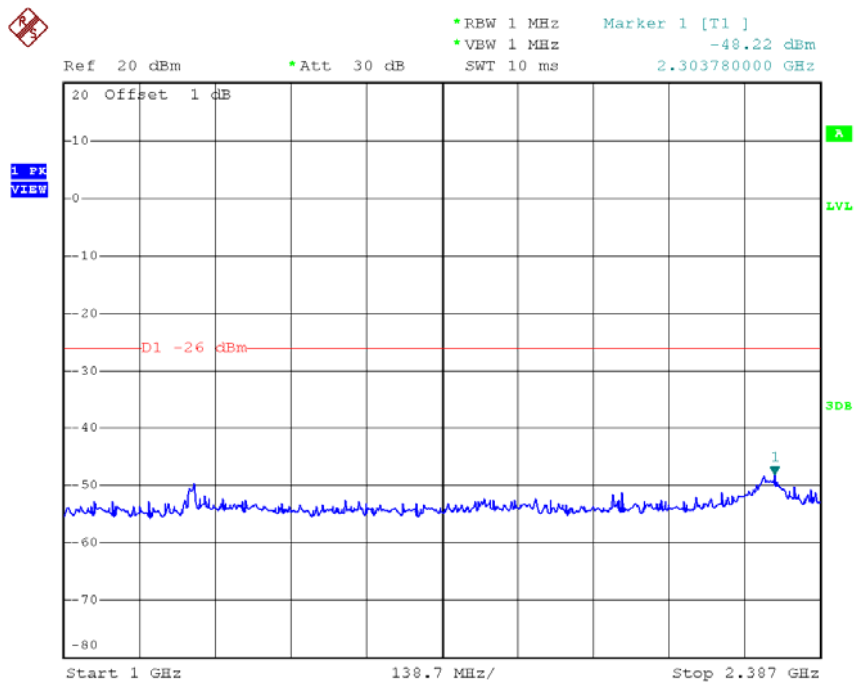

Date: 17.NOV.2015 18:02:31

Normal Voltage
CH13 Frequency Band 3 (2387 MHz \cong f < 2400 MHz)

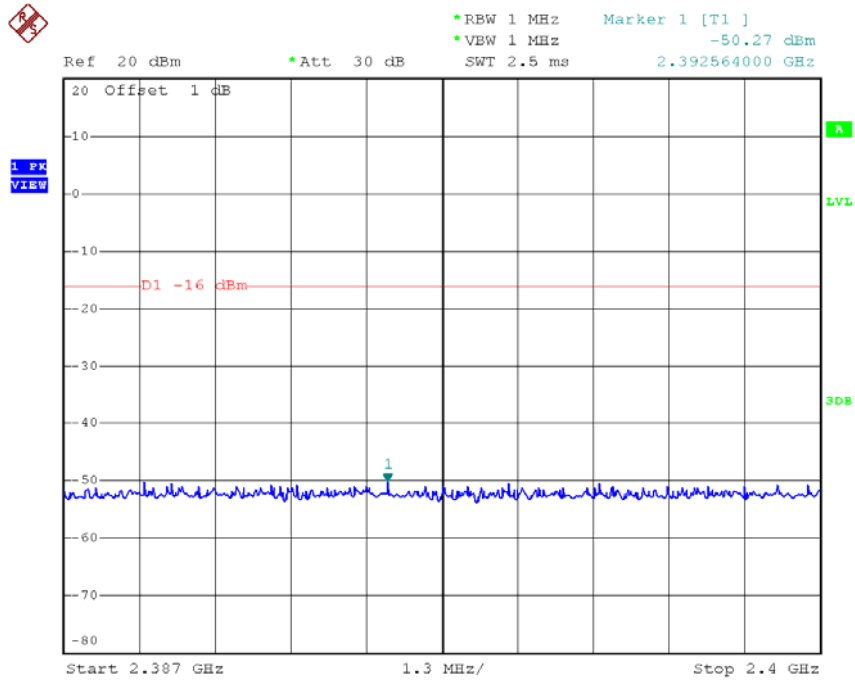

Date: 17.NOV.2015 18:02:42

Normal Voltage
CH13 Frequency Band 4 (2483.5 MHz \cong f < 2496.5 MHz)

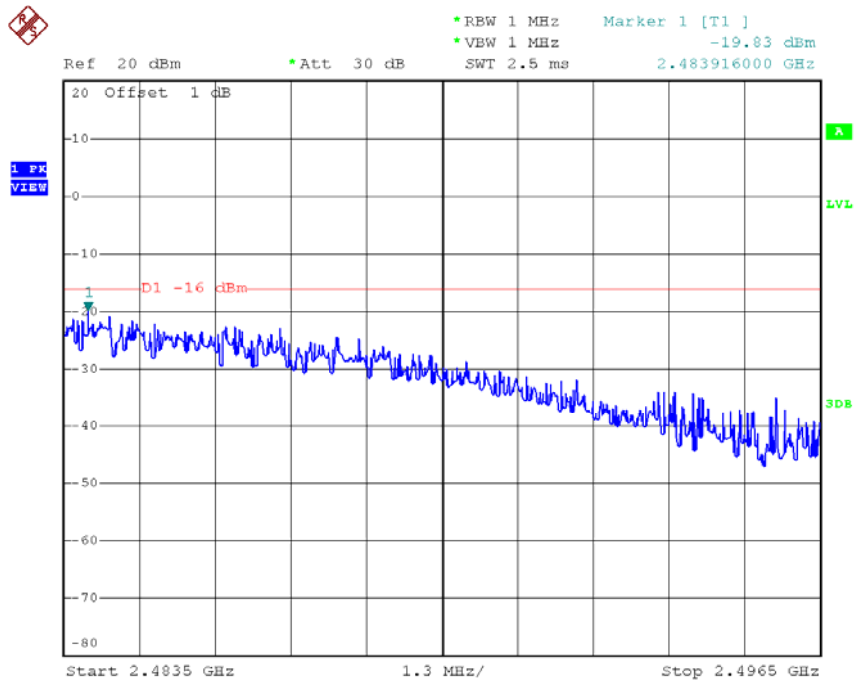

Date: 17.NOV.2015 18:02:52

Normal Voltage
CH13 Frequency Band 5 (2496.5 MHz \cong f <12.5 GHz)

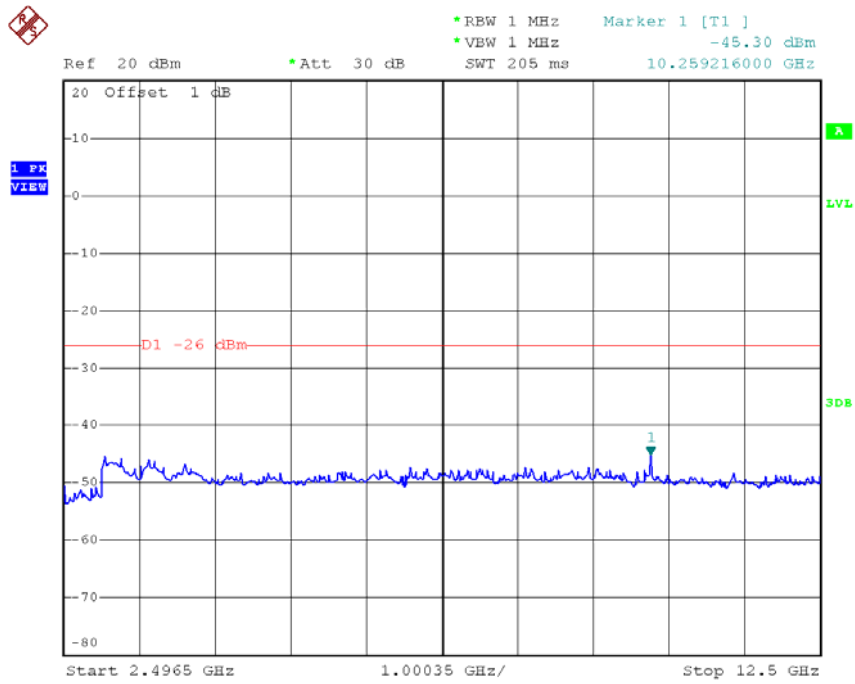

Date: 17.NOV.2015 18:03:03

High Voltage

CH01 Frequency Band 1 (30 MHz \leq f \leq 1000 MHz)

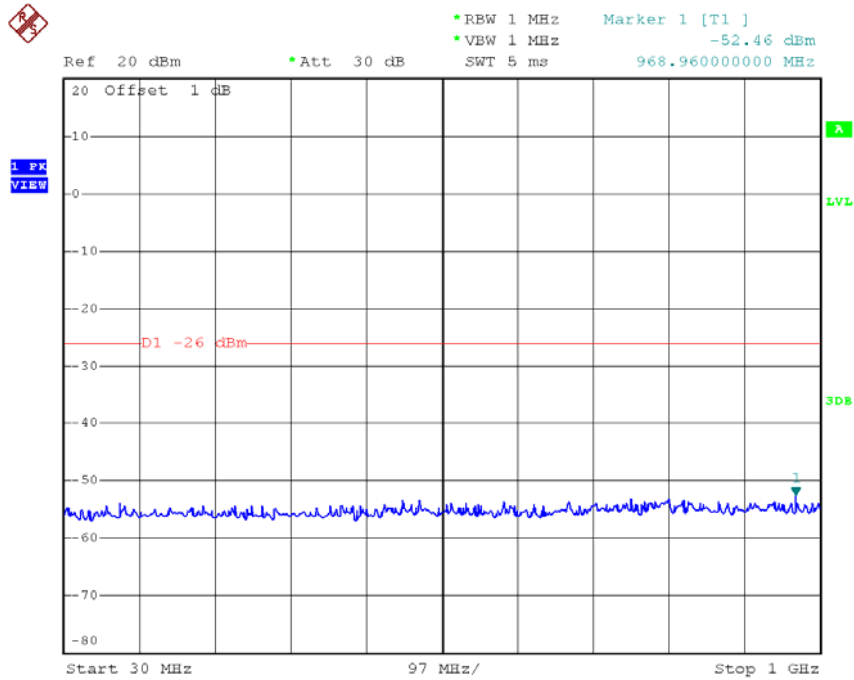

Date: 17.NOV.2015 17:08:40

High Voltage

CH01 Frequency Band 2 (1000 MHz < f \leq 2387 MHz)

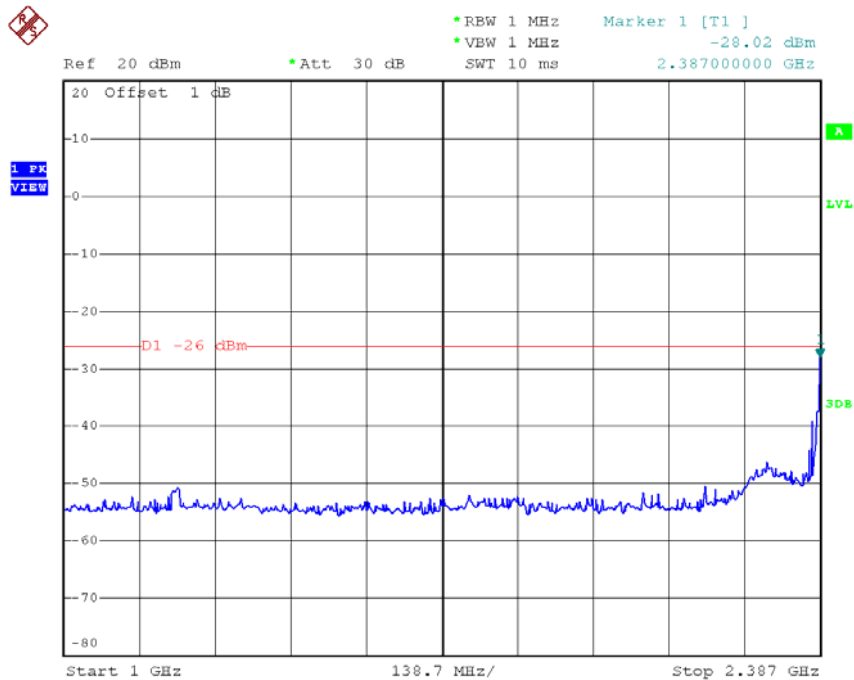

Date: 17.NOV.2015 17:08:51

High Voltage CH01 Frequency Band 3 (2387 MHz \cong f < 2400 MHz)

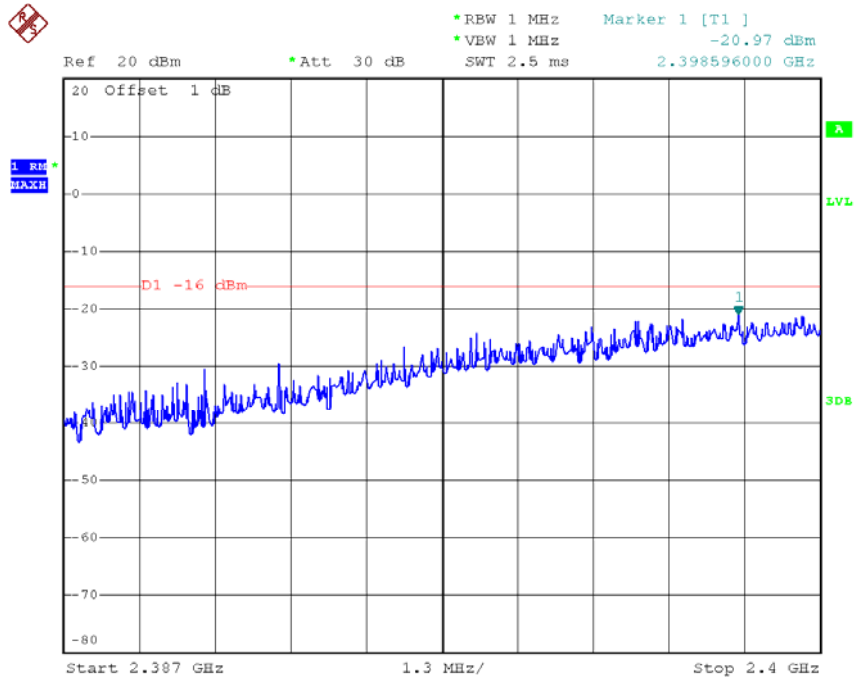

Date: 17.NOV.2015 17:08:07

High Voltage CH01 Frequency Band 4 (2483.5 MHz \cong f < 2496.5 MHz)

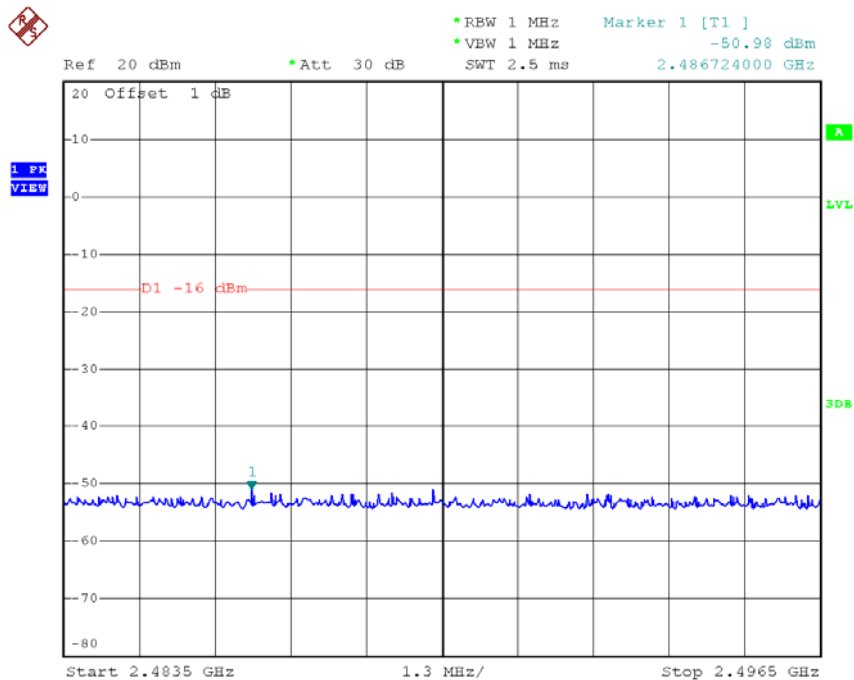

Date: 17.NOV.2015 17:09:12

High Voltage CH01 Frequency Band 5 (2496.5 MHz \leq f < 12.5 GHz)

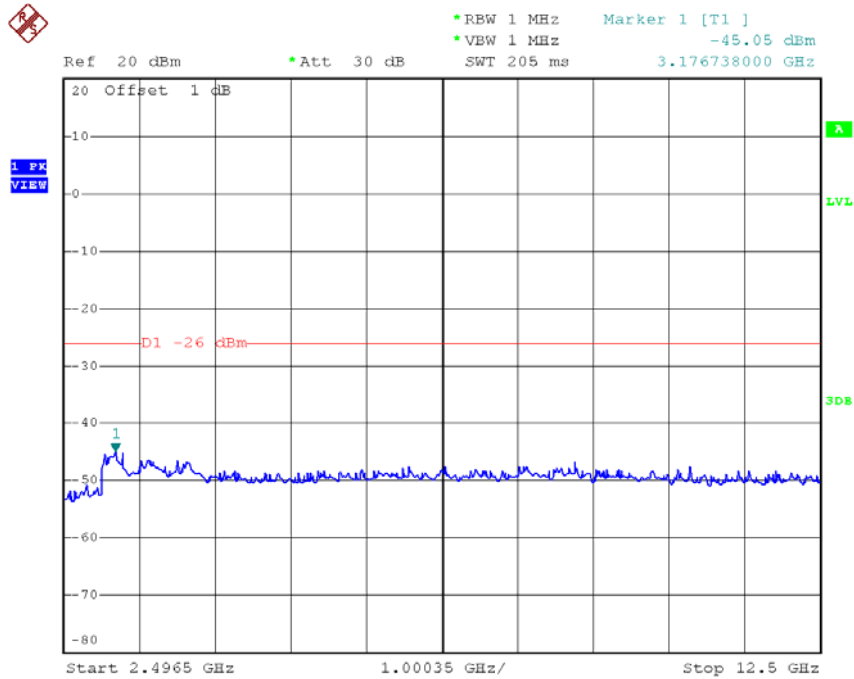

Date: 17.NOV.2015 17:09:23

High Voltage CH07 Frequency Band 1 (30 MHz \leq f \leq 1000 MHz)

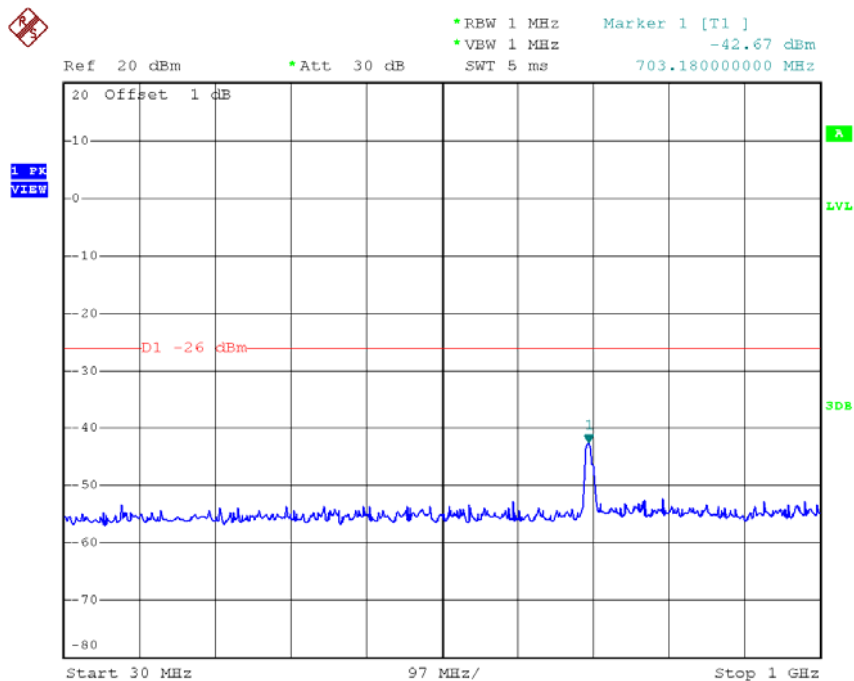

Date: 17.NOV.2015 17:24:39

High Voltage CH07 Frequency Band 2 (1000 MHz < f ≤ 2387 MHz)

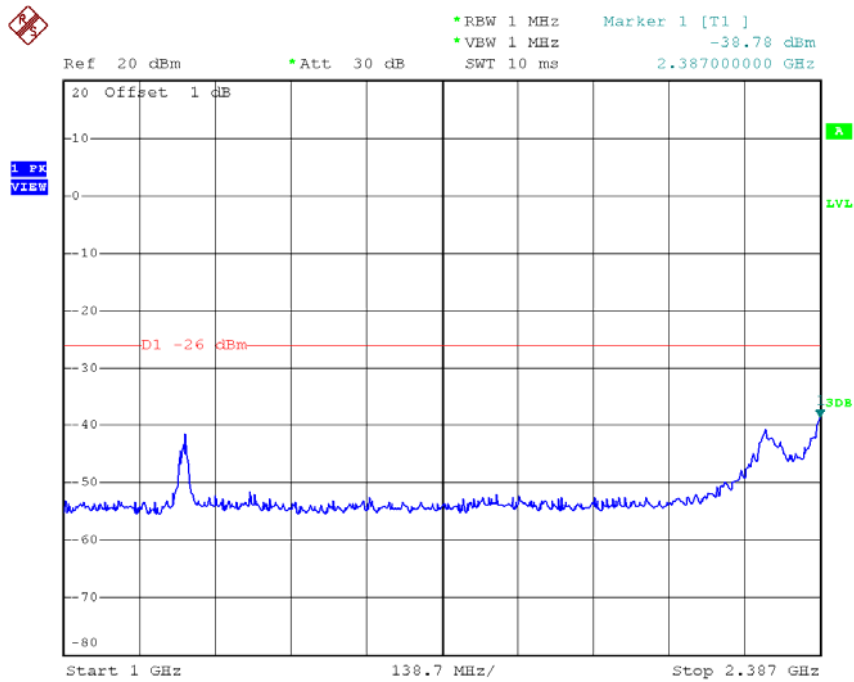

Date: 17.NOV.2015 17:24:50

High Voltage CH07 Frequency Band 3 (2387 MHz ≤ f < 2400 MHz)

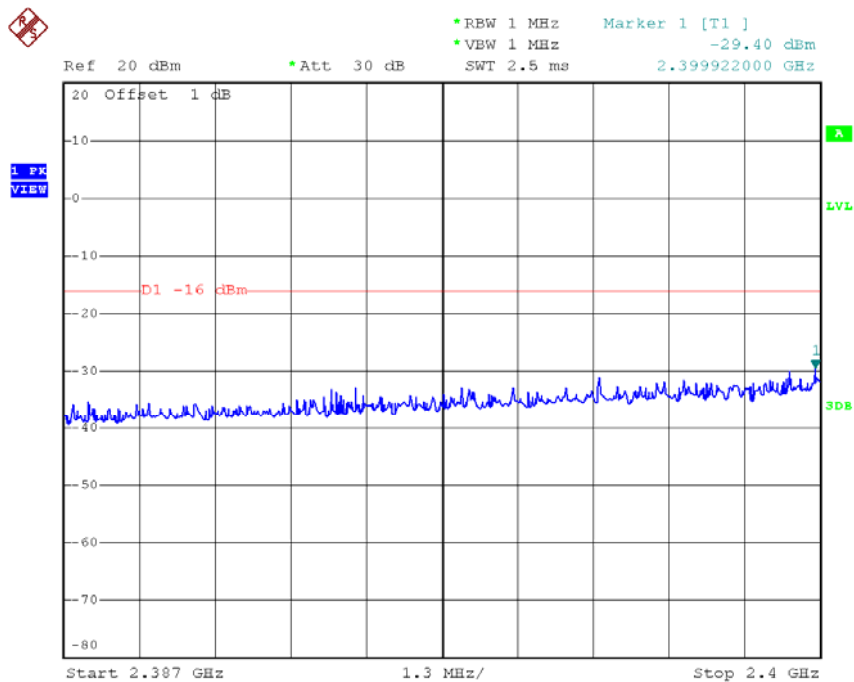

Date: 17.NOV.2015 17:25:01

High Voltage

CH07 Frequency Band 4 ($2483.5 \text{ MHz} \leq f < 2496.5 \text{ MHz}$)

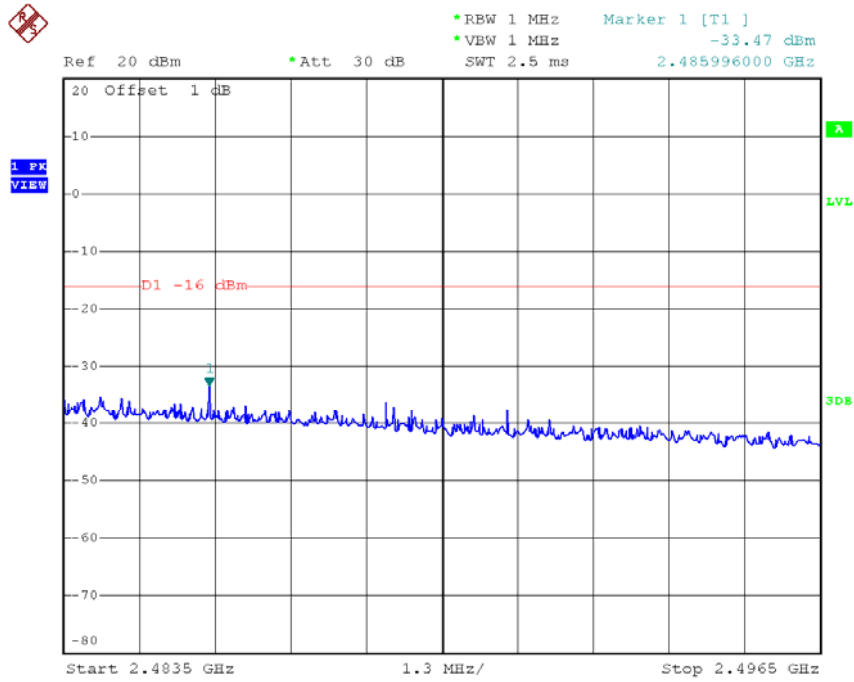

Date: 17.NOV.2015 17:25:11

High Voltage

CH07 Frequency Band 5 ($2496.5 \text{ MHz} \leq f < 12.5 \text{ GHz}$)

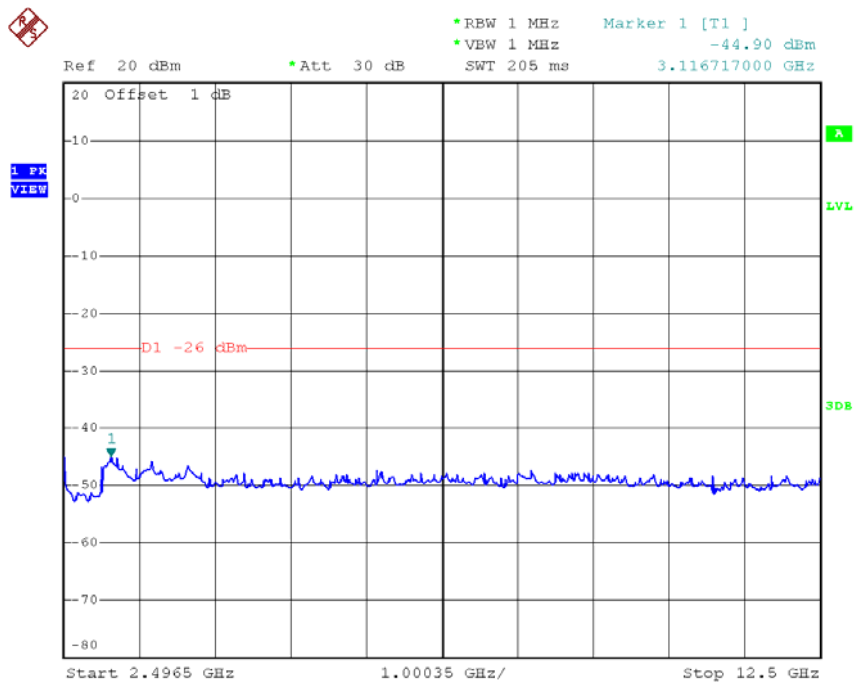

Date: 17.NOV.2015 17:25:22

High Voltage

CH13 Frequency Band 1 (30 MHz \leq f \leq 1000 MHz)

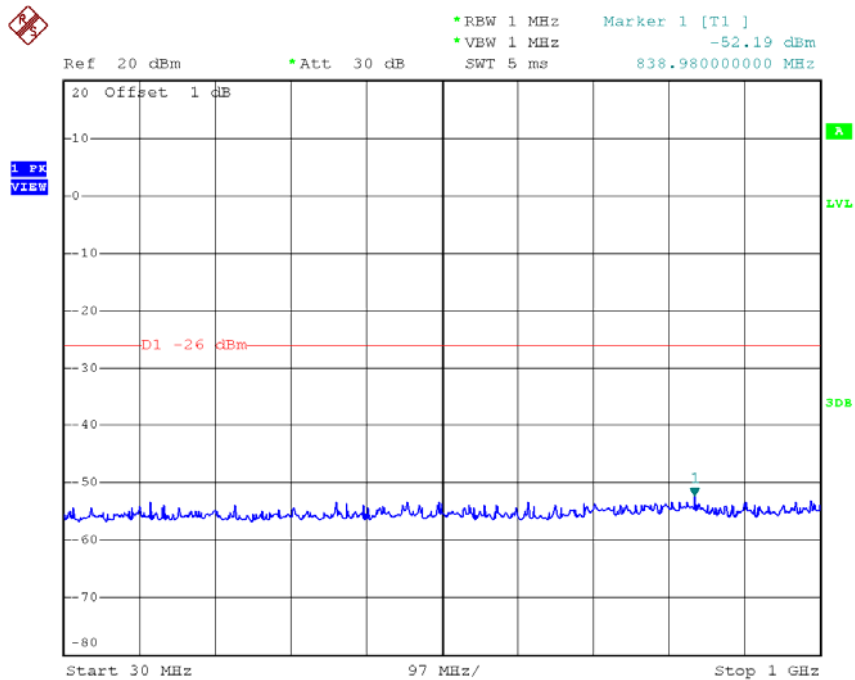

Date: 17.NOV.2015 17:59:26

High Voltage

CH13 Frequency Band 2 (1000 MHz < f \leq 2387 MHz)

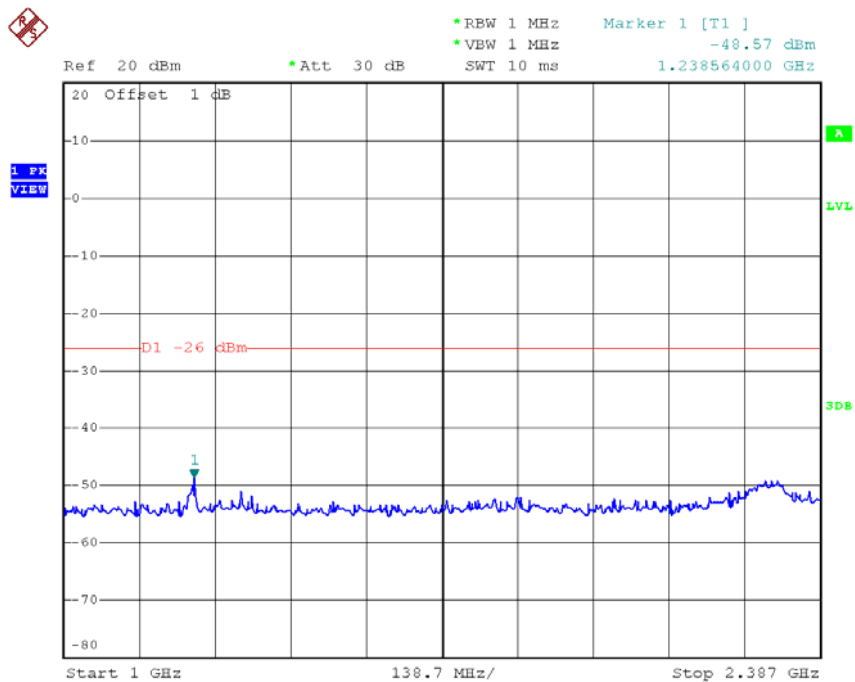

Date: 17.NOV.2015 17:59:38

High Voltage

CH13 Frequency Band 3 (2387 MHz \cong f < 2400 MHz)

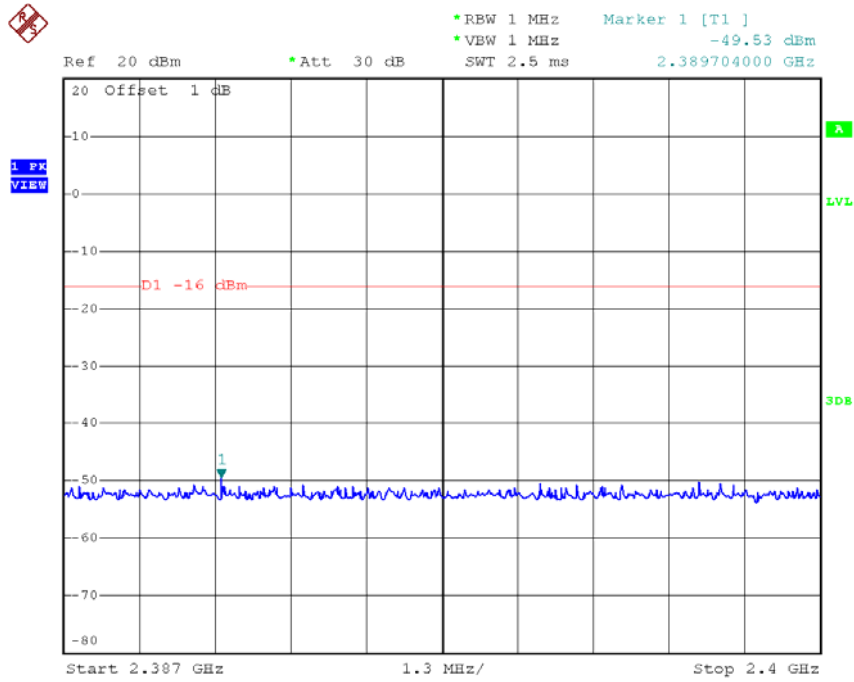

Date: 17.NOV.2015 17:59:49

High Voltage

CH13 Frequency Band 4 (2483.5 MHz \cong f < 2496.5 MHz)

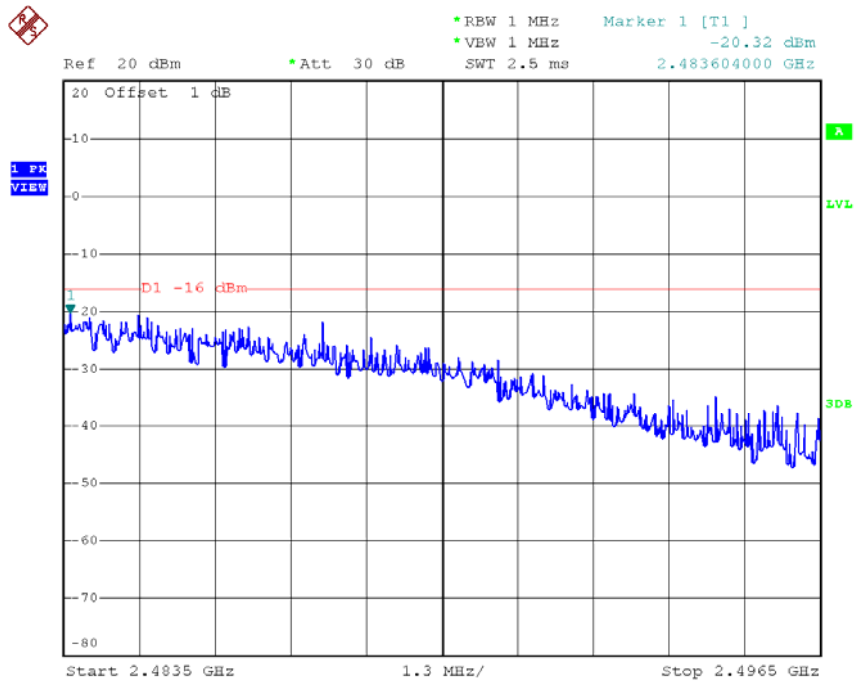

Date: 17.NOV.2015 17:59:58

High Voltage

CH13 Frequency Band 5 (2496.5 MHz \cong f < 12.5 GHz)

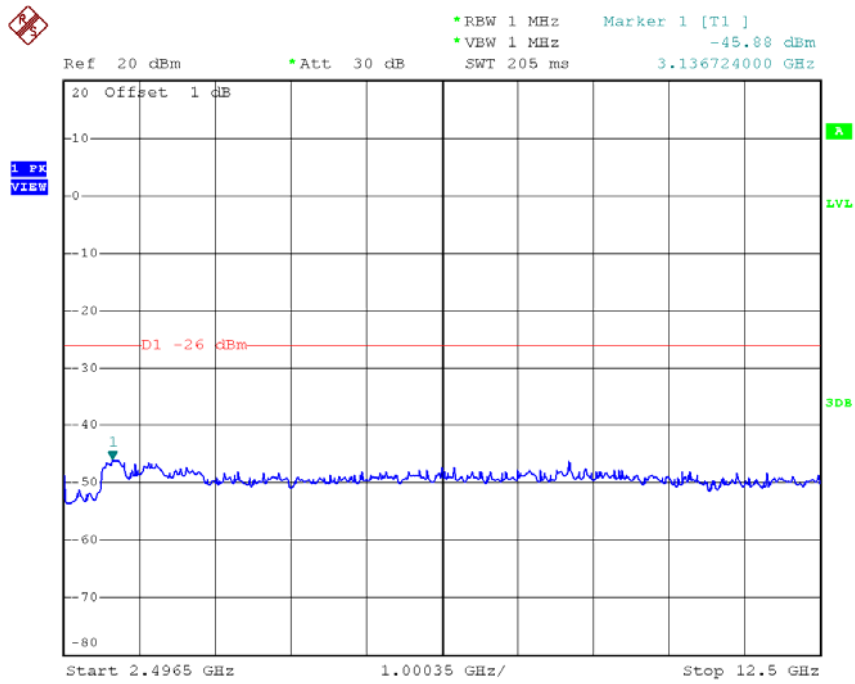

Date: 17.NOV.2015 18:00:09

Low Voltage

CH01 Frequency Band 1 (30 MHz \leq f \leq 1000 MHz)

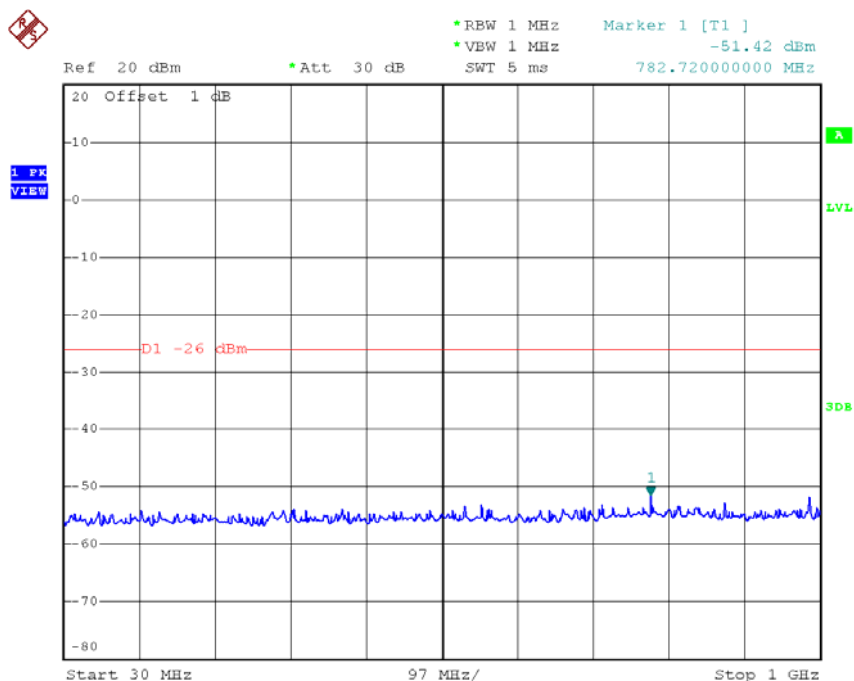

Date: 17.NOV.2015 17:14:14

Low Voltage

CH01 Frequency Band 2 (1000 MHz < f \leq 2387 MHz)

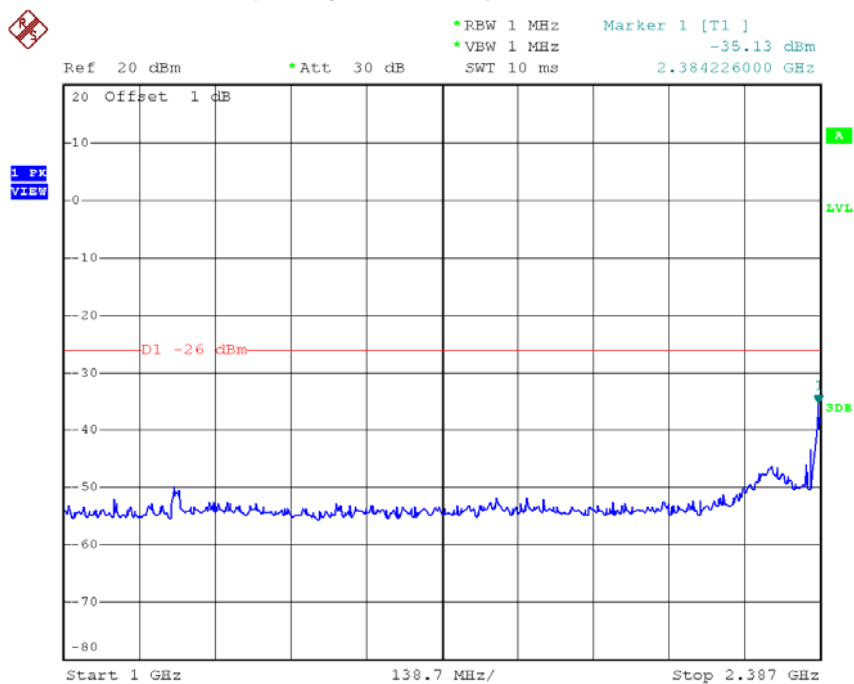

Date: 17.NOV.2015 17:14:25

Low Voltage CH01 Frequency Band 3 (2387 MHz \cong f < 2400 MHz)

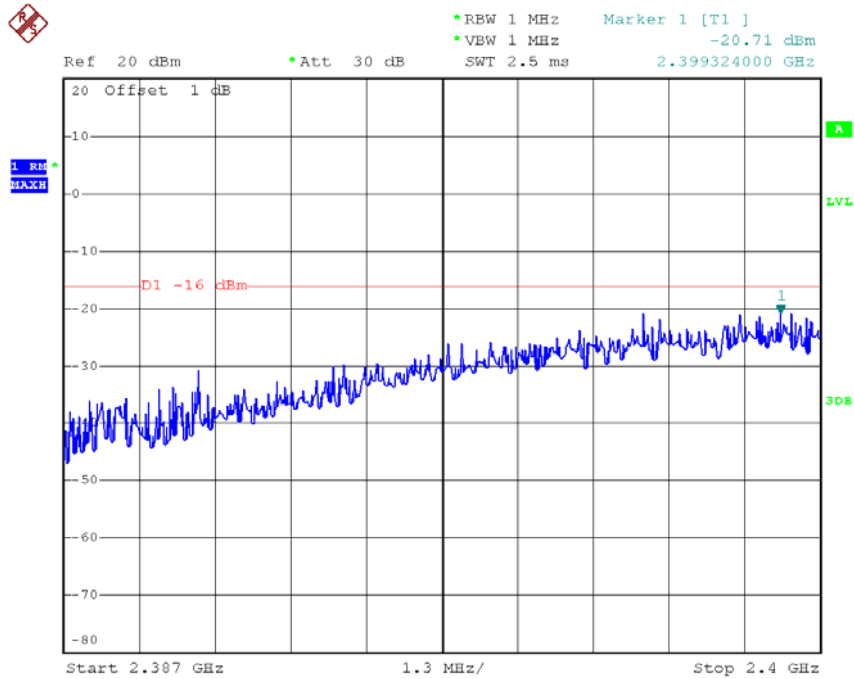

Date: 17.NOV.2015 17:07:50

Low Voltage CH01 Frequency Band 4 (2483.5 MHz \cong f < 2496.5 MHz)

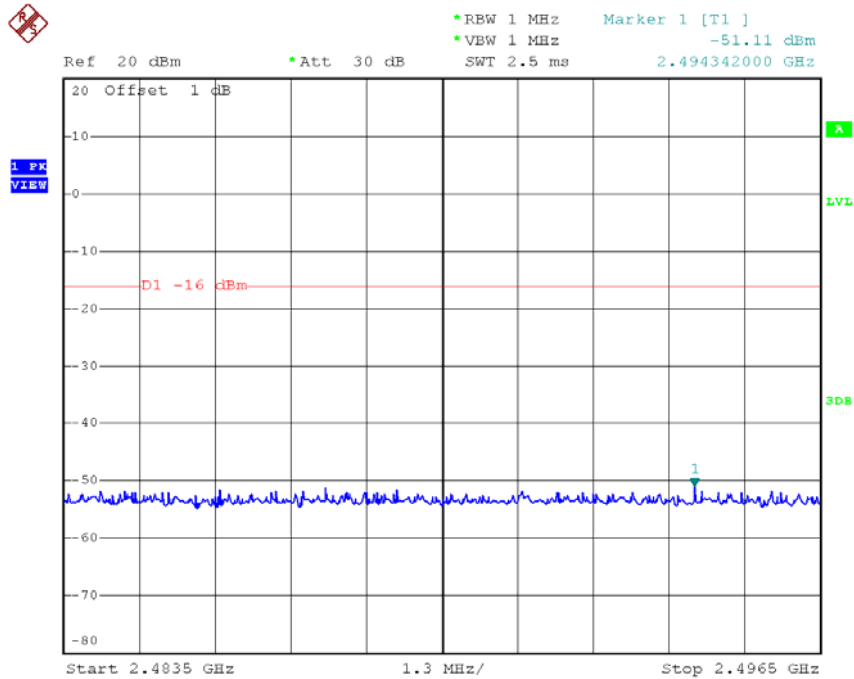

Date: 17.NOV.2015 17:14:46

Low Voltage CH01 Frequency Band 5 (2496.5 MHz \leq f < 12.5 GHz)

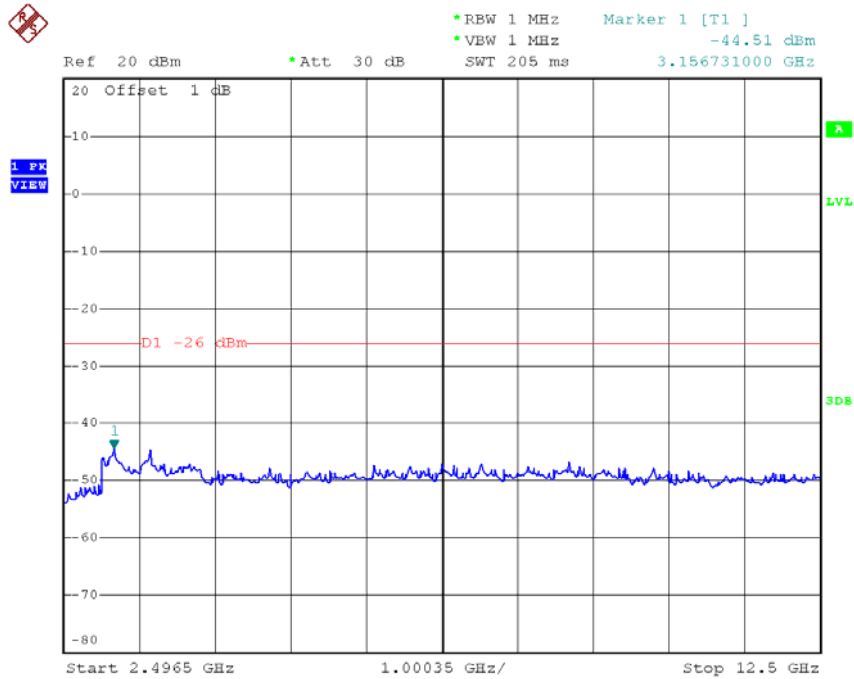

Date: 17.NOV.2015 17:14:57

Low Voltage CH07 Frequency Band 1 (30 MHz \leq f \leq 1000 MHz)

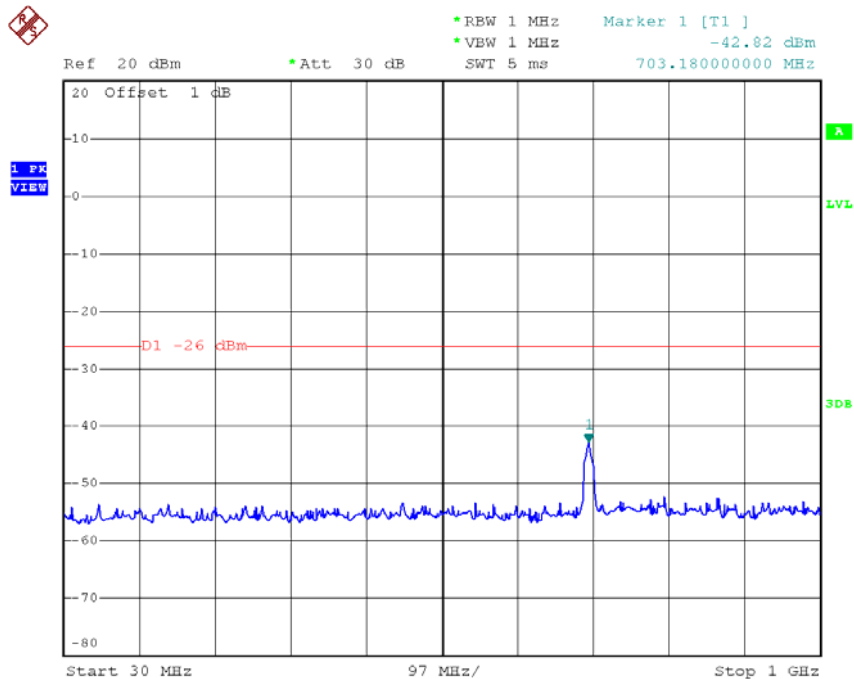

Date: 17.NOV.2015 17:30:10

Low Voltage

CH07 Frequency Band 2 (1000 MHz < f ≤ 2387 MHz)

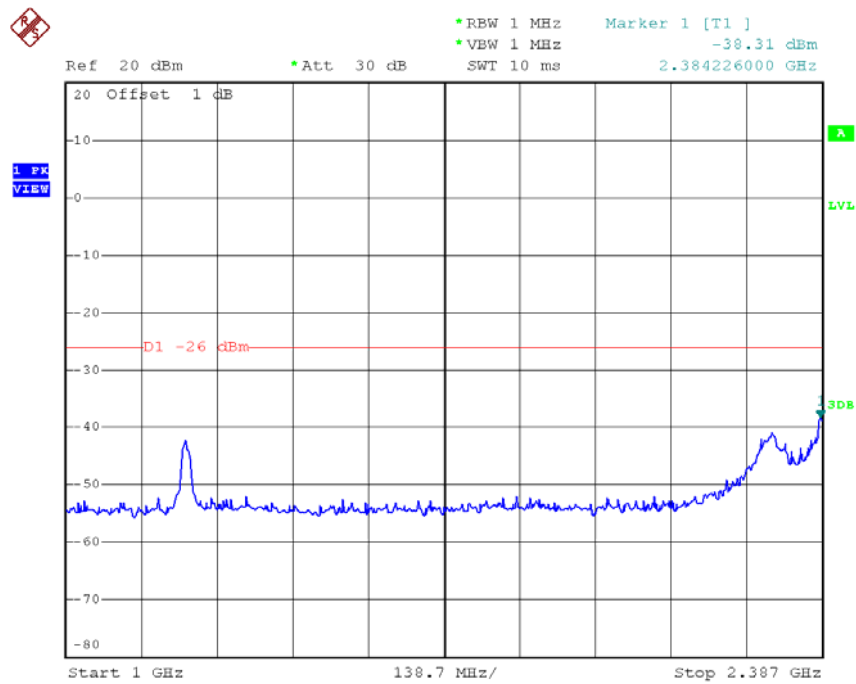

Date: 17.NOV.2015 17:30:21

Low Voltage

CH07 Frequency Band 3 (2387 MHz ≤ f < 2400 MHz)

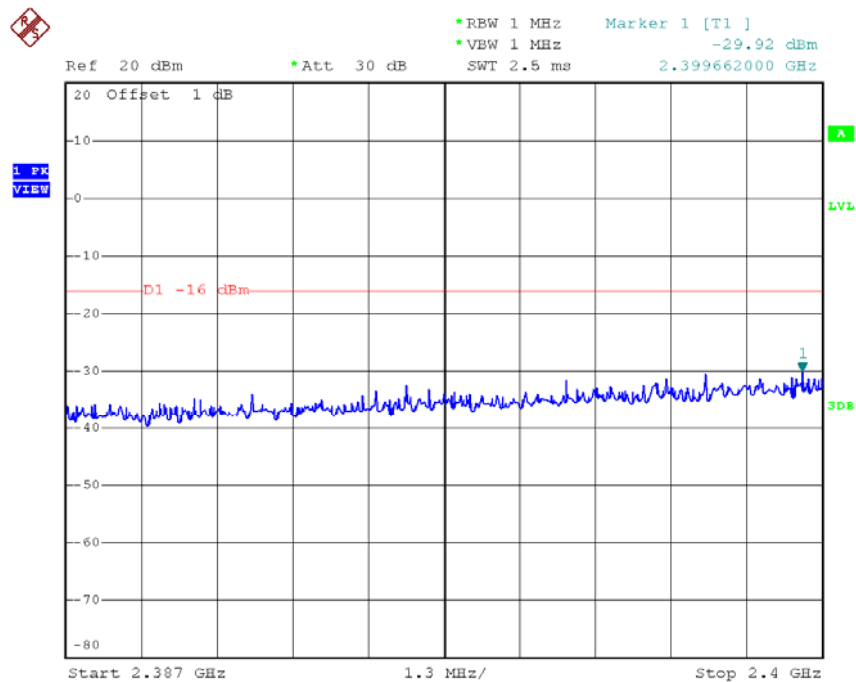

Date: 17.NOV.2015 17:30:32

Low Voltage

CH07 Frequency Band 4 ($2483.5 \text{ MHz} \leq f < 2496.5 \text{ MHz}$)

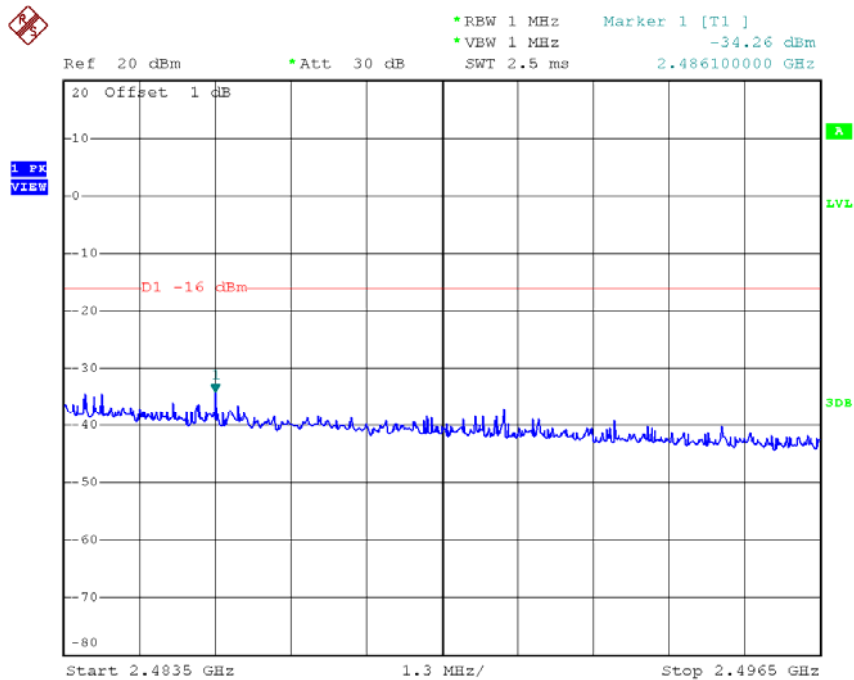

Date: 17.NOV.2015 17:30:42

Low Voltage

CH07 Frequency Band 5 ($2496.5 \text{ MHz} \leq f < 12.5 \text{ GHz}$)

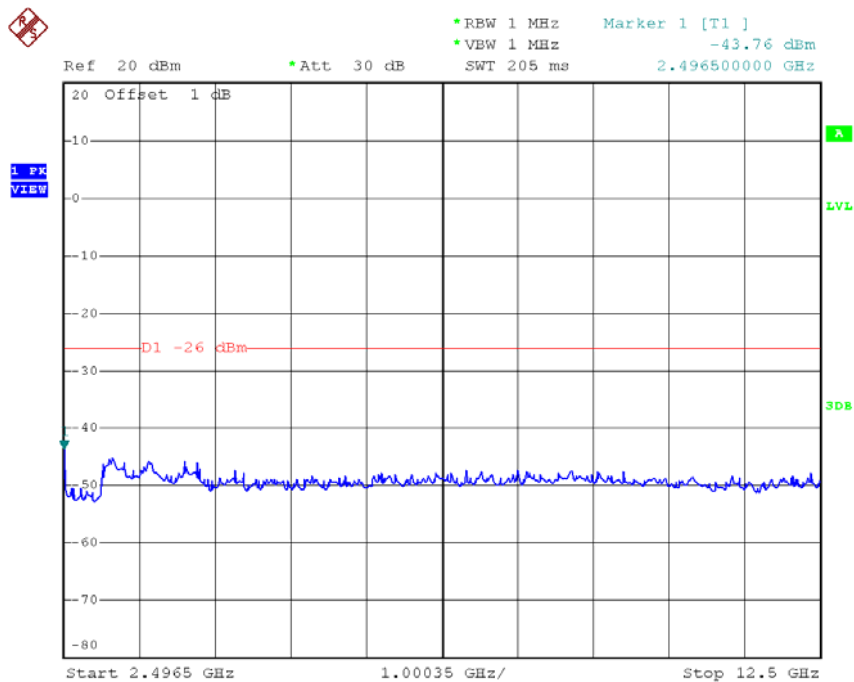

Date: 17.NOV.2015 17:30:53

Low Voltage

CH13 Frequency Band 1 (30 MHz \leq f \leq 1000 MHz)

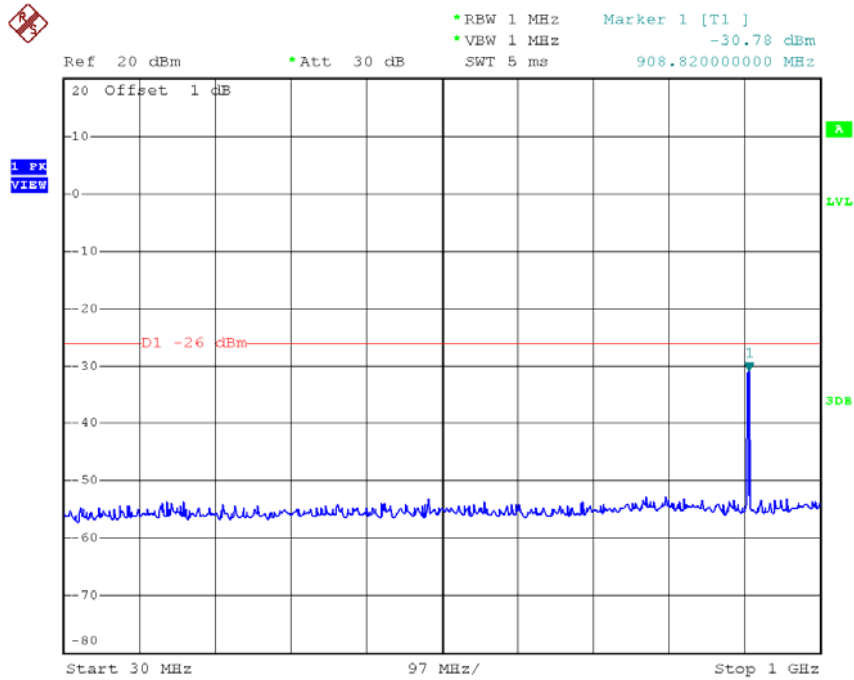

Date: 17.NOV.2015 18:05:04

Low Voltage

CH13 Frequency Band 2 (1000 MHz < f \leq 2387 MHz)

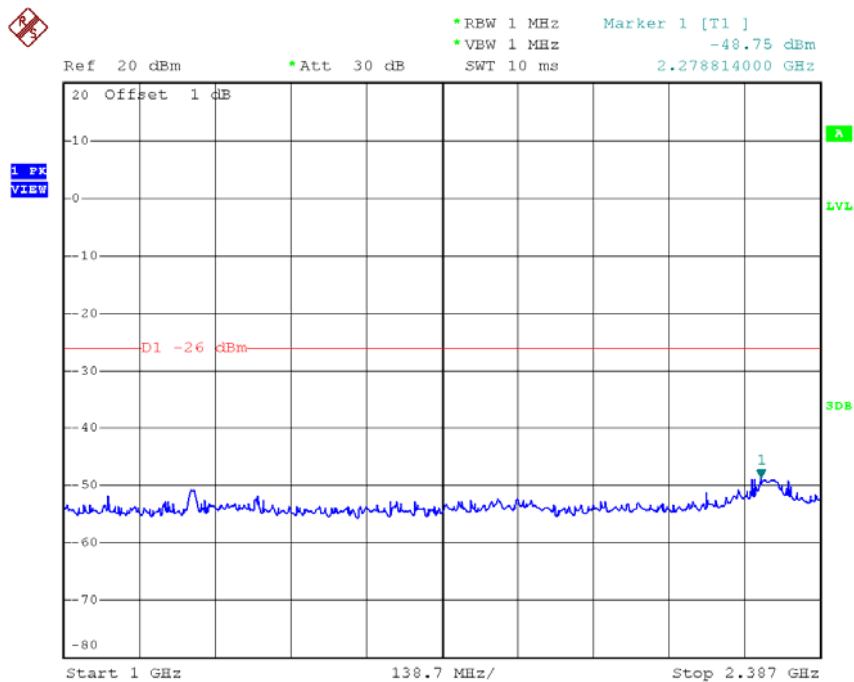

Date: 17.NOV.2015 18:05:15

Low Voltage

CH13 Frequency Band 3 (2387 MHz \cong f < 2400 MHz)

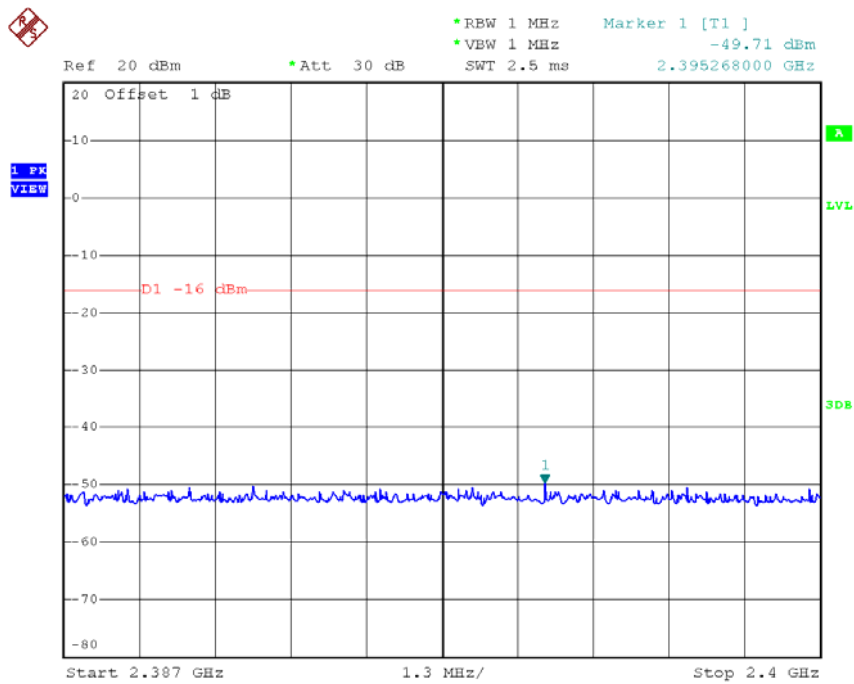

Date: 17.NOV.2015 18:05:26

Low Voltage

CH13 Frequency Band 4 (2483.5 MHz \cong f < 2496.5 MHz)

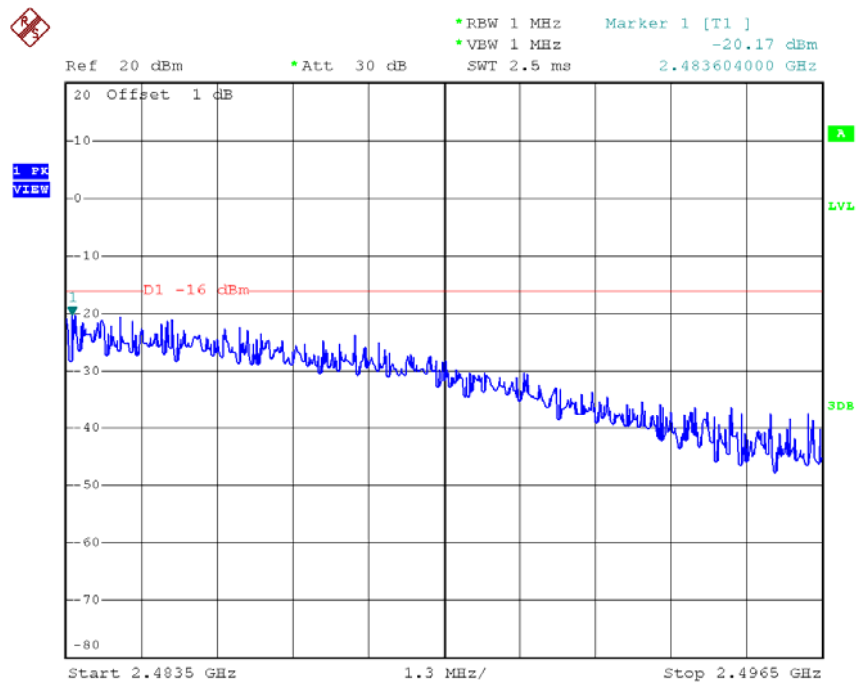

Date: 17.NOV.2015 18:05:36

Low Voltage

CH13 Frequency Band 5 (2496.5 MHz \cong f < 12.5 GHz)

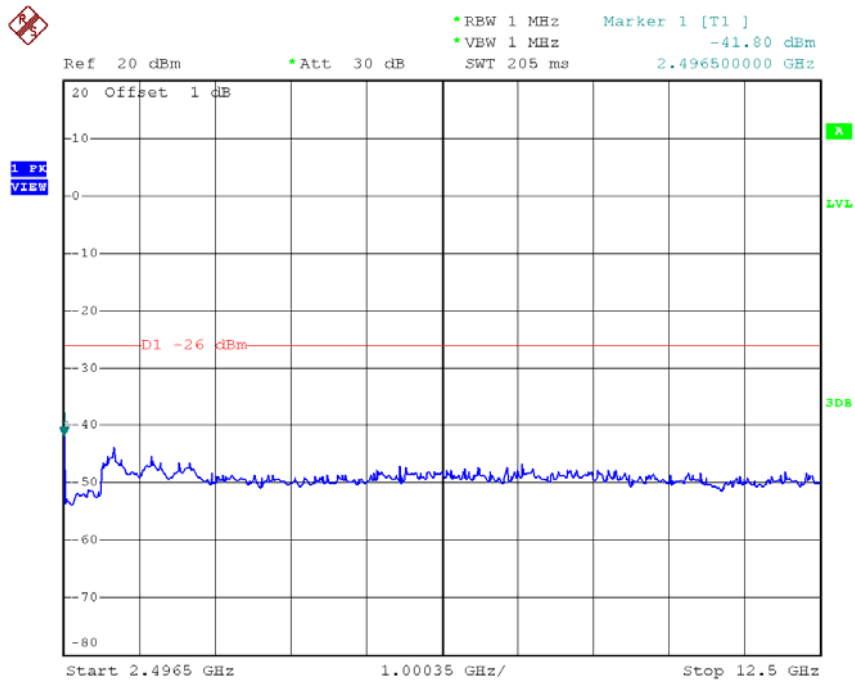

Date: 17.NOV.2015 18:05:47

For Dipole antenna

Test Mode:	802.11b/CH01,CH07,CH13
------------	------------------------

Test Voltage		V	Normal Voltage			Remarks
Test Frequency		MHz	2412	2442	2472	Low/Mid/High of test frequency range
Unwanted Emission Intensity (Power emission within 1MHz bandwidth) (units: μ W)	※ 1	μ W/MHz	0.08072	0.07295	0.10471	Limit \cong 2.5 μ W/MHz (-26 dBm/MHz)
	※ 2	μ W/MHz	0.16406	0.02679	0.01656	Limit \cong 2.5 μ W/MHz (-26 dBm/MHz)
	※ 3	μ W/MHz	12.18990	0.05129	0.02951	Limit \cong 25 μ W/MHz (-16 dBm/MHz)
	※ 4	μ W/MHz	0.01656	0.03281	11.45513	Limit \cong 25 μ W/MHz (-16 dBm/MHz)
	※ 5	μ W/MHz	0.02673	0.03556	0.04955	Limit \cong 2.5 μ W/MHz (-26 dBm/MHz)

Test Voltage		V	High Voltage			Remarks
Test Frequency		MHz	2412	2442	2472	Low/Mid/High of test frequency range
Unwanted Emission Intensity (Power emission within 1MHz bandwidth) (units: μ W)	※ 1	μ W/MHz	0.08453	0.07228	0.09840	Limit \cong 2.5 μ W/MHz (-26 dBm/MHz)
	※ 2	μ W/MHz	0.17701	0.02938	0.01663	Limit \cong 2.5 μ W/MHz (-26 dBm/MHz)
	※ 3	μ W/MHz	13.58313	0.05902	0.02825	Limit \cong 25 μ W/MHz (-16 dBm/MHz)
	※ 4	μ W/MHz	0.02065	0.02535	10.88930	Limit \cong 25 μ W/MHz (-16 dBm/MHz)
	※ 5	μ W/MHz	0.03483	0.03243	0.07870	Limit \cong 2.5 μ W/MHz (-26 dBm/MHz)

Test Voltage		V	Low Voltage			Remarks
Test Frequency		MHz	2412	2442	2472	Low/Mid/High of test frequency range
Unwanted Emission Intensity (Power emission within 1MHz bandwidth) (units: μ W)	※ 1	μ W/MHz	0.08690	0.08110	0.10280	Limit \cong 2.5 μ W/MHz (-26 dBm/MHz)
	※ 2	μ W/MHz	0.15959	0.02254	0.01774	Limit \cong 2.5 μ W/MHz (-26 dBm/MHz)
	※ 3	μ W/MHz	13.74042	0.05093	0.02793	Limit \cong 25 μ W/MHz (-16 dBm/MHz)
	※ 4	μ W/MHz	0.02138	0.03170	10.66596	Limit \cong 25 μ W/MHz (-16 dBm/MHz)
	※ 5	μ W/MHz	0.02924	0.02992	0.04966	Limit \cong 2.5 μ W/MHz (-26 dBm/MHz)

Normal Voltage

CH01 Frequency Band 1 (30 MHz \leq f \leq 1000 MHz)

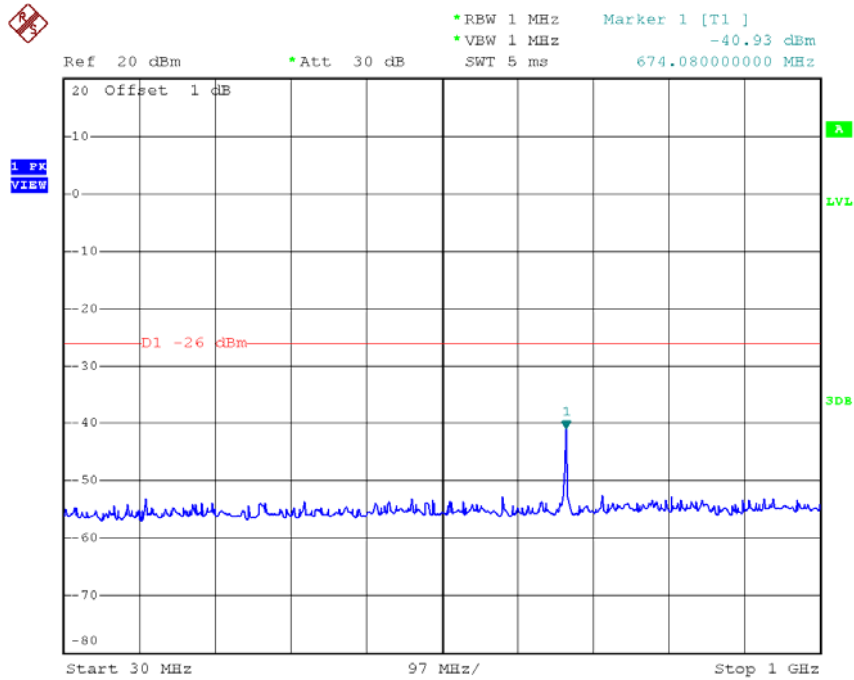

Date: 12.NOV.2015 16:20:58

Normal Voltage

CH01 Frequency Band 2 (1000 MHz < f \leq 2387 MHz)

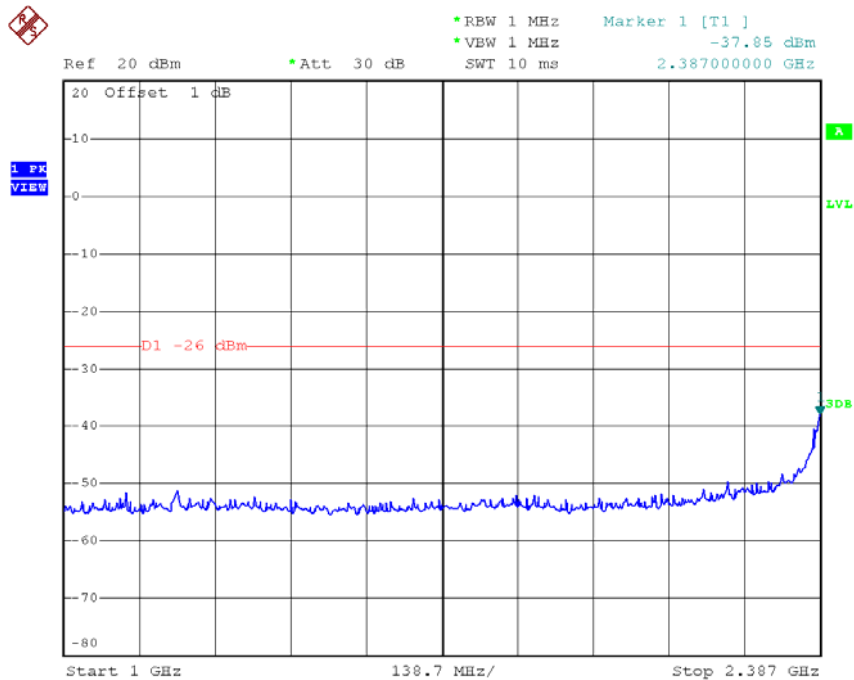

Date: 12.NOV.2015 16:21:08

Normal Voltage
CH01 Frequency Band 3 (2387 MHz \cong f < 2400 MHz)

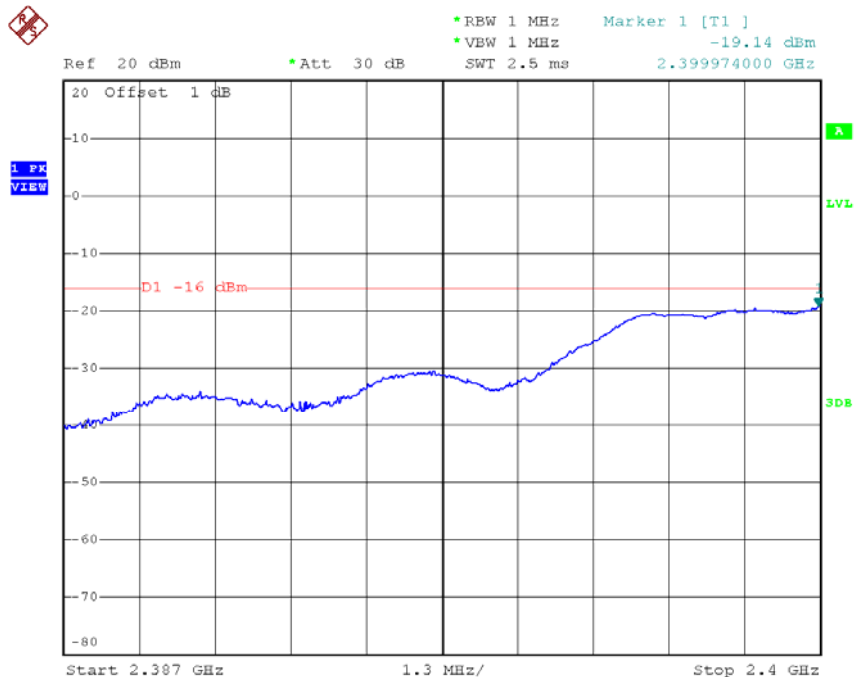

Date: 12.NOV.2015 16:21:18

Normal Voltage
CH01 Frequency Band 4 (2483.5 MHz \cong f < 2496.5 MHz)

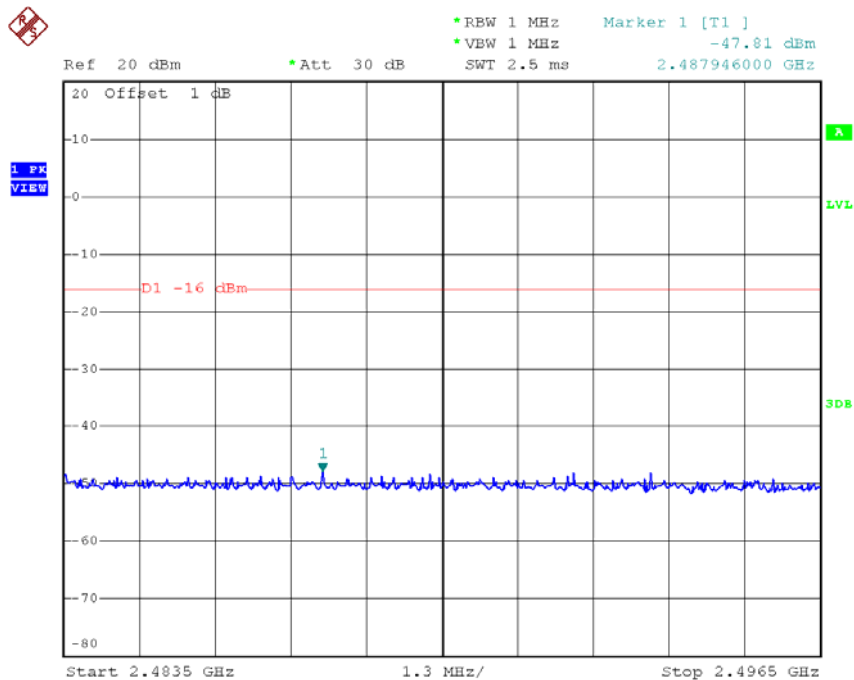

Date: 12.NOV.2015 16:21:27

Normal Voltage
CH01 Frequency Band 5 (2496.5 MHz \leq f < 12.5 GHz)

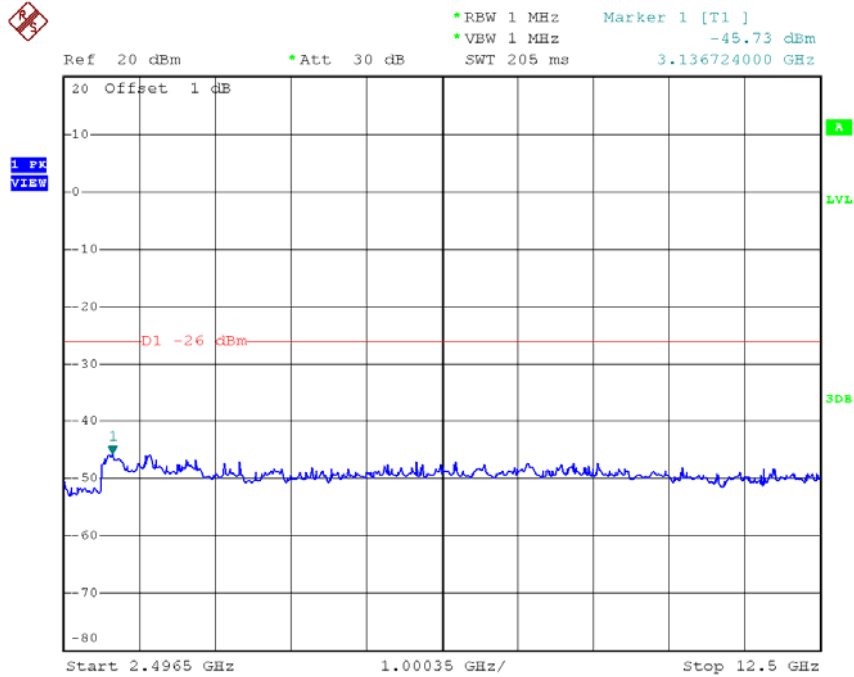

Date: 12.NOV.2015 16:21:37

Normal Voltage
CH07 Frequency Band 1 (30 MHz \leq f \leq 1000 MHz)

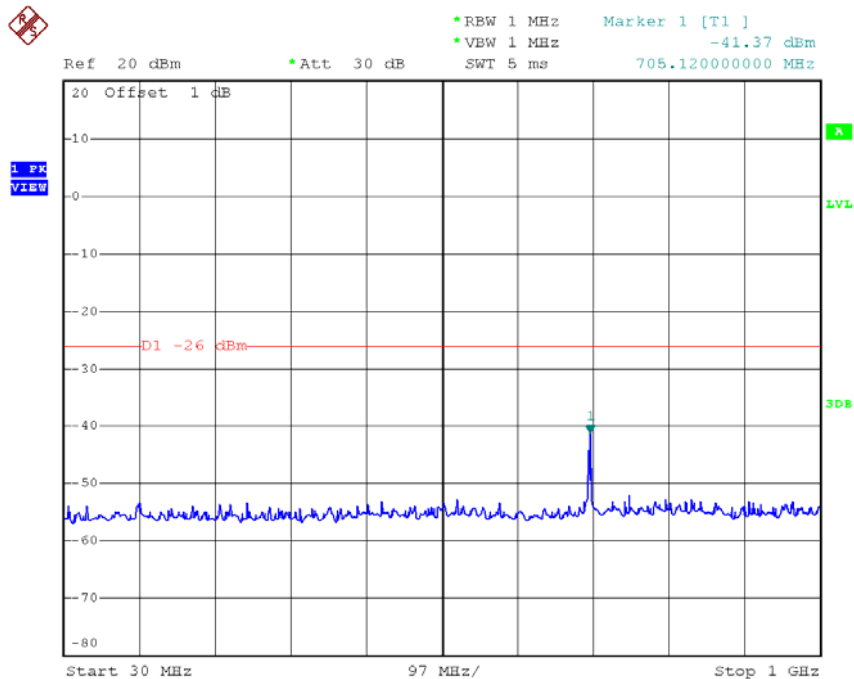

Date: 12.NOV.2015 16:35:54

Normal Voltage
CH07 Frequency Band 2 (1000 MHz $f \leq 2387 \text{ MHz}$)

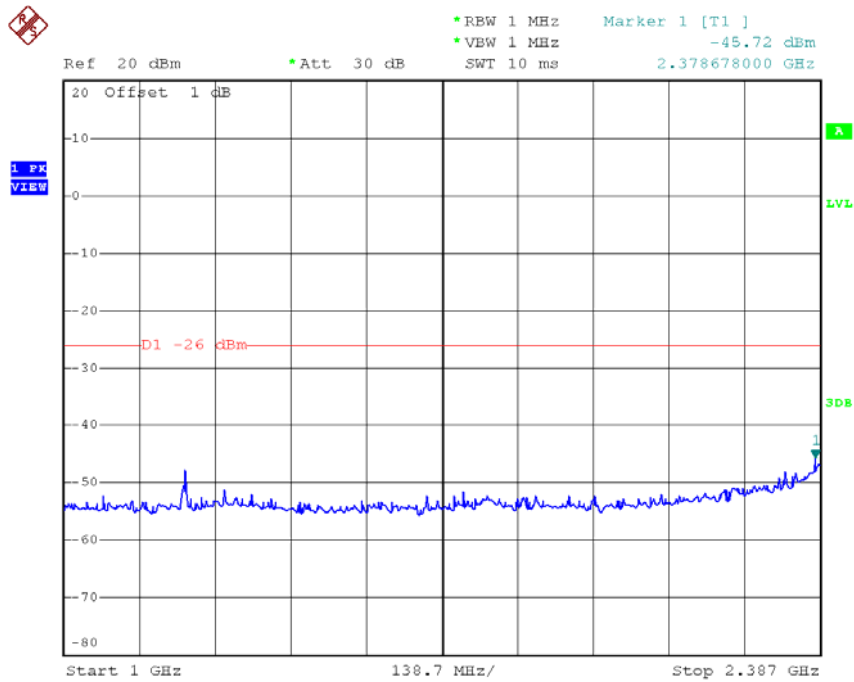

Date: 12.NOV.2015 16:36:04

Normal Voltage
CH07 Frequency Band 3 (2387 MHz $\leq f < 2400 \text{ MHz}$)

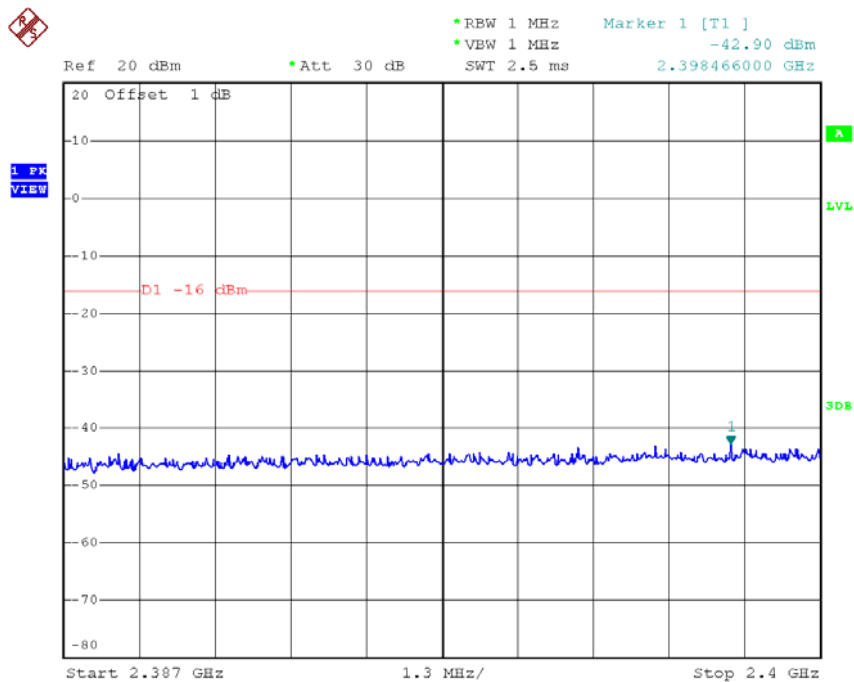

Date: 12.NOV.2015 16:36:14

Normal Voltage

CH07 Frequency Band 4 (2483.5 MHz \cong f < 2496.5 MHz)

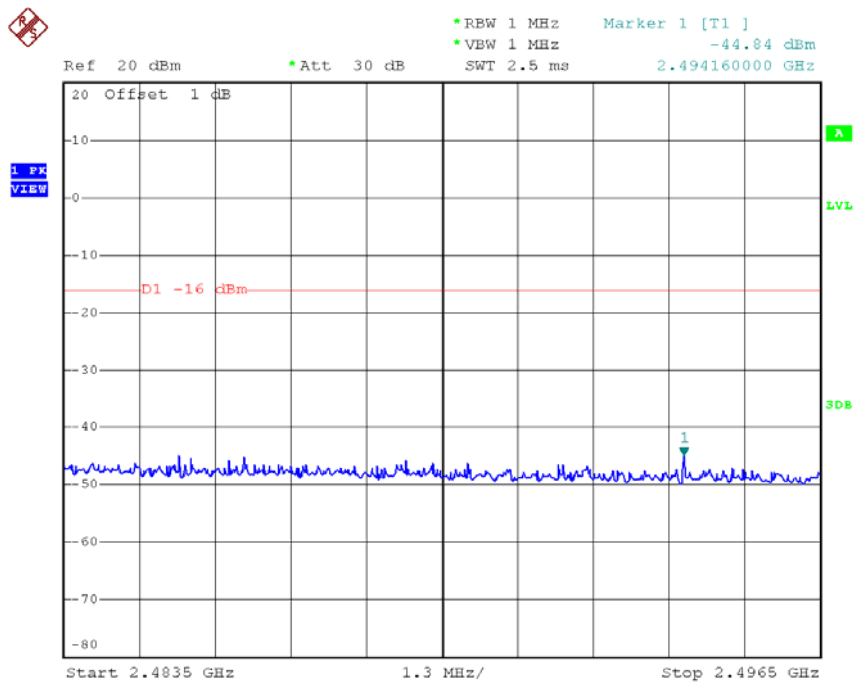

Date: 12.NOV.2015 16:36:23

Normal Voltage

CH07 Frequency Band 5 (2496.5 MHz \cong f < 12.5 GHz)

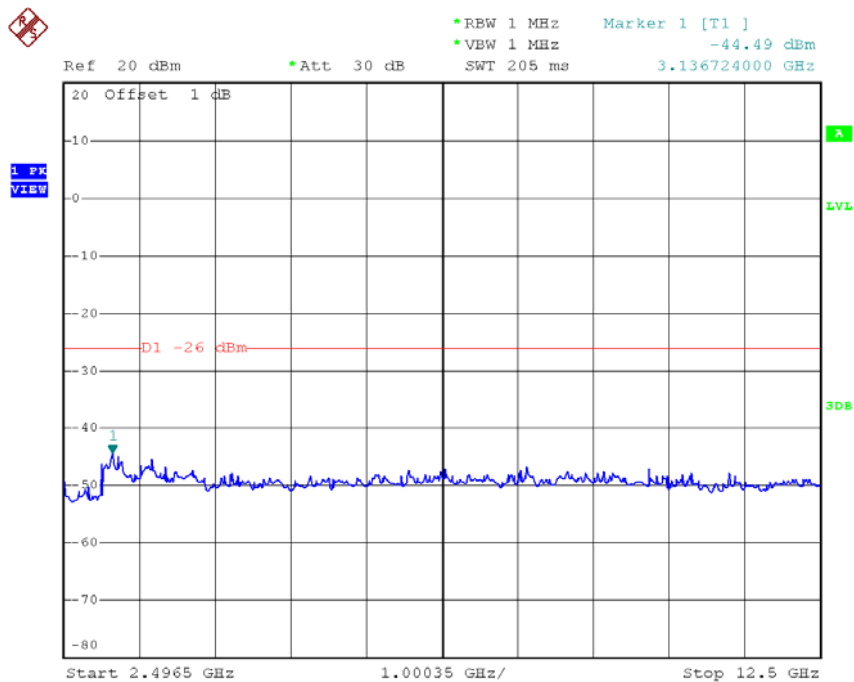

Date: 12.NOV.2015 16:36:34

Normal Voltage

CH13 Frequency Band 3 (2387 MHz \cong f < 2400 MHz)

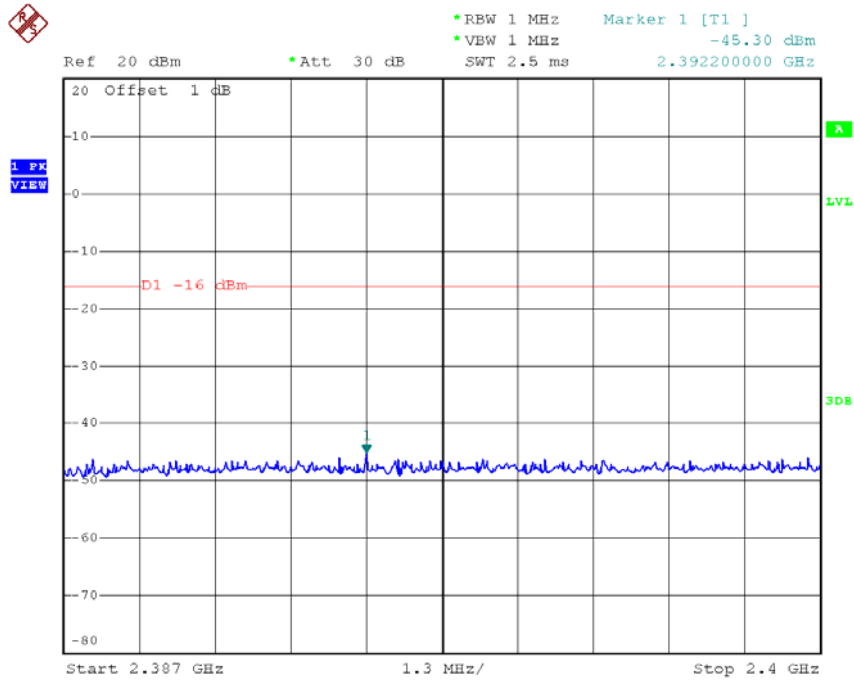

Date: 12.NOV.2015 16:44:37

Normal Voltage

CH13 Frequency Band 4 (2483.5 MHz \cong f < 2496.5 MHz)

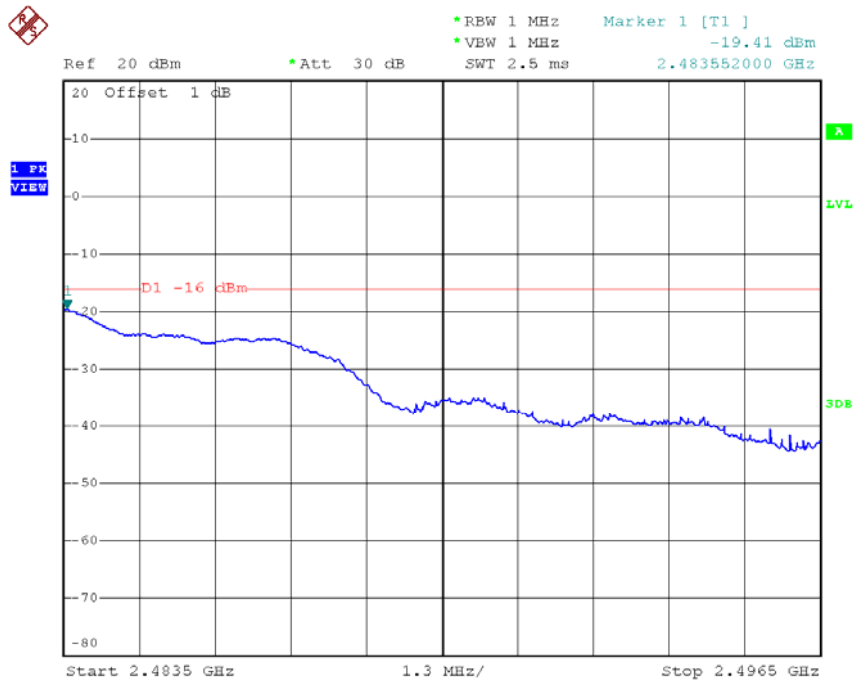

Date: 12.NOV.2015 16:44:46

Normal Voltage CH13 Frequency Band 5 (2496.5 MHz \cong f <12.5 GHz)

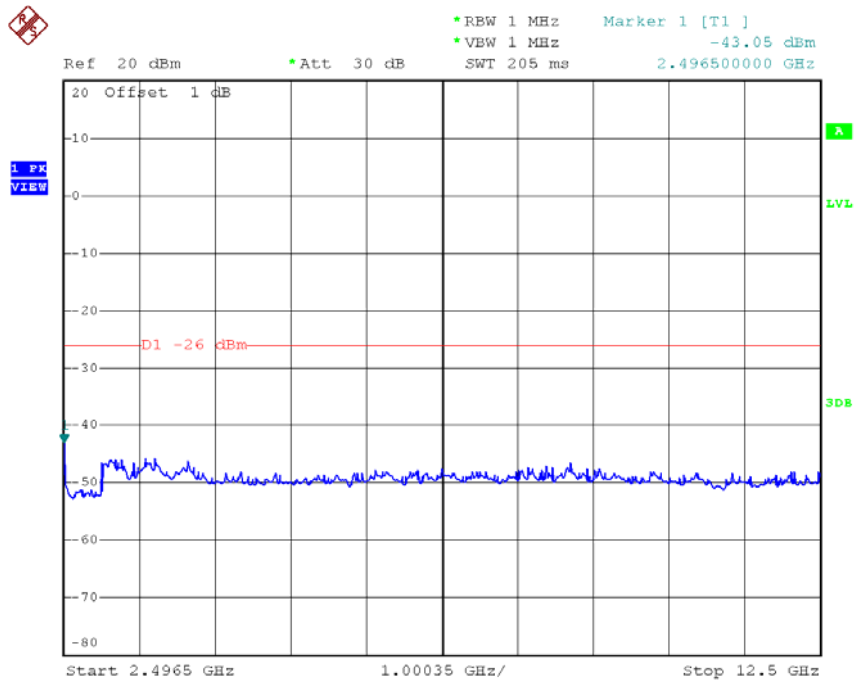

Date: 12.NOV.2015 16:44:56

High Voltage CH01 Frequency Band 3 (2387 MHz \cong f < 2400 MHz)

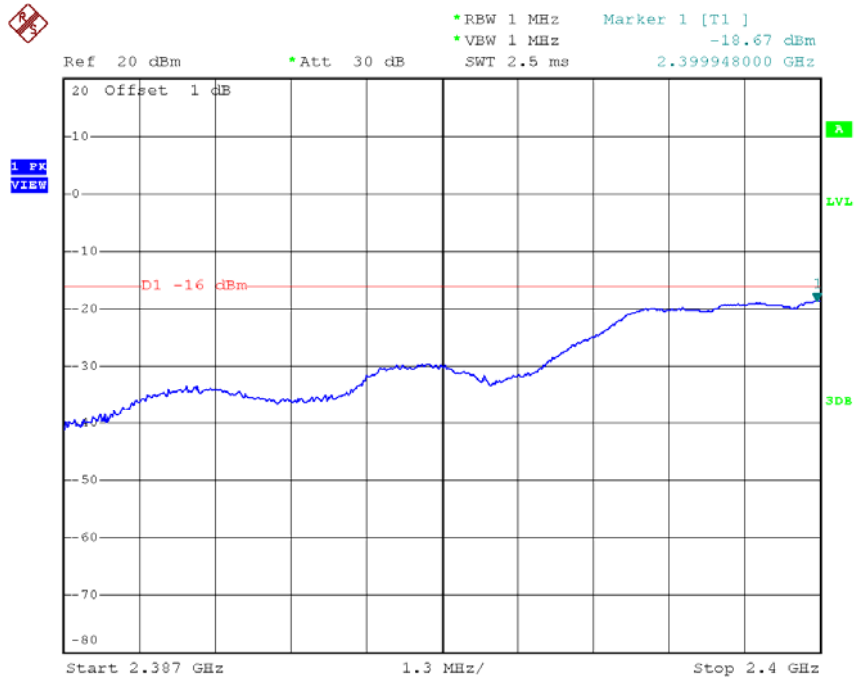

Date: 12.NOV.2015 16:22:29

High Voltage CH01 Frequency Band 4 (2483.5 MHz \cong f < 2496.5 MHz)

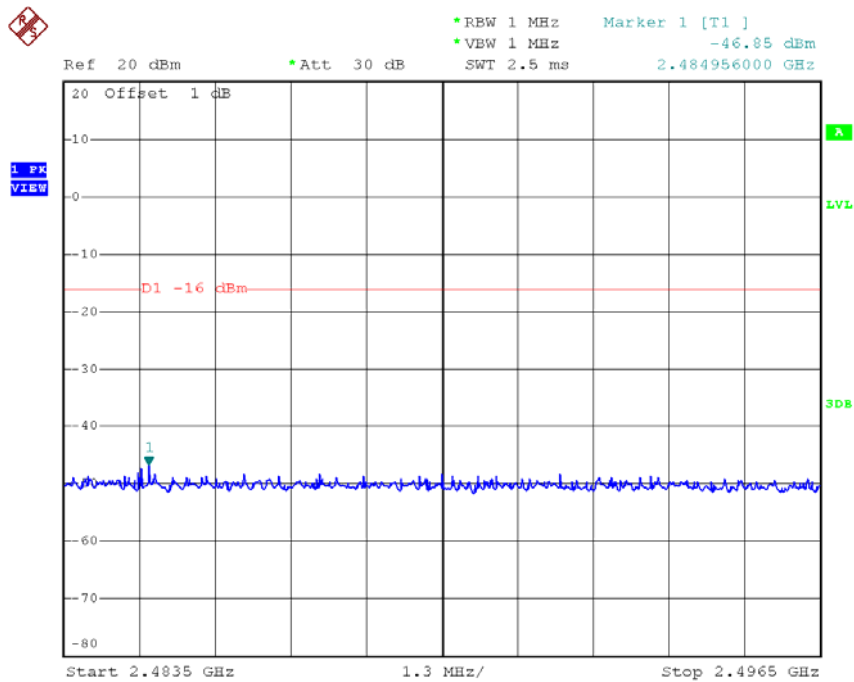

Date: 12.NOV.2015 16:22:38

High Voltage CH01 Frequency Band 5 (2496.5 MHz \leq f < 12.5 GHz)

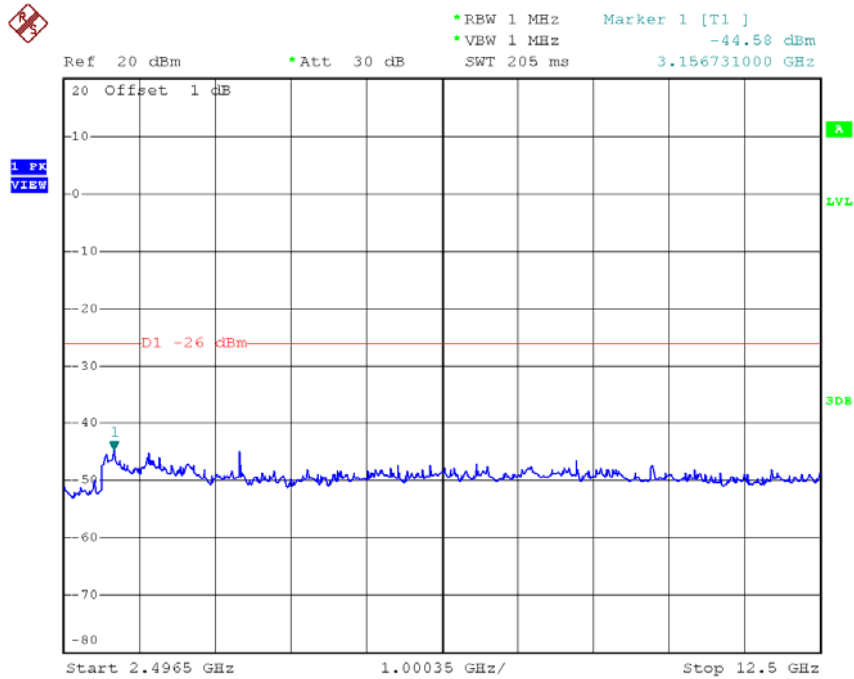

Date: 12.NOV.2015 16:22:49

High Voltage CH07 Frequency Band 1 (30 MHz \leq f \leq 1000 MHz)

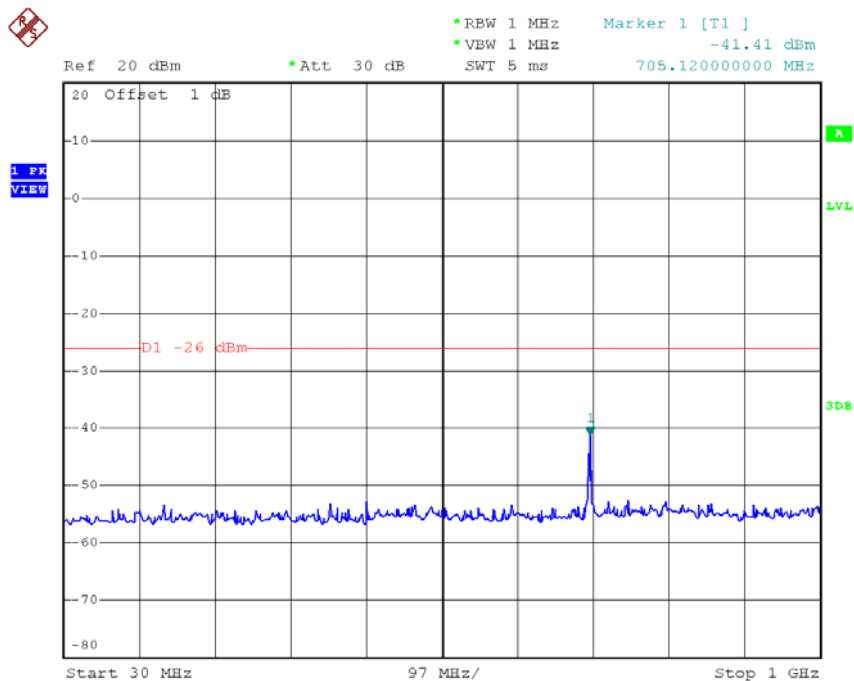

Date: 12.NOV.2015 16:33:34

High Voltage

CH07 Frequency Band 2 (1000 MHz $f \leq 2387 \text{ MHz}$)

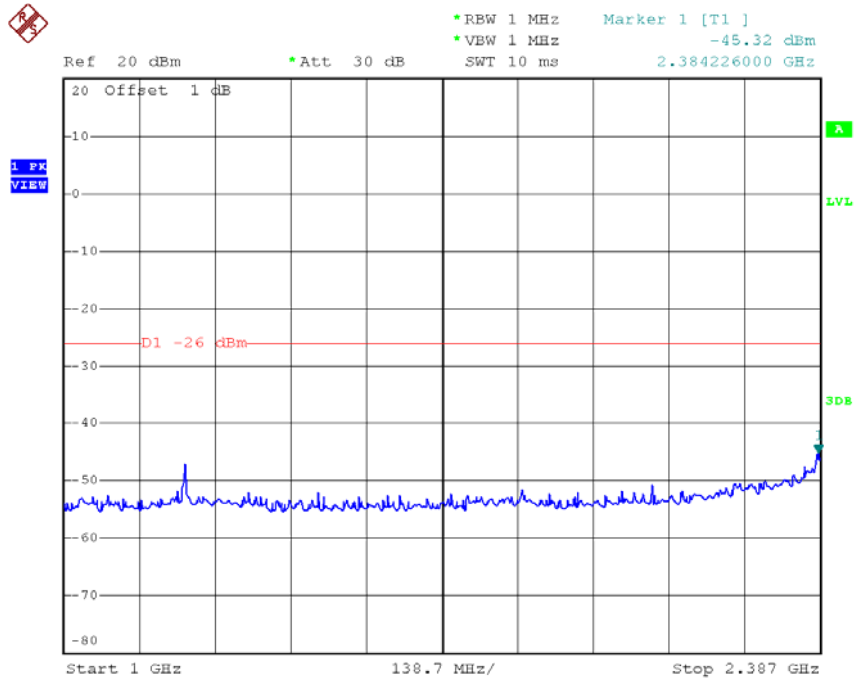

Date: 12.NOV.2015 16:33:44

High Voltage

CH07 Frequency Band 3 (2387 MHz $\leq f < 2400 \text{ MHz}$)

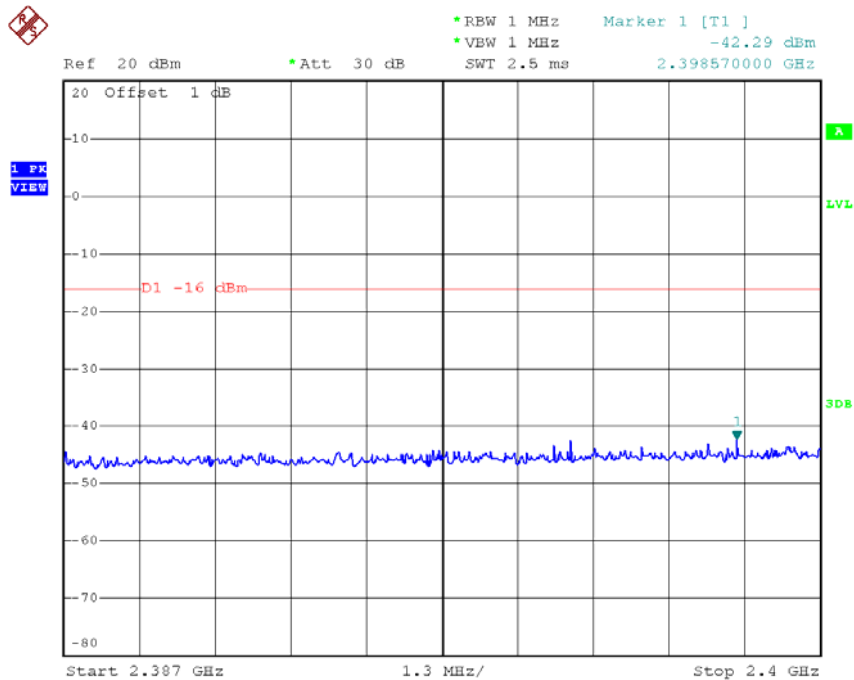

Date: 12.NOV.2015 16:33:54

High Voltage

CH07 Frequency Band 4 ($2483.5\text{ MHz} \leq f < 2496.5\text{ MHz}$)

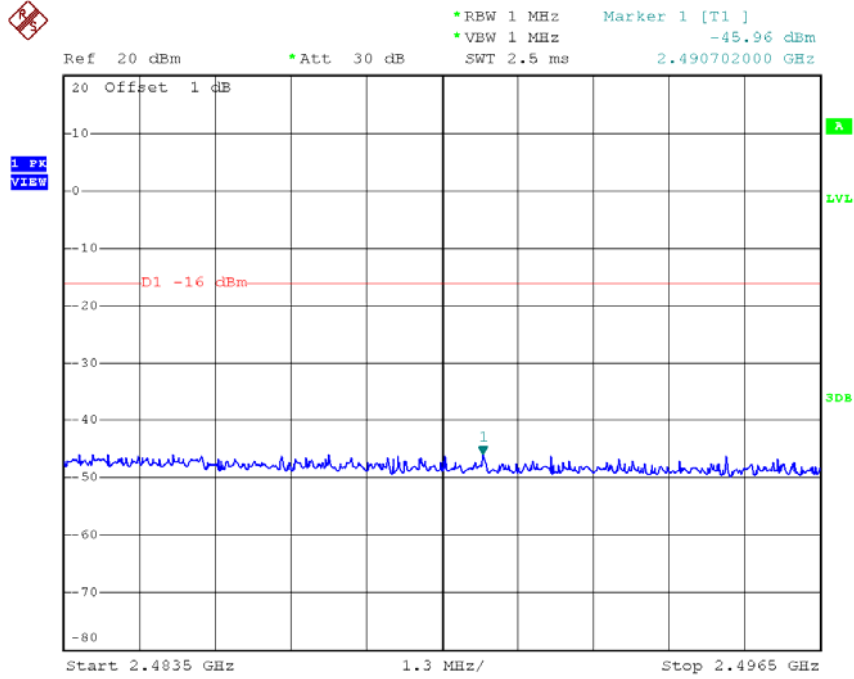

Date: 12.NOV.2015 16:34:03

High Voltage

CH07 Frequency Band 5 ($2496.5\text{ MHz} \leq f < 12.5\text{ GHz}$)

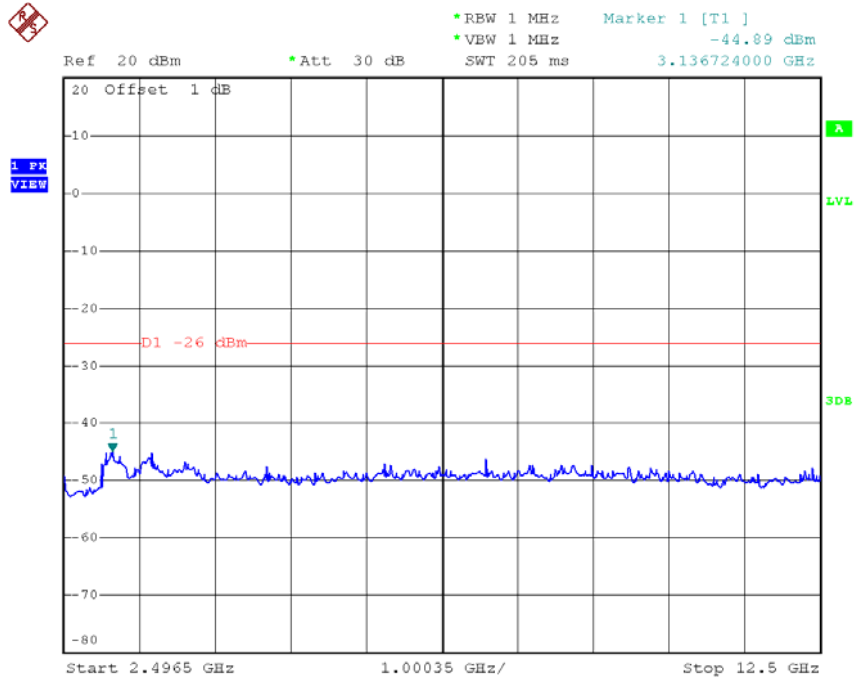

Date: 12.NOV.2015 16:34:13

High Voltage

CH13 Frequency Band 1 (30 MHz \leq f \leq 1000 MHz)

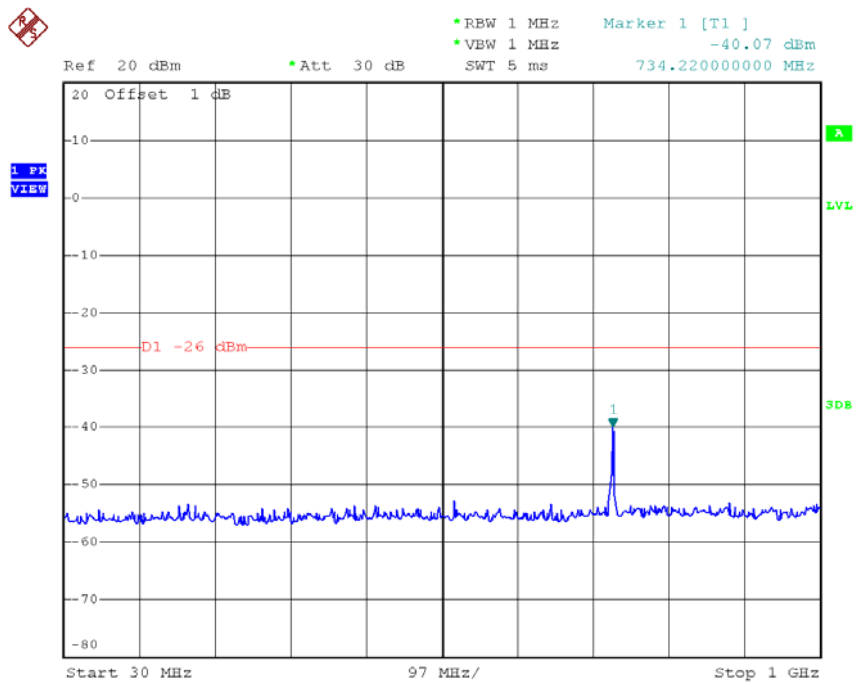

Date: 12.NOV.2015 16:41:58

High Voltage

CH13 Frequency Band 2 (1000 MHz < f \leq 2387 MHz)

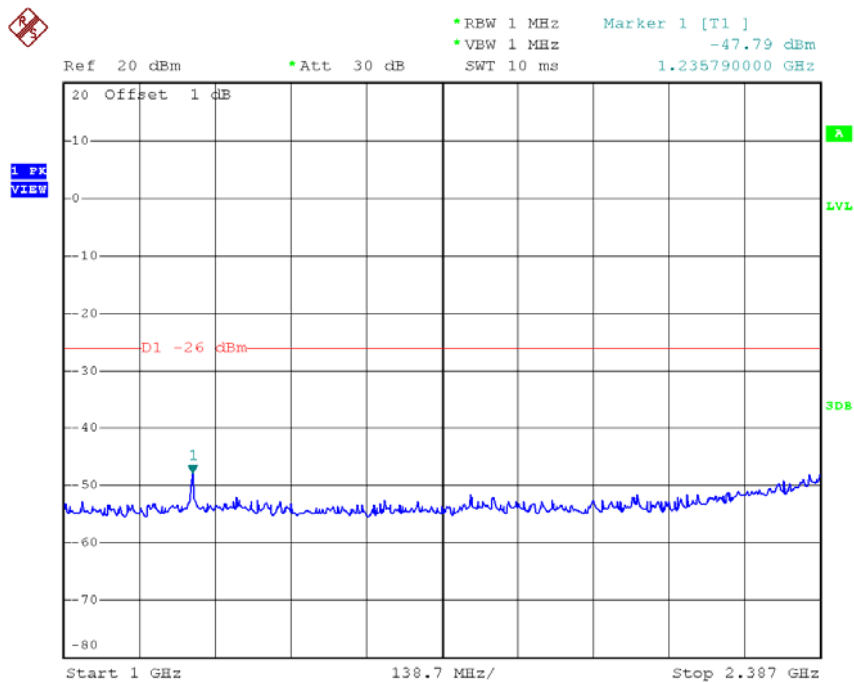

Date: 12.NOV.2015 16:42:08

High Voltage

CH13 Frequency Band 3 (2387 MHz \cong f < 2400 MHz)

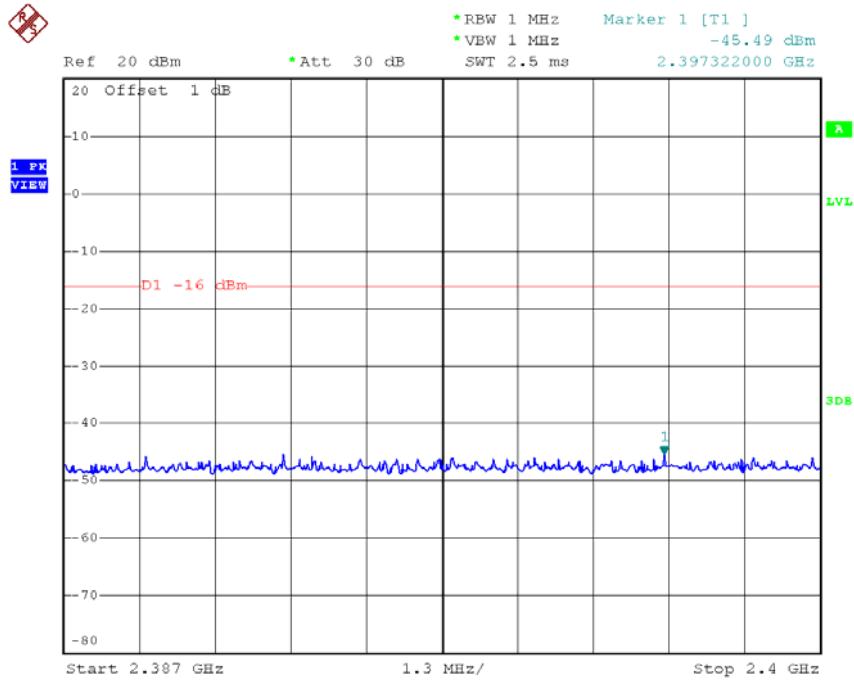

Date: 12.NOV.2015 16:42:18

High Voltage

CH13 Frequency Band 4 (2483.5 MHz \cong f < 2496.5 MHz)

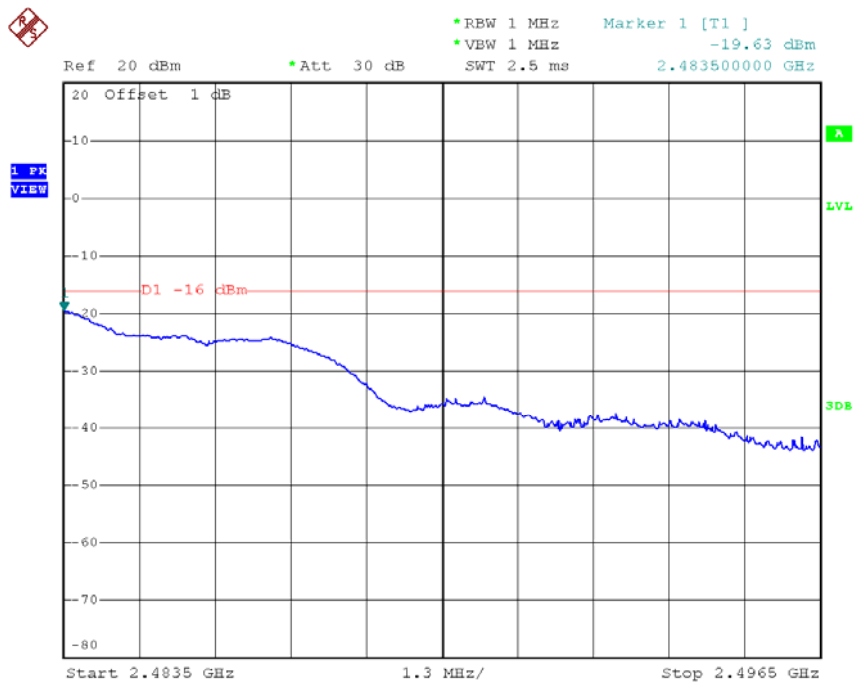

Date: 12.NOV.2015 16:42:27

High Voltage

CH13 Frequency Band 5 (2496.5 MHz \cong f < 12.5 GHz)

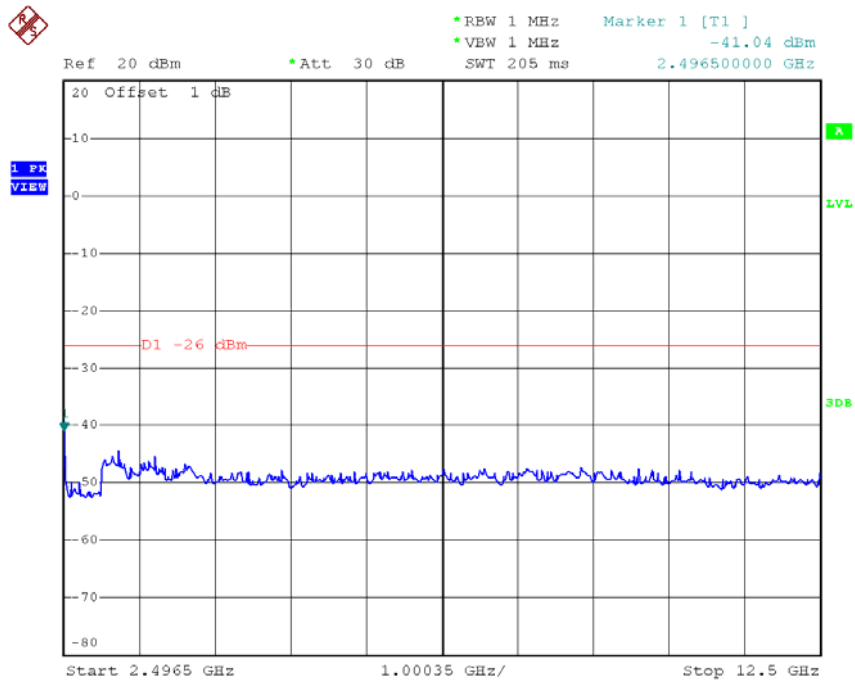

Date: 12.NOV.2015 16:42:38

Low Voltage

CH01 Frequency Band 1 (30 MHz \leq f \leq 1000 MHz)

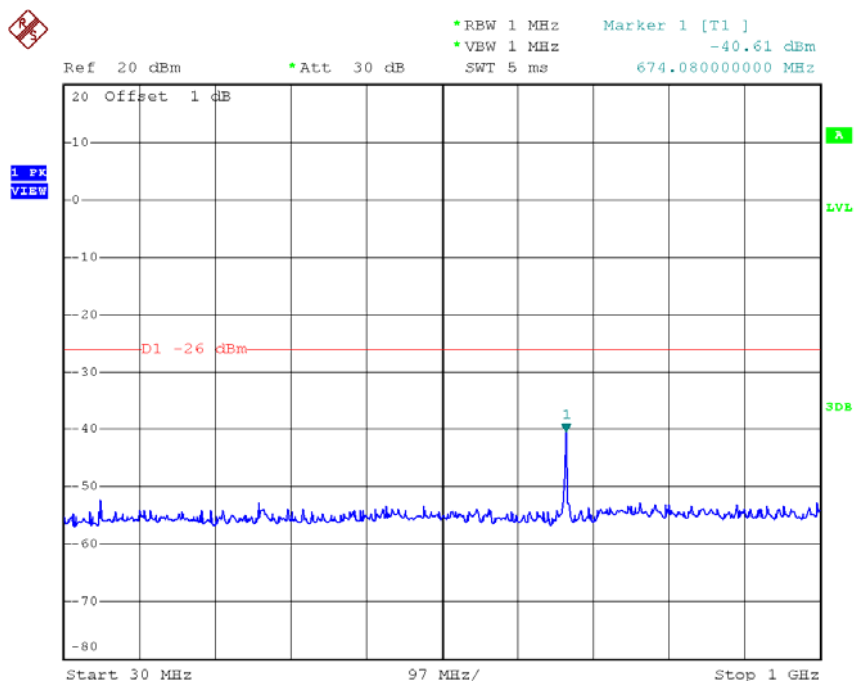

Date: 12.NOV.2015 16:23:02

Low Voltage

CH01 Frequency Band 2 (1000 MHz < f \leq 2387 MHz)

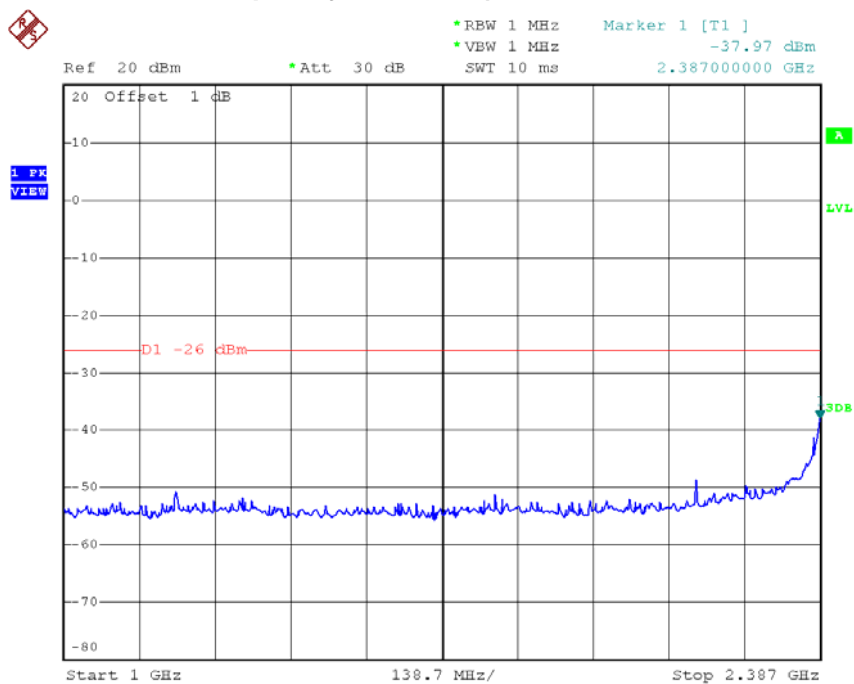

Date: 12.NOV.2015 16:23:13

Low Voltage CH01 Frequency Band 3 (2387 MHz \cong f < 2400 MHz)

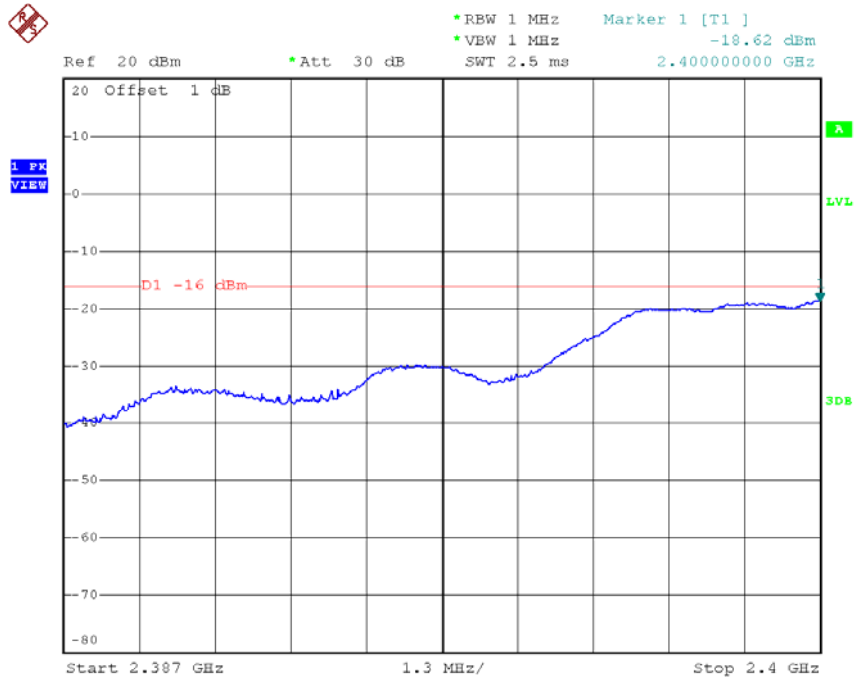

Date: 12.NOV.2015 16:23:23

Low Voltage CH01 Frequency Band 4 (2483.5 MHz \cong f < 2496.5 MHz)

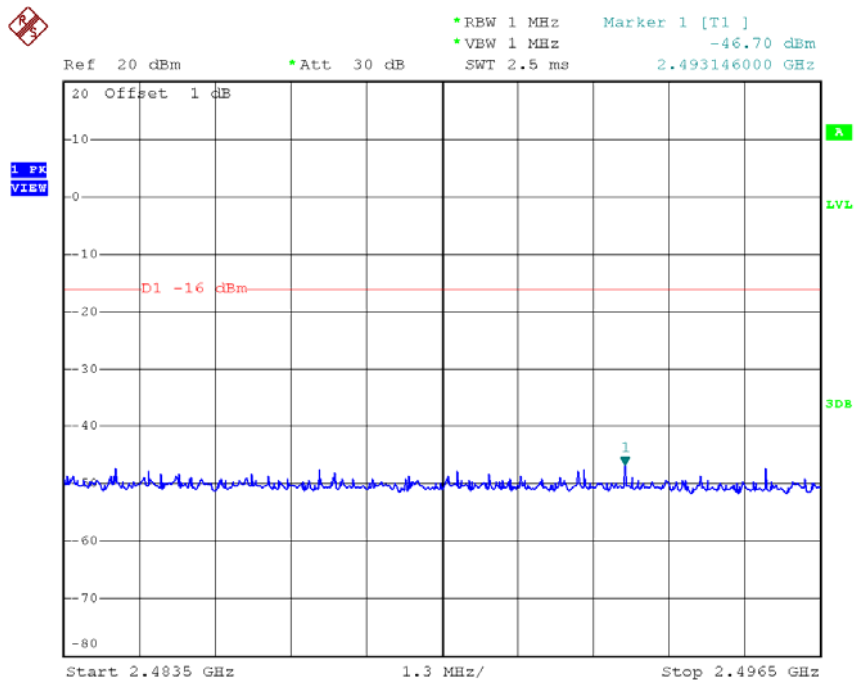

Date: 12.NOV.2015 16:23:32

Low Voltage

CH01 Frequency Band 5 (2496.5 MHz \leq f < 12.5 GHz)

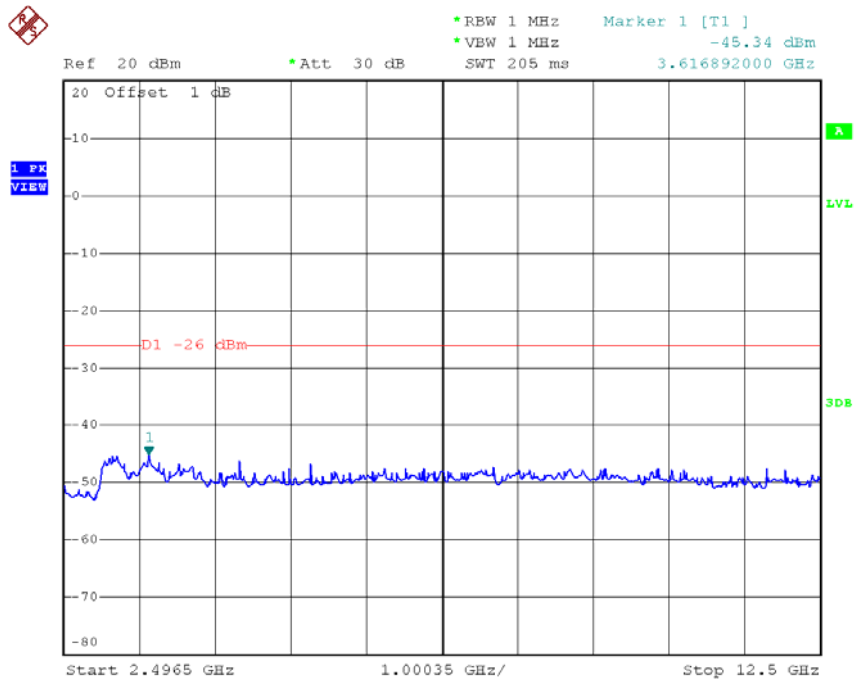

Date: 12.NOV.2015 16:23:42

Low Voltage

CH07 Frequency Band 1 (30 MHz \leq f \leq 1000 MHz)

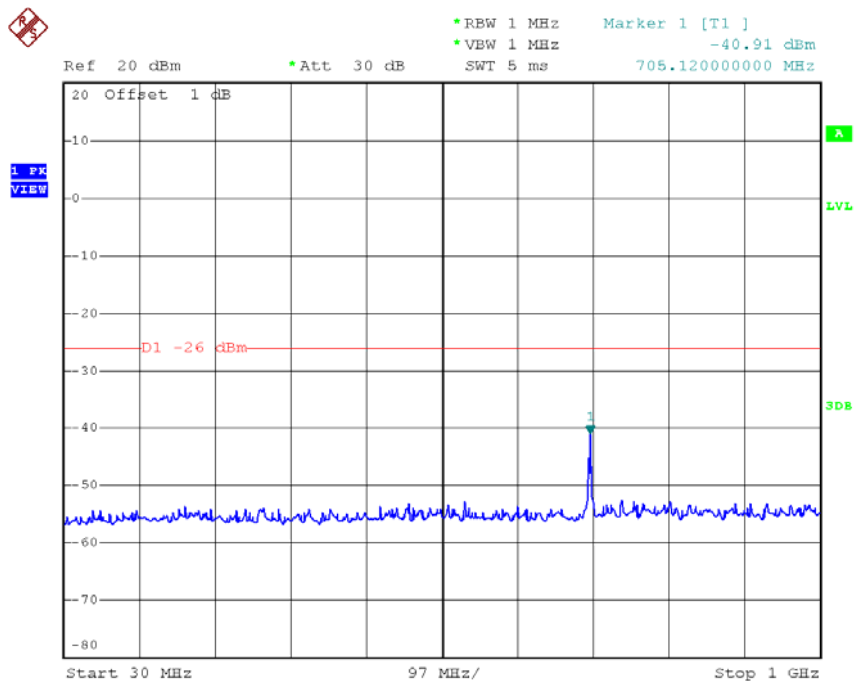

Date: 12.NOV.2015 16:38:15

Low Voltage

CH07 Frequency Band 2 (1000 MHz < f ≤ 2387 MHz)

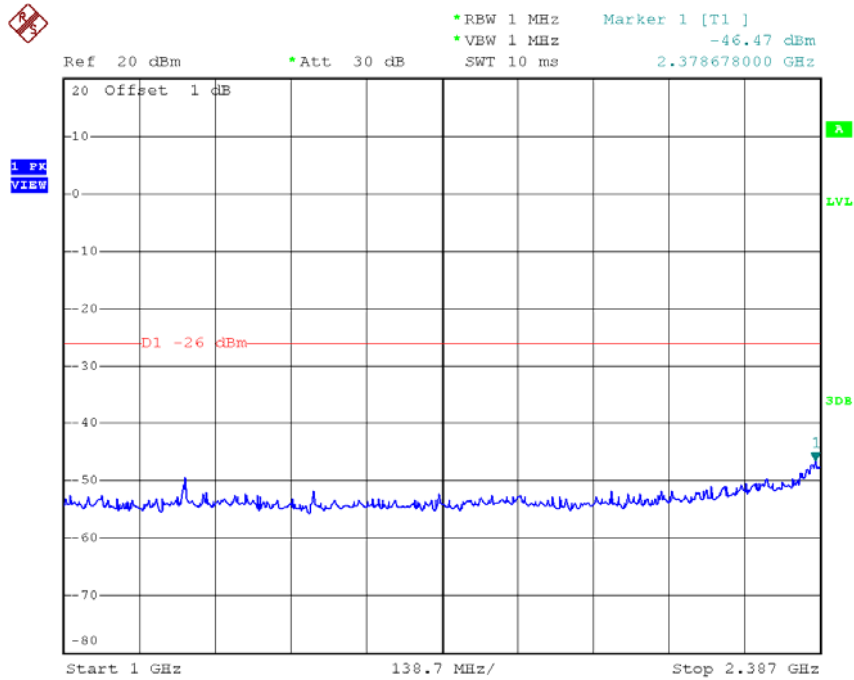

Date: 12.NOV.2015 16:38:25

Low Voltage

CH07 Frequency Band 3 (2387 MHz ≤ f < 2400 MHz)

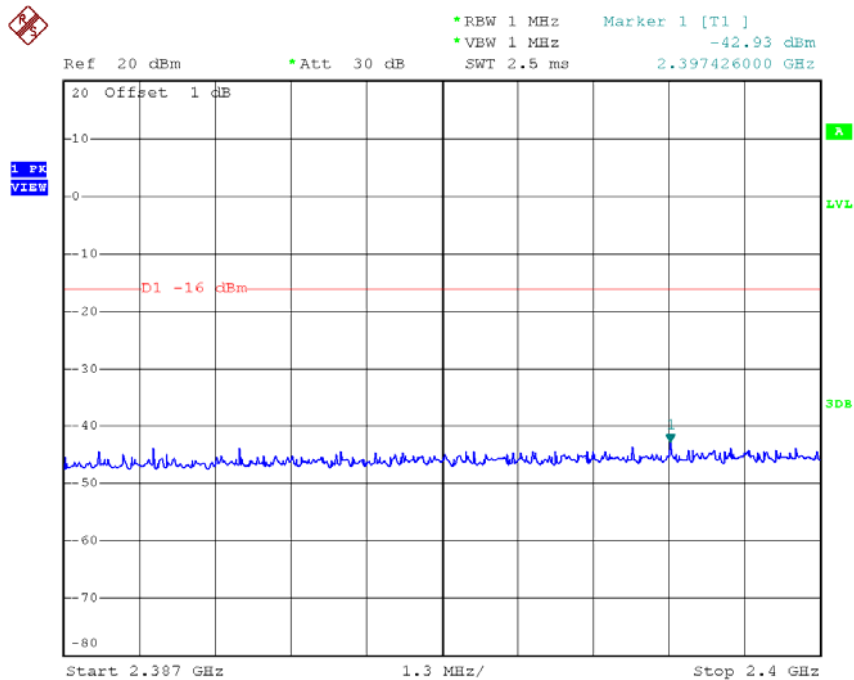

Date: 12.NOV.2015 16:38:35

Low Voltage

CH07 Frequency Band 4 ($2483.5 \text{ MHz} \leq f < 2496.5 \text{ MHz}$)

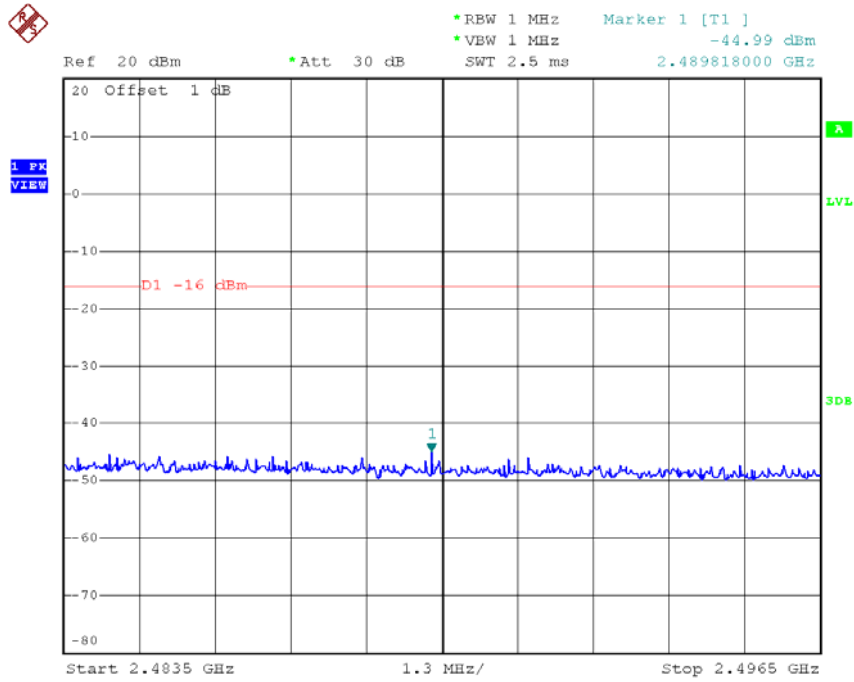

Date: 12.NOV.2015 16:38:44

Low Voltage

CH07 Frequency Band 5 ($2496.5 \text{ MHz} \leq f < 12.5 \text{ GHz}$)

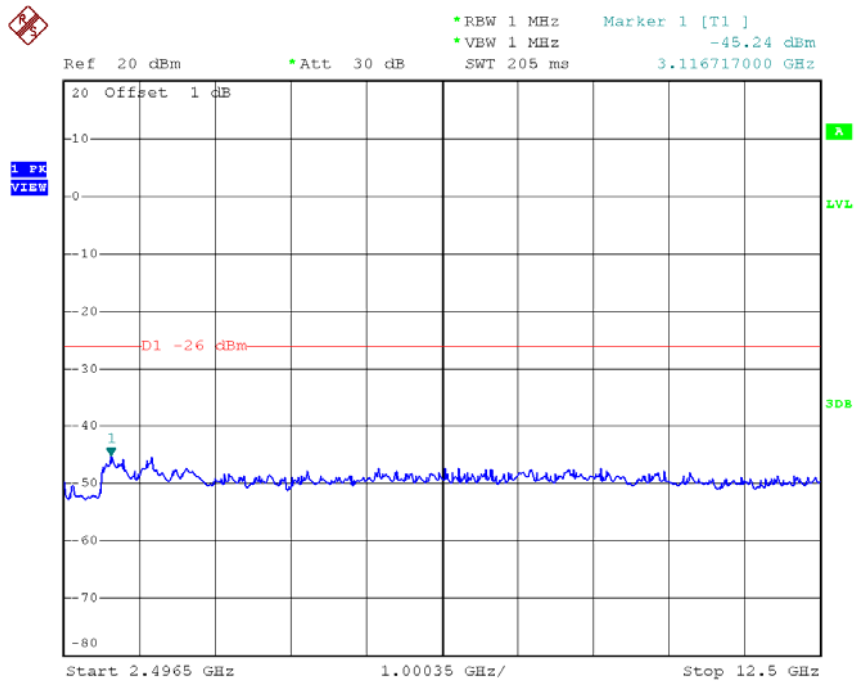

Date: 12.NOV.2015 16:38:55

Low Voltage

CH13 Frequency Band 1 (30 MHz \leq f \leq 1000 MHz)

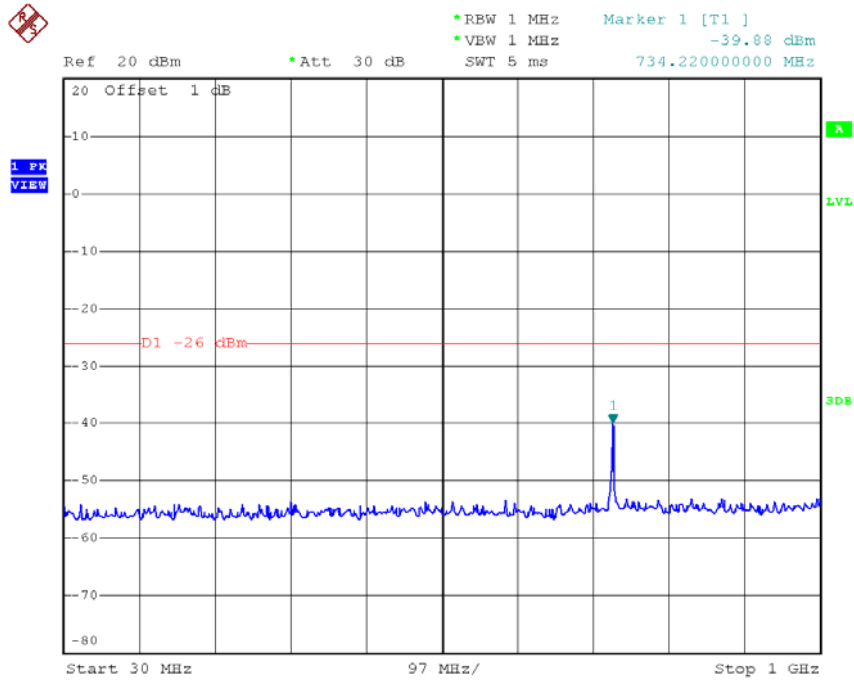

Date: 12.NOV.2015 16:46:37

Low Voltage

CH13 Frequency Band 2 (1000 MHz < f \leq 2387 MHz)

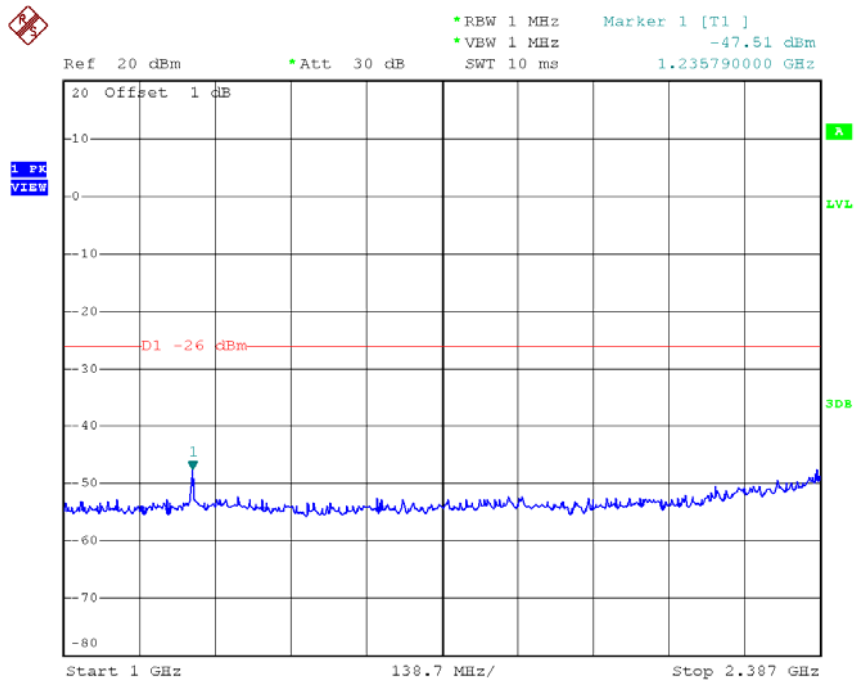

Date: 12.NOV.2015 16:46:48

Low Voltage
CH13 Frequency Band 3 (2387 MHz \cong f < 2400 MHz)

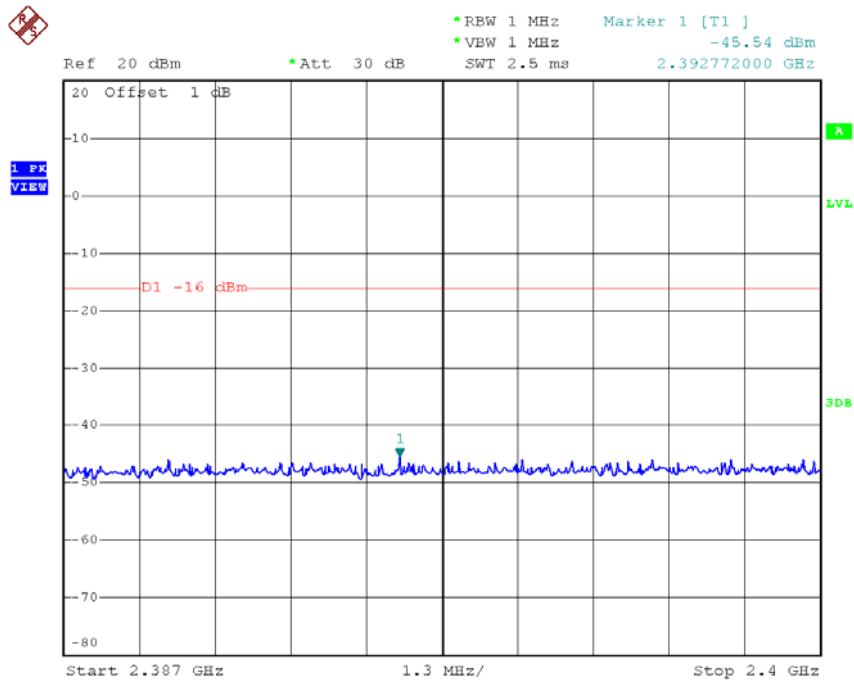

Date: 12.NOV.2015 16:46:58

Low Voltage
CH13 Frequency Band 4 (2483.5 MHz \cong f < 2496.5 MHz)

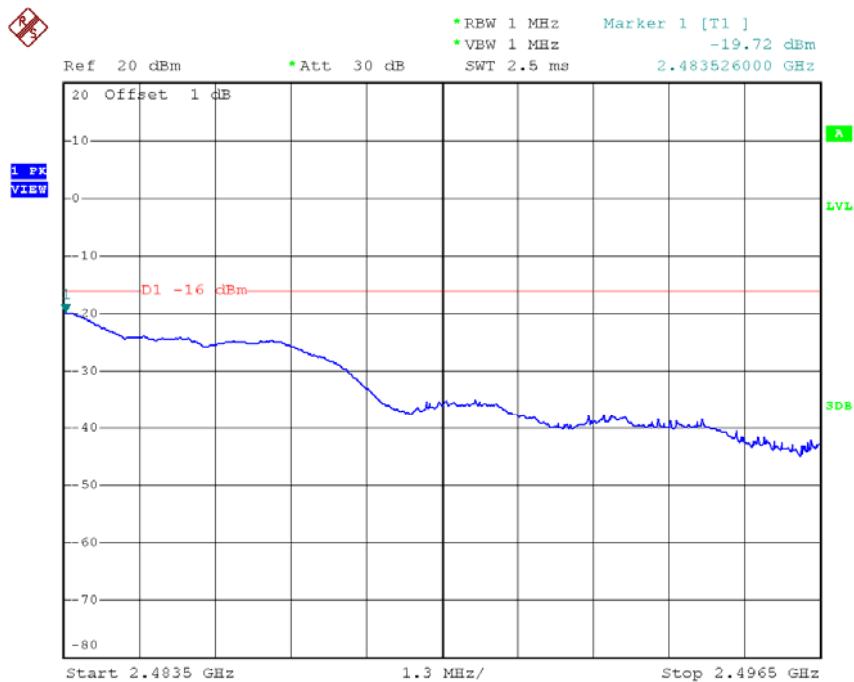

Date: 12.NOV.2015 16:47:07

Low Voltage

CH13 Frequency Band 5 (2496.5 MHz \cong f <12.5 GHz)

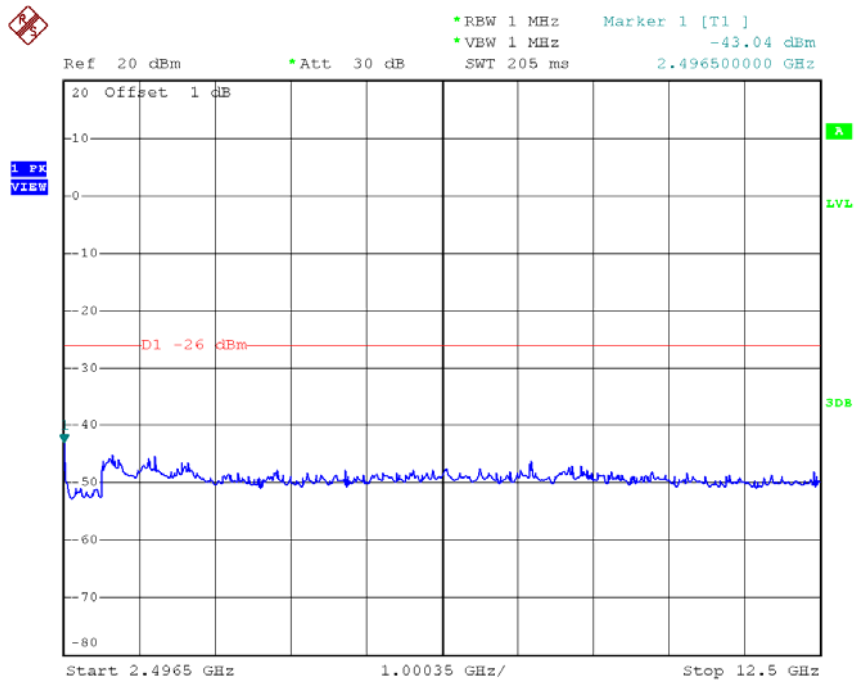

Date: 12.NOV.2015 16:47:17

Test Mode:	802.11g/CH01,CH07,CH13
------------	------------------------

Test Voltage		V	Normal Voltage			Remarks
Test Frequency		MHz	2412	2442	2472	Low/Mid/High of test frequency range
Unwanted Emission Intensity (Power emission within 1MHz bandwidth) (units: μ W)	※ 1	μ W/MHz	0.04276	0.03565	0.03258	Limit \leq 2.5 μ W/MHz (-26 dBm/MHz)
	※ 2	μ W/MHz	0.38019	0.03311	0.02075	Limit \leq 2.5 μ W/MHz (-26 dBm/MHz)
	※ 3	μ W/MHz	16.25549	0.50933	0.02636	Limit \leq 25 μ W/MHz (-16 dBm/MHz)
	※ 4	μ W/MHz	0.06871	0.82035	18.74995	Limit \leq 25 μ W/MHz (-16 dBm/MHz)
	※ 5	μ W/MHz	0.03177	0.06637	0.05224	Limit \leq 2.5 μ W/MHz (-26 dBm/MHz)

Test Voltage		V	High Voltage			Remarks
Test Frequency		MHz	2412	2442	2472	Low/Mid/High of test frequency range
Unwanted Emission Intensity (Power emission within 1MHz bandwidth) (units: μ W)	※ 1	μ W/MHz	0.03214	0.03837	0.02754	Limit \leq 2.5 μ W/MHz (-26 dBm/MHz)
	※ 2	μ W/MHz	0.41020	0.09268	0.01866	Limit \leq 2.5 μ W/MHz (-26 dBm/MHz)
	※ 3	μ W/MHz	15.88547	0.40179	0.03724	Limit \leq 25 μ W/MHz (-16 dBm/MHz)
	※ 4	μ W/MHz	0.05534	1.19124	16.82674	Limit \leq 25 μ W/MHz (-16 dBm/MHz)
	※ 5	μ W/MHz	0.03811	0.17061	0.06622	Limit \leq 2.5 μ W/MHz (-26 dBm/MHz)

Test Voltage		V	Low Voltage			Remarks
Test Frequency		MHz	2412	2442	2472	Low/Mid/High of test frequency range
Unwanted Emission Intensity (Power emission within 1MHz bandwidth) (units: μ W)	※ 1	μ W/MHz	0.05848	0.02838	0.02512	Limit \leq 2.5 μ W/MHz (-26 dBm/MHz)
	※ 2	μ W/MHz	0.37325	0.06577	0.01592	Limit \leq 2.5 μ W/MHz (-26 dBm/MHz)
	※ 3	μ W/MHz	14.12538	0.40738	0.03184	Limit \leq 25 μ W/MHz (-16 dBm/MHz)
	※ 4	μ W/MHz	0.06839	0.91201	13.93157	Limit \leq 25 μ W/MHz (-16 dBm/MHz)
	※ 5	μ W/MHz	0.02958	0.04498	0.05495	Limit \leq 2.5 μ W/MHz (-26 dBm/MHz)

Normal Voltage
CH01 Frequency Band 1 (30 MHz \leq f \leq 1000 MHz)

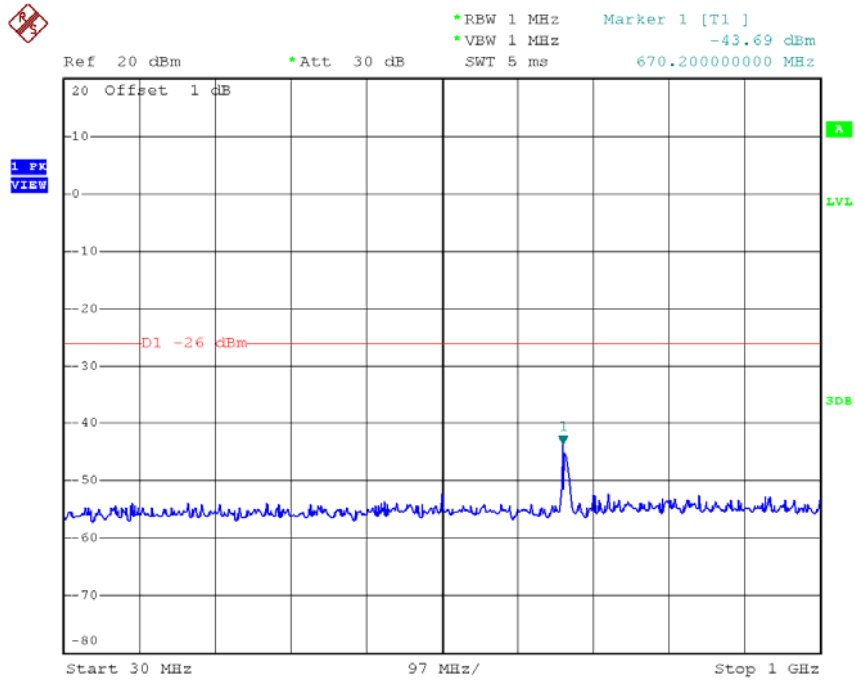

Date: 13.NOV.2015 17:57:09

Normal Voltage
CH01 Frequency Band 2 (1000 MHz < f ≤ 2387 MHz)

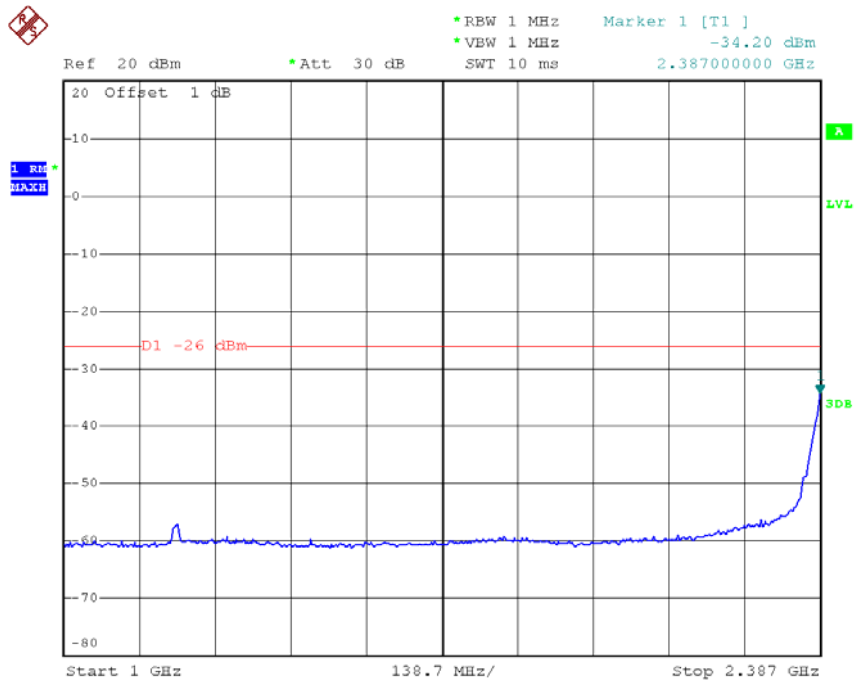

Date: 13.NOV.2015 18:09:16

Normal Voltage CH01 Frequency Band 3 (2387 MHz \cong f < 2400 MHz)

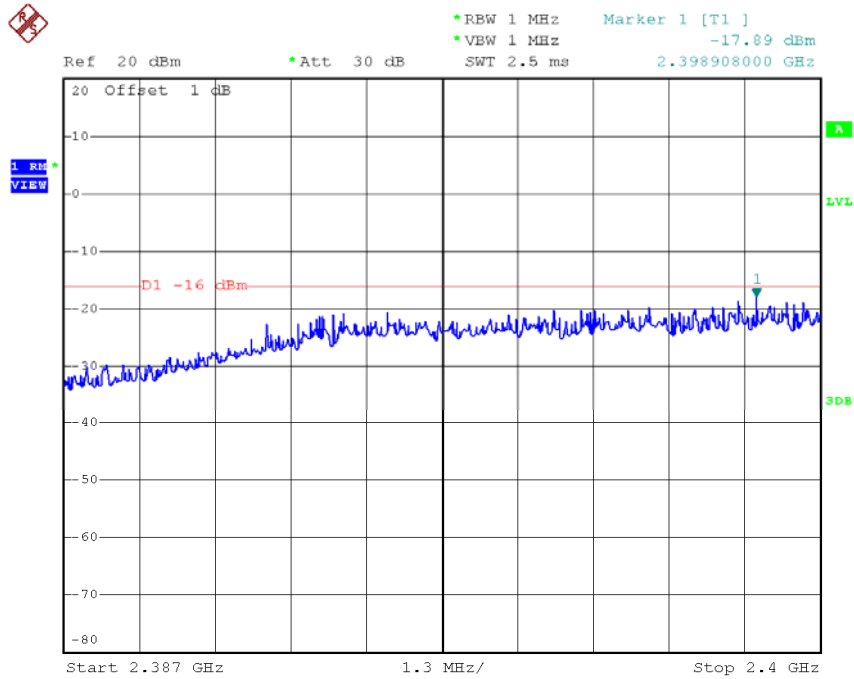

Date: 13.NOV.2015 18:14:27

Normal Voltage CH01 Frequency Band 4 (2483.5 MHz \cong f < 2496.5 MHz)

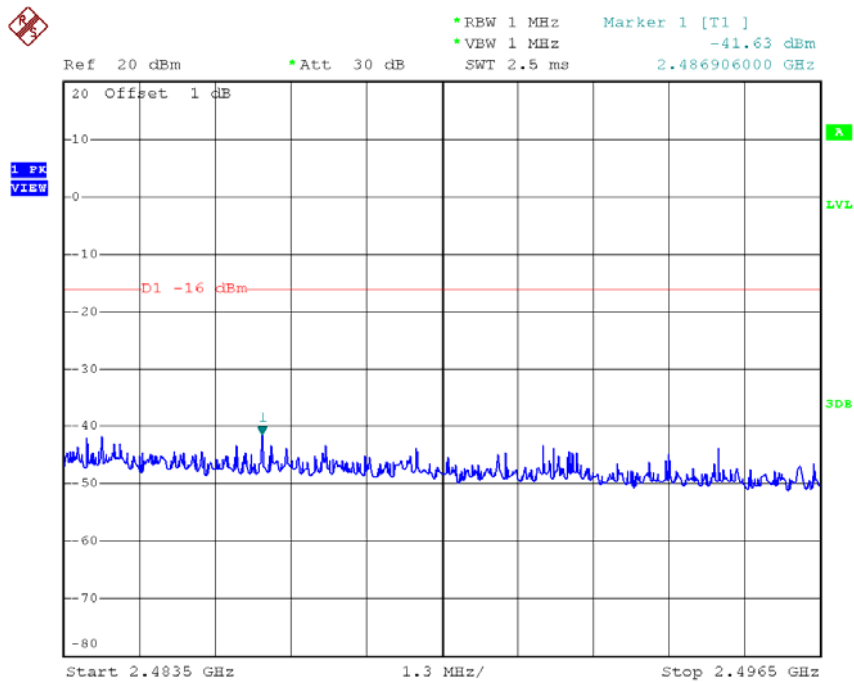

Date: 13.NOV.2015 17:57:38

Normal Voltage
CH01 Frequency Band 5 (2496.5 MHz \leq f < 12.5 GHz)

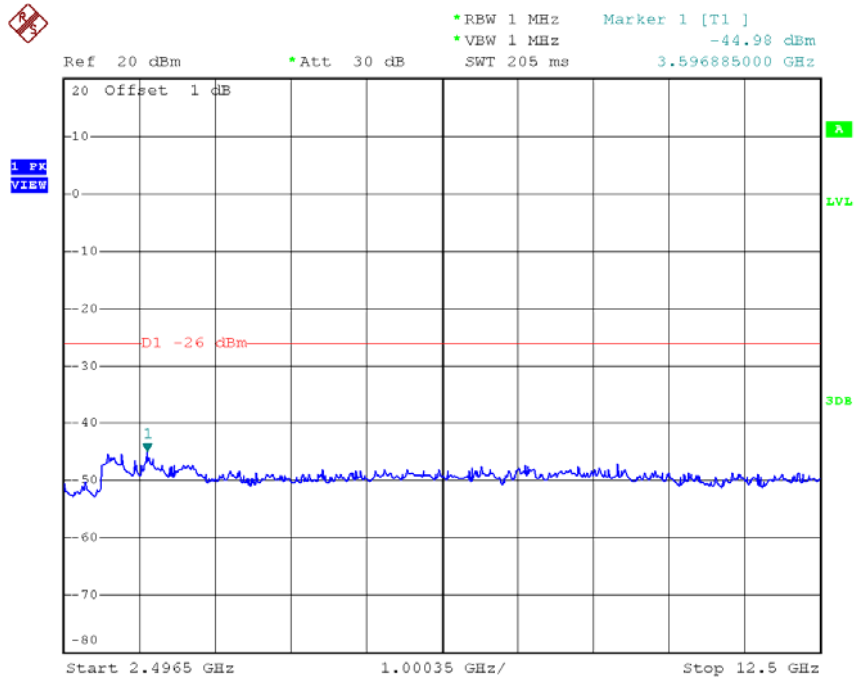

Date: 13.NOV.2015 17:57:48

Normal Voltage
CH07 Frequency Band 1 (30 MHz \leq f \leq 1000 MHz)

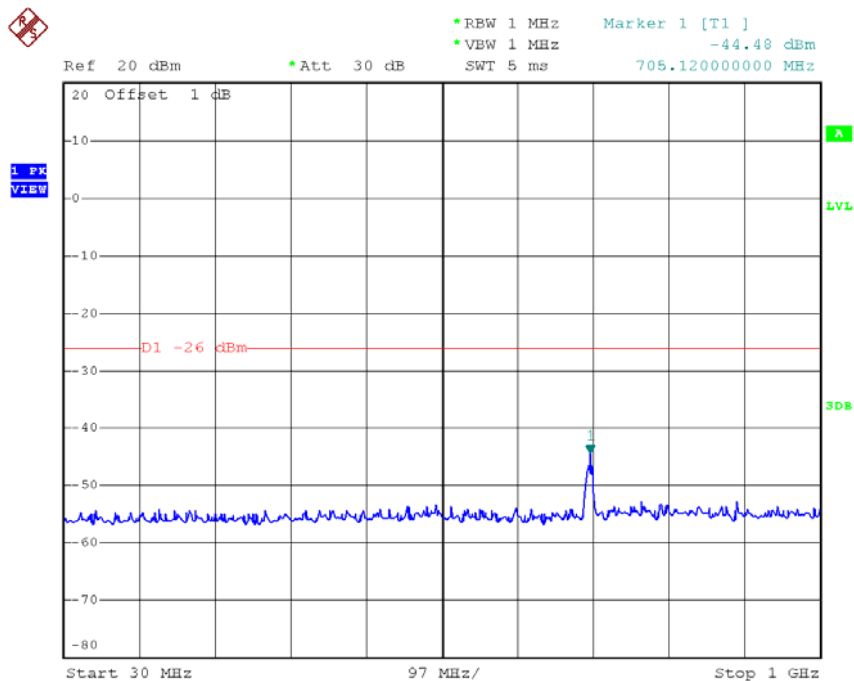

Date: 13.NOV.2015 18:40:56

Normal Voltage
CH07 Frequency Band 2 (1000 MHz < f ≤ 2387 MHz)

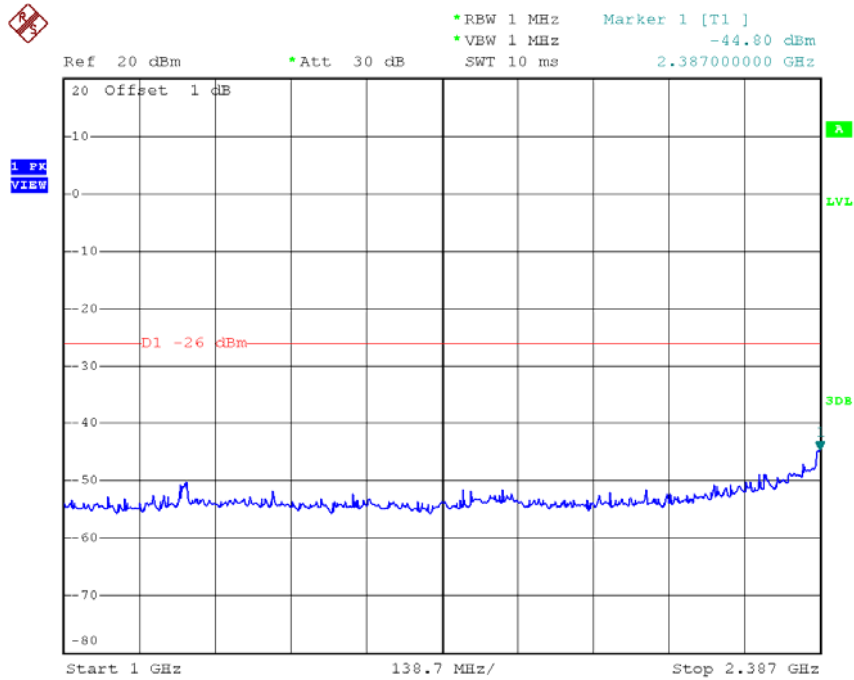

Date: 13.NOV.2015 18:41:07

Normal Voltage
CH07 Frequency Band 3 (2387 MHz ≤ f < 2400 MHz)

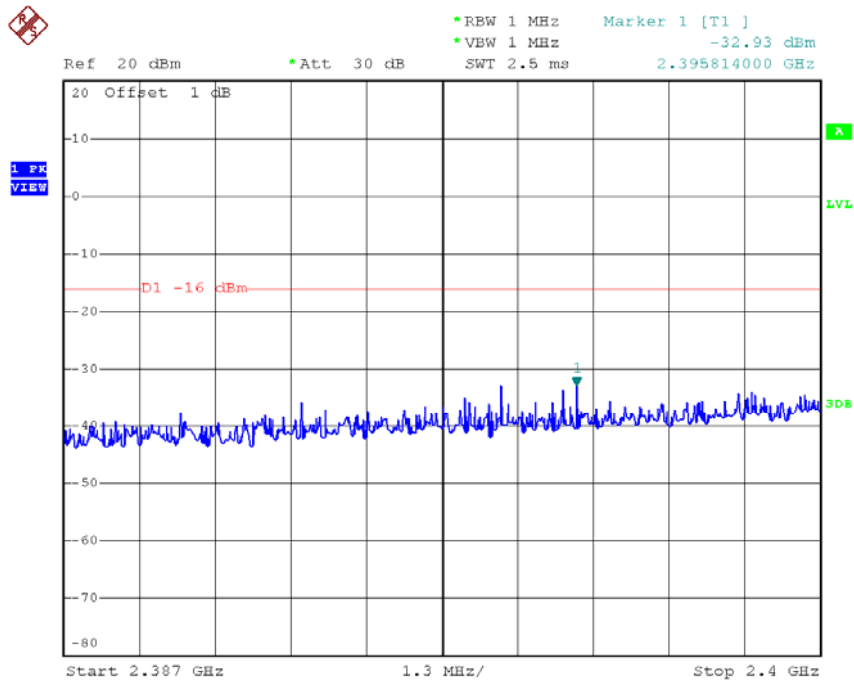

Date: 13.NOV.2015 18:41:18

Normal Voltage

CH07 Frequency Band 4 ($2483.5 \text{ MHz} \leq f < 2496.5 \text{ MHz}$)

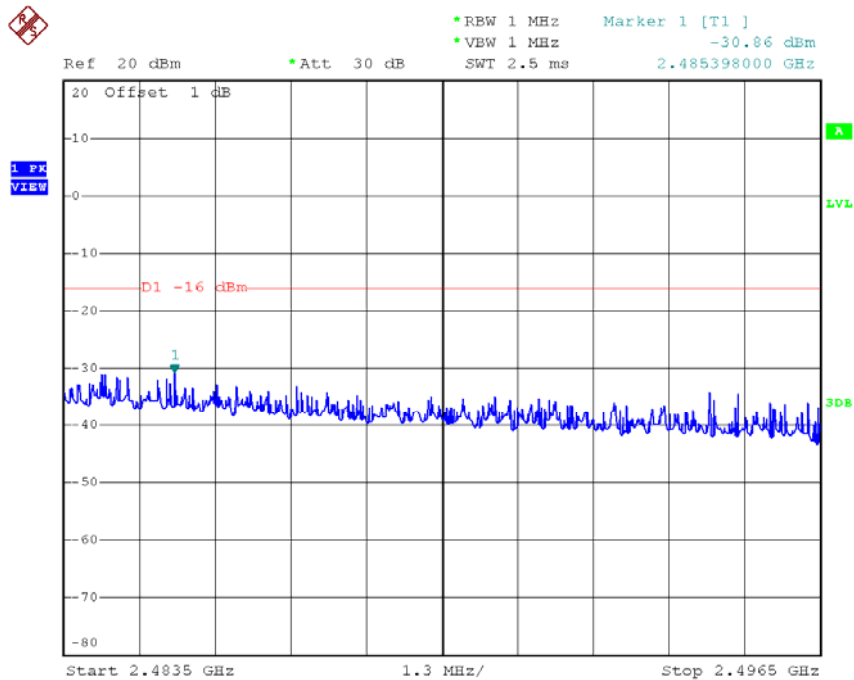

Date: 13.NOV.2015 18:41:28

Normal Voltage

CH07 Frequency Band 5 ($2496.5 \text{ MHz} \leq f < 12.5 \text{ GHz}$)

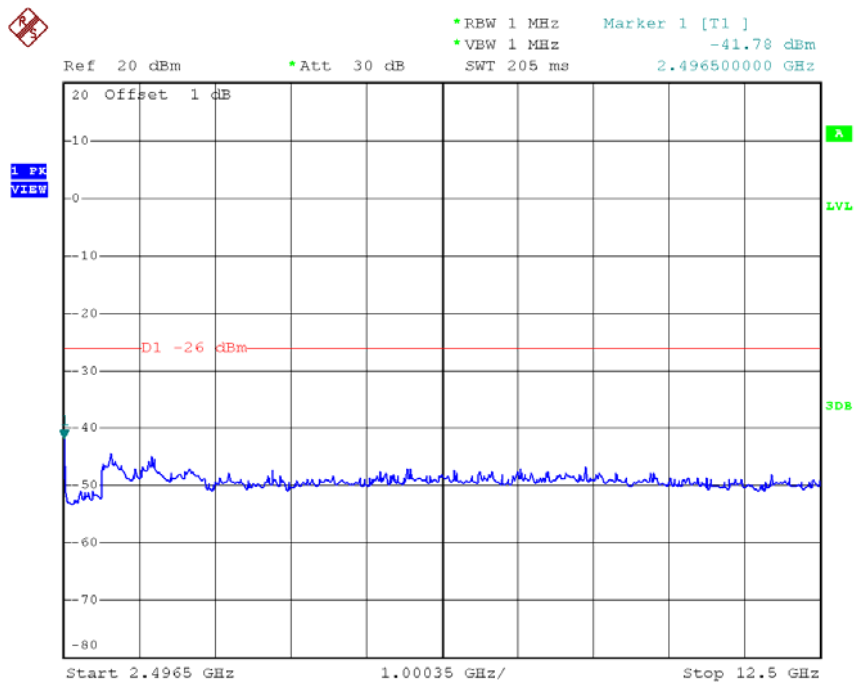

Date: 13.NOV.2015 18:41:39

Normal Voltage CH13 Frequency Band 1 (30 MHz \leq f \leq 1000 MHz)

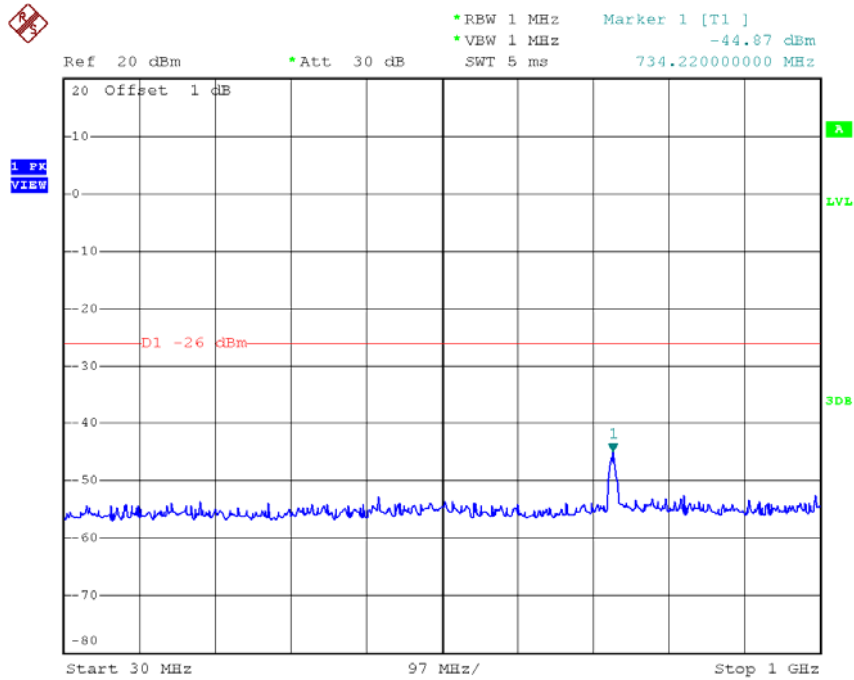

Date: 13.NOV.2015 18:57:19

Normal Voltage CH13 Frequency Band 2 (1000 MHz < f \leq 2387 MHz)

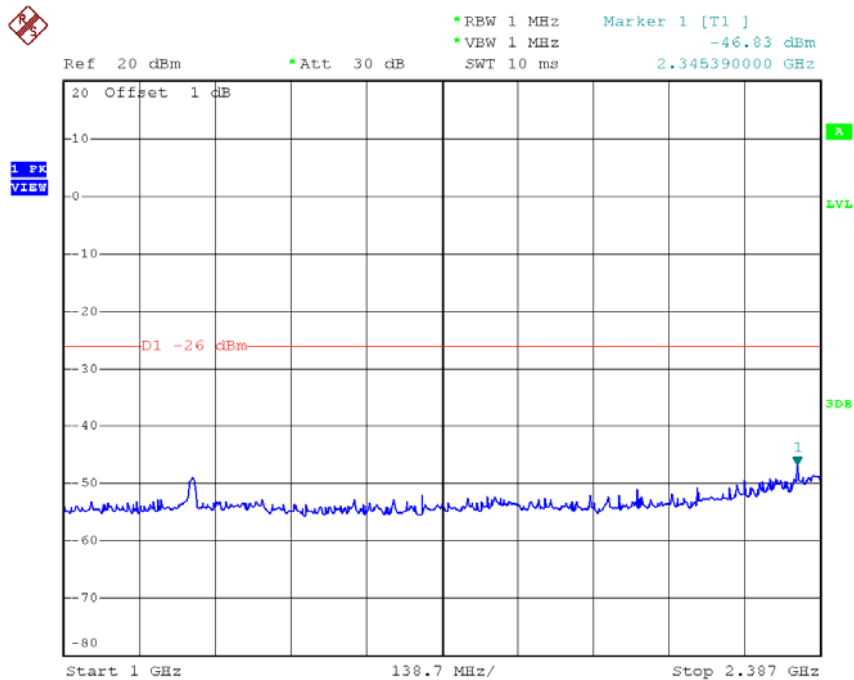

Date: 13.NOV.2015 18:57:30

High Voltage CH01 Frequency Band 3 (2387 MHz \cong f < 2400 MHz)

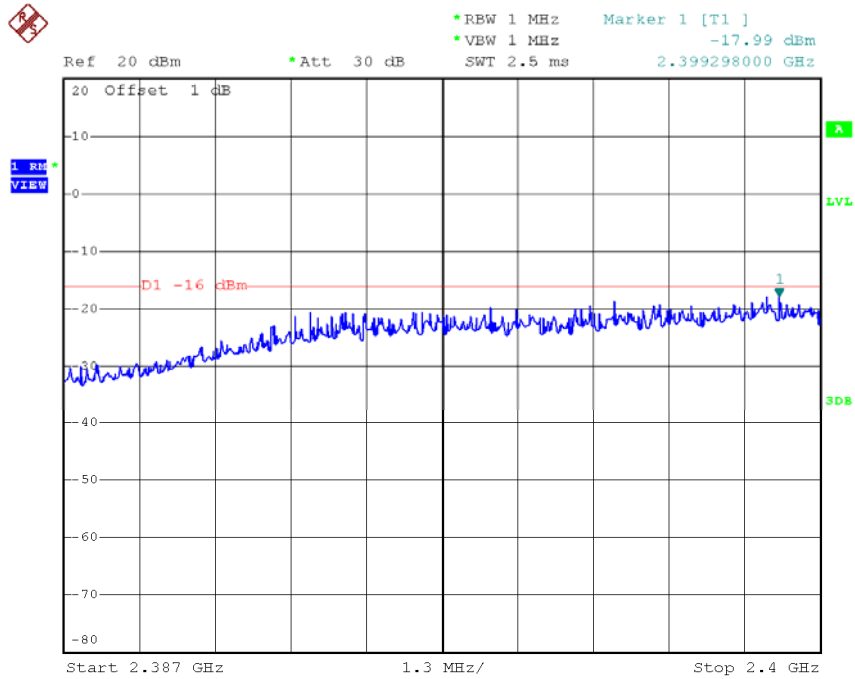

Date: 13.NOV.2015 18:12:45

High Voltage CH01 Frequency Band 4 (2483.5 MHz \cong f < 2496.5 MHz)

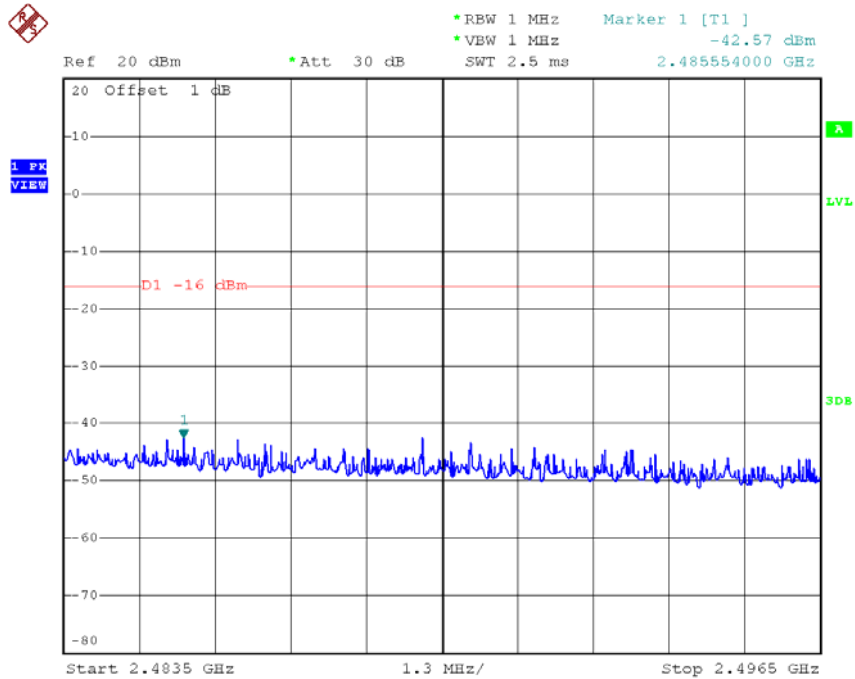

Date: 13.NOV.2015 17:56:45

High Voltage CH01 Frequency Band 5 (2496.5 MHz \leq f < 12.5 GHz)

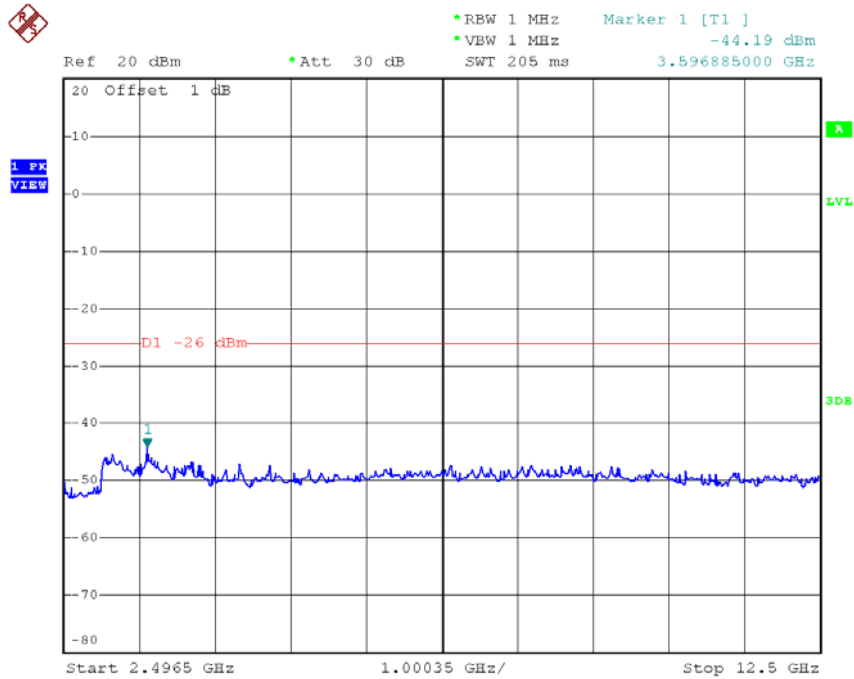

Date: 13.NOV.2015 17:56:55

High Voltage CH07 Frequency Band 1 (30 MHz \leq f \leq 1000 MHz)

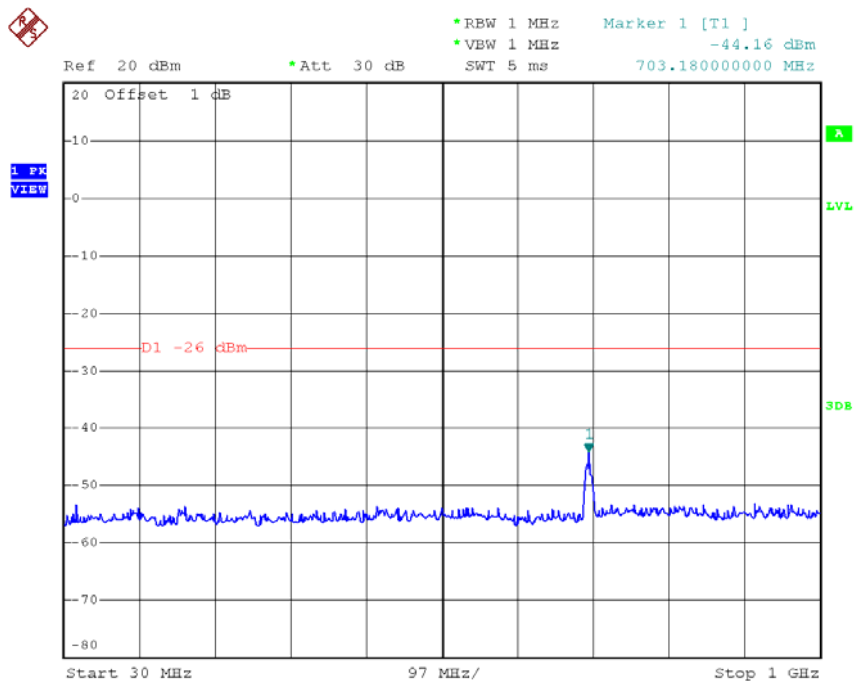

Date: 13.NOV.2015 18:42:06

High Voltage

CH07 Frequency Band 2 (1000 MHz $f \leq 2387 \text{ MHz}$)

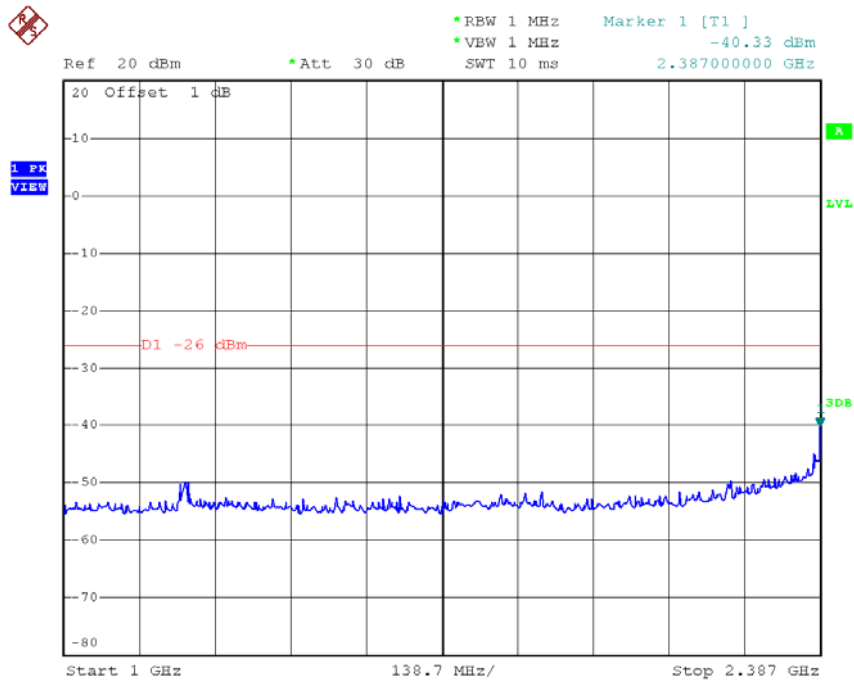

Date: 13.NOV.2015 18:42:17

High Voltage

CH07 Frequency Band 3 (2387 MHz $\leq f < 2400 \text{ MHz}$)

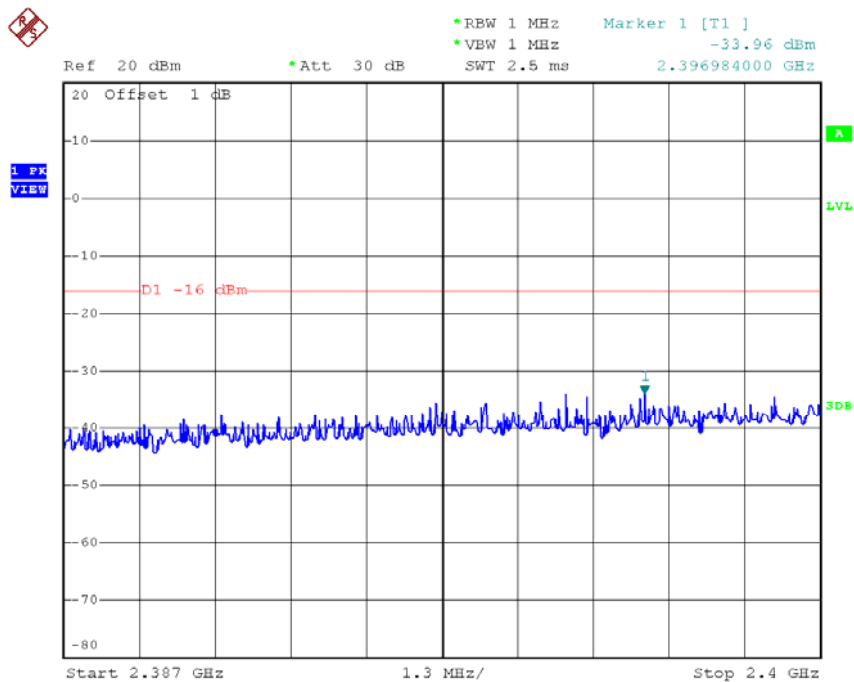

Date: 13.NOV.2015 18:42:27

High Voltage CH13 Frequency Band 3 (2387 MHz \leq f < 2400 MHz)

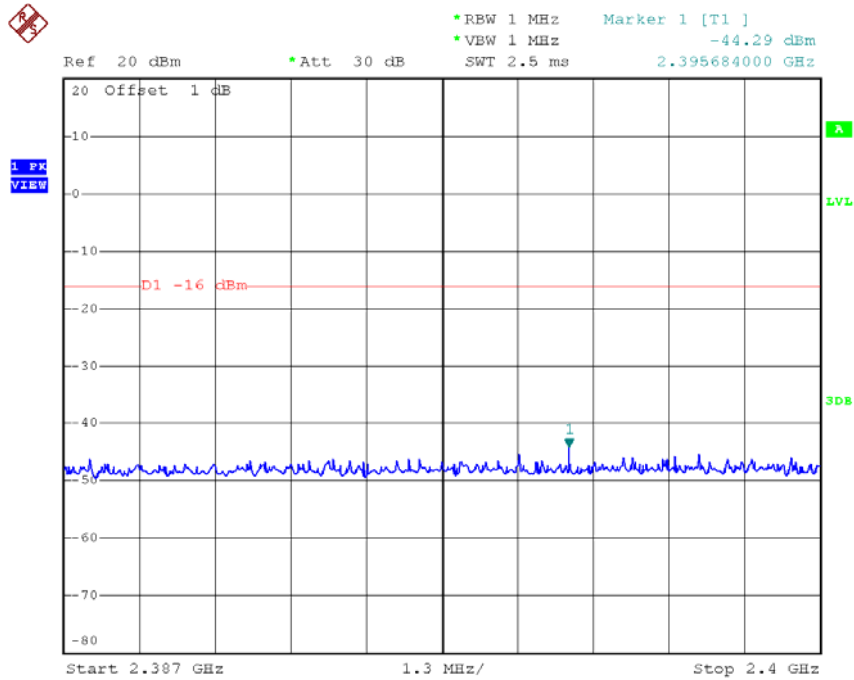

Date: 13.NOV.2015 18:56:38

High Voltage CH13 Frequency Band 4 (2483.5 MHz \leq f < 2496.5 MHz)

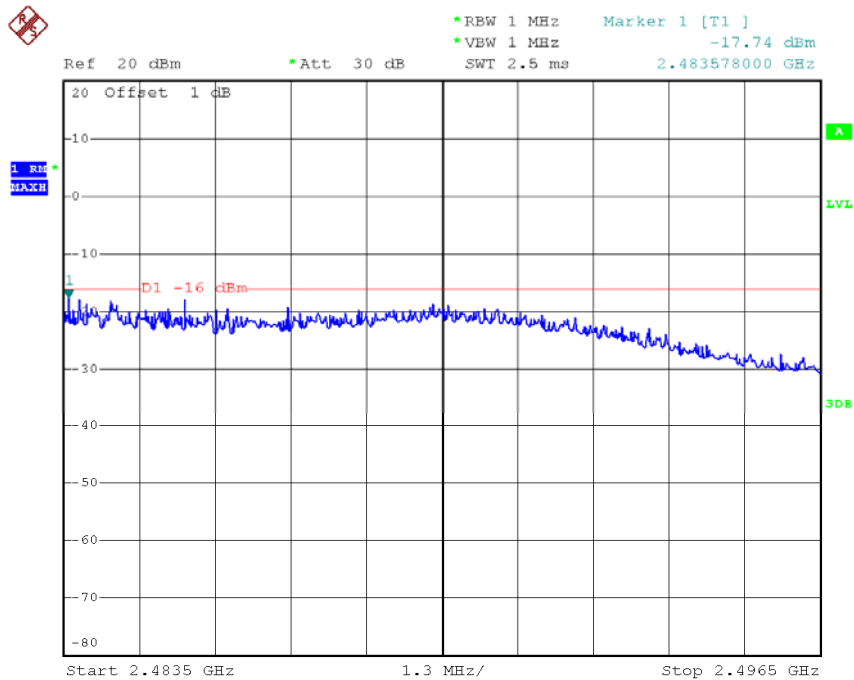

Date: 13.NOV.2015 18:59:19

High Voltage CH13 Frequency Band 5 (2496.5 MHz \cong f <12.5 GHz)

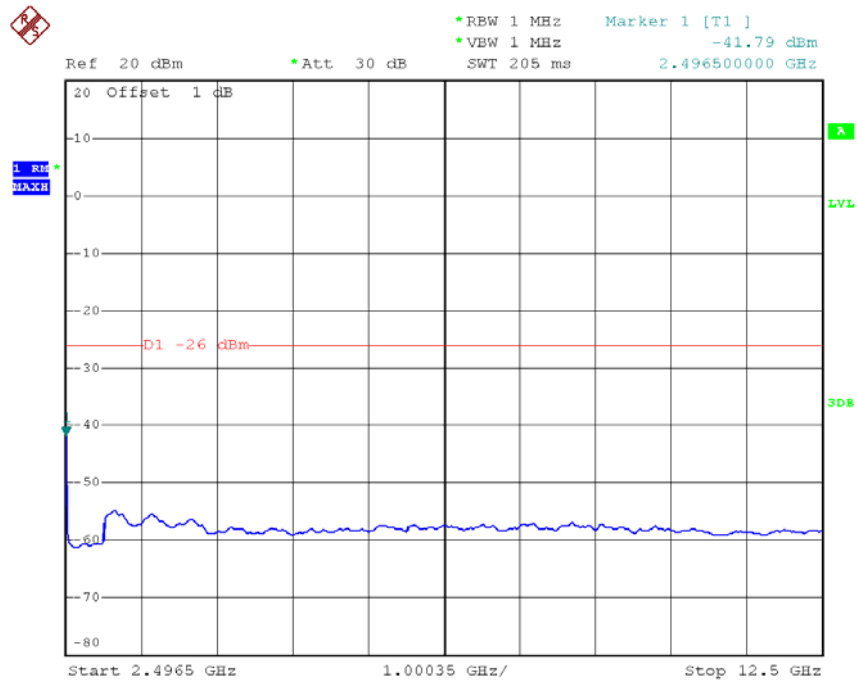

Date: 14.NOV.2015 14:11:15

Low Voltage

CH01 Frequency Band 1 (30 MHz \leq f \leq 1000 MHz)

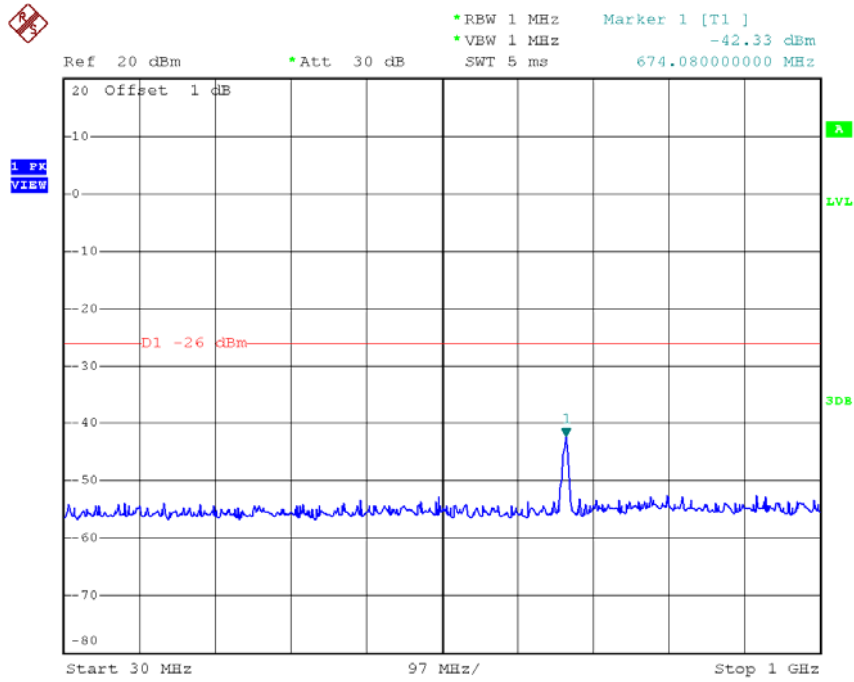

Date: 13.NOV.2015 17:58:00

Low Voltage

CH01 Frequency Band 2 (1000 MHz < f \leq 2387 MHz)

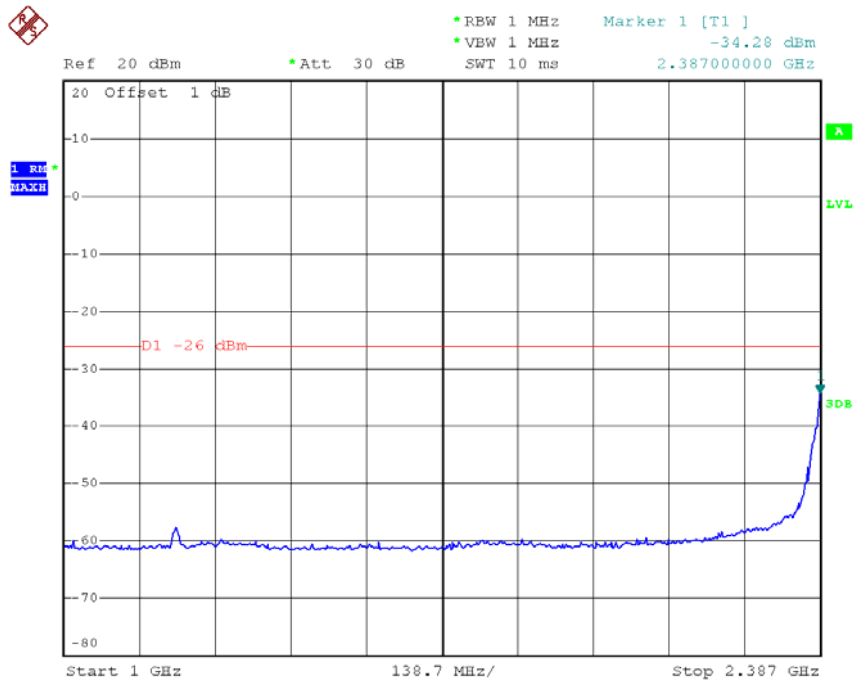

Date: 13.NOV.2015 18:02:58

Low Voltage CH01 Frequency Band 3 (2387 MHz \leq f < 2400 MHz)

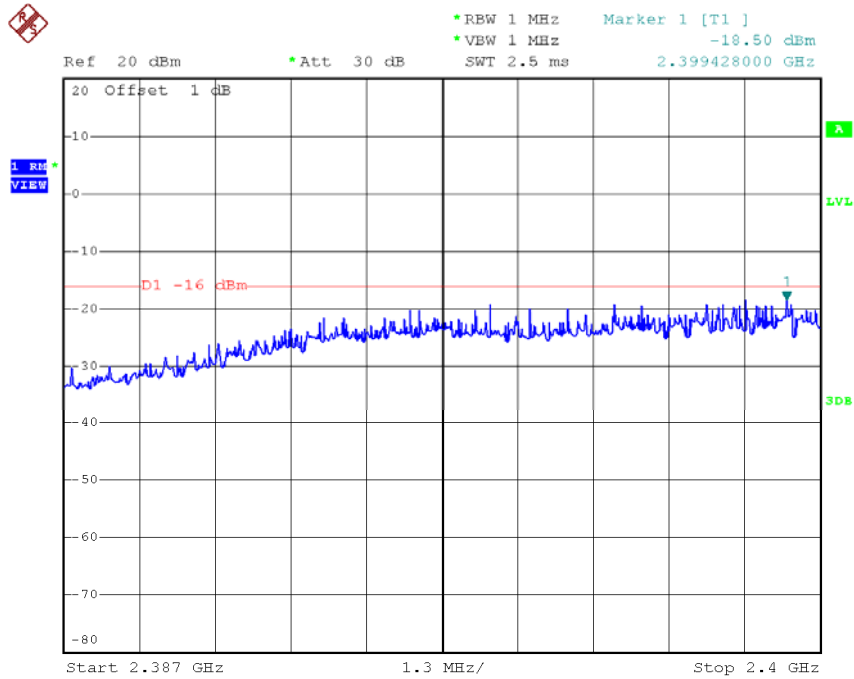

Date: 13.NOV.2015 18:13:14

Low Voltage CH01 Frequency Band 4 (2483.5 MHz \leq f < 2496.5 MHz)

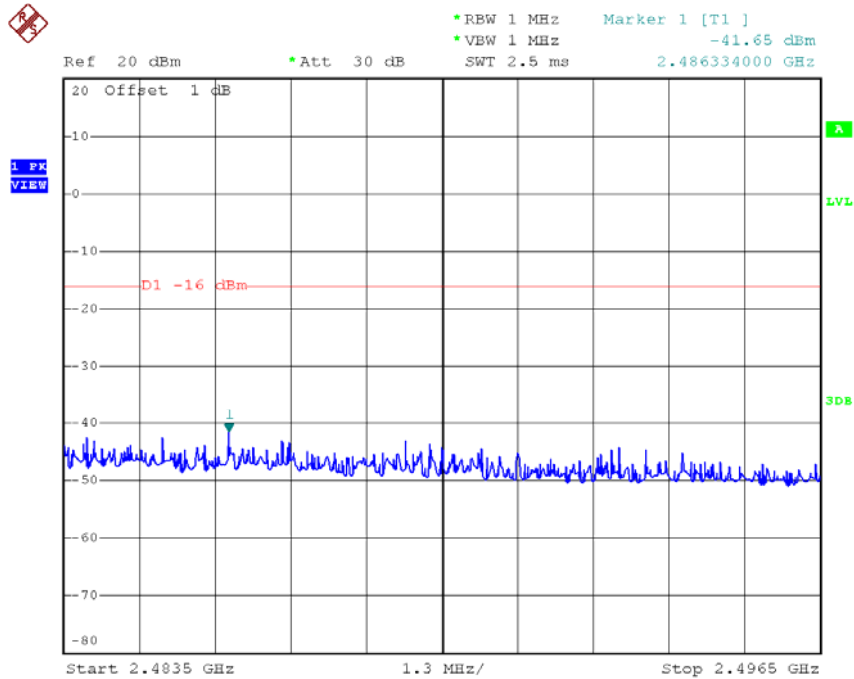

Date: 13.NOV.2015 17:58:29

Low Voltage

CH01 Frequency Band 5 (2496.5 MHz \leq f < 12.5 GHz)

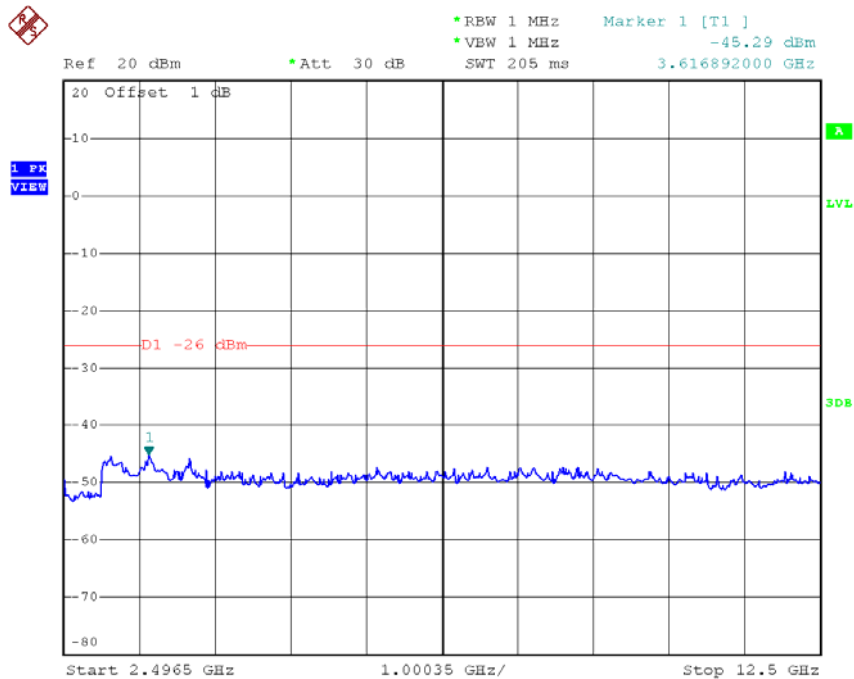

Date: 13.NOV.2015 17:58:39

Low Voltage

CH07 Frequency Band 1 (30 MHz \leq f \leq 1000 MHz)

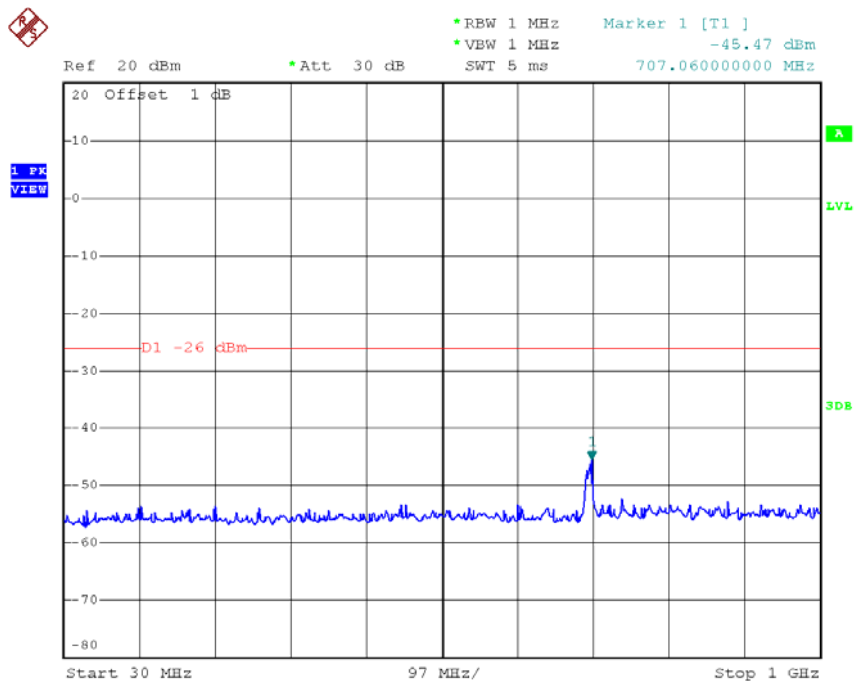

Date: 13.NOV.2015 18:43:01

Low Voltage

CH07 Frequency Band 2 (1000 MHz $f \leq 2387\text{ MHz}$)

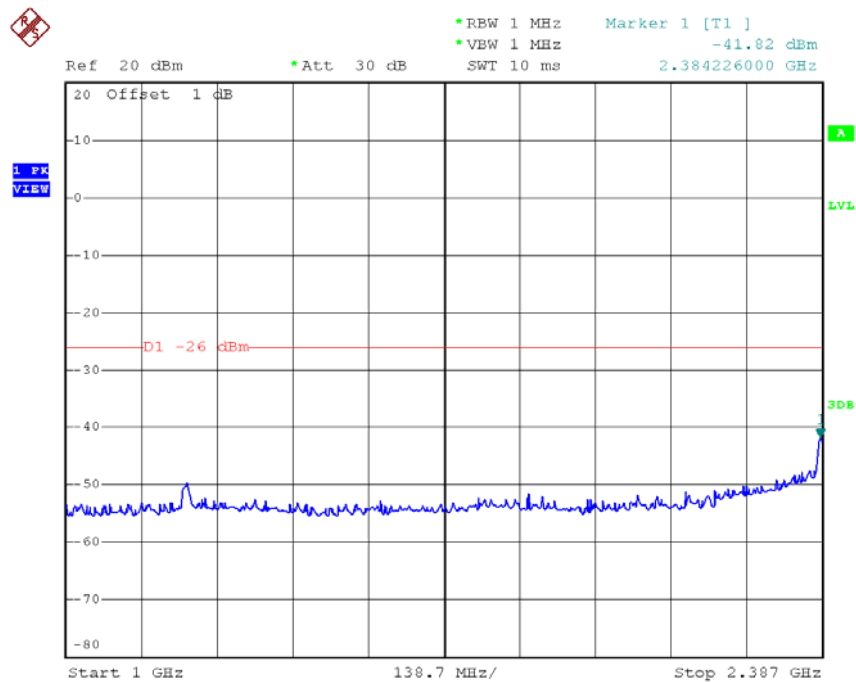

Date: 13.NOV.2015 18:43:12

Low Voltage

CH07 Frequency Band 3 (2387 MHz $\leq f < 2400\text{ MHz}$)

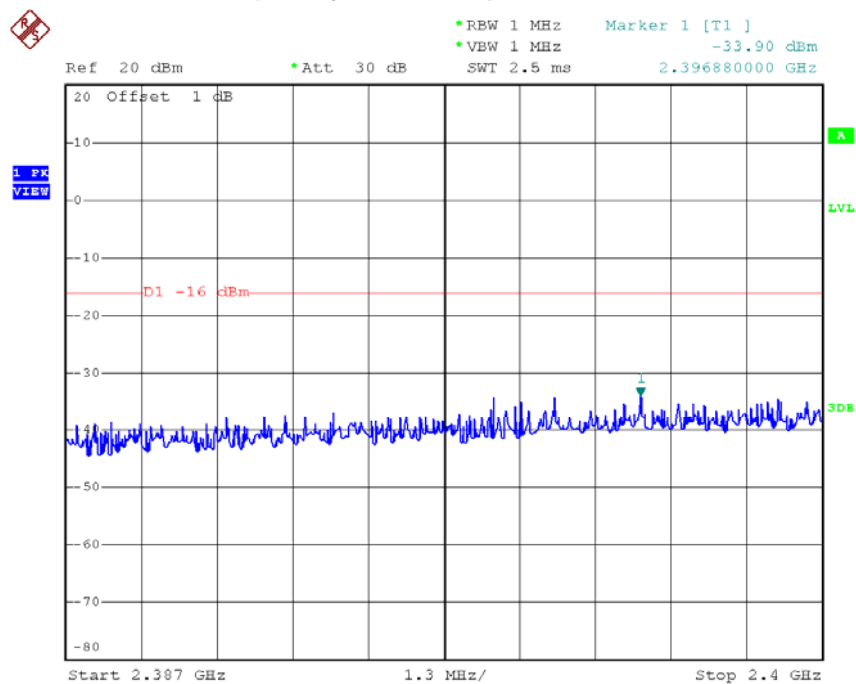

Date: 13.NOV.2015 18:43:23

Low Voltage

CH07 Frequency Band 4 ($2483.5 \text{ MHz} \leq f < 2496.5 \text{ MHz}$)

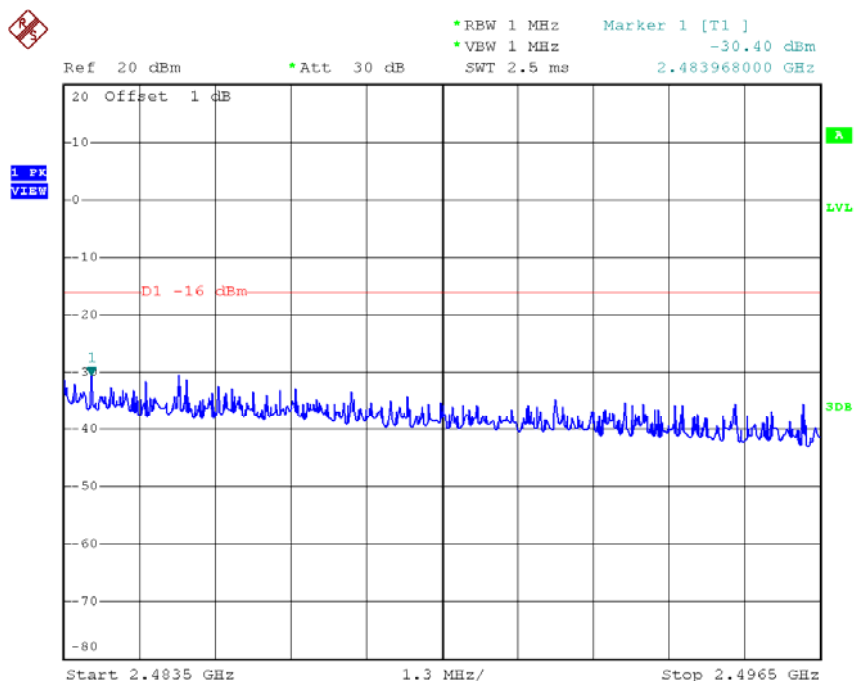

Date: 13.NOV.2015 18:43:33

Low Voltage

CH07 Frequency Band 5 ($2496.5 \text{ MHz} \leq f < 12.5 \text{ GHz}$)

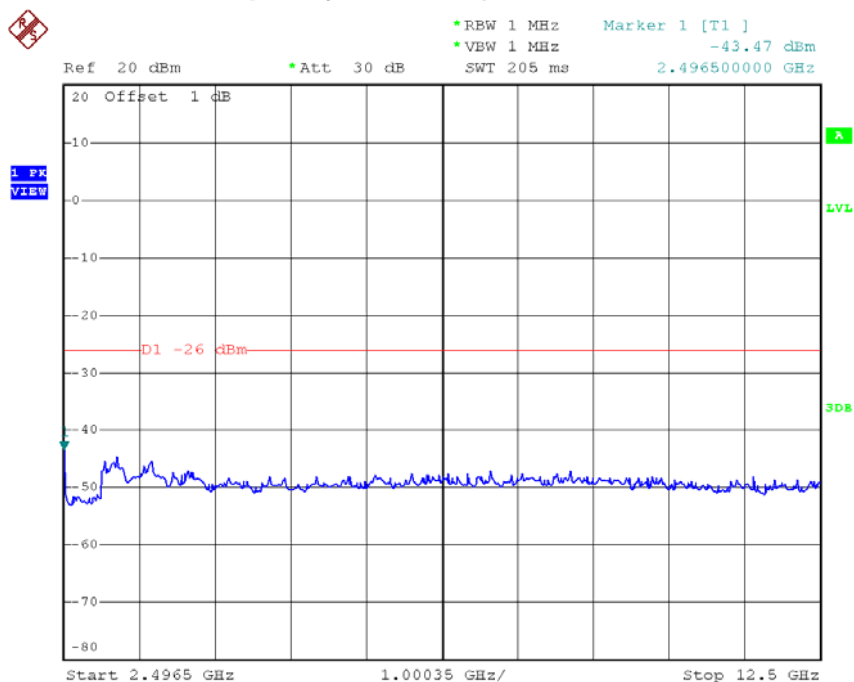

Date: 13.NOV.2015 18:43:44

Low Voltage

CH13 Frequency Band 1 (30 MHz \leq f \leq 1000 MHz)

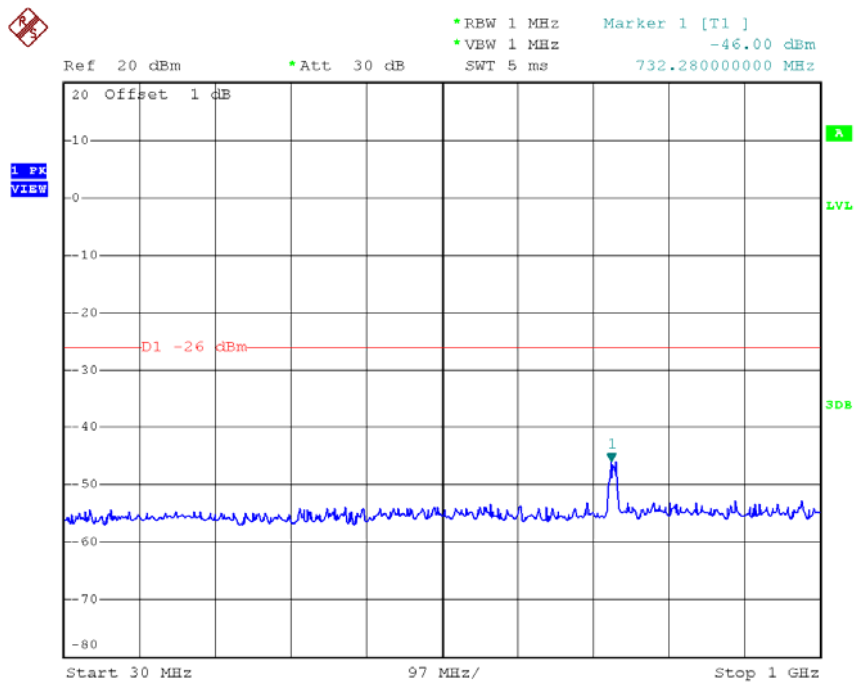

Date: 13.NOV.2015 19:03:48

Low Voltage

CH13 Frequency Band 2 (1000 MHz < f \leq 2387 MHz)

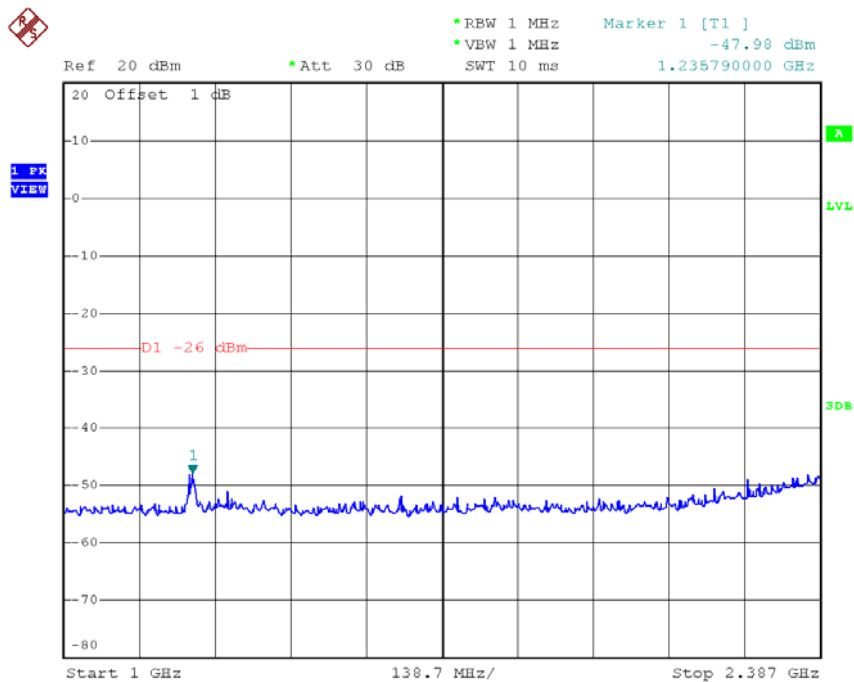

Date: 13.NOV.2015 19:03:59

Low Voltage

CH13 Frequency Band 3 (2387 MHz \leq f < 2400 MHz)

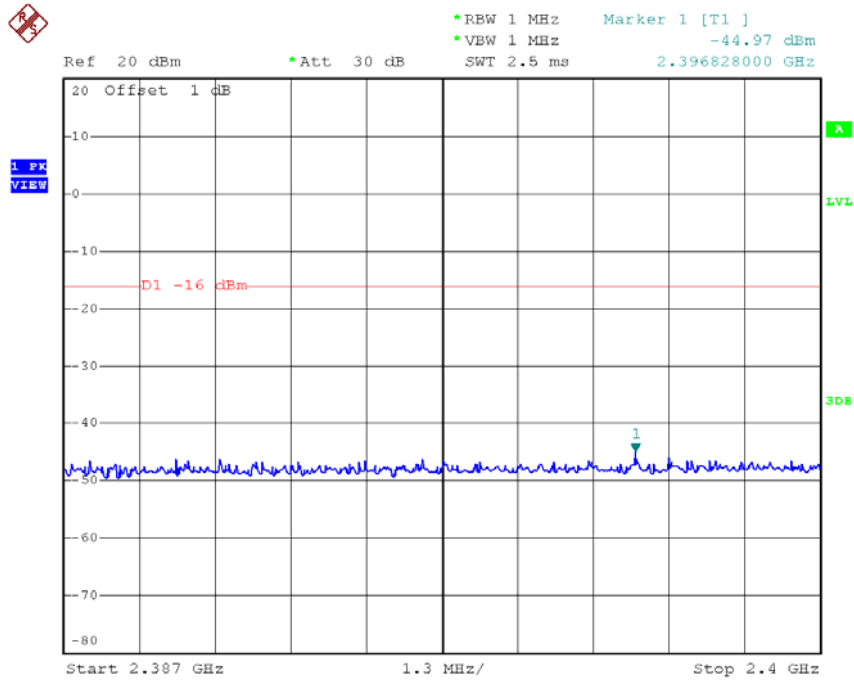

Date: 13.NOV.2015 19:04:10

Low Voltage

CH13 Frequency Band 4 (2483.5 MHz \leq f < 2496.5 MHz)

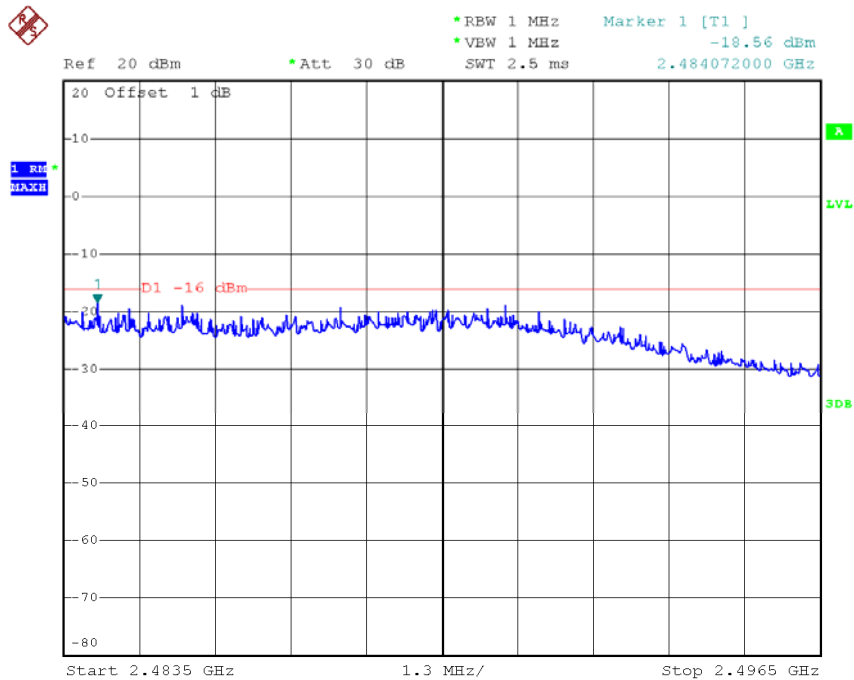

Date: 13.NOV.2015 18:59:59

Low Voltage

CH13 Frequency Band 5 (2496.5 MHz \cong f < 12.5 GHz)

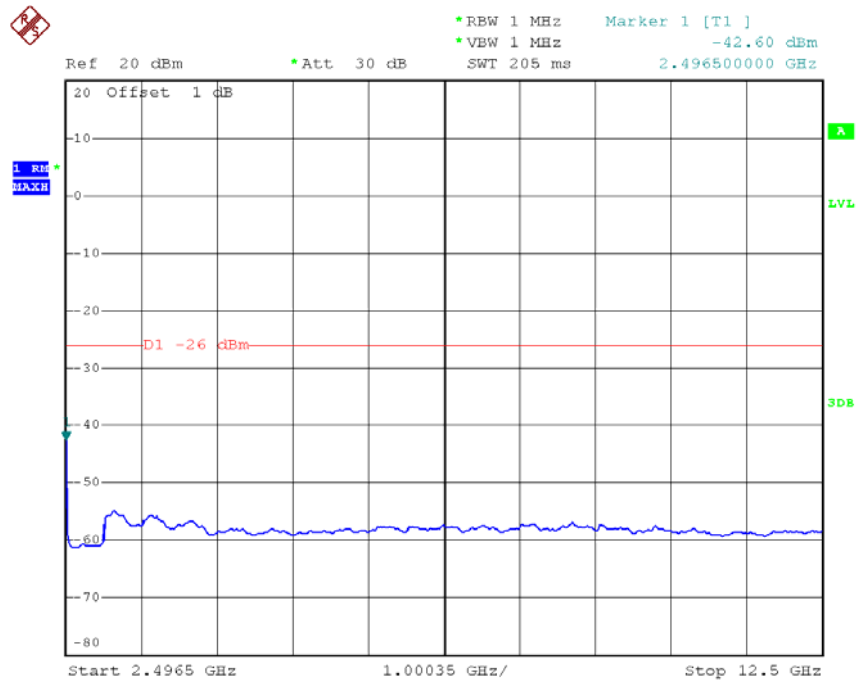

Date: 14.NOV.2015 14:11:29

Test Mode:	802.11n(HT20)/CH01,CH07,CH13
------------	------------------------------

Test Voltage		V	Normal Voltage			Remarks
Test Frequency		MHz	2412	2442	2472	Low/Mid/High of test frequency range
Unwanted Emission Intensity (Power emission within 1MHz bandwidth) (units: μ W)	※ 1	μ W/MHz	0.00984	0.01368	0.01799	Limit \cong 2.5 μ W/MHz (-26 dBm/MHz)
	※ 2	μ W/MHz	1.01158	0.02203	0.01479	Limit \cong 2.5 μ W/MHz (-26 dBm/MHz)
	※ 3	μ W/MHz	8.01678	0.17219	0.02163	Limit \cong 25 μ W/MHz (-16 dBm/MHz)
	※ 4	μ W/MHz	0.02851	0.24547	6.30957	Limit \cong 25 μ W/MHz (-16 dBm/MHz)
	※ 5	μ W/MHz	0.03206	0.04227	1.67109	Limit \cong 2.5 μ W/MHz (-26 dBm/MHz)

Test Voltage		V	High Voltage			Remarks
Test Frequency		MHz	2412	2442	2472	Low/Mid/High of test frequency range
Unwanted Emission Intensity (Power emission within 1MHz bandwidth) (units: μ W)	※ 1	μ W/MHz	0.43053	0.02773	0.01549	Limit \cong 2.5 μ W/MHz (-26 dBm/MHz)
	※ 2	μ W/MHz	1.01158	0.01845	0.01219	Limit \cong 2.5 μ W/MHz (-26 dBm/MHz)
	※ 3	μ W/MHz	8.60994	0.19454	0.02065	Limit \cong 25 μ W/MHz (-16 dBm/MHz)
	※ 4	μ W/MHz	0.04603	0.45604	8.41395	Limit \cong 25 μ W/MHz (-16 dBm/MHz)
	※ 5	μ W/MHz	0.02871	0.02588	1.32130	Limit \cong 2.5 μ W/MHz (-26 dBm/MHz)

Test Voltage		V	Low Voltage			Remarks
Test Frequency		MHz	2412	2442	2472	Low/Mid/High of test frequency range
Unwanted Emission Intensity (Power emission within 1MHz bandwidth) (units: μ W)	※ 1	μ W/MHz	0.01250	0.74131	0.01510	Limit \cong 2.5 μ W/MHz (-26 dBm/MHz)
	※ 2	μ W/MHz	1.74181	0.02183	0.01321	Limit \cong 2.5 μ W/MHz (-26 dBm/MHz)
	※ 3	μ W/MHz	6.56145	0.14028	0.01977	Limit \cong 25 μ W/MHz (-16 dBm/MHz)
	※ 4	μ W/MHz	0.04529	0.38994	7.78037	Limit \cong 25 μ W/MHz (-16 dBm/MHz)
	※ 5	μ W/MHz	0.03296	0.03639	1.44544	Limit \cong 2.5 μ W/MHz (-26 dBm/MHz)

Normal Voltage CH01 Frequency Band 3 (2387 MHz \cong f < 2400 MHz)

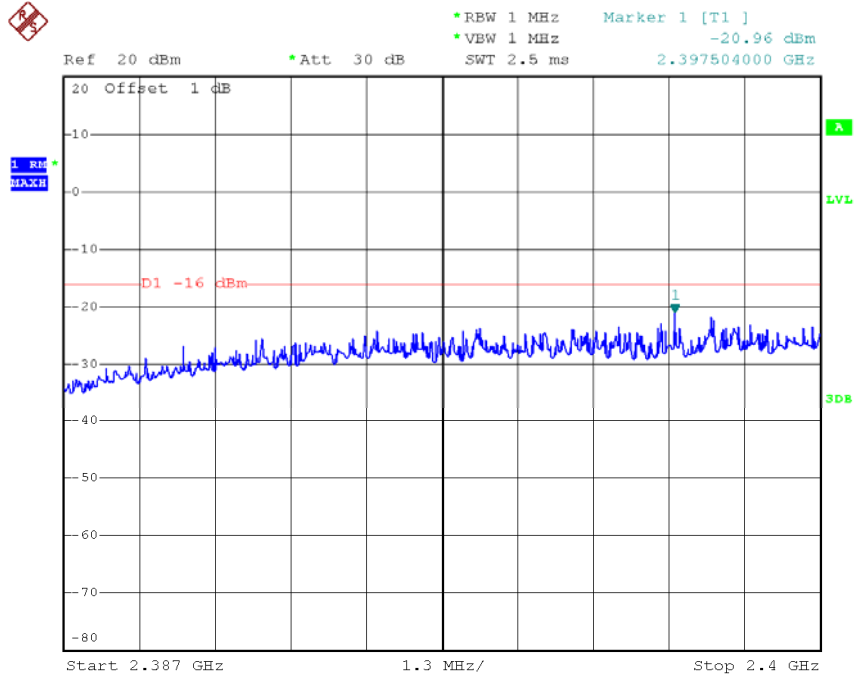

Date: 14.NOV.2015 13:22:38

Normal Voltage CH01 Frequency Band 4 (2483.5 MHz \cong f < 2496.5 MHz)

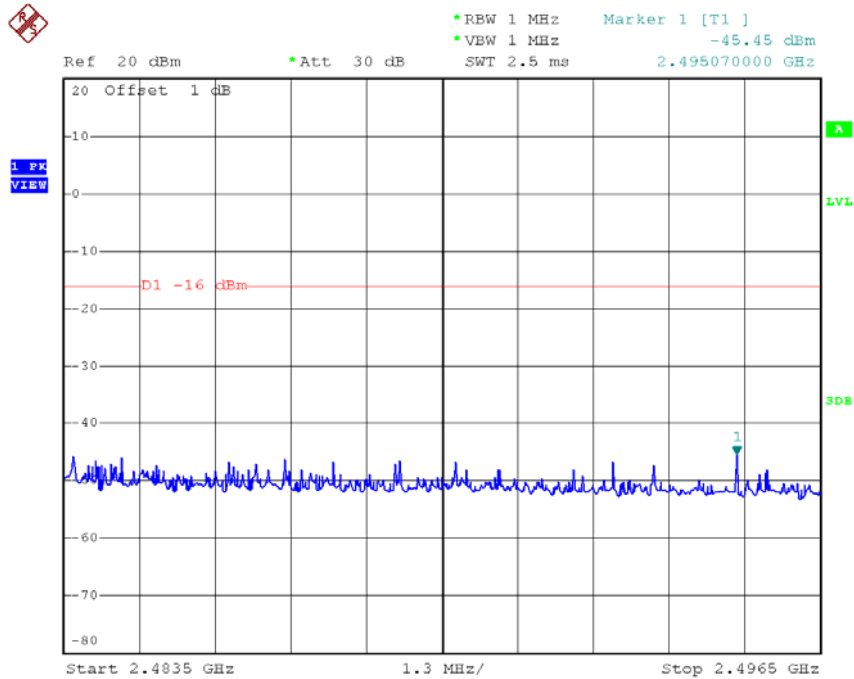

Date: 14.NOV.2015 13:06:57

Normal Voltage
CH01 Frequency Band 5 (2496.5 MHz \leq f < 12.5 GHz)

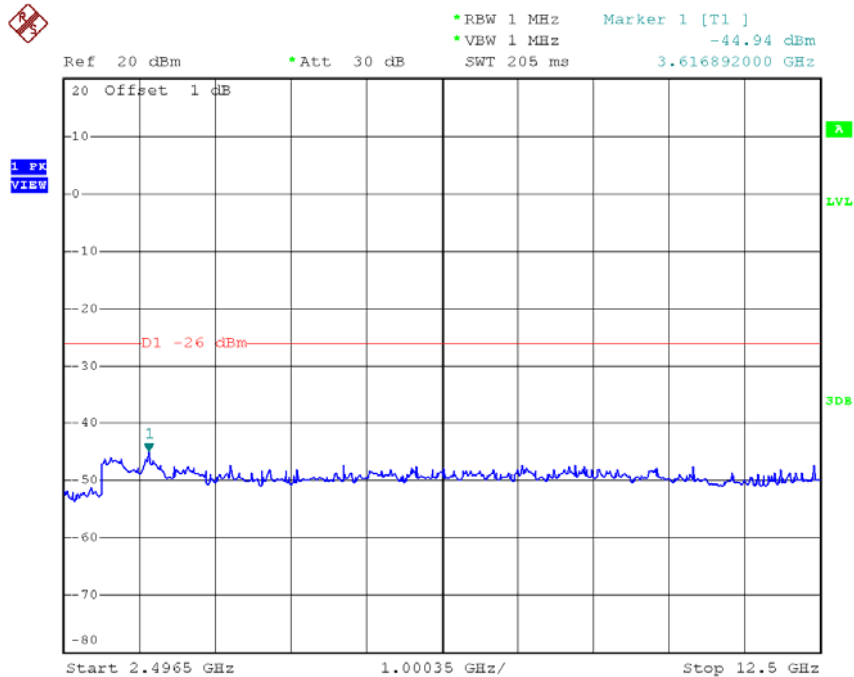

Date: 14.NOV.2015 13:07:08

Normal Voltage
CH07 Frequency Band 1 (30 MHz \leq f \leq 1000 MHz)

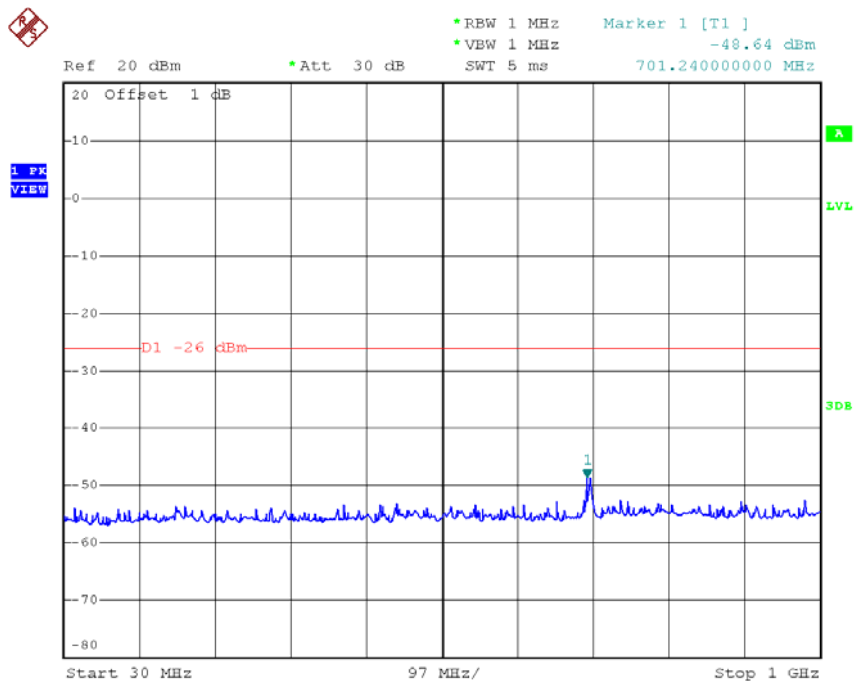

Date: 14.NOV.2015 13:30:44

Normal Voltage

CH07 Frequency Band 2 (1000 MHz < f ≤ 2387 MHz)

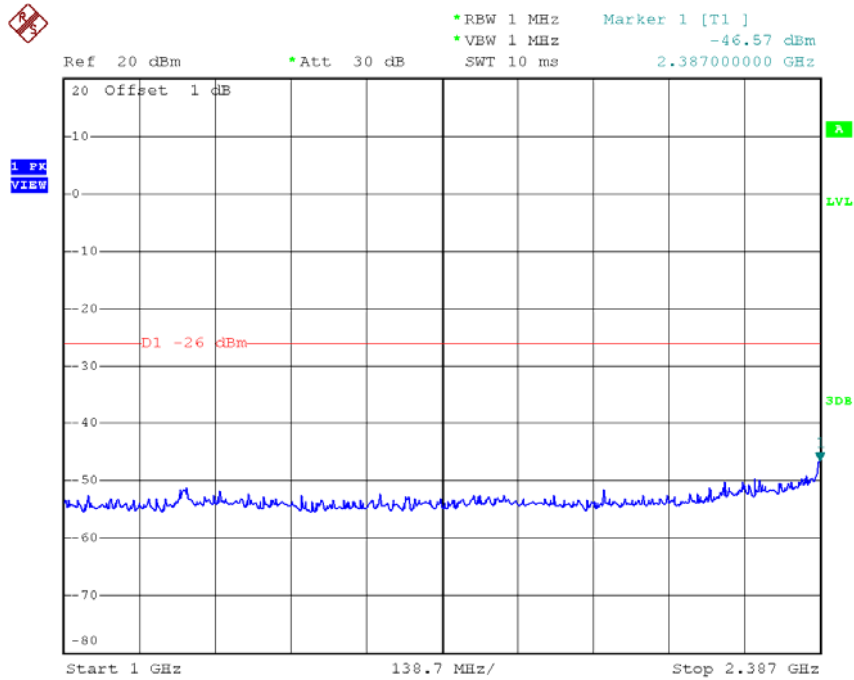

Date: 14.NOV.2015 13:30:55

Normal Voltage

CH07 Frequency Band 3 (2387 MHz ≤ f < 2400 MHz)

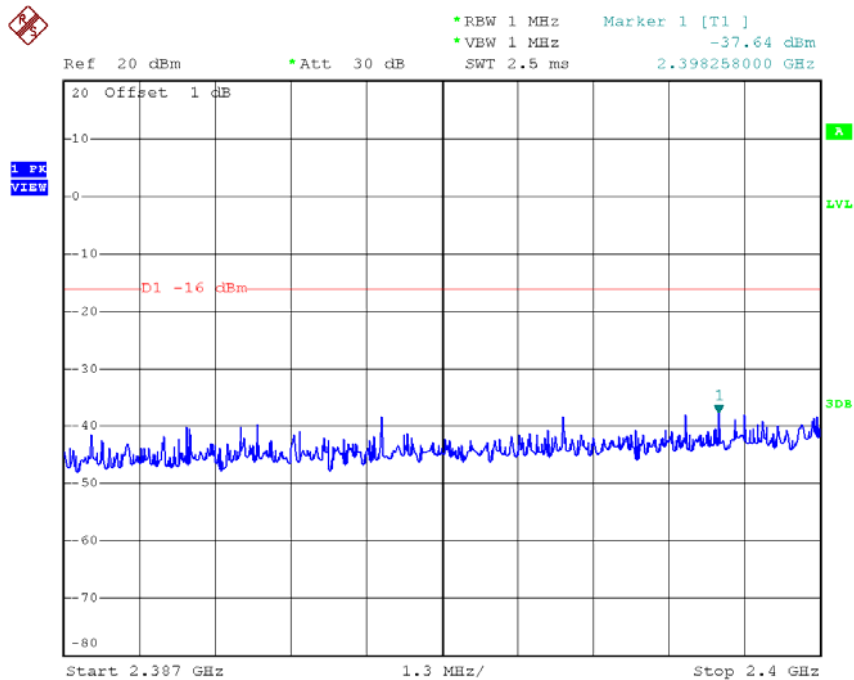

Date: 14.NOV.2015 13:31:06

Normal Voltage

CH07 Frequency Band 4 ($2483.5 \text{ MHz} \leq f < 2496.5 \text{ MHz}$)

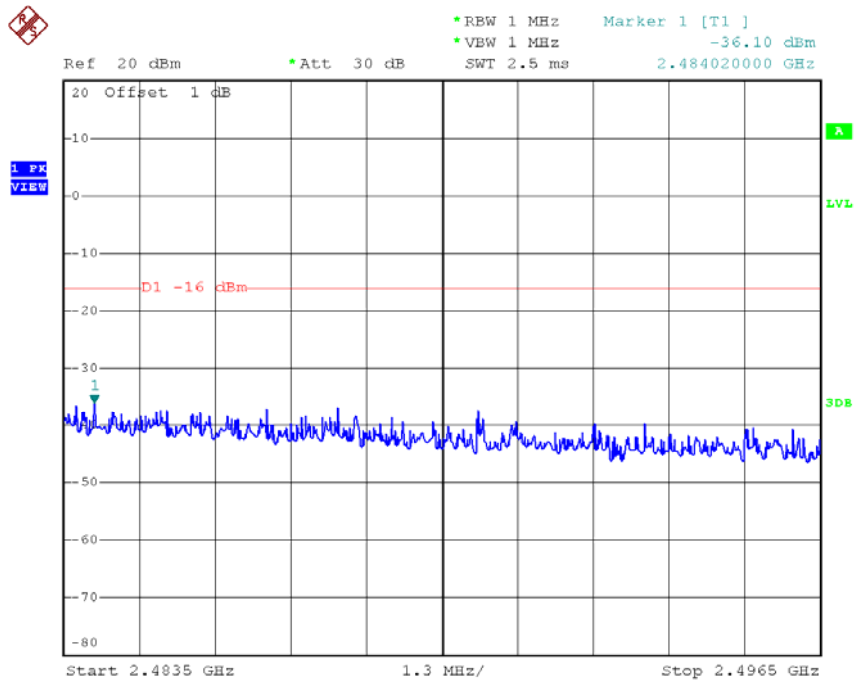

Date: 14.NOV.2015 13:31:16

Normal Voltage

CH07 Frequency Band 5 ($2496.5 \text{ MHz} \leq f < 12.5 \text{ GHz}$)

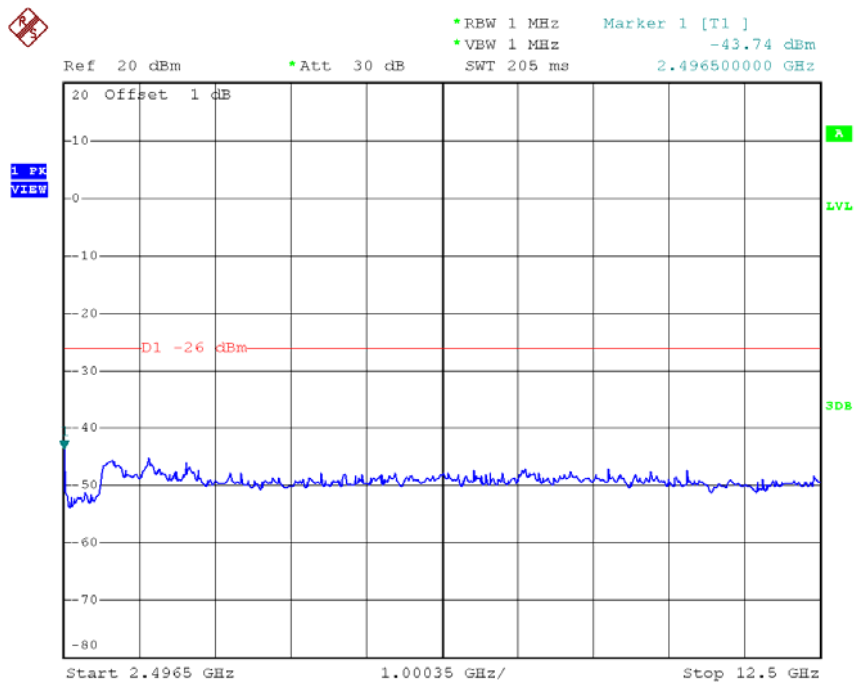

Date: 14.NOV.2015 13:31:27

Normal Voltage CH13 Frequency Band 1 (30 MHz \leq f \leq 1000 MHz)

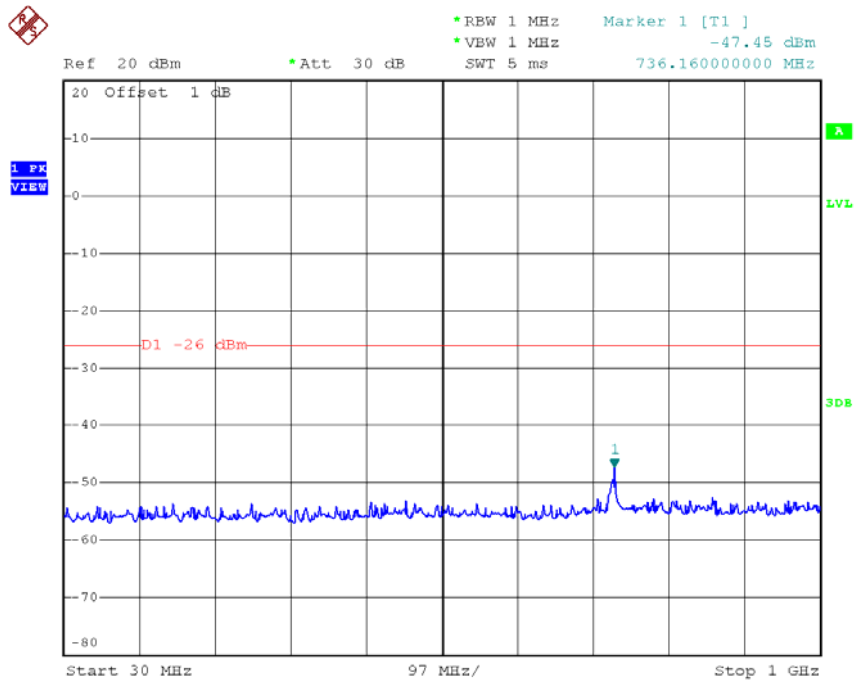

Date: 14.NOV.2015 13:45:13

Normal Voltage CH13 Frequency Band 2 (1000 MHz < f \leq 2387 MHz)

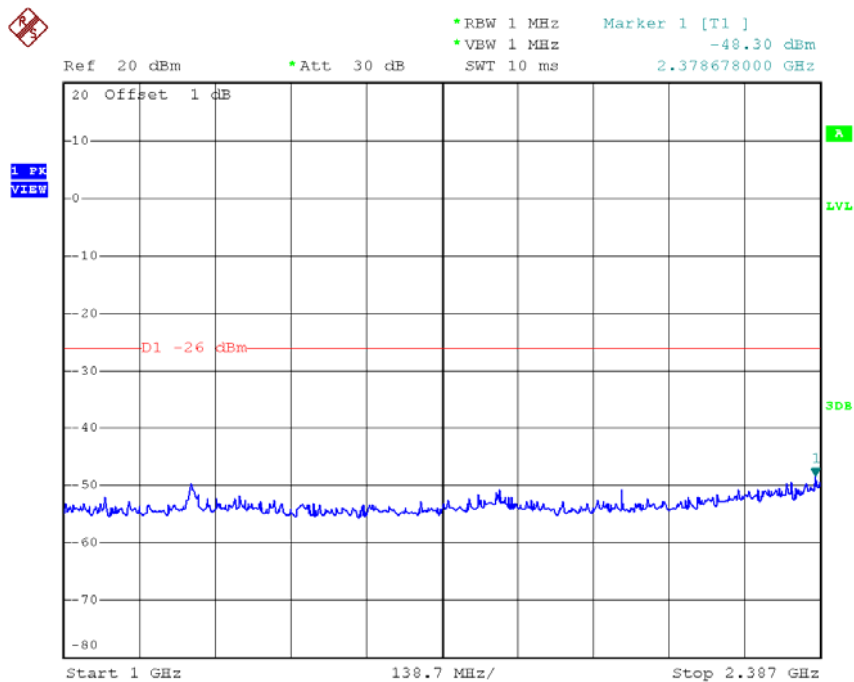

Date: 14.NOV.2015 13:45:24

Normal Voltage
CH13 Frequency Band 3 (2387 MHz \cong f < 2400 MHz)

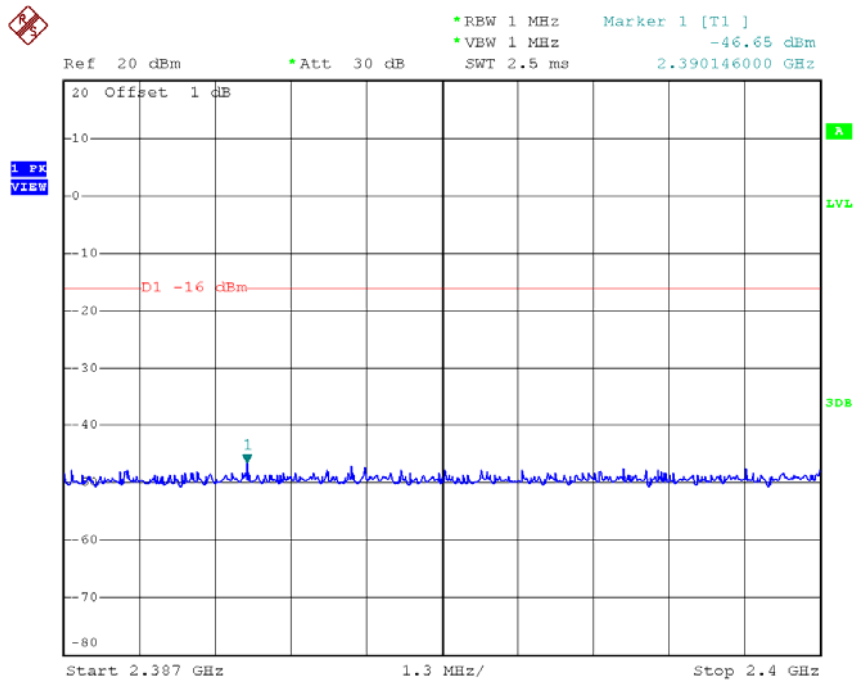

Date: 14.NOV.2015 13:45:35

Normal Voltage
CH13 Frequency Band 4 (2483.5 MHz \cong f < 2496.5 MHz)

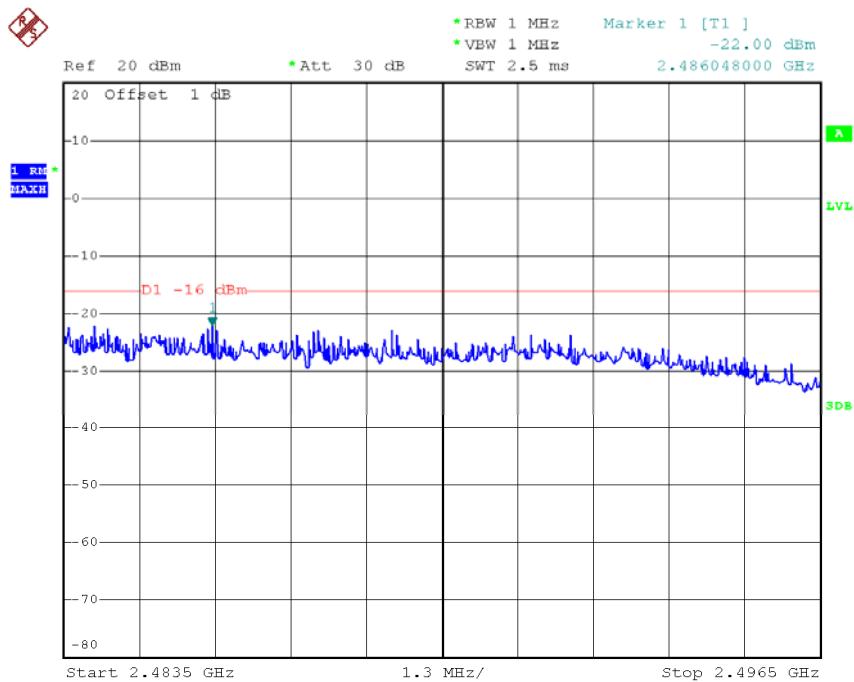

Date: 14.NOV.2015 14:04:38

Normal Voltage CH13 Frequency Band 5 (2496.5 MHz \cong f <12.5 GHz)

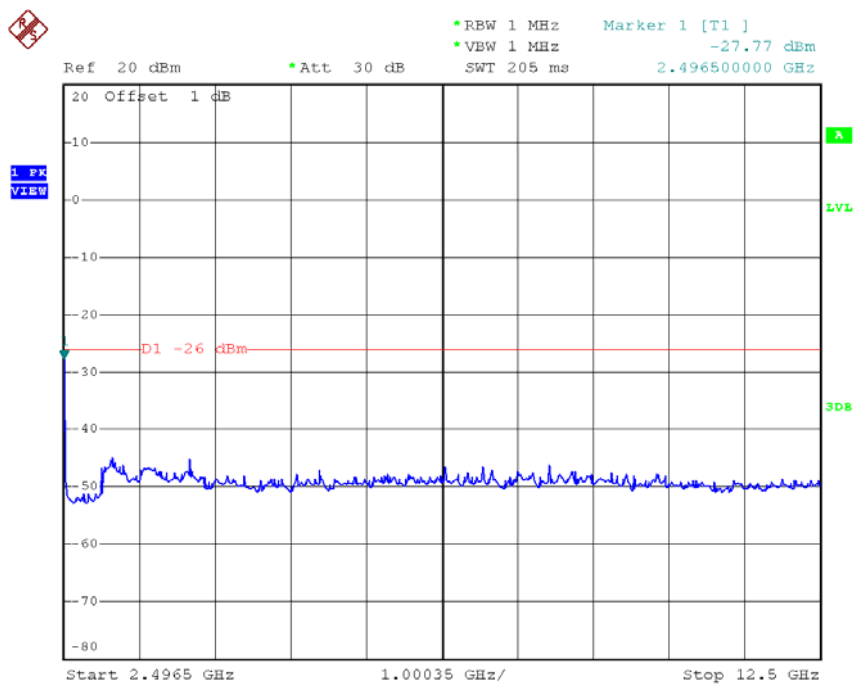

Date: 14.NOV.2015 13:45:56

High Voltage

CH01 Frequency Band 1 (30 MHz \leq f \leq 1000 MHz)

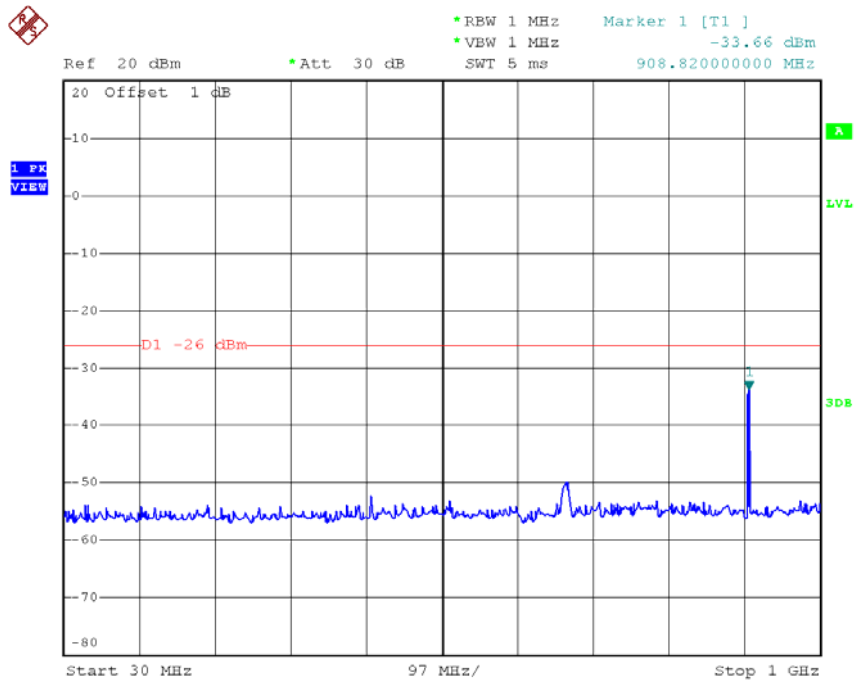

Date: 14.NOV.2015 12:59:15

High Voltage

CH01 Frequency Band 2 (1000 MHz < f \leq 2387 MHz)

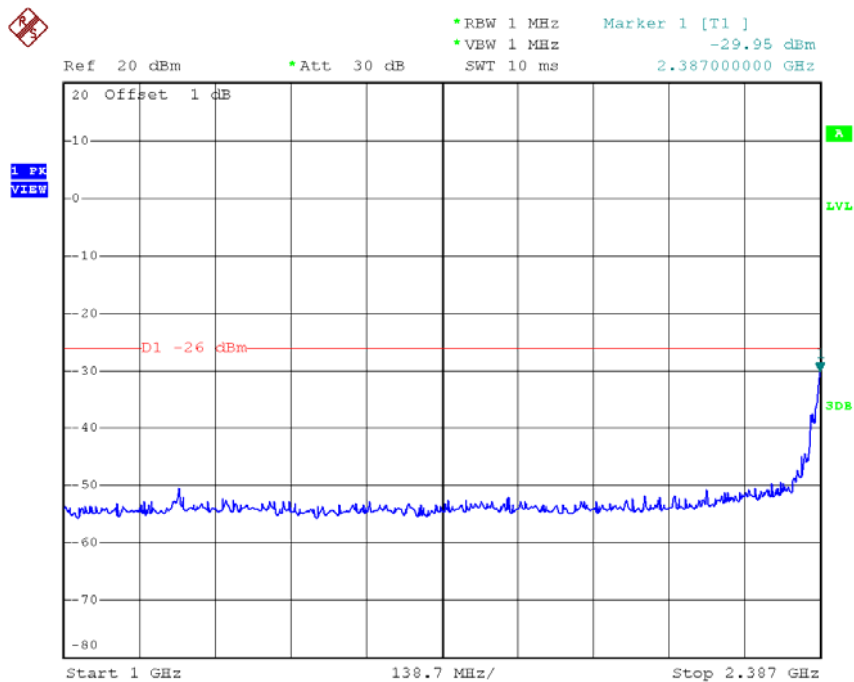

Date: 14.NOV.2015 12:59:25

High Voltage CH01 Frequency Band 3 (2387 MHz \cong f < 2400 MHz)

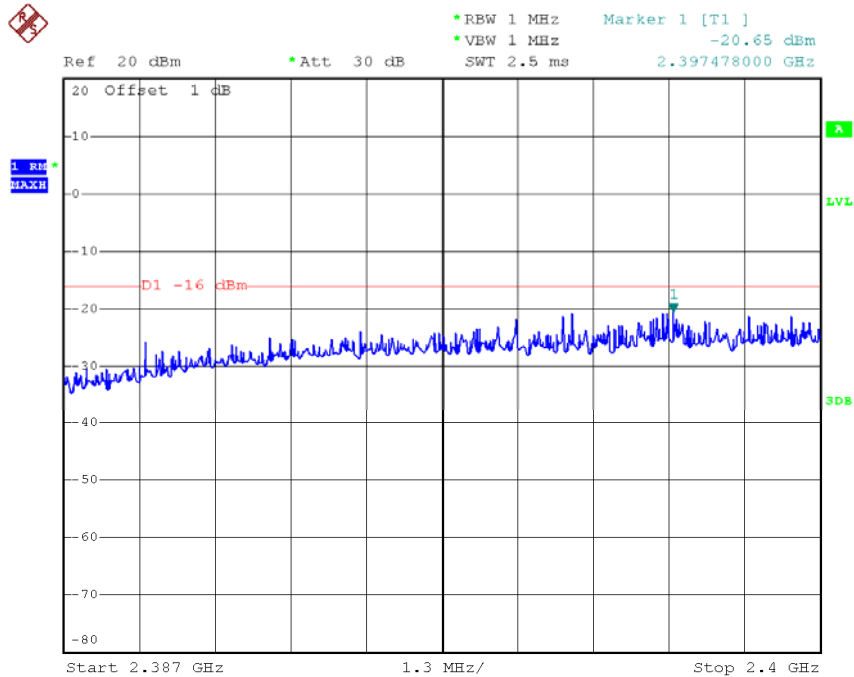

Date: 14.NOV.2015 13:22:22

High Voltage CH01 Frequency Band 4 (2483.5 MHz \cong f < 2496.5 MHz)

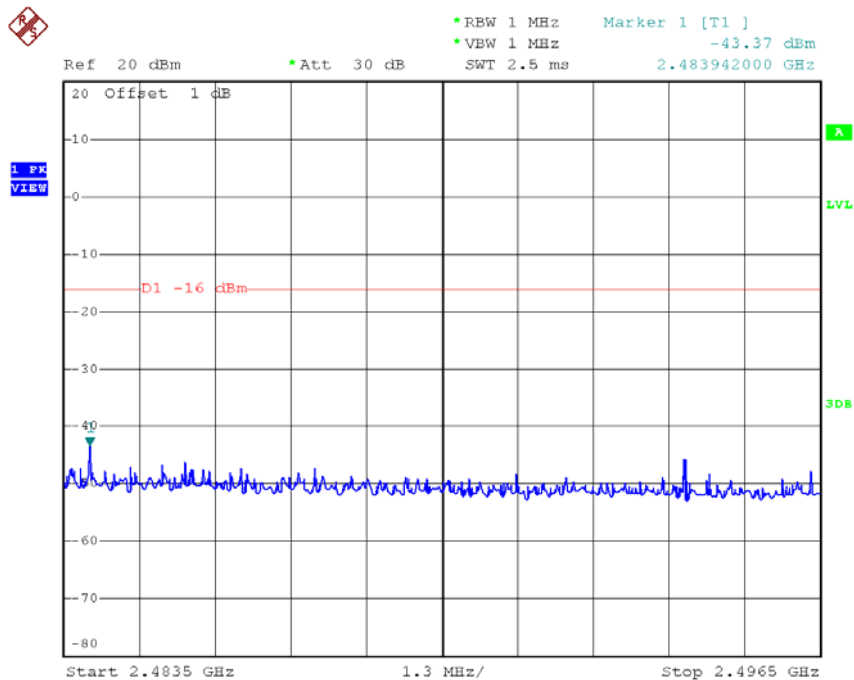

Date: 14.NOV.2015 12:59:45

High Voltage CH01 Frequency Band 5 (2496.5 MHz \leq f < 12.5 GHz)

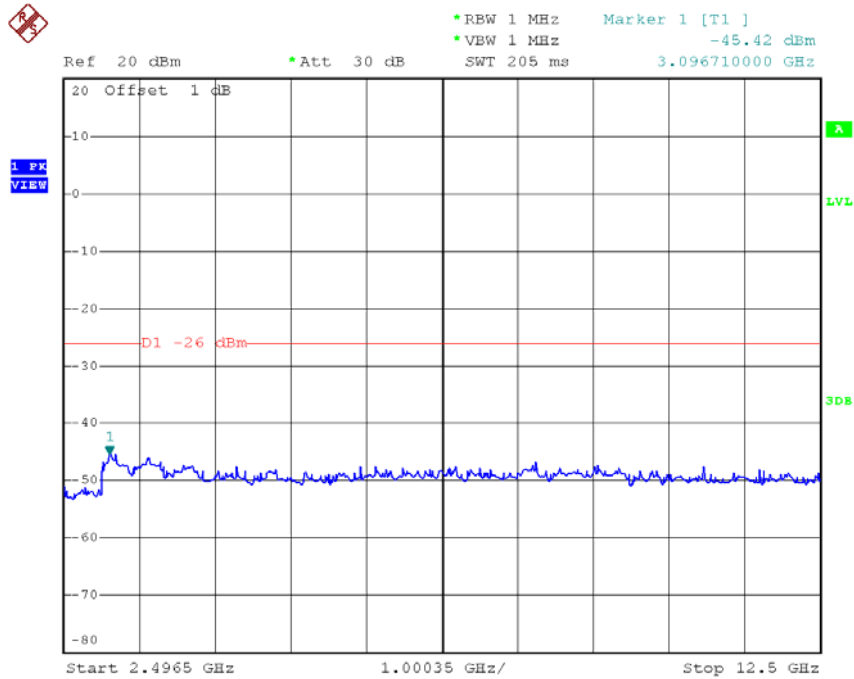

Date: 14.NOV.2015 12:59:55

High Voltage CH07 Frequency Band 1 (30 MHz \leq f \leq 1000 MHz)

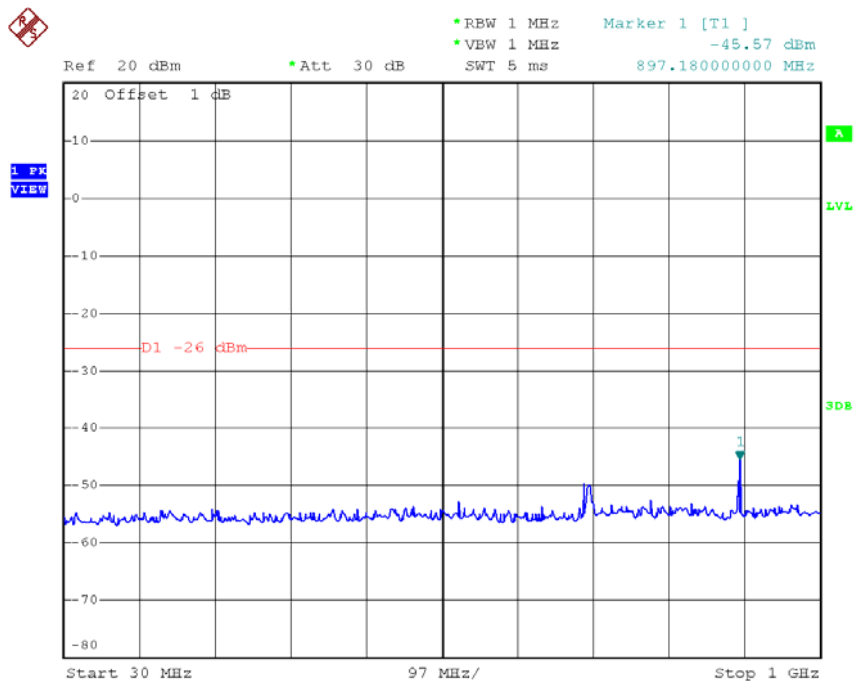

Date: 14.NOV.2015 13:27:05

High Voltage

CH07 Frequency Band 2 (1000 MHz $f \leq 2387 \text{ MHz}$)

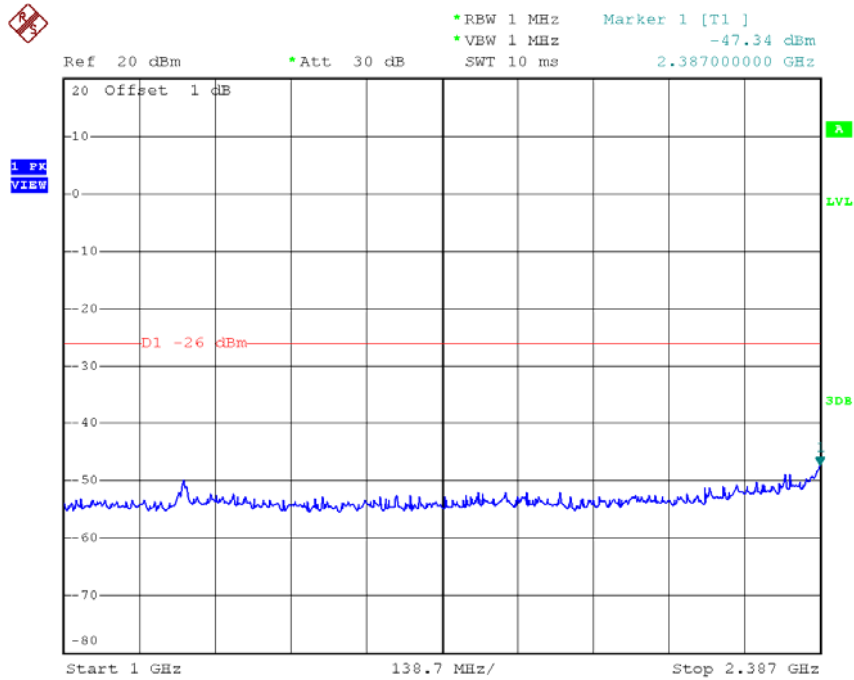

Date: 14.NOV.2015 13:27:17

High Voltage

CH07 Frequency Band 3 (2387 MHz $\leq f < 2400 \text{ MHz}$)

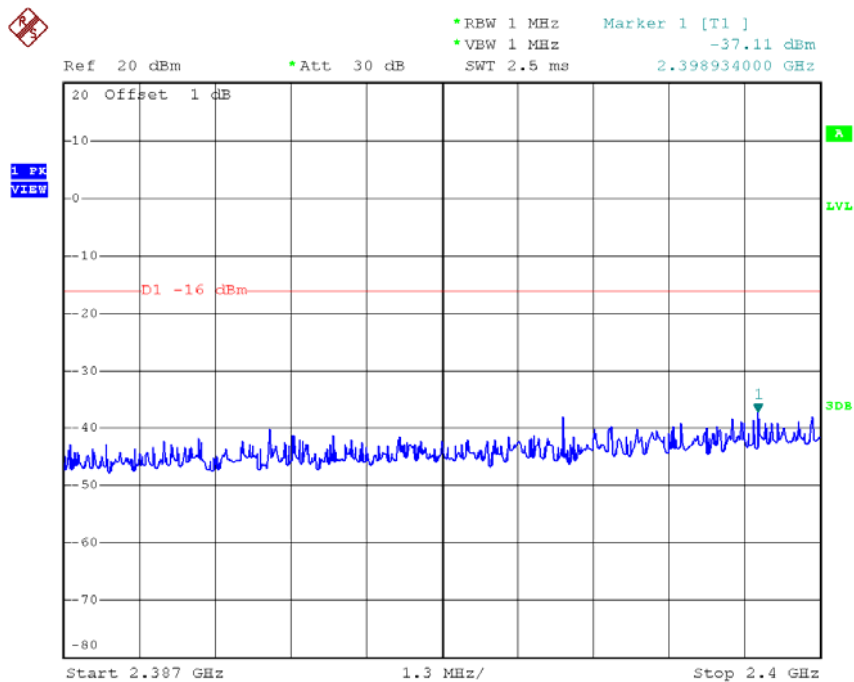

Date: 14.NOV.2015 13:27:28

High Voltage

CH07 Frequency Band 4 ($2483.5 \text{ MHz} \leq f < 2496.5 \text{ MHz}$)

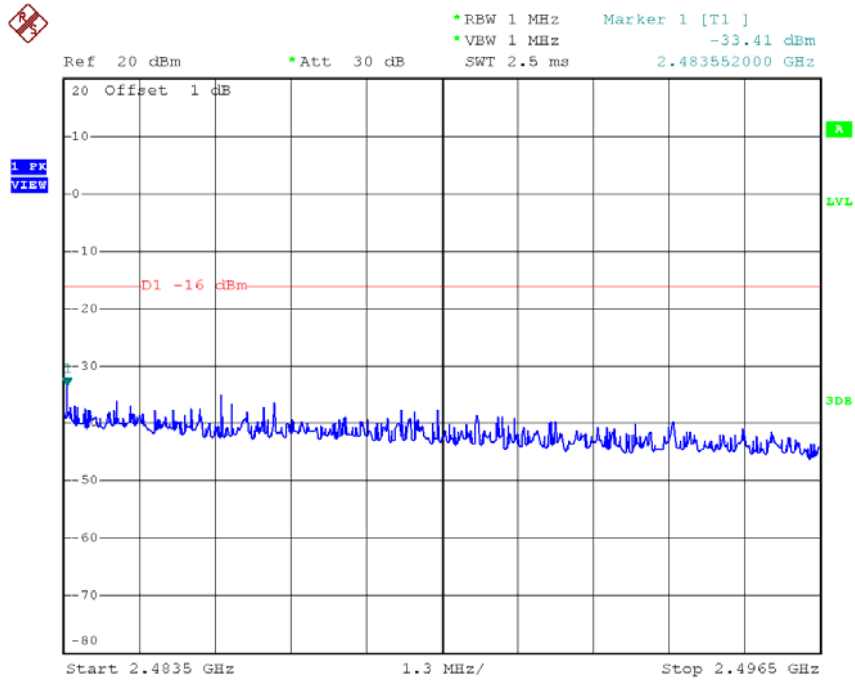

Date: 14.NOV.2015 13:27:37

High Voltage

CH07 Frequency Band 5 ($2496.5 \text{ MHz} \leq f < 12.5 \text{ GHz}$)

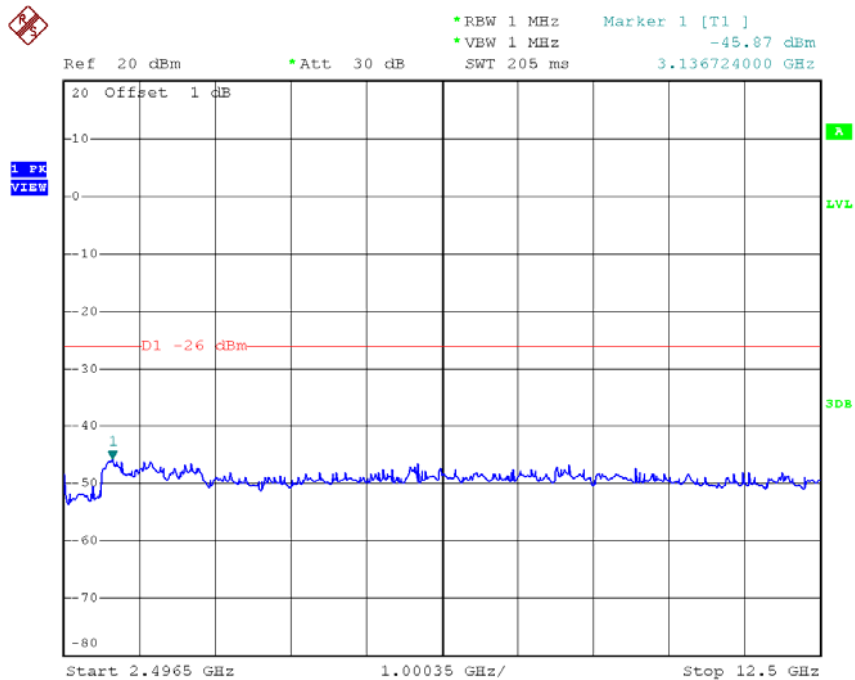

Date: 14.NOV.2015 13:27:48

High Voltage CH13 Frequency Band 1 (30 MHz \leq f \leq 1000 MHz)

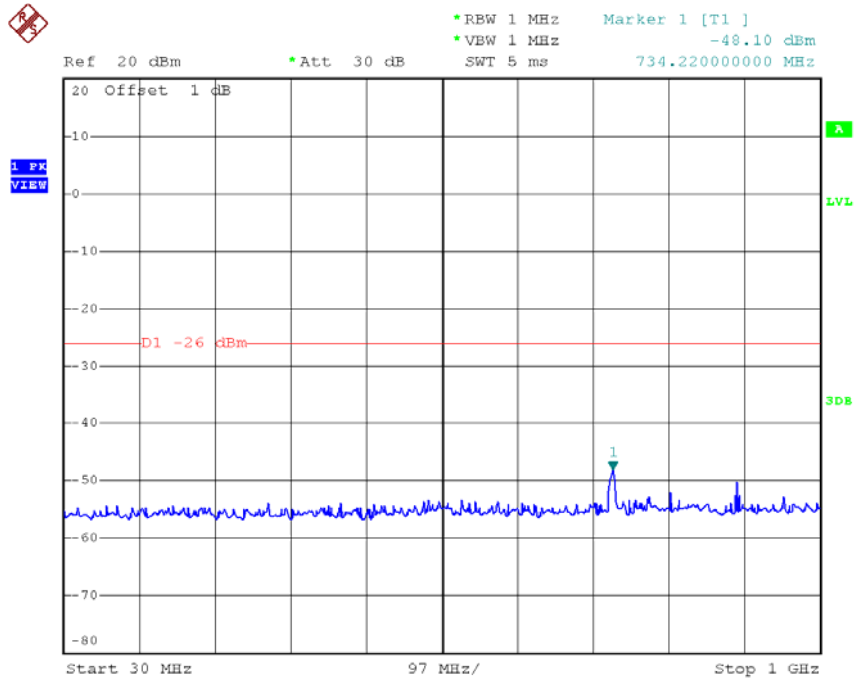

Date: 14.NOV.2015 13:42:28

High Voltage CH13 Frequency Band 2 (1000 MHz < f \leq 2387 MHz)

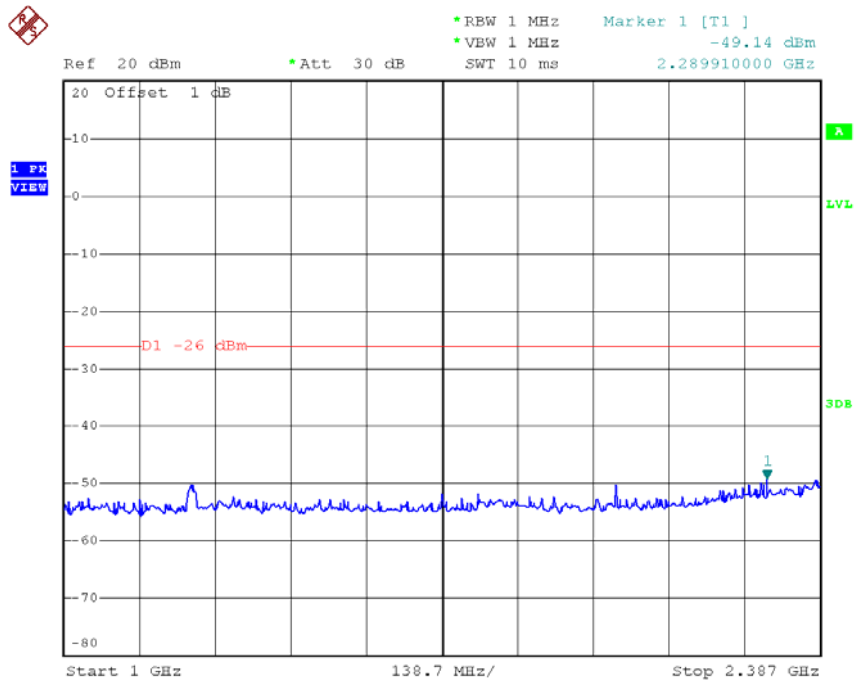

Date: 14.NOV.2015 13:42:40

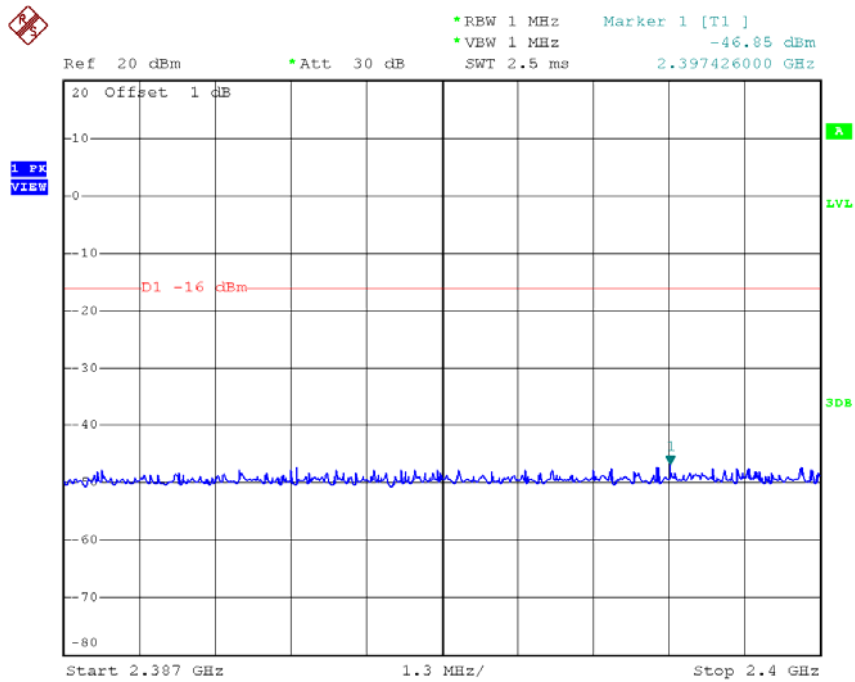
High Voltage**CH13 Frequency Band 3 (2387 MHz \leq f < 2400 MHz)**

Date: 14.NOV.2015 13:42:51

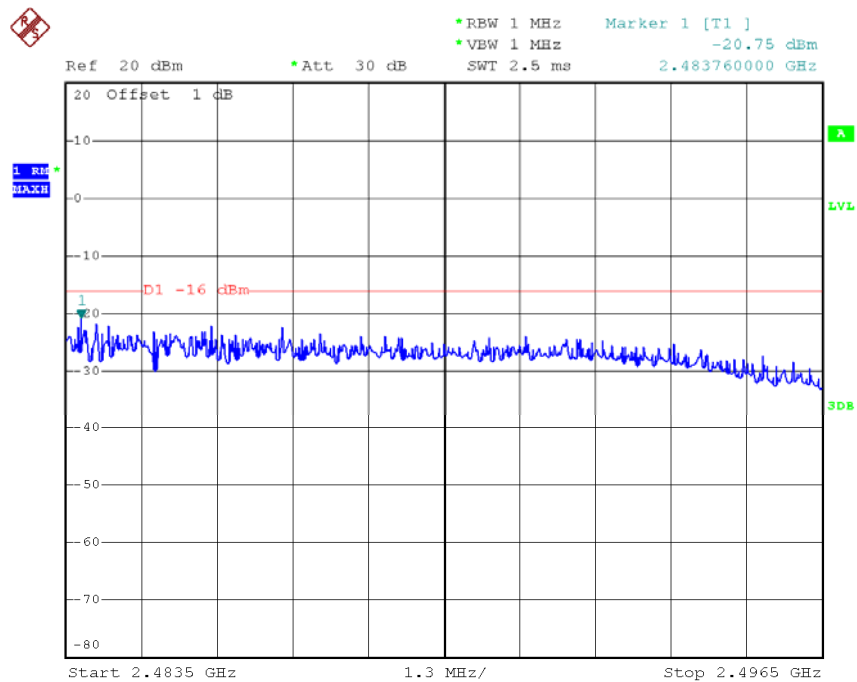
High Voltage**CH13 Frequency Band 4 (2483.5 MHz \leq f < 2496.5 MHz)**

Date: 14.NOV.2015 14:03:49

High Voltage

CH13 Frequency Band 5 (2496.5 MHz \cong f <12.5 GHz)

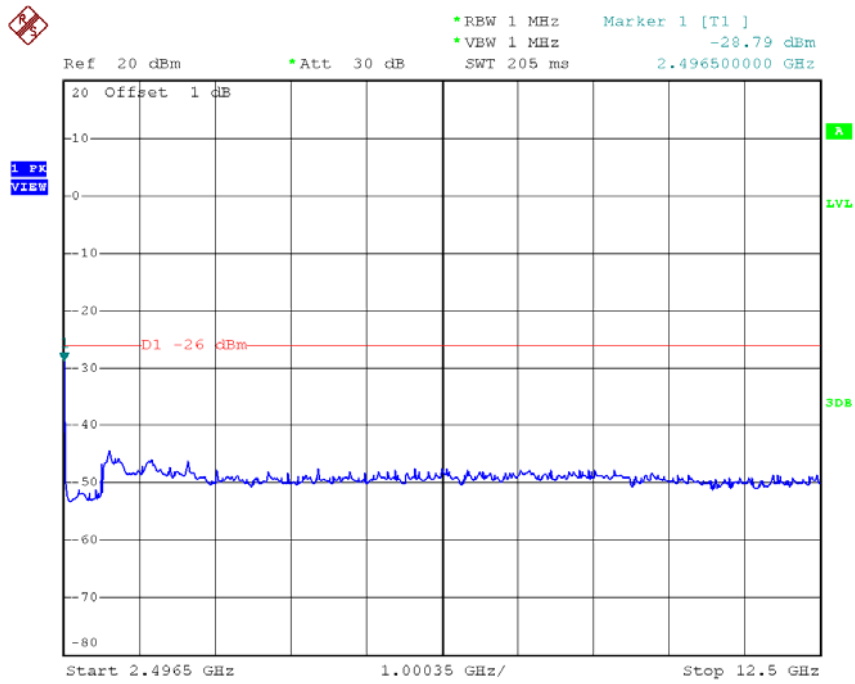

Date: 14.NOV.2015 13:43:11

Low Voltage CH01 Frequency Band 3 (2387 MHz \cong f < 2400 MHz)

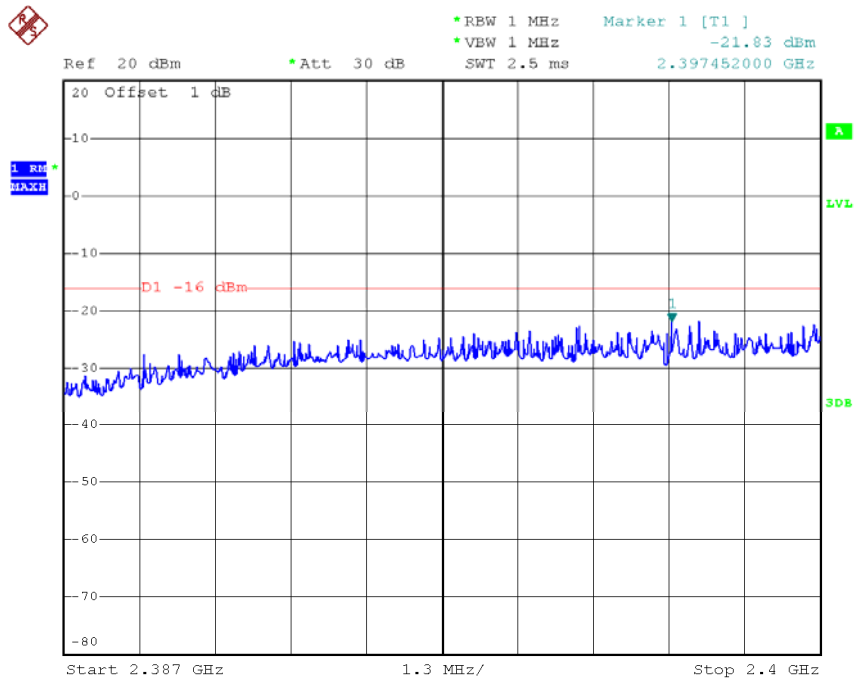

Date: 14.NOV.2015 13:22:57

Low Voltage CH01 Frequency Band 4 (2483.5 MHz \cong f < 2496.5 MHz)

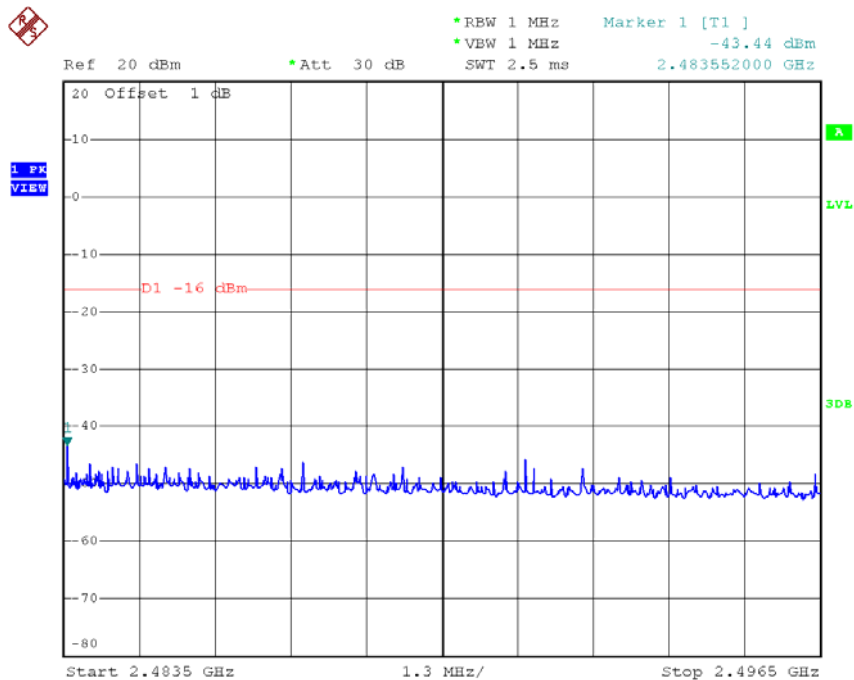

Date: 14.NOV.2015 13:14:35

Low Voltage CH01 Frequency Band 5 (2496.5 MHz \leq f < 12.5 GHz)

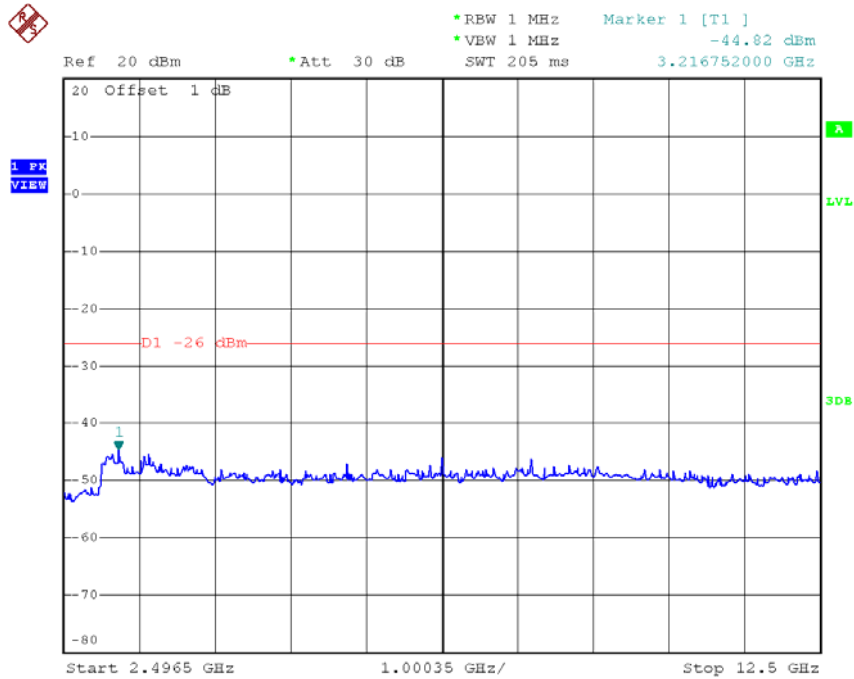

Date: 14.NOV.2015 13:14:46

Low Voltage CH07 Frequency Band 1 (30 MHz \leq f \leq 1000 MHz)

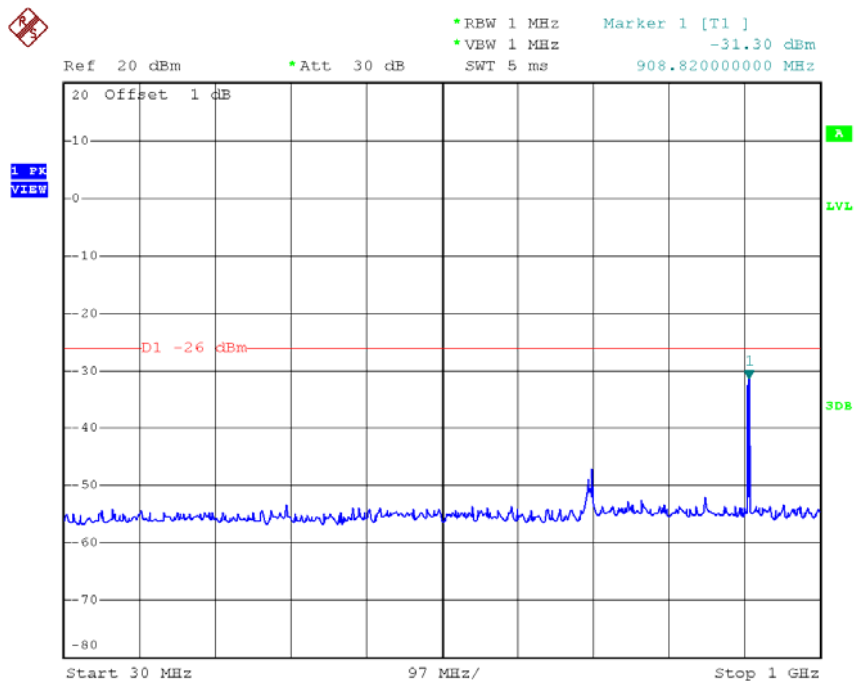

Date: 14.NOV.2015 13:34:00

Low Voltage

CH07 Frequency Band 2 (1000 MHz < f ≤ 2387 MHz)

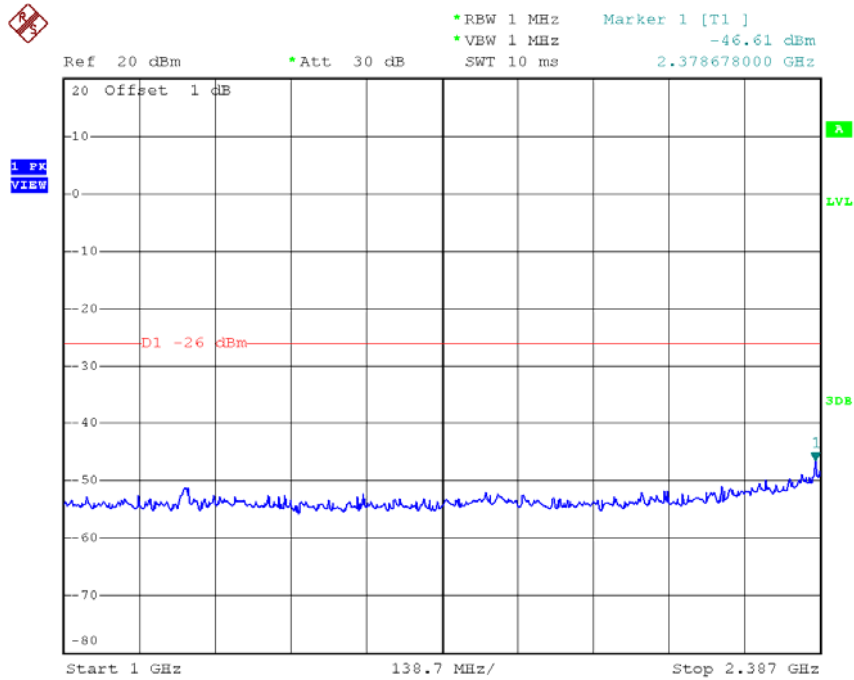

Date: 14.NOV.2015 13:34:11

Low Voltage

CH07 Frequency Band 3 (2387 MHz ≤ f < 2400 MHz)

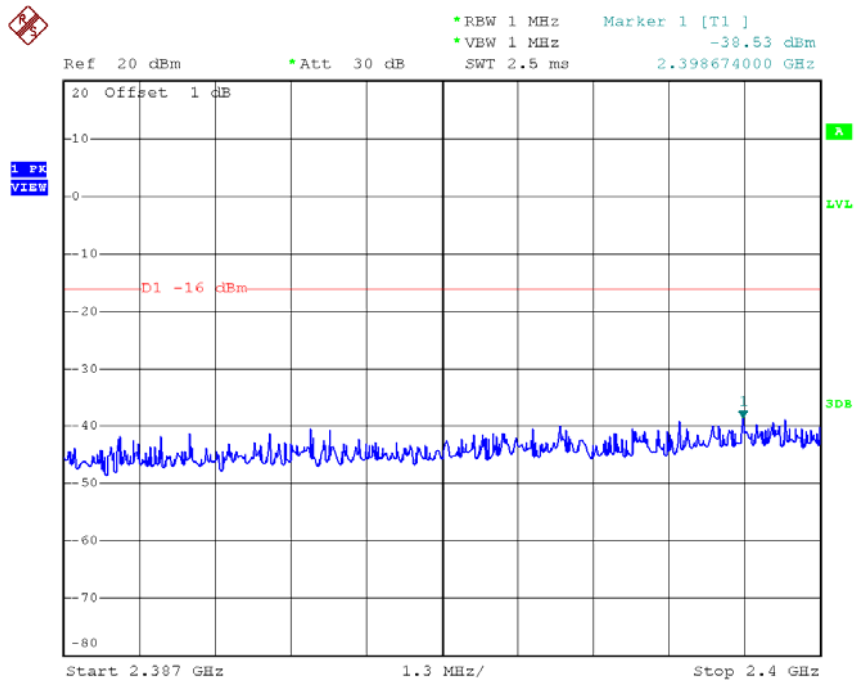

Date: 14.NOV.2015 13:34:22

Low Voltage

CH07 Frequency Band 4 ($2483.5 \text{ MHz} \leq f < 2496.5 \text{ MHz}$)

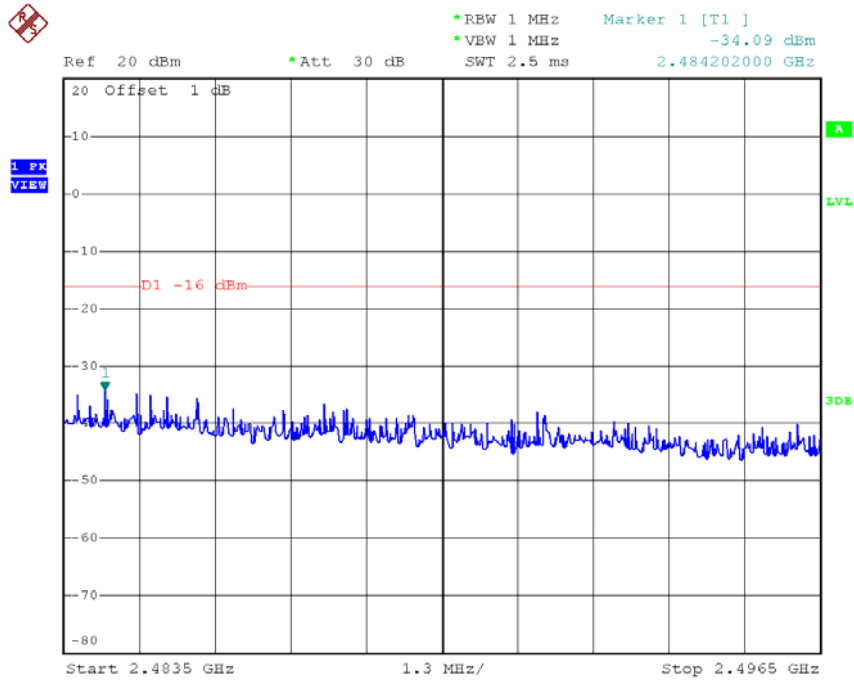

Date: 14.NOV.2015 13:34:32

Low Voltage

CH07 Frequency Band 5 ($2496.5 \text{ MHz} \leq f < 12.5 \text{ GHz}$)

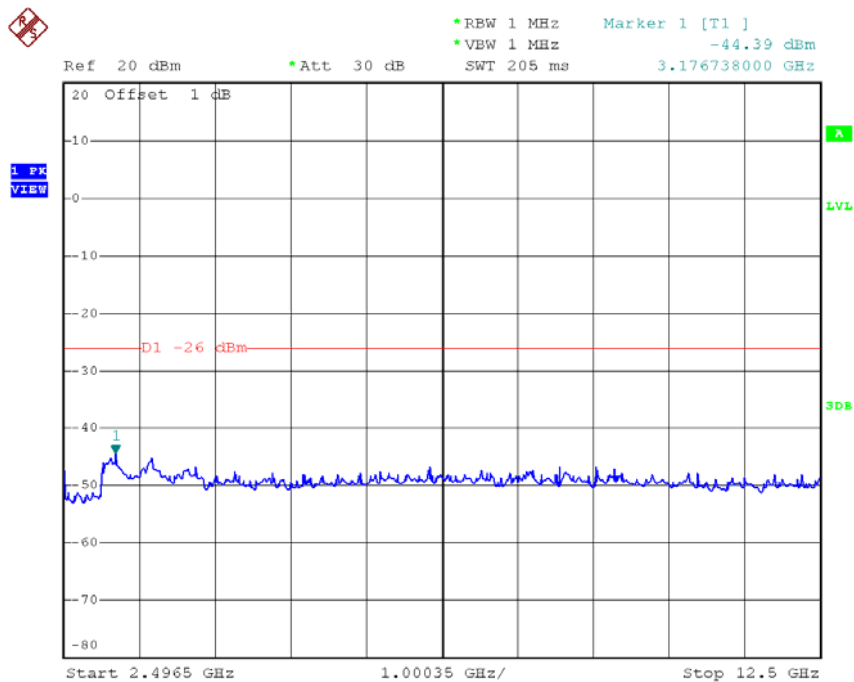

Date: 14.NOV.2015 13:34:43

Low Voltage

CH13 Frequency Band 1 (30 MHz \leq f \leq 1000 MHz)

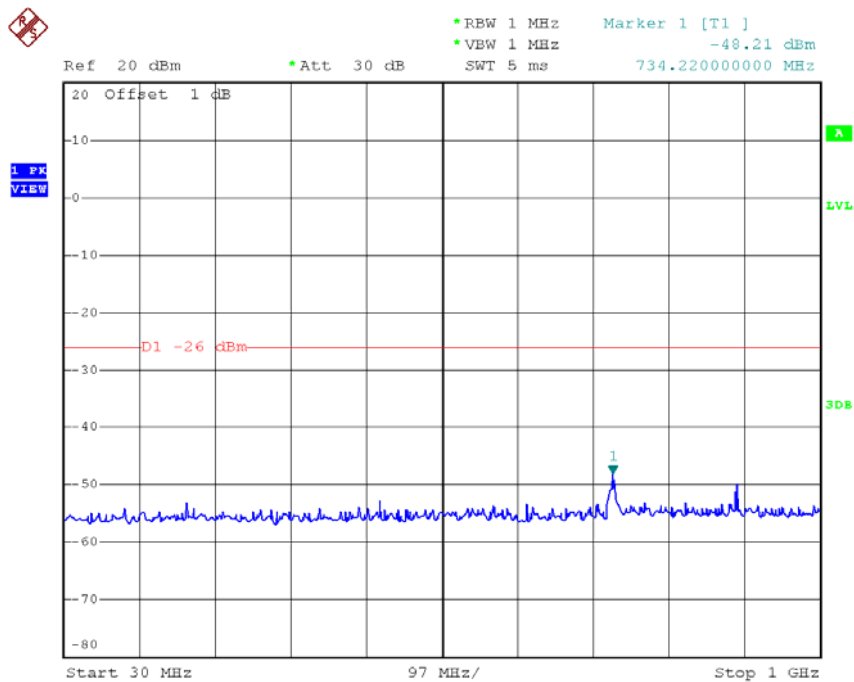

Date: 14.NOV.2015 13:57:54

Low Voltage

CH13 Frequency Band 2 (1000 MHz < f \leq 2387 MHz)

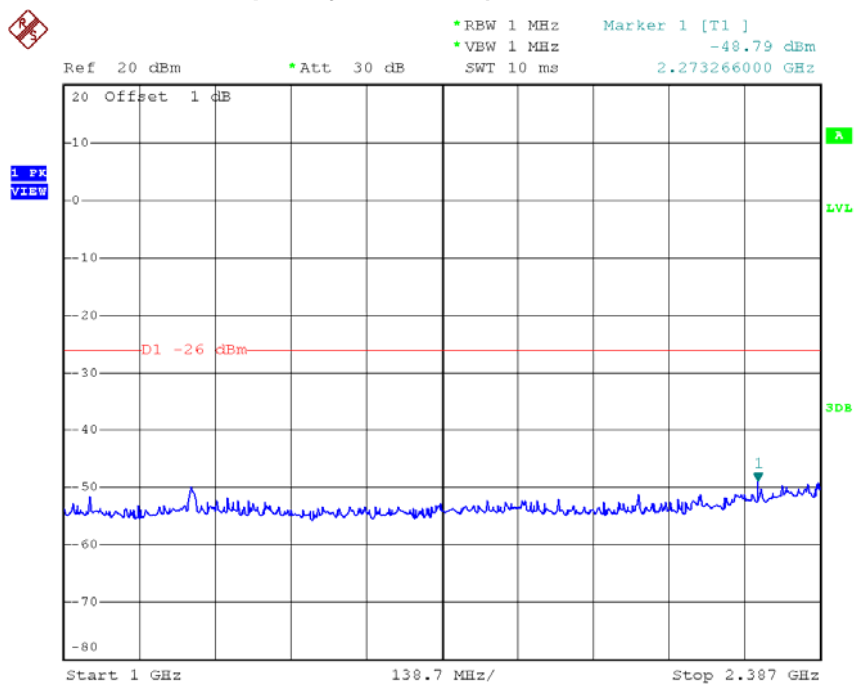

Date: 14.NOV.2015 13:58:05

Low Voltage

CH13 Frequency Band 3 (2387 MHz \leq f < 2400 MHz)

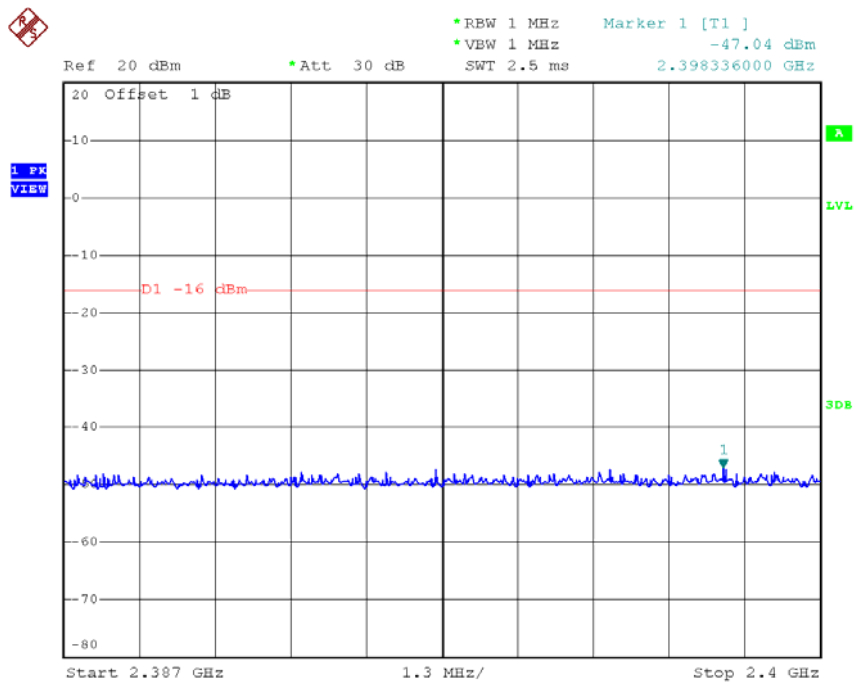

Date: 14.NOV.2015 13:58:16

Low Voltage

CH13 Frequency Band 4 (2483.5 MHz \leq f < 2496.5 MHz)

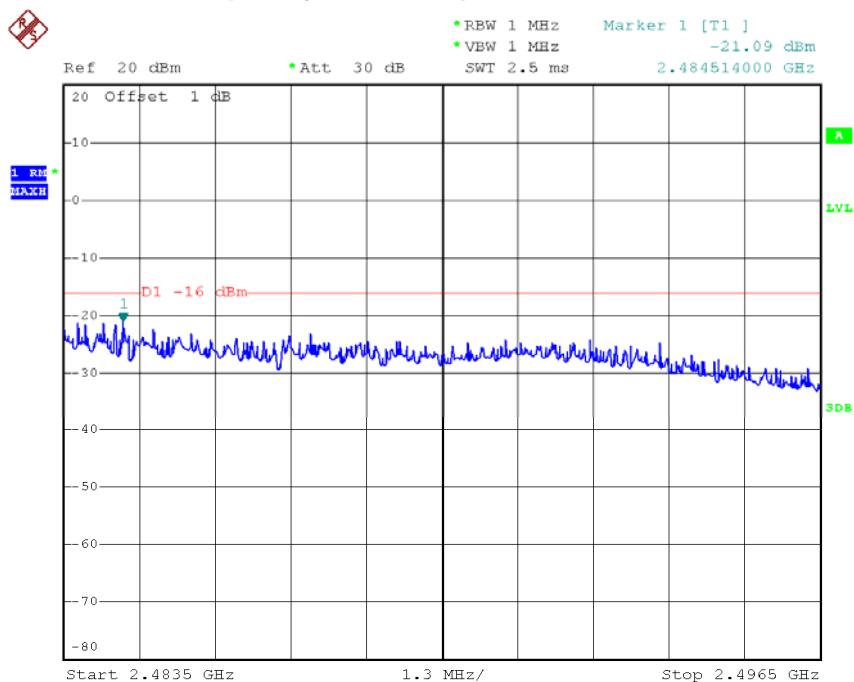

Date: 14.NOV.2015 14:05:25

Low Voltage

CH13 Frequency Band 5 (2496.5 MHz \cong f < 12.5 GHz)

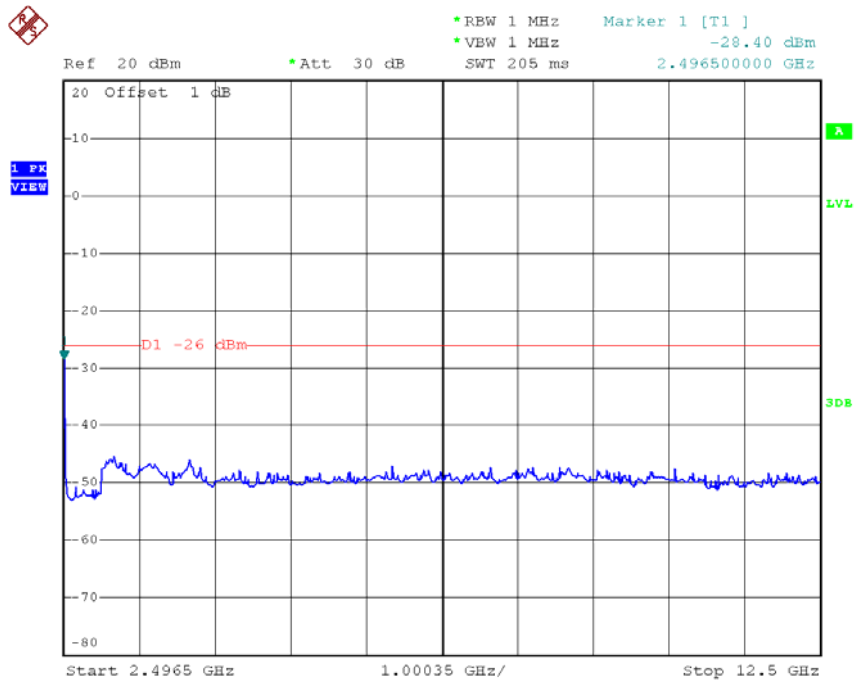

Date: 14.NOV.2015 13:58:37

ATTACHMENT D - ANTENNA POWER ERROR

For Chip antenna

Test Mode:	802.11b/CH01,CH07,CH13
------------	------------------------

Test Voltage (V)	Normal Voltage			Remarks
Test Frequency (MHz)	2412	2442	2472	Low/Mid/High of test frequency range
Antenna Power (mW/MHz)	6.26299	6.61884	6.20557	-
Antenna Power Error (mW/MHz)	-0.03701	0.31884	-0.09443	-
Antenna Power Error (%)	-0.59	5.06	-1.50	Limit + 20% ~ - 80%

Test Voltage (V)	High Voltage			Remarks
Test Frequency (MHz)	2412	2442	2472	Low/Mid/High of test frequency range
Antenna Power (mW/MHz)	6.20557	6.66472	6.29190	-
Antenna Power Error (mW/MHz)	-0.09443	0.36472	-0.00810	-
Antenna Power Error (%)	-1.50	5.79	-0.13	Limit + 20% ~ - 80%

Test Voltage (V)	Low Voltage			Remarks
Test Frequency (MHz)	2412	2442	2472	Low/Mid/High of test frequency range
Antenna Power (mW/MHz)	6.32094	6.75744	6.24859	-
Antenna Power Error (mW/MHz)	0.02094	0.45744	-0.05141	-
Antenna Power Error (%)	0.33	7.26	-0.82	Limit + 20% ~ - 80%

Test Mode:	802.11g/CH01,CH07,CH13
------------	------------------------

Test Voltage (V)	Normal Voltage			Remarks
Test Frequency (MHz)	2412	2442	2472	Low/Mid/High of test frequency range
Antenna Power (mW/MHz)	1.98053	4.31303	1.86115	-
Antenna Power Error (mW/MHz)	-2.01947	0.31303	-2.13885	-
Antenna Power Error (%)	-50.49	7.83	-53.47	Limit + 20% ~ - 80%

Test Voltage (V)	High Voltage			Remarks
Test Frequency (MHz)	2412	2442	2472	Low/Mid/High of test frequency range
Antenna Power (mW/MHz)	2.42539	4.30311	2.30029	-
Antenna Power Error (mW/MHz)	-1.57461	0.30311	-1.69971	-
Antenna Power Error (%)	-39.37	7.58	-42.49	Limit + 20% ~ - 80%

Test Voltage (V)	Low Voltage			Remarks
Test Frequency (MHz)	2412	2442	2472	Low/Mid/High of test frequency range
Antenna Power (mW/MHz)	2.38661	4.38311	1.97598	-
Antenna Power Error (mW/MHz)	-1.61339	0.38311	-2.02402	-
Antenna Power Error (%)	-40.33	9.58	-50.60	Limit + 20% ~ - 80%

Test Mode:	802.11n(HT20)/CH01,CH07,CH13
------------	------------------------------

Test Voltage (V)	Normal Voltage			Remarks
Test Frequency (MHz)	2412	2442	2472	Low/Mid/High of test frequency range
Antenna Power (mW/MHz)	2.39211	1.95336	2.20690	-
Antenna Power Error (mW/MHz)	-0.10789	-0.54664	-0.29310	-
Antenna Power Error (%)	-4.32	-21.87	-11.72	Limit + 20% ~ - 80%

Test Voltage (V)	High Voltage			Remarks
Test Frequency (MHz)	2412	2442	2472	Low/Mid/High of test frequency range
Antenna Power (mW/MHz)	2.17161	1.94887	2.00347	-
Antenna Power Error (mW/MHz)	-0.32839	-0.55113	-0.49653	-
Antenna Power Error (%)	-13.14	-22.05	-19.86	Limit + 20% ~ - 80%

Test Voltage (V)	Low Voltage			Remarks
Test Frequency (MHz)	2412	2442	2472	Low/Mid/High of test frequency range
Antenna Power (mW/MHz)	2.25830	1.85687	2.08825	-
Antenna Power Error (mW/MHz)	-0.24170	-0.64313	-0.41175	-
Antenna Power Error (%)	-9.67	-25.73	-16.47	Limit + 20% ~ - 80%

For Dipole antenna

Test Mode:	802.11b/CH01,CH07,CH13
------------	------------------------

Test Voltage (V)	Normal Voltage			Remarks
Test Frequency (MHz)	2412	2442	2472	Low/Mid/High of test frequency range
Antenna Power (mW/MHz)	9.30641	8.03123	9.11553	-
Antenna Power Error (mW/MHz)	1.10641	-0.16877	0.91553	-
Antenna Power Error (%)	13.49	-2.06	11.17	Limit + 20% ~ - 80%

Test Voltage (V)	High Voltage			Remarks
Test Frequency (MHz)	2412	2442	2472	Low/Mid/High of test frequency range
Antenna Power (mW/MHz)	9.30641	8.04974	8.99046	-
Antenna Power Error (mW/MHz)	1.10641	-0.15026	0.79046	-
Antenna Power Error (%)	13.49	-1.83	9.64	Limit + 20% ~ - 80%

Test Voltage (V)	Low Voltage			Remarks
Test Frequency (MHz)	2412	2442	2472	Low/Mid/High of test frequency range
Antenna Power (mW/MHz)	9.37091	8.04974	9.07365	-
Antenna Power Error (mW/MHz)	1.17091	-0.15026	0.87365	-
Antenna Power Error (%)	14.28	-1.83	10.65	Limit + 20% ~ - 80%

Test Mode:	802.11g/CH01,CH07,CH13
------------	------------------------

Test Voltage (V)	Normal Voltage			Remarks
Test Frequency (MHz)	2412	2442	2472	Low/Mid/High of test frequency range
Antenna Power (mW/MHz)	2.85616	2.53970	2.51063	-
Antenna Power Error (mW/MHz)	0.27616	-0.04030	-0.06937	-
Antenna Power Error (%)	10.70	-1.56	-2.69	Limit + 20% ~ - 80%

Test Voltage (V)	High Voltage			Remarks
Test Frequency (MHz)	2412	2442	2472	Low/Mid/High of test frequency range
Antenna Power (mW/MHz)	2.84303	2.53970	2.52803	-
Antenna Power Error (mW/MHz)	0.26303	-0.04030	-0.05197	-
Antenna Power Error (%)	10.20	-1.56	-2.01	Limit + 20% ~ - 80%

Test Voltage (V)	Low Voltage			Remarks
Test Frequency (MHz)	2412	2442	2472	Low/Mid/High of test frequency range
Antenna Power (mW/MHz)	2.83649	2.53386	2.49334	-
Antenna Power Error (mW/MHz)	0.25649	-0.04614	-0.08666	-
Antenna Power Error (%)	9.94	-1.79	-3.36	Limit + 20% ~ - 80%

Test Mode:	802.11n(HT20)/CH01,CH07,CH13
------------	------------------------------

Test Voltage (V)	Normal Voltage			Remarks
Test Frequency (MHz)	2412	2442	2472	Low/Mid/High of test frequency range
Antenna Power (mW/MHz)	1.48177	1.49893	1.54093	-
Antenna Power Error (mW/MHz)	-0.01823	-0.00107	0.04093	-
Antenna Power Error (%)	-1.22	-0.07	2.73	Limit + 20% ~ - 80%

Test Voltage (V)	High Voltage			Remarks
Test Frequency (MHz)	2412	2442	2472	Low/Mid/High of test frequency range
Antenna Power (mW/MHz)	1.53385	1.52329	1.53738	-
Antenna Power Error (mW/MHz)	0.03385	0.02329	0.03738	-
Antenna Power Error (%)	2.26	1.55	2.49	Limit + 20% ~ - 80%

Test Voltage (V)	Low Voltage			Remarks
Test Frequency (MHz)	2412	2442	2472	Low/Mid/High of test frequency range
Antenna Power (mW/MHz)	1.50932	1.51629	1.51280	-
Antenna Power Error (mW/MHz)	0.00932	0.01629	0.01280	-
Antenna Power Error (%)	0.62	1.09	0.85	Limit + 20% ~ - 80%

ATTACHMENT E - LIMITATION OF COLLATERAL EMISSION OF RECEIVER

For Chip antenna

Test Mode:	802.11b/CH01,CH07,CH13
------------	------------------------

Test Voltage		V	Normal Voltage			Remarks
Test Frequency		MHz	2412	2442	2472	Low/Mid/Low of test frequency range
Limitation of Collateral Emission of Receiver	※6	nW	0.0964	0.1483	0.0933	Limit ≅ 4 nW (-54 dBm)
	※7	nW	0.4613	0.5458	0.2799	Limit ≅ 20 nW (-47 dBm)

Test Voltage		V	High Voltage			Remarks
Test Frequency		MHz	2412	2442	2472	Low/Mid/Low of test frequency range
Limitation of Collateral Emission of Receiver	※6	nW	0.0624	0.0528	0.1117	Limit ≅ 4 nW (-54 dBm)
	※7	nW	0.2951	0.3846	0.0920	Limit ≅ 20 nW (-47 dBm)

Test Voltage		V	Low Voltage			Remarks
Test Frequency		MHz	2412	2442	2472	Low/Mid/Low of test frequency range
Limitation of Collateral Emission of Receiver	※6	nW	0.1079	0.1117	0.1211	Limit ≅ 4 nW (-54 dBm)
	※7	nW	0.0290	0.0327	0.0310	Limit ≅ 20 nW (-47 dBm)

Normal Voltage
CH01- Frequency Band 6 (30 MHz \leq f < 1000 MHz)

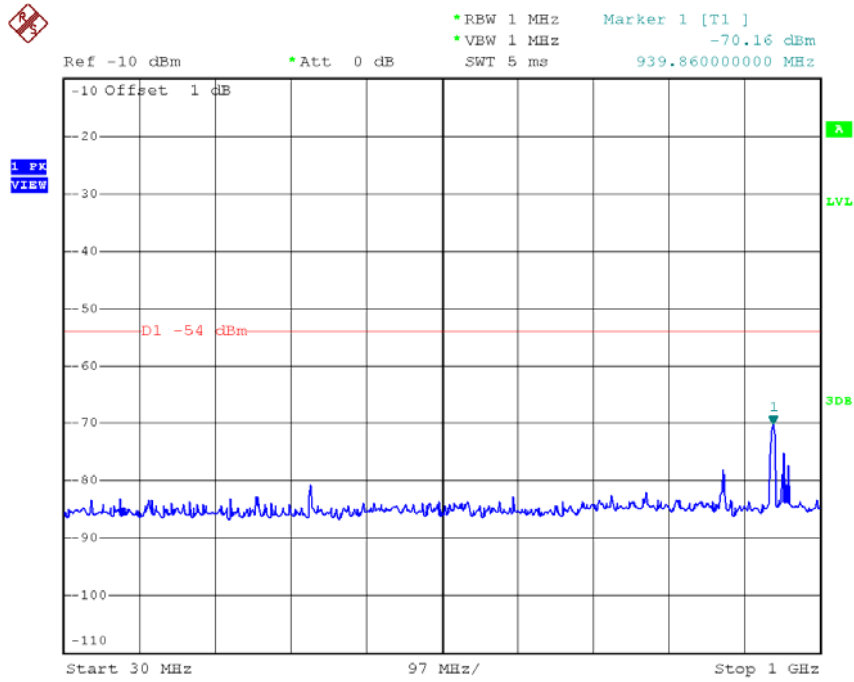

Date: 17.NOV.2015 18:15:20

Normal Voltage
CH01- Frequency Band 7 (1000 MHz \leq f < 12.5 GHz)

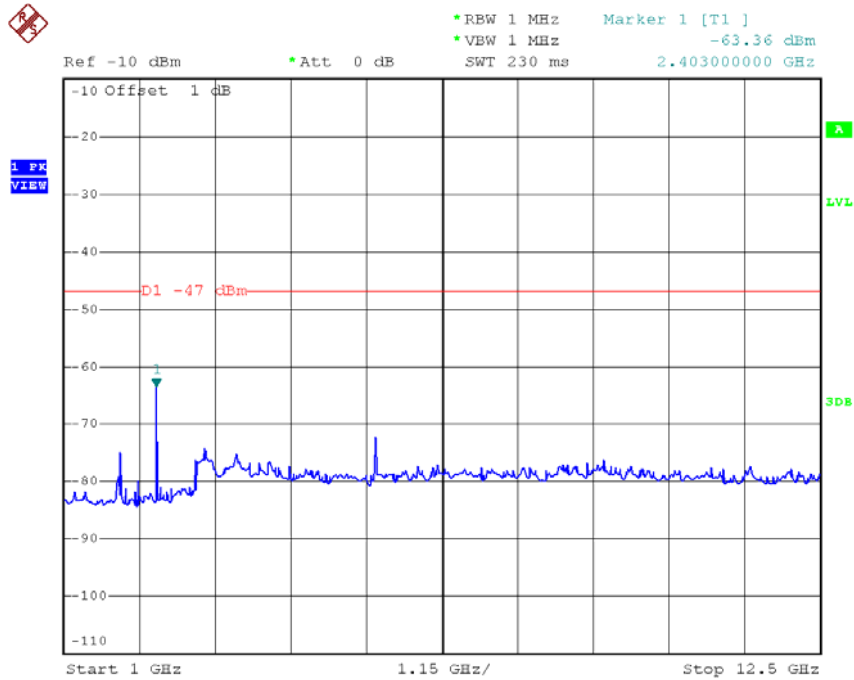

Date: 17.NOV.2015 18:15:31

Normal Voltage
CH07- Frequency Band 6 (30 MHz \cong f < 1000 MHz)

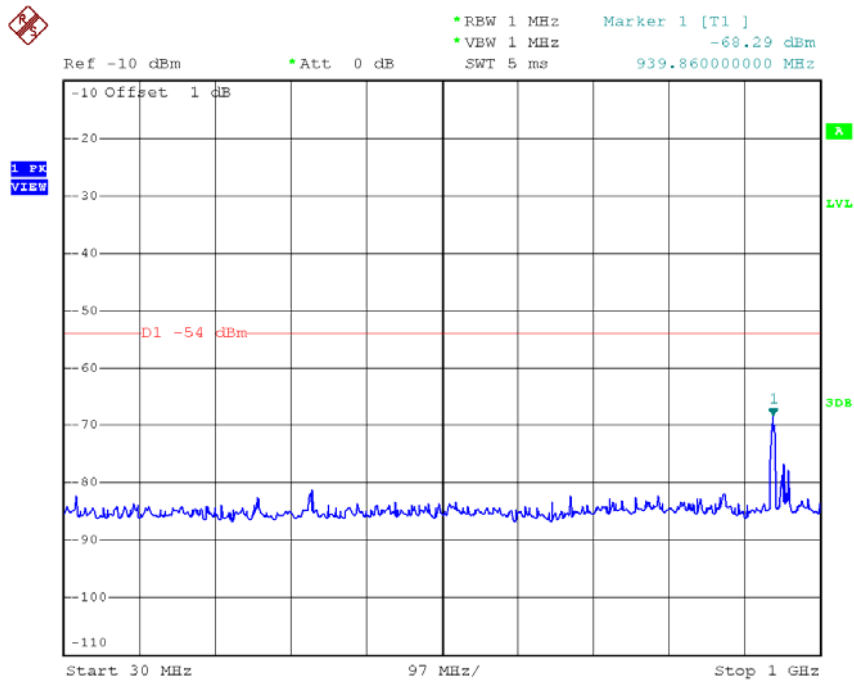

Date: 17.NOV.2015 18:15:43

Normal Voltage
CH07- Frequency Band 7 (1000 MHz \cong f < 12.5 GHz)

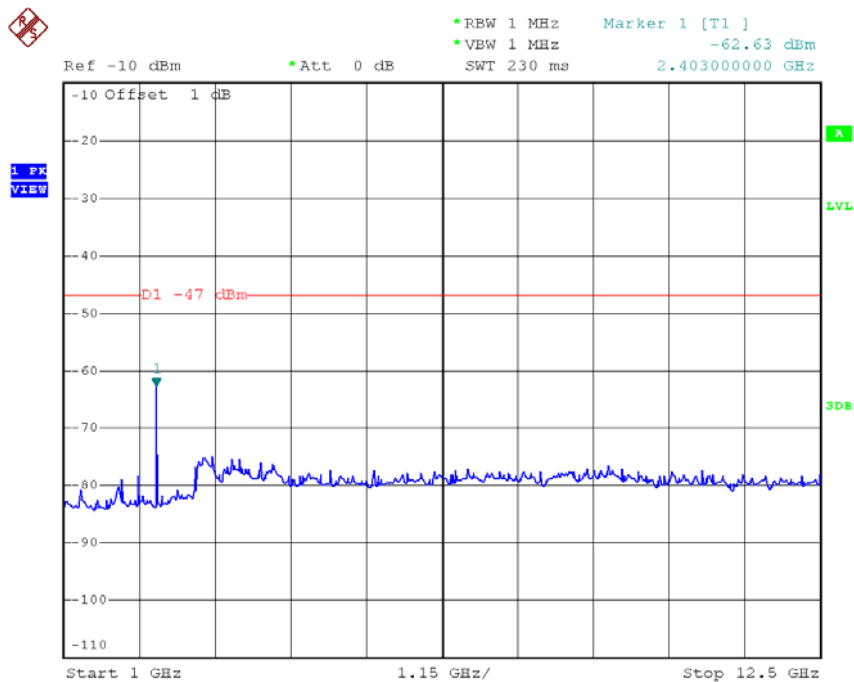

Date: 17.NOV.2015 18:15:54

Normal Voltage CH13- Frequency Band 6 (30 MHz \leq f < 1000 MHz)

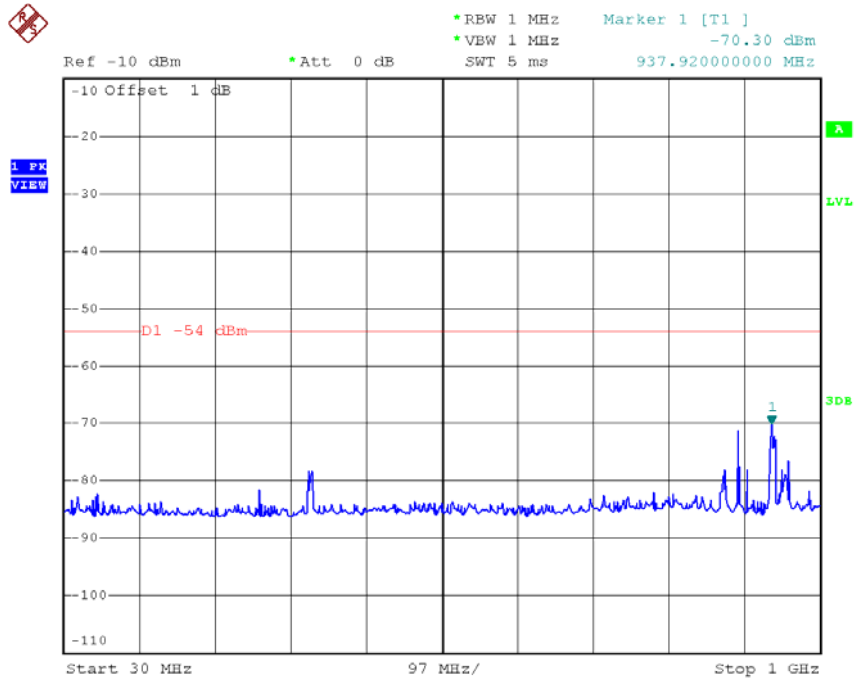

Date: 17.NOV.2015 18:28:43

Normal Voltage CH13- Frequency Band 7 (1000 MHz \leq f < 12.5 GHz)

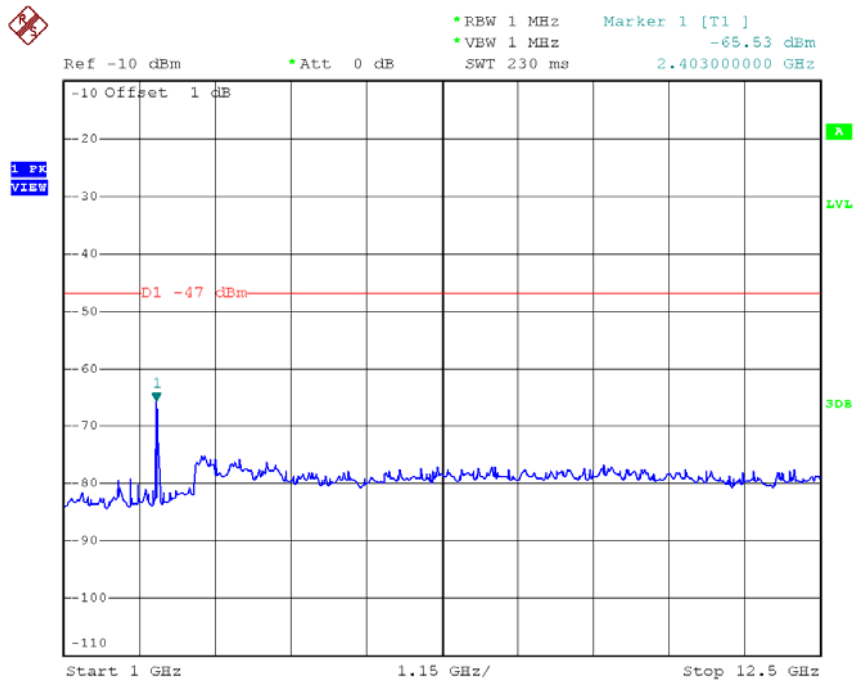

Date: 17.NOV.2015 18:17:10

High Voltage CH01- Frequency Band 6 (30 MHz \leq f < 1000 MHz)

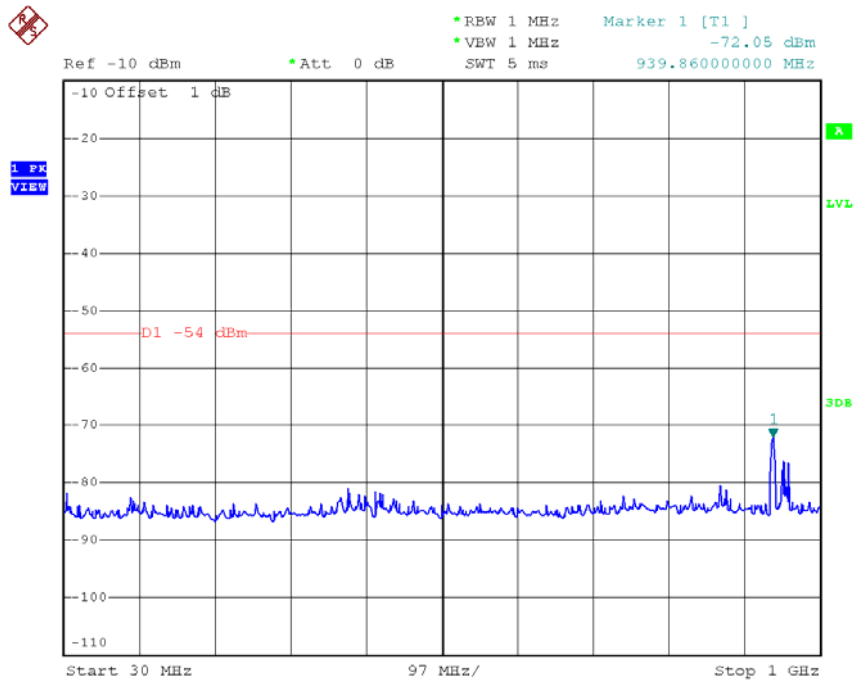

Date: 17.NOV.2015 18:10:39

High Voltage CH01- Frequency Band 7 (1000 MHz \leq f < 12.5 GHz)

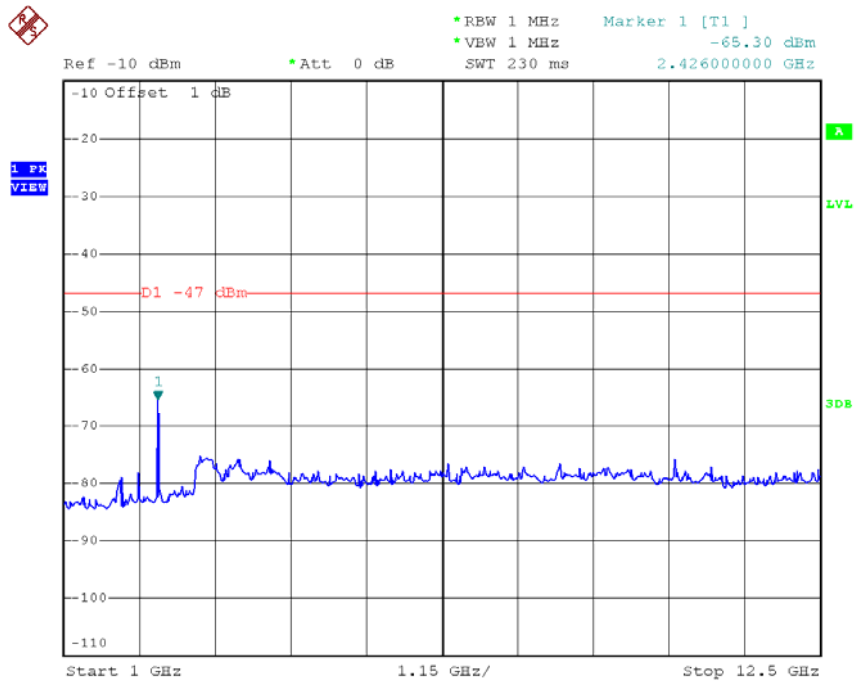

Date: 17.NOV.2015 18:10:50

High Voltage CH07- Frequency Band 6 (30 MHz \cong f < 1000 MHz)

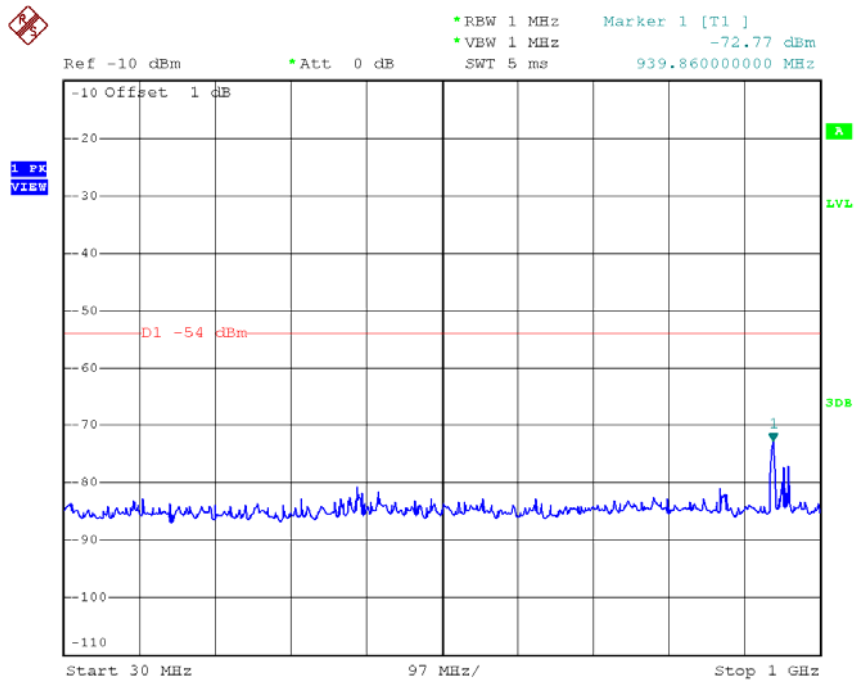

Date: 17.NOV.2015 18:11:03

High Voltage CH07- Frequency Band 7 (1000 MHz \cong f < 12.5 GHz)

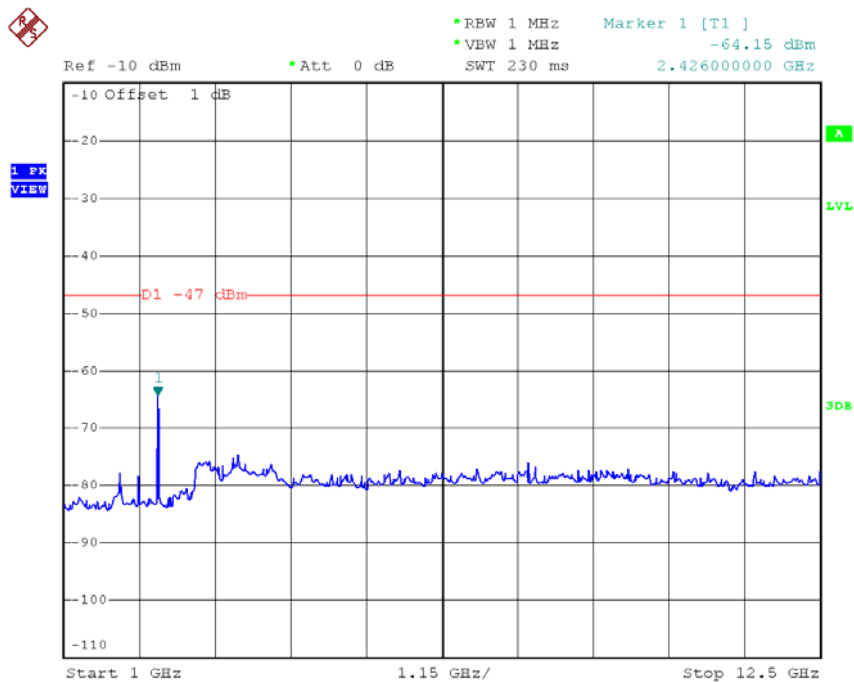

Date: 17.NOV.2015 18:11:14

High Voltage CH13- Frequency Band 6 (30 MHz \cong f < 1000 MHz)

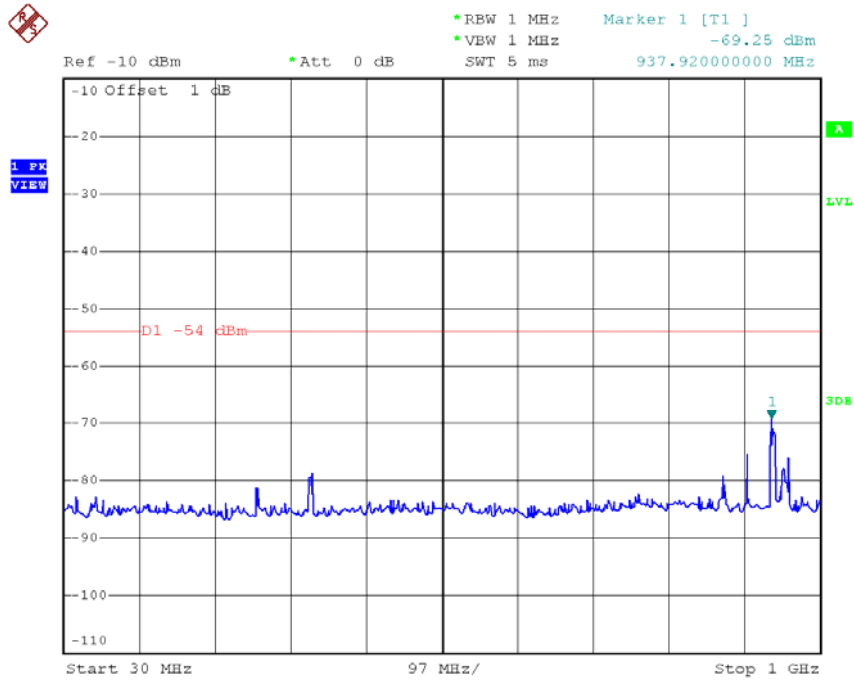

Date: 17.NOV.2015 18:28:12

High Voltage CH13- Frequency Band 7 (1000 MHz \cong f < 12.5 GHz)

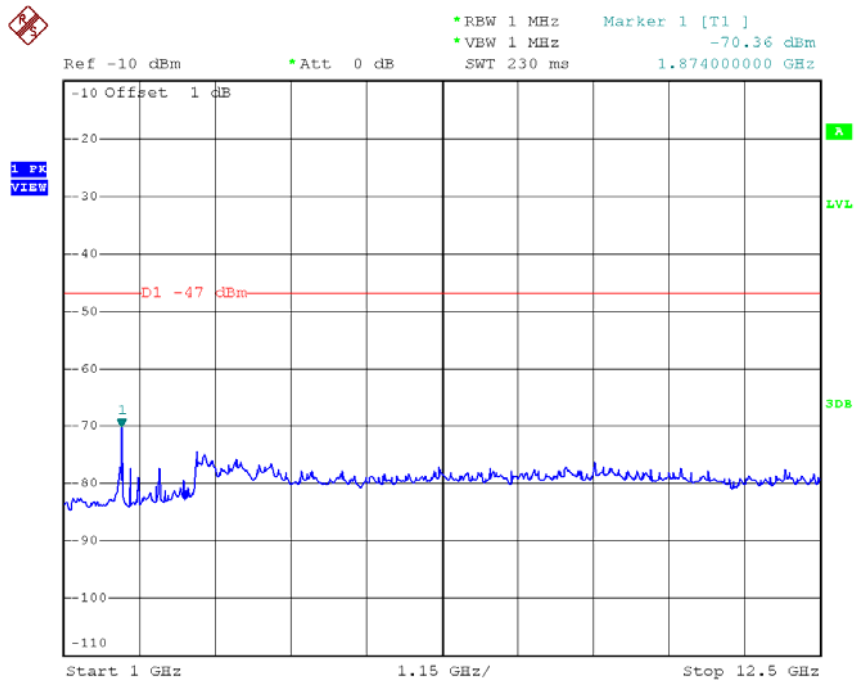

Date: 17.NOV.2015 18:11:39

Low Voltage

CH01- Frequency Band 6 ($30 \text{ MHz} \leq f < 1000 \text{ MHz}$)

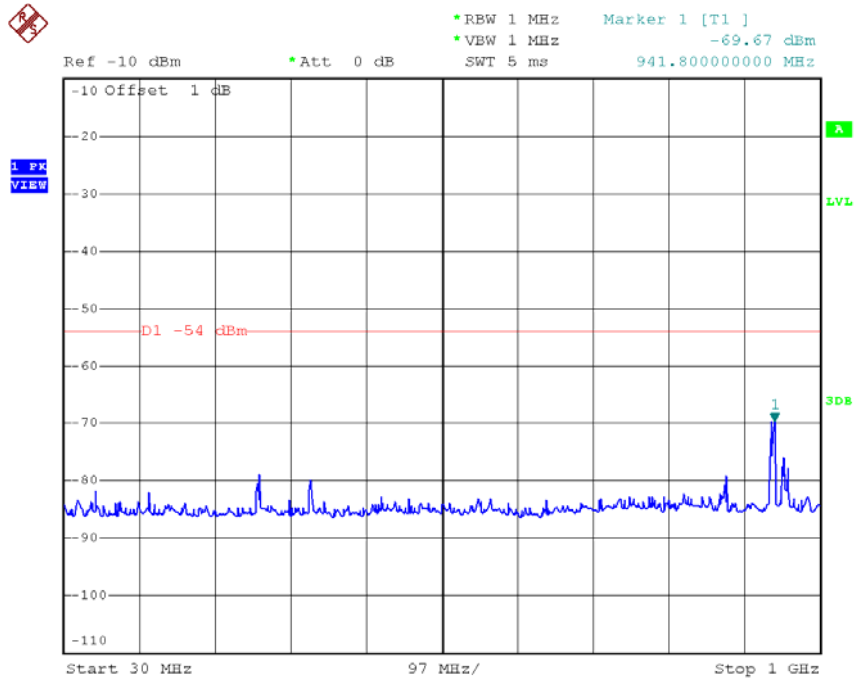

Date: 17.NOV.2015 18:22:54

Low Voltage

CH01- Frequency Band 7 ($1000 \text{ MHz} \leq f < 12.5 \text{ GHz}$)

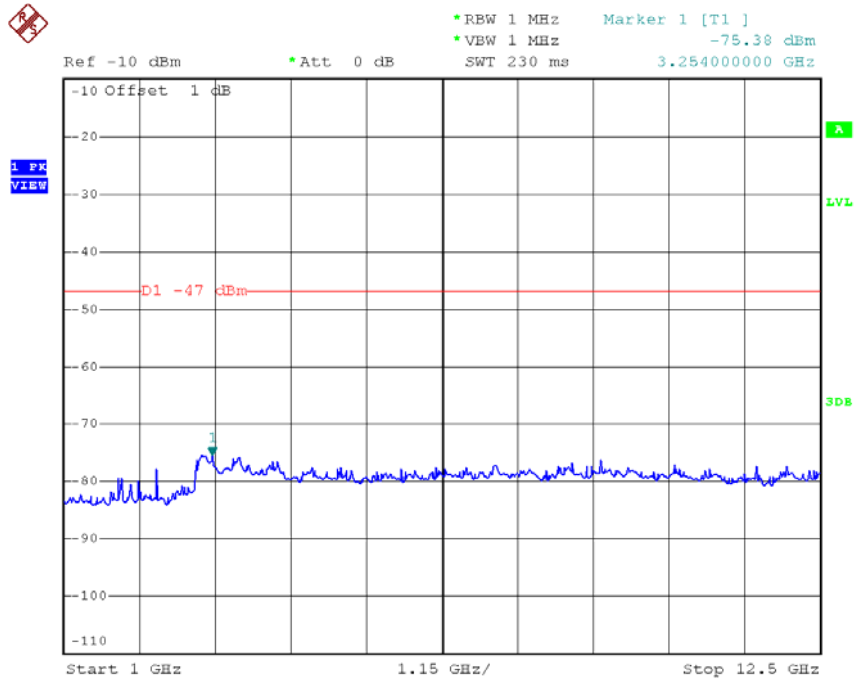

Date: 17.NOV.2015 18:23:05

Low Voltage CH07- Frequency Band 6 (30 MHz \leq f < 1000 MHz)

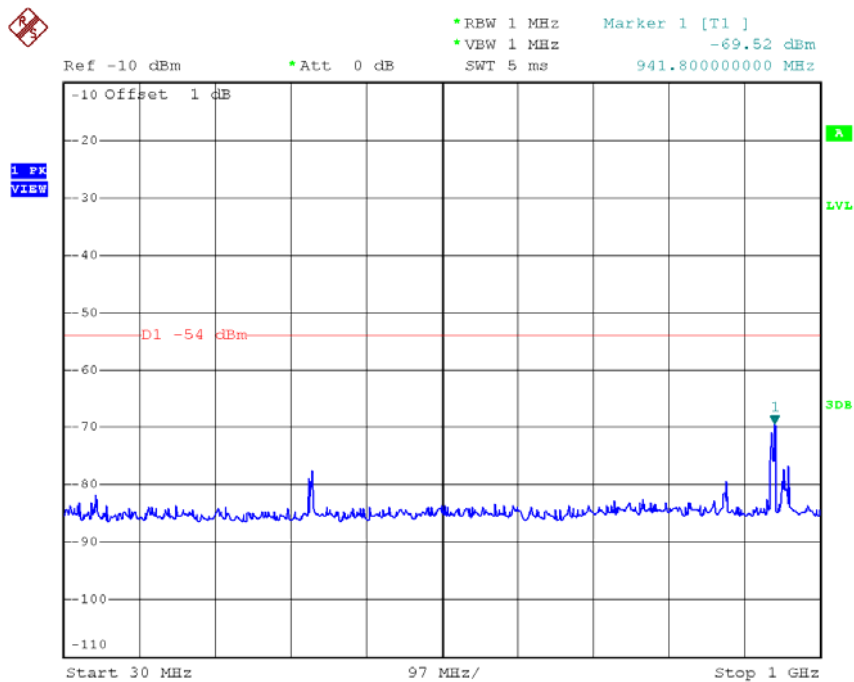

Date: 17.NOV.2015 18:23:16

Low Voltage CH07- Frequency Band 7 (1000 MHz \leq f < 12.5 GHz)

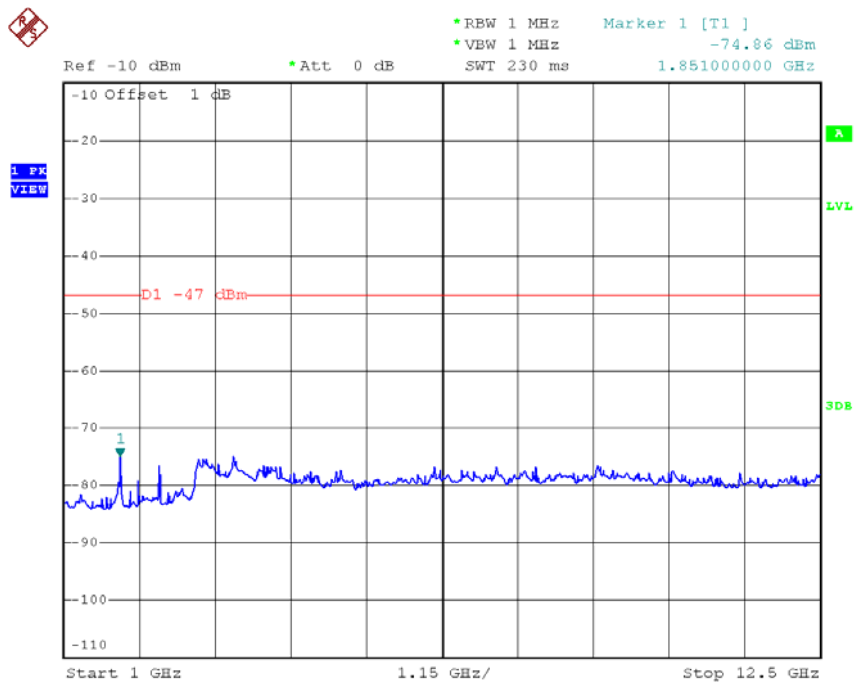

Date: 17.NOV.2015 18:23:27

Low Voltage CH13- Frequency Band 6 (30 MHz \cong f < 1000 MHz)

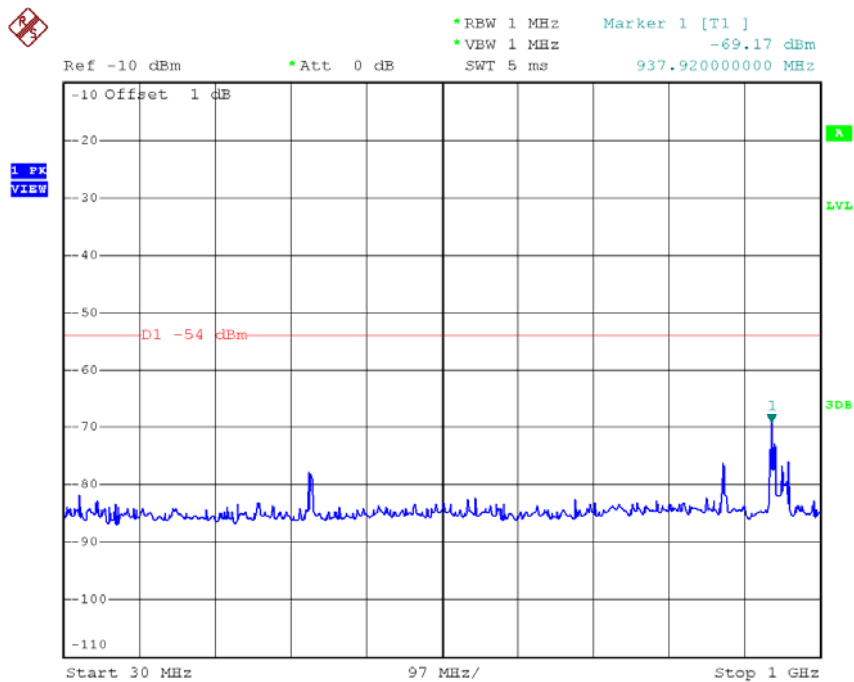

Date: 17.NOV.2015 18:29:07

Low Voltage CH13- Frequency Band 7 (1000 MHz \cong f < 12.5 GHz)

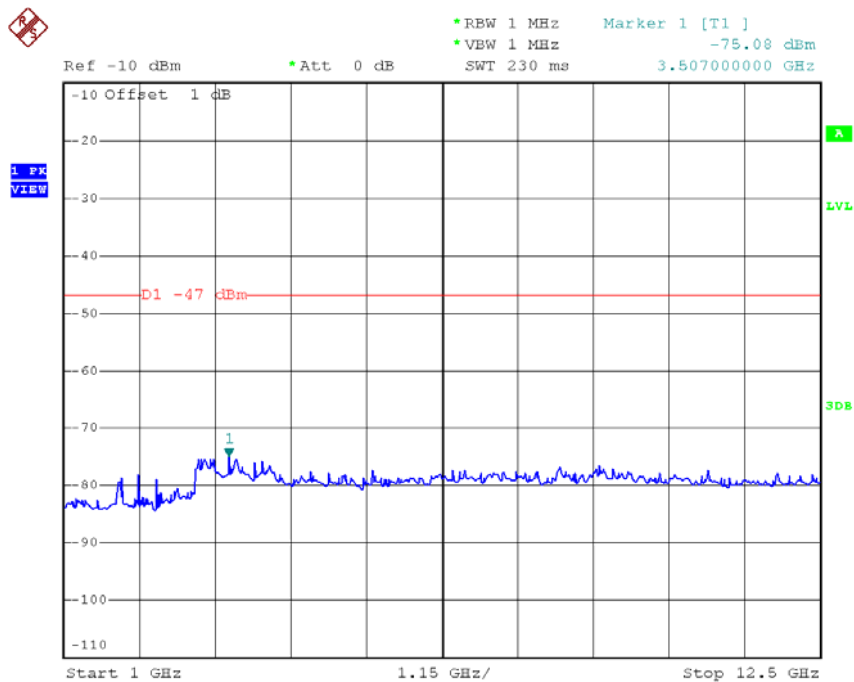

Date: 17.NOV.2015 18:23:49

Test Mode:	802.11g/CH01,CH07,CH13
------------	------------------------

Test Voltage		V	Normal Voltage			Remarks
Test Frequency		MHz	2412	2442	2472	Low/Mid/Low of test frequency range
Limitation of Collateral Emission of Receiver	※6	nW	0.1002	0.1028	0.1242	Limit \leq 4 nW (-54 dBm)
	※7	nW	1.5346	0.2723	0.3475	Limit \leq 20 nW (-47 dBm)

Test Voltage		V	High Voltage			Remarks
Test Frequency		MHz	2412	2442	2472	Low/Mid/Low of test frequency range
Limitation of Collateral Emission of Receiver	※6	nW	0.0710	0.0867	0.0822	Limit \leq 4 nW (-54 dBm)
	※7	nW	0.0314	0.0885	0.0332	Limit \leq 20 nW (-47 dBm)

Test Voltage		V	Low Voltage			Remarks
Test Frequency		MHz	2412	2442	2472	Low/Mid/Low of test frequency range
Limitation of Collateral Emission of Receiver	※6	nW	0.0818	0.0845	0.0822	Limit \leq 4 nW (-54 dBm)
	※7	nW	0.0366	0.0304	0.0307	Limit \leq 20 nW (-47 dBm)

Normal Voltage
CH01- Frequency Band 6 (30 MHz \leq f < 1000 MHz)

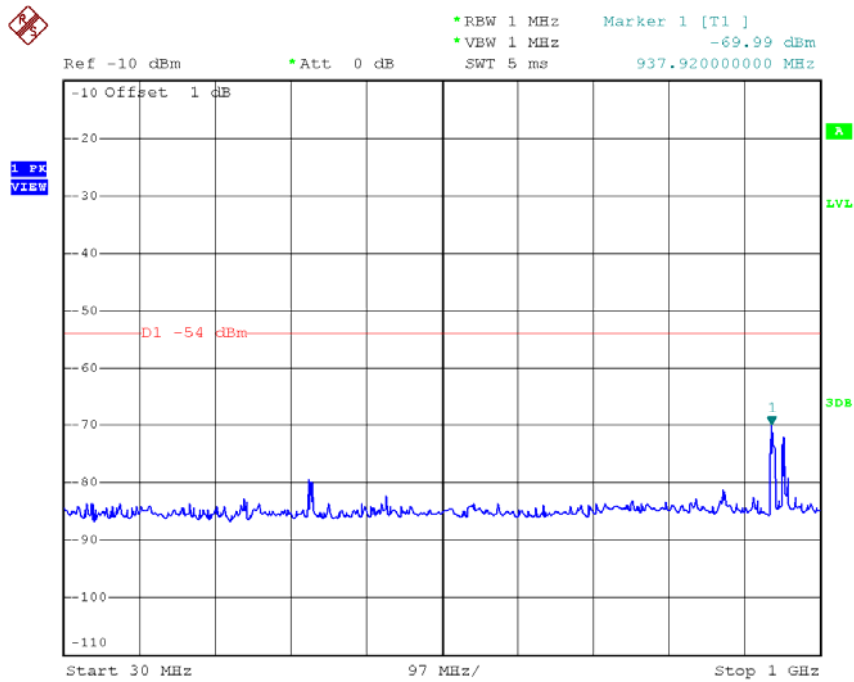

Date: 17.NOV.2015 18:17:25

Normal Voltage
CH01- Frequency Band 7 (1000 MHz \leq f < 12.5 GHz)

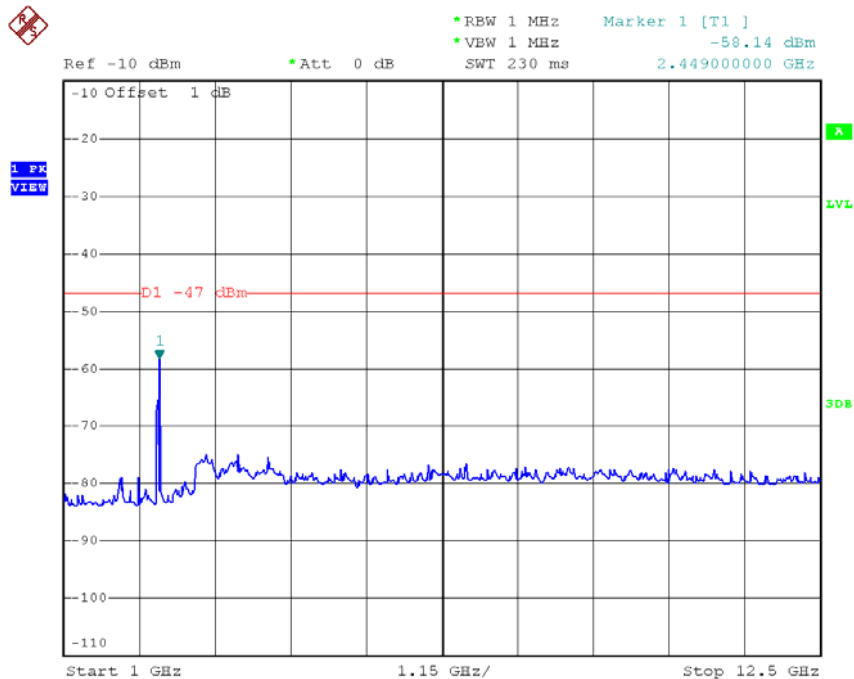

Date: 17.NOV.2015 18:17:36

Normal Voltage CH13- Frequency Band 6 (30 MHz \cong f < 1000 MHz)

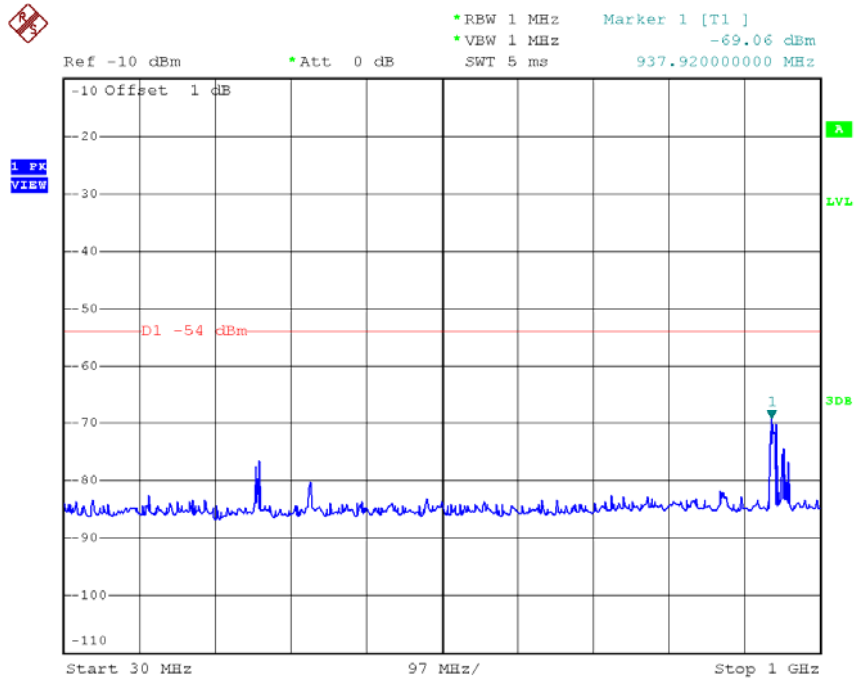

Date: 17.NOV.2015 18:19:34

Normal Voltage CH13- Frequency Band 7 (1000 MHz \cong f < 12.5 GHz)

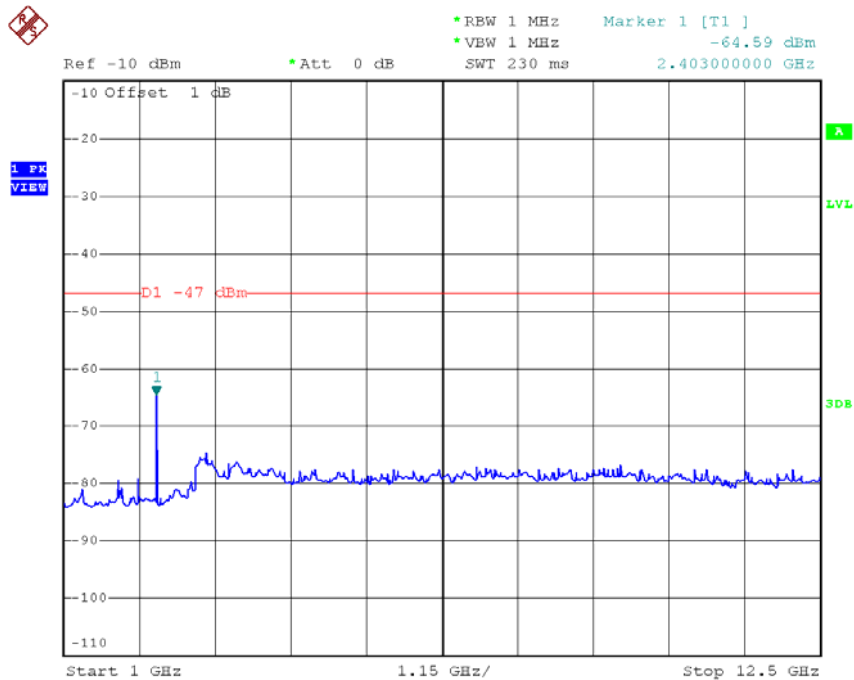

Date: 17.NOV.2015 18:19:45

High Voltage

CH01- Frequency Band 6 (30 MHz \leq f < 1000 MHz)

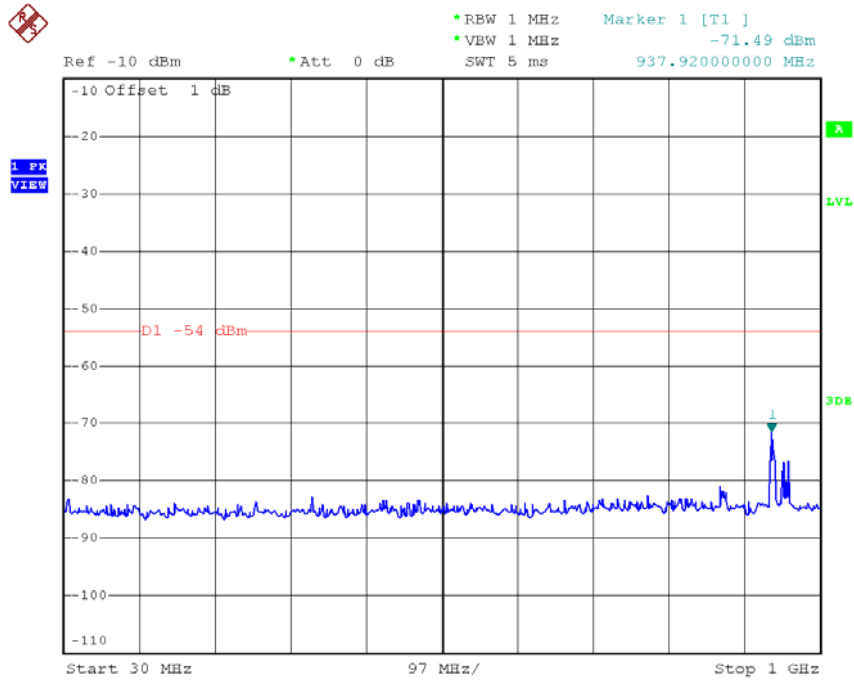

Date: 17.NOV.2015 18:11:53

High Voltage

CH01- Frequency Band 7 (1000 MHz \leq f < 12.5 GHz)

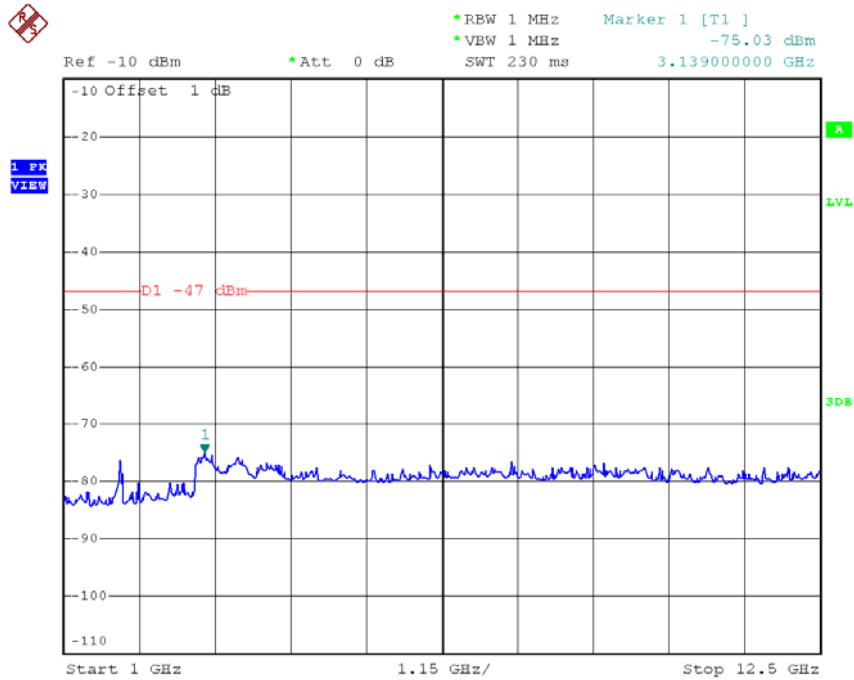

Date: 17.NOV.2015 18:12:04

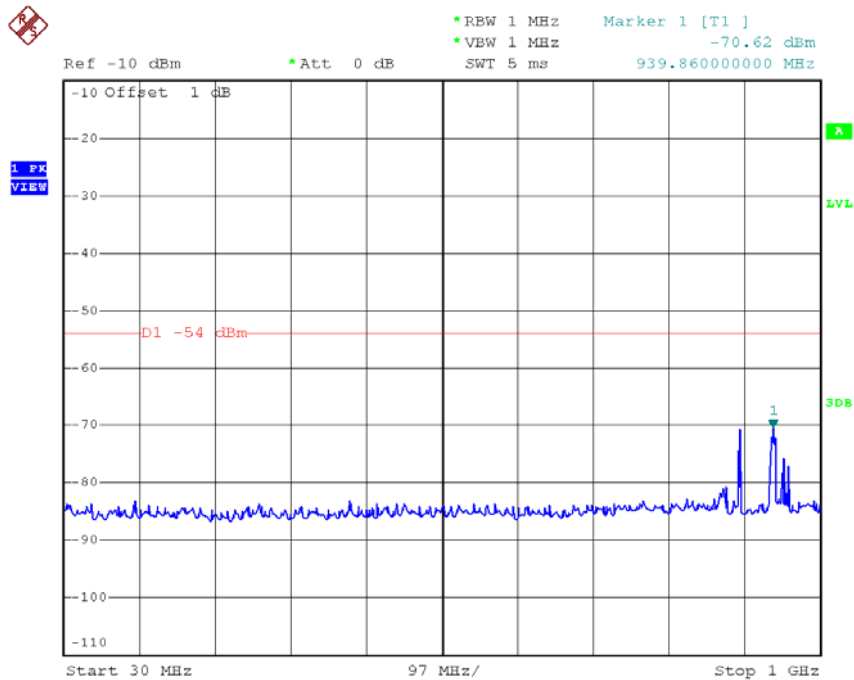
High Voltage**CH07- Frequency Band 6 (30 MHz \cong f < 1000 MHz)**

Date: 17.NOV.2015 18:12:19

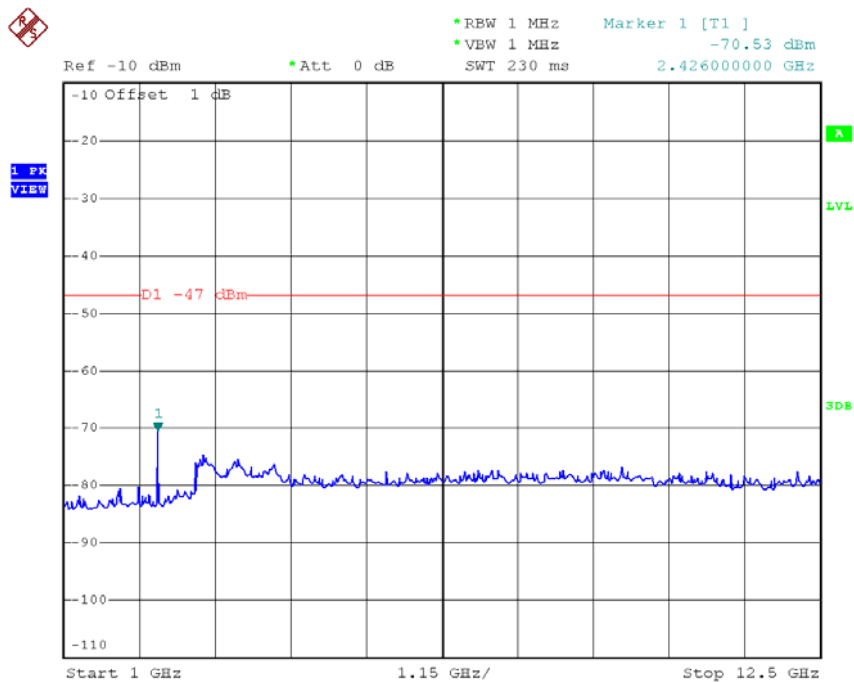
High Voltage**CH07- Frequency Band 7 (1000 MHz \cong f < 12.5 GHz)**

Date: 17.NOV.2015 18:12:30

Low Voltage

CH01- Frequency Band 6 ($30 \text{ MHz} \leq f < 1000 \text{ MHz}$)

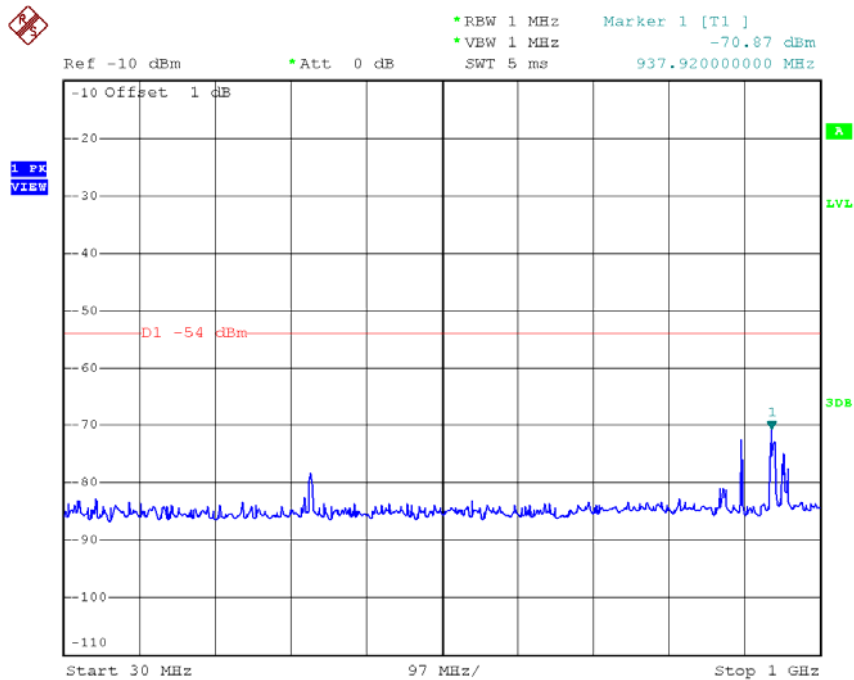

Date: 17.NOV.2015 18:24:01

Low Voltage

CH01- Frequency Band 7 ($1000 \text{ MHz} \leq f < 12.5 \text{ GHz}$)

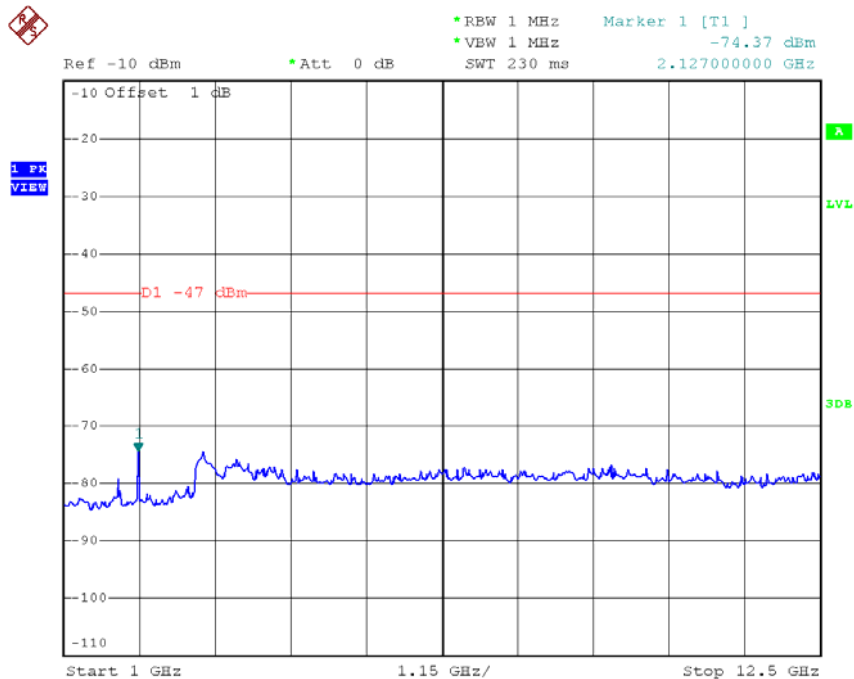

Date: 17.NOV.2015 18:24:12

Low Voltage

CH07- Frequency Band 6 (30 MHz \cong f < 1000 MHz)

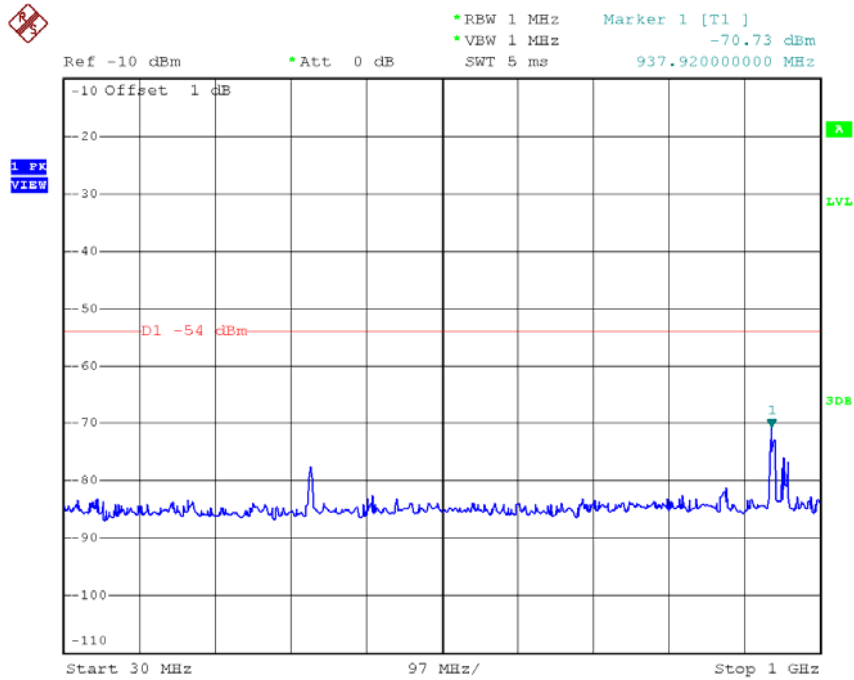

Date: 17.NOV.2015 18:24:26

Low Voltage

CH07- Frequency Band 7 (1000 MHz \cong f < 12.5 GHz)

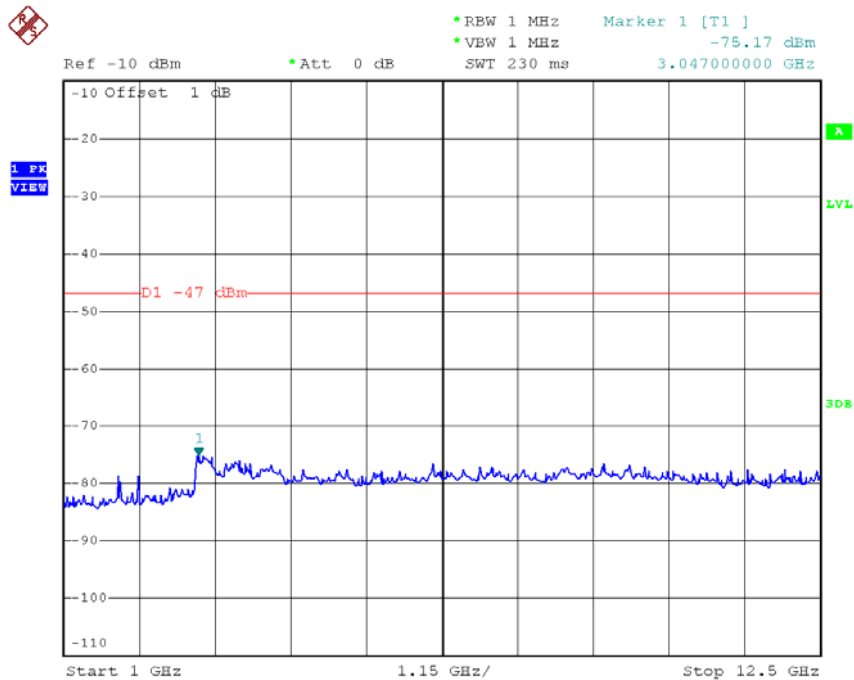

Date: 17.NOV.2015 18:24:36

Low Voltage
CH13- Frequency Band 6 (30 MHz \cong f < 1000 MHz)

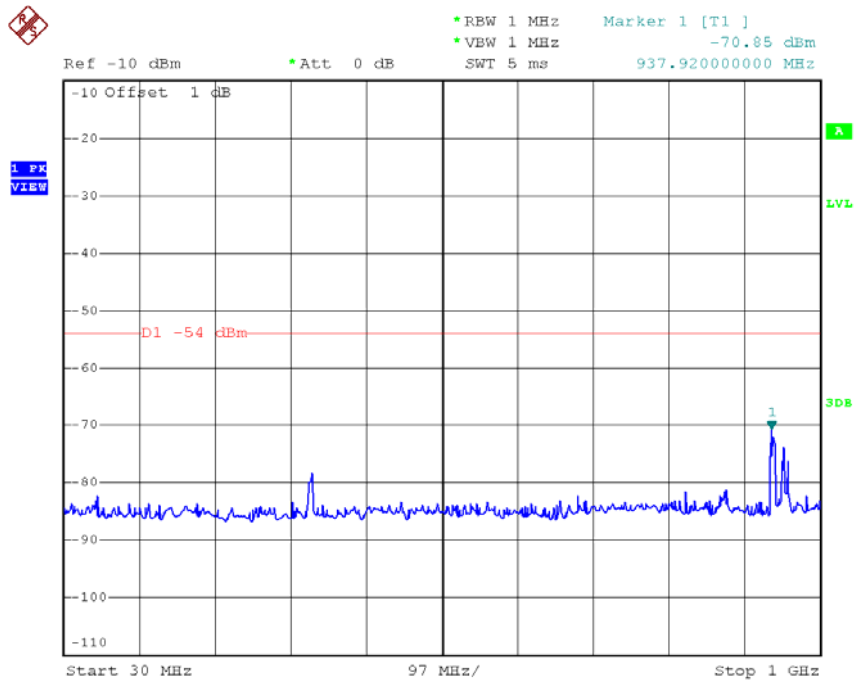

Date: 17.NOV.2015 18:24:49

Low Voltage
CH13- Frequency Band 7 (1000 MHz \cong f < 12.5 GHz)

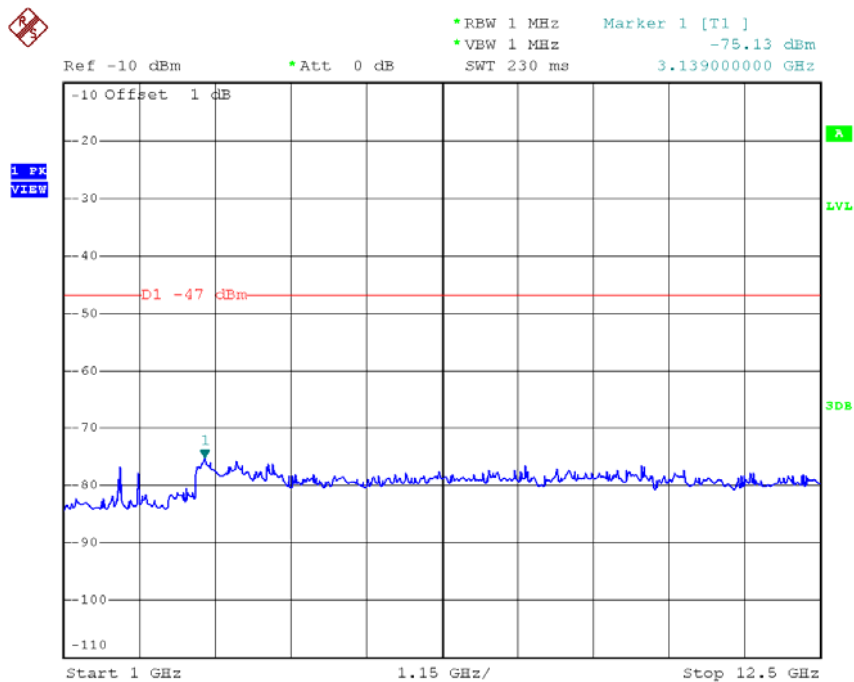

Date: 17.NOV.2015 18:25:00

Test Mode:	802.11n(HT20)/CH01,CH07,CH13
------------	------------------------------

Test Voltage		V	Normal Voltage			Remarks
Test Frequency		MHz	2412	2442	2472	Low/Mid/Low of test frequency range
Limitation of Collateral Emission of Receiver	※6	nW	0.1140	0.0865	0.1117	Limit \leq 4 nW (-54 dBm)
	※7	nW	0.3365	0.0973	0.0445	Limit \leq 20 nW (-47 dBm)

Test Voltage		V	High Voltage			Remarks
Test Frequency		MHz	2412	2442	2472	Low/Mid/Low of test frequency range
Limitation of Collateral Emission of Receiver	※6	nW	0.0861	0.1067	0.1968	Limit \leq 4 nW (-54 dBm)
	※7	nW	0.0301	0.0329	1.6032	Limit \leq 20 nW (-47 dBm)

Test Voltage		V	Low Voltage			Remarks
Test Frequency		MHz	2412	2442	2472	Low/Mid/Low of test frequency range
Limitation of Collateral Emission of Receiver	※6	nW	0.0859	0.0869	0.0914	Limit \leq 4 nW (-54 dBm)
	※7	nW	0.6531	0.0290	0.4721	Limit \leq 20 nW (-47 dBm)

Normal Voltage CH01- Frequency Band 6 (30 MHz \leq f < 1000 MHz)

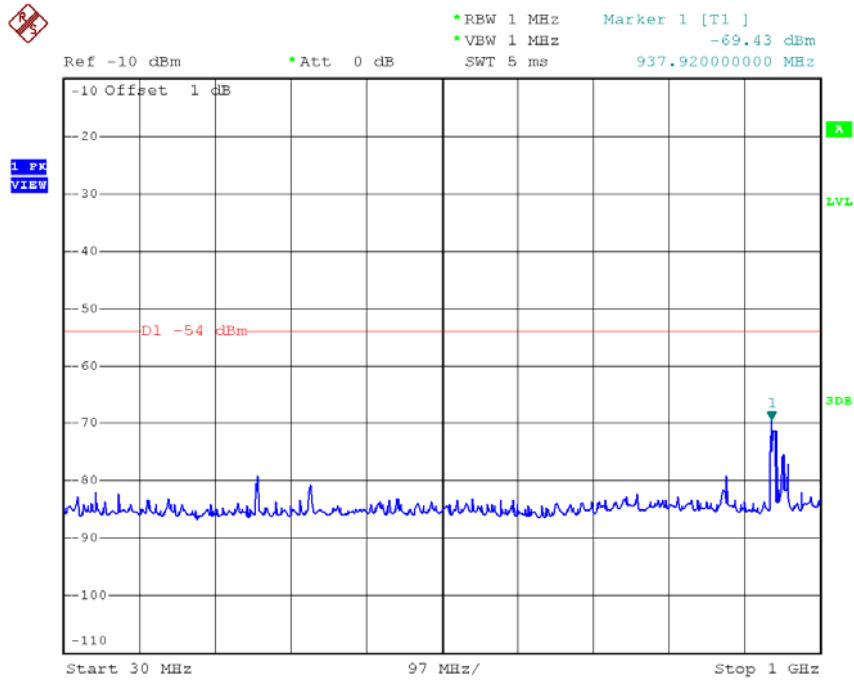

Date: 17.NOV.2015 18:21:38

Normal Voltage CH01- Frequency Band 7 (1000 MHz \leq f < 12.5 GHz)

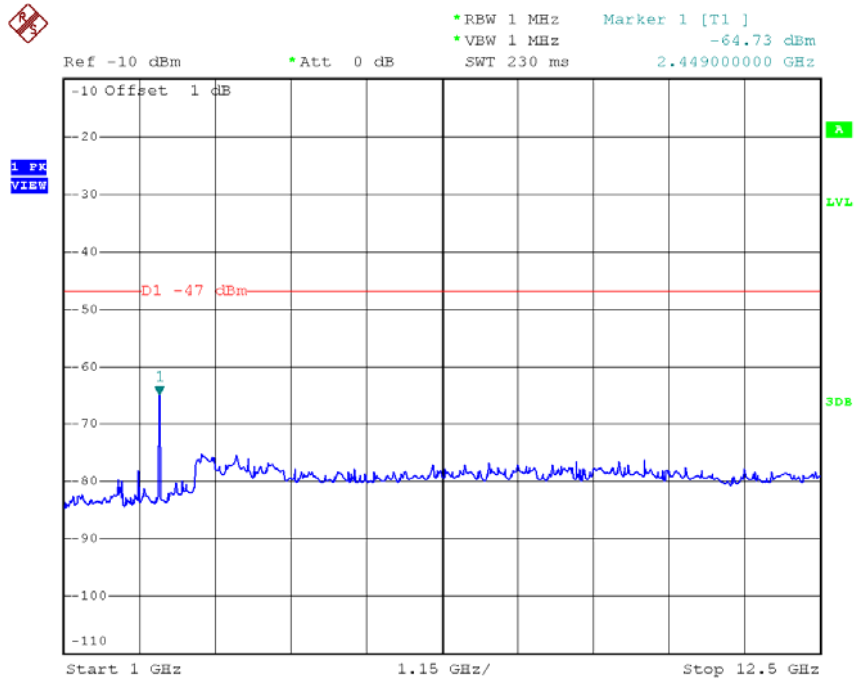

Date: 17.NOV.2015 18:21:50

Normal Voltage CH07- Frequency Band 6 (30 MHz \cong f < 1000 MHz)

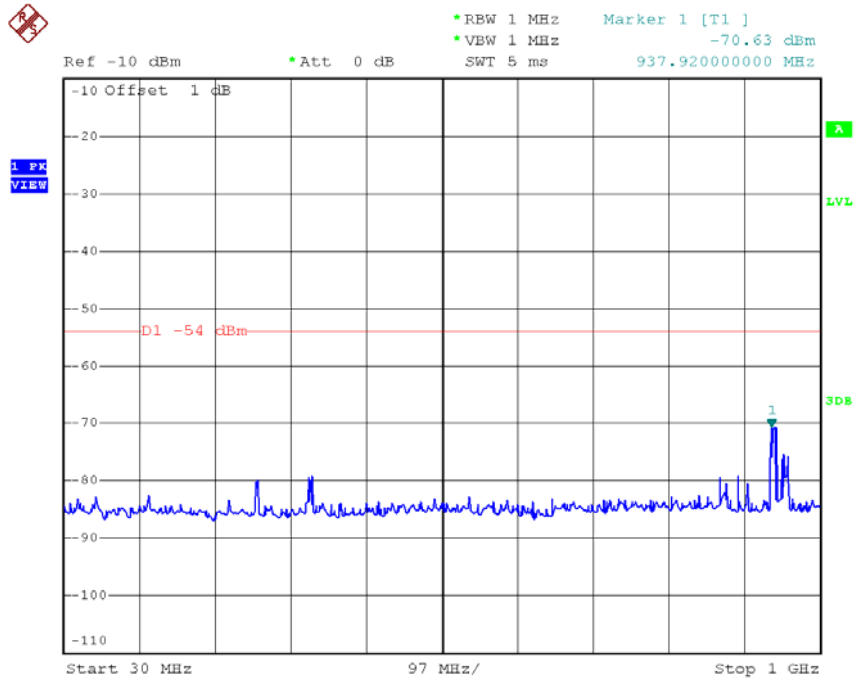

Date: 17.NOV.2015 18:22:06

Normal Voltage CH07- Frequency Band 7 (1000 MHz \cong f < 12.5 GHz)

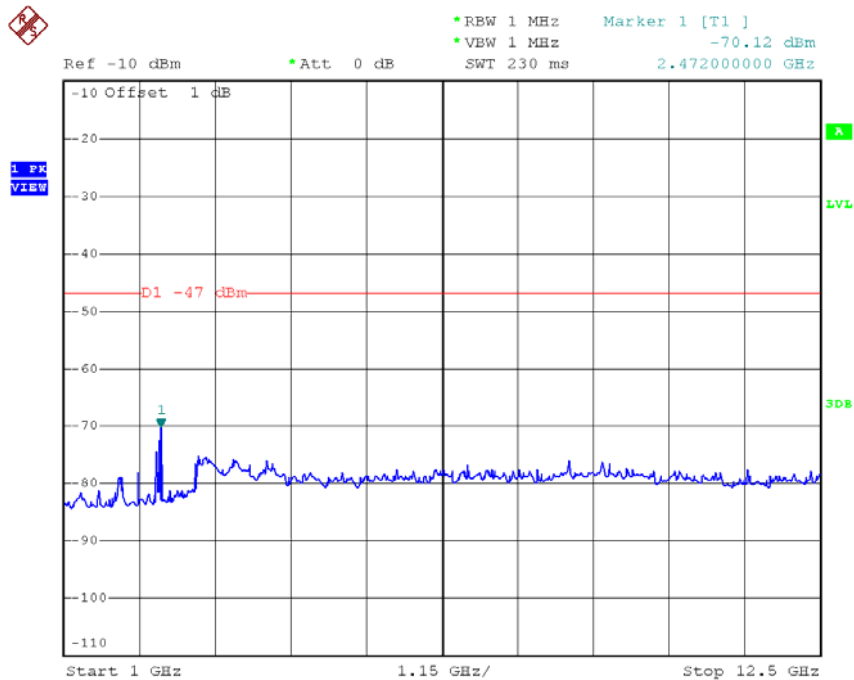

Date: 17.NOV.2015 18:22:17

High Voltage CH01- Frequency Band 6 (30 MHz \leq f < 1000 MHz)

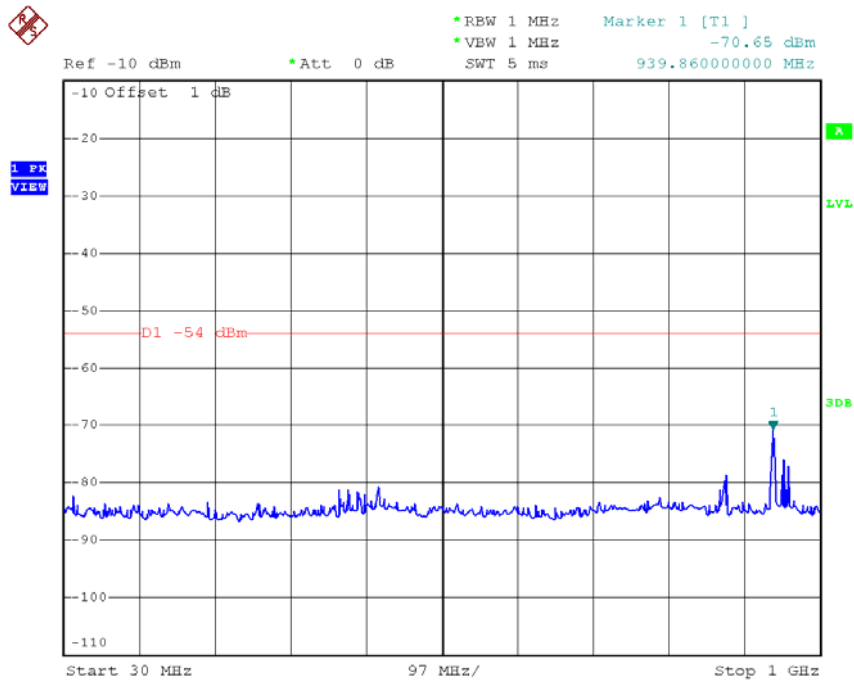

Date: 17.NOV.2015 18:13:18

High Voltage CH01- Frequency Band 7 (1000 MHz \leq f < 12.5 GHz)

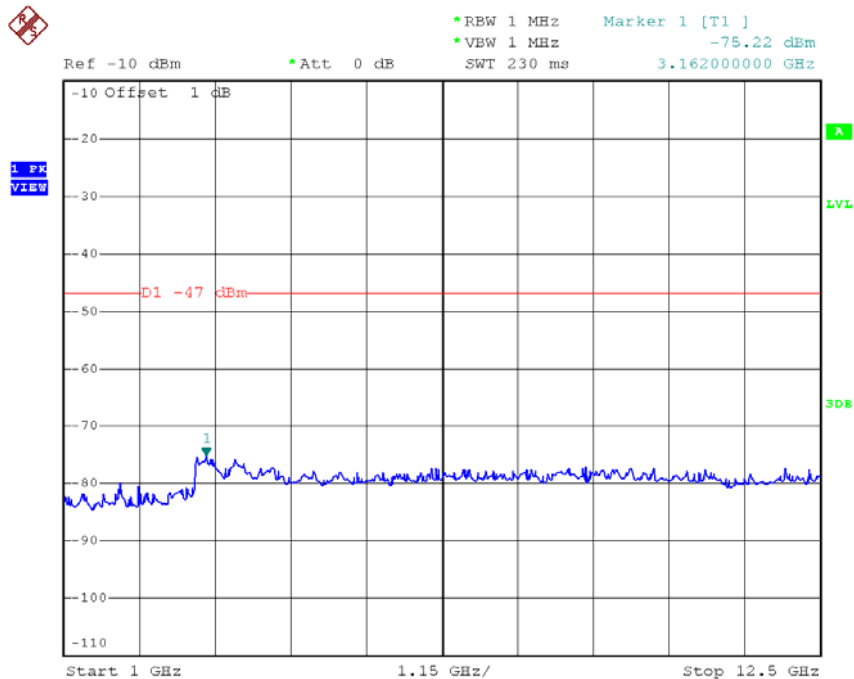

Date: 17.NOV.2015 18:13:29

High Voltage CH13- Frequency Band 6 (30 MHz \cong f < 1000 MHz)

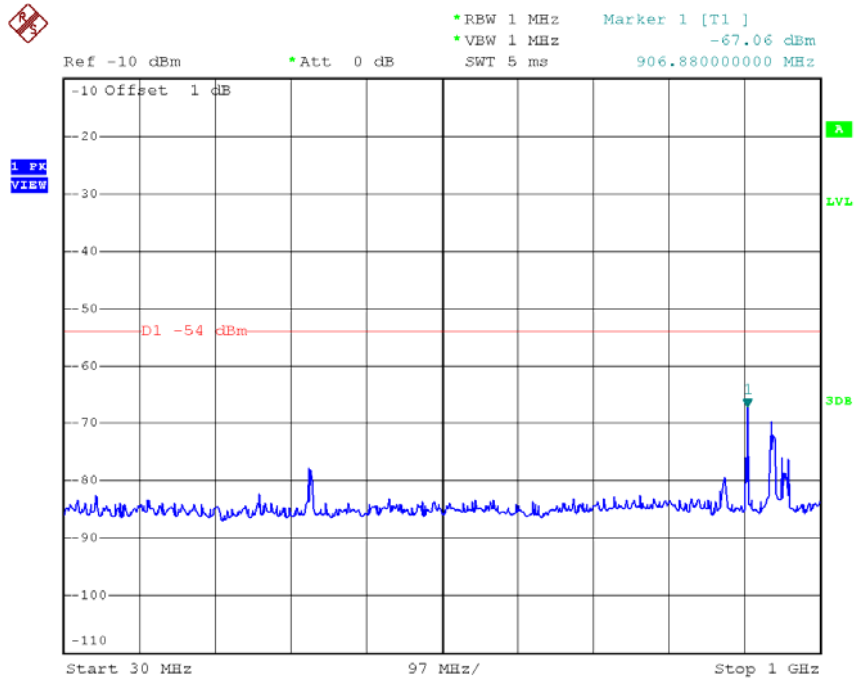

Date: 17.NOV.2015 18:28:31

High Voltage CH13- Frequency Band 7 (1000 MHz \cong f < 12.5 GHz)

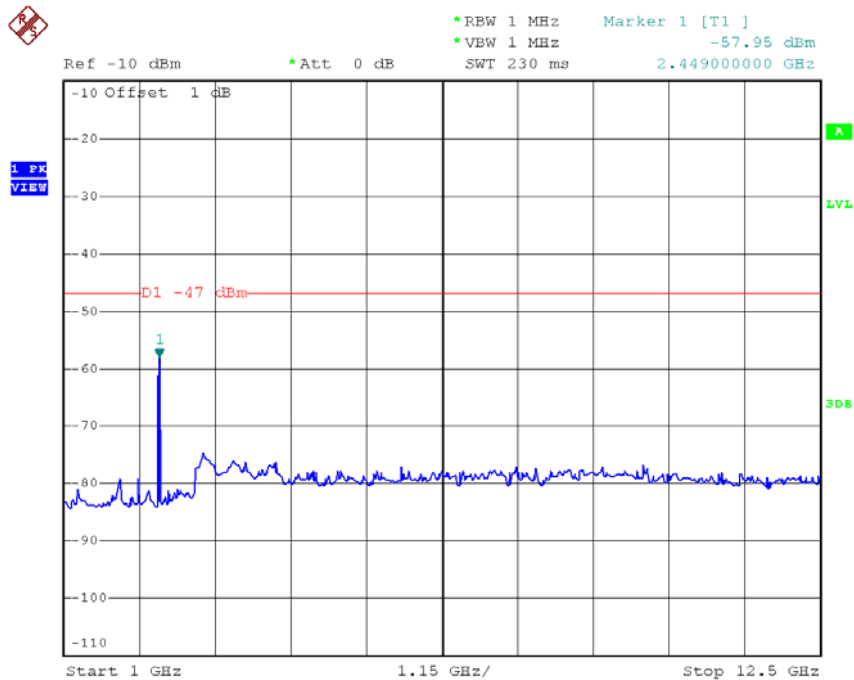

Date: 17.NOV.2015 18:15:06

Low Voltage

CH01- Frequency Band 6 (30 MHz \leq f < 1000 MHz)

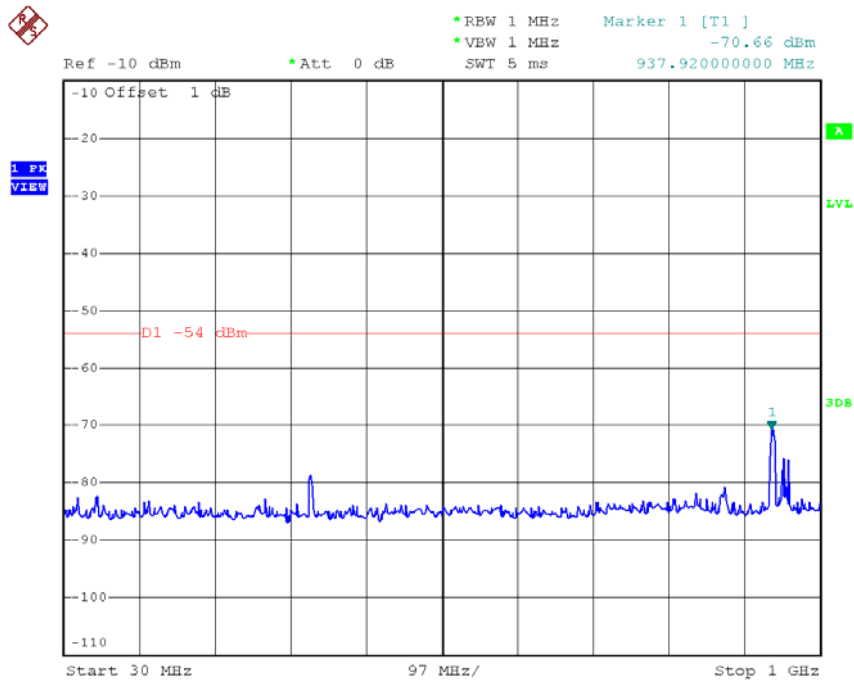

Date: 17.NOV.2015 18:25:12

Low Voltage

CH01- Frequency Band 7 (1000 MHz \leq f < 12.5 GHz)

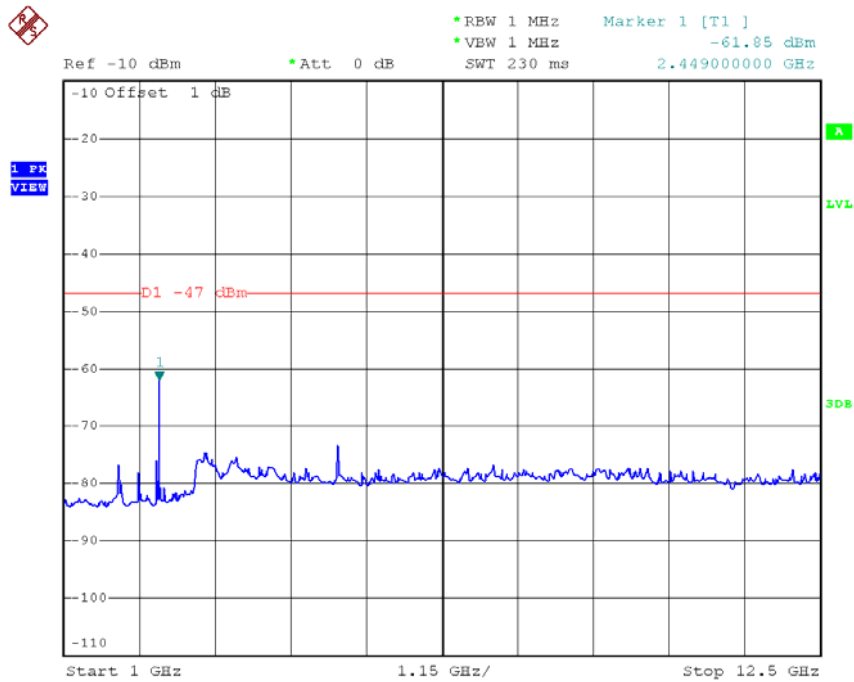

Date: 17.NOV.2015 18:25:23

Low Voltage

CH07- Frequency Band 6 (30 MHz \cong f < 1000 MHz)

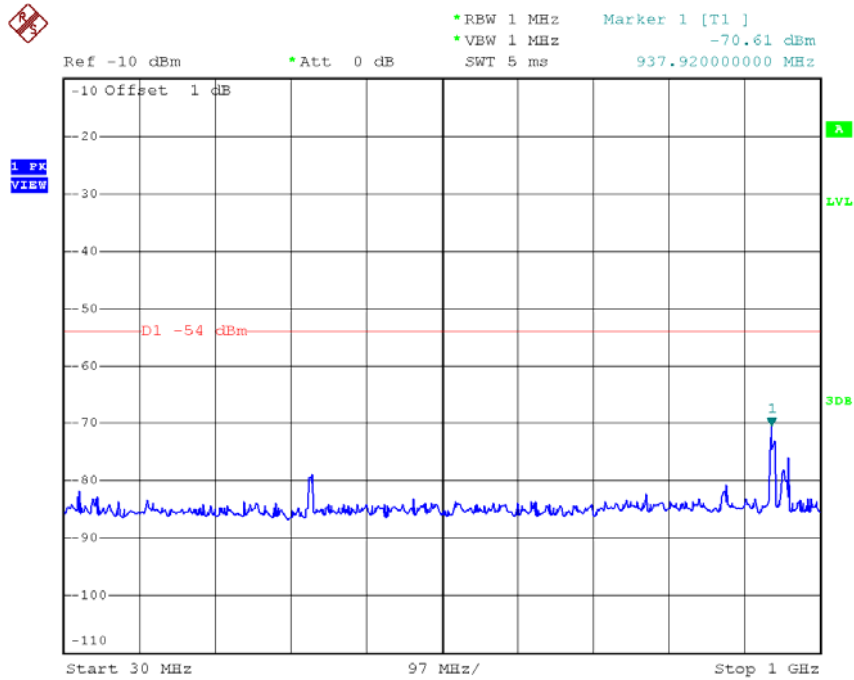

Date: 17.NOV.2015 18:25:35

Low Voltage

CH07- Frequency Band 7 (1000 MHz \cong f < 12.5 GHz)

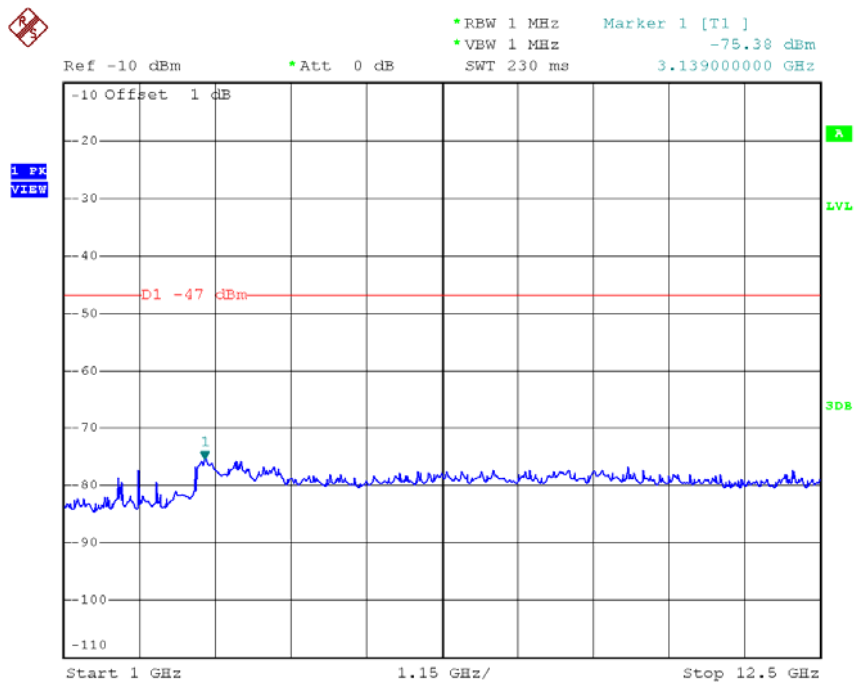

Date: 17.NOV.2015 18:25:46

Low Voltage

CH13- Frequency Band 6 (30 MHz \cong f < 1000 MHz)

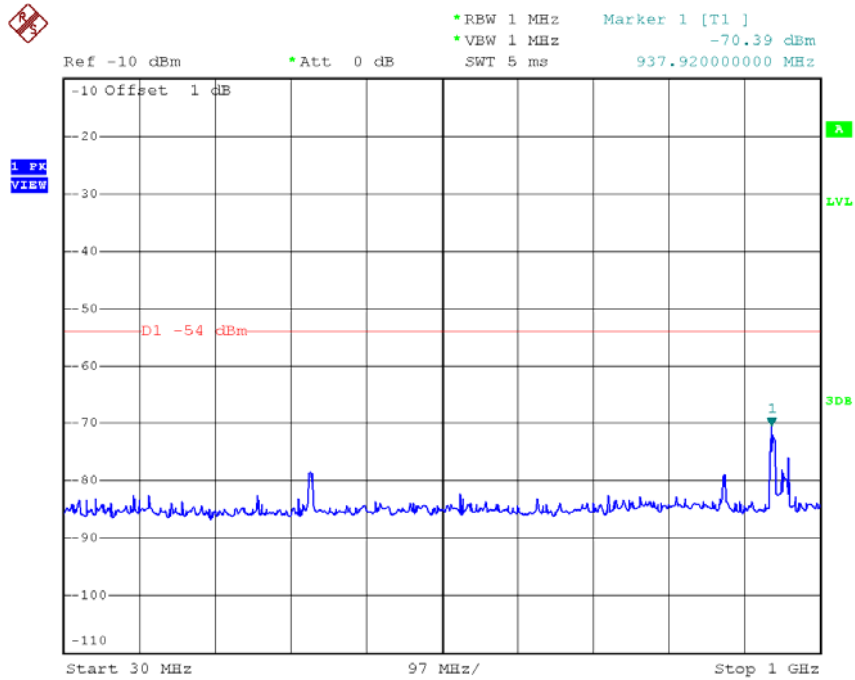

Date: 17.NOV.2015 18:29:18

Low Voltage

CH13- Frequency Band 7 (1000 MHz \cong f < 12.5 GHz)

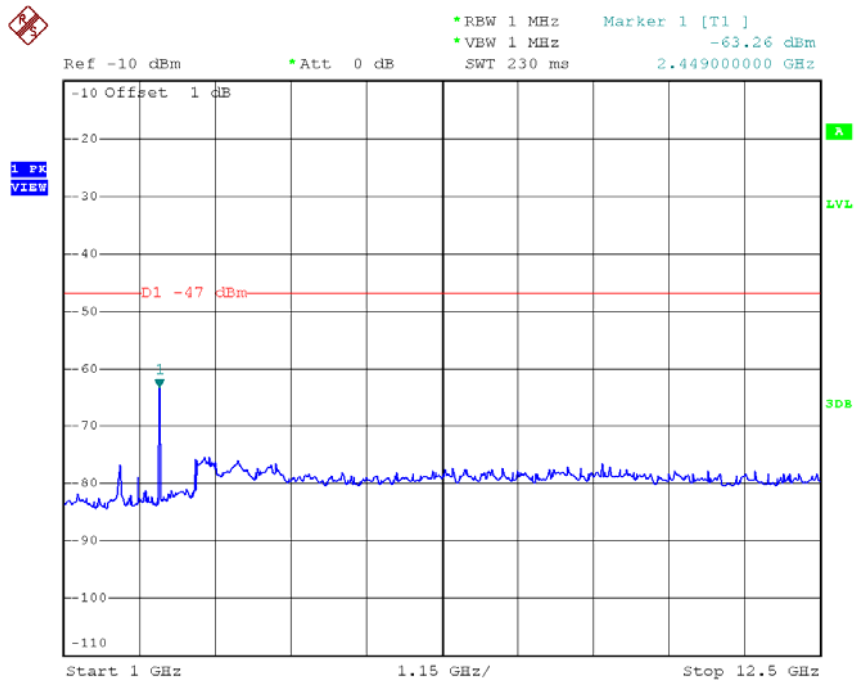

Date: 17.NOV.2015 18:26:09

For Dipole antenna

Test Mode:	802.11b/CH01,CH07,CH13
------------	------------------------

Test Voltage		V	Normal Voltage			Remarks
Test Frequency		MHz	2412	2442	2472	Low/Mid/Low of test frequency range
Limitation of Collateral Emission of Receiver	※6	nW	0.0101	0.0076	0.0084	Limit ≦ 4 nW (-54 dBm)
	※7	nW	0.0288	0.0308	0.0336	Limit ≦ 20 nW (-47 dBm)

Test Voltage		V	High Voltage			Remarks
Test Frequency		MHz	2412	2442	2472	Low/Mid/Low of test frequency range
Limitation of Collateral Emission of Receiver	※6	nW	0.0107	0.0104	0.0107	Limit ≦ 4 nW (-54 dBm)
	※7	nW	0.0303	0.0292	0.0313	Limit ≦ 20 nW (-47 dBm)

Test Voltage		V	Low Voltage			Remarks
Test Frequency		MHz	2412	2442	2472	Low/Mid/Low of test frequency range
Limitation of Collateral Emission of Receiver	※6	nW	0.0113	0.0083	0.0078	Limit ≦ 4 nW (-54 dBm)
	※7	nW	0.0275	0.0326	0.0273	Limit ≦ 20 nW (-47 dBm)

Normal Voltage

CH01- Frequency Band 6 (30 MHz \leq f < 1000 MHz)

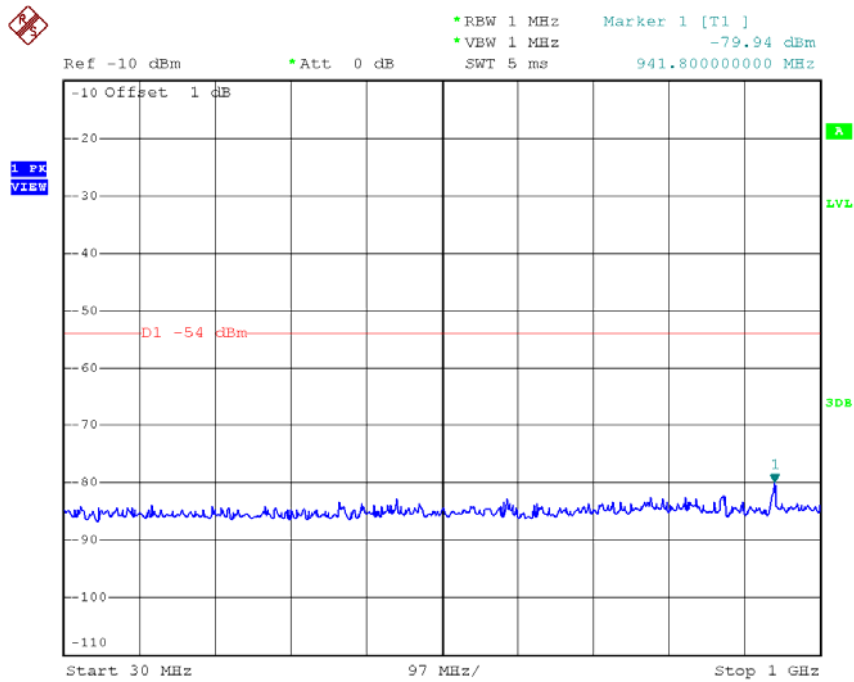

Date: 14.NOV.2015 14:44:17

Normal Voltage

CH01- Frequency Band 7 (1000 MHz \leq f < 12.5 GHz)

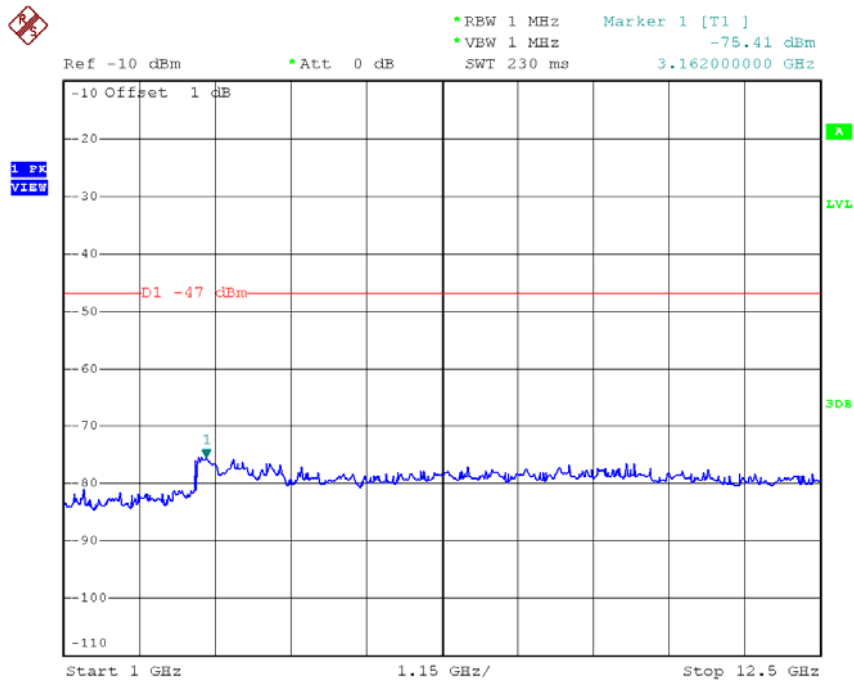

Date: 14.NOV.2015 14:30:01

Normal Voltage
CH07- Frequency Band 6 (30 MHz \cong f < 1000 MHz)

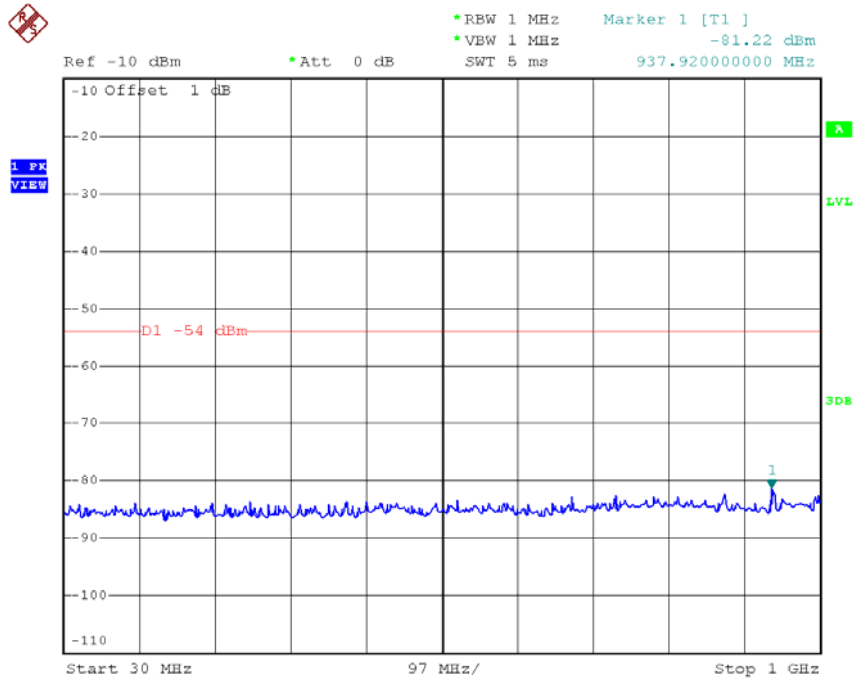

Date: 14.NOV.2015 14:44:30

Normal Voltage
CH07- Frequency Band 7 (1000 MHz \cong f < 12.5 GHz)

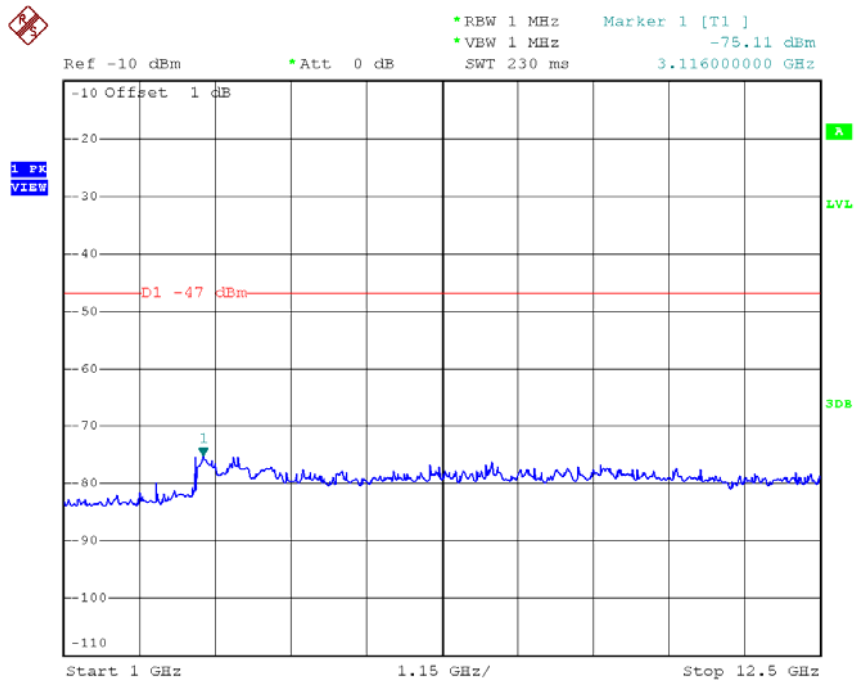

Date: 14.NOV.2015 14:30:26

Normal Voltage CH13- Frequency Band 6 (30 MHz \cong f < 1000 MHz)

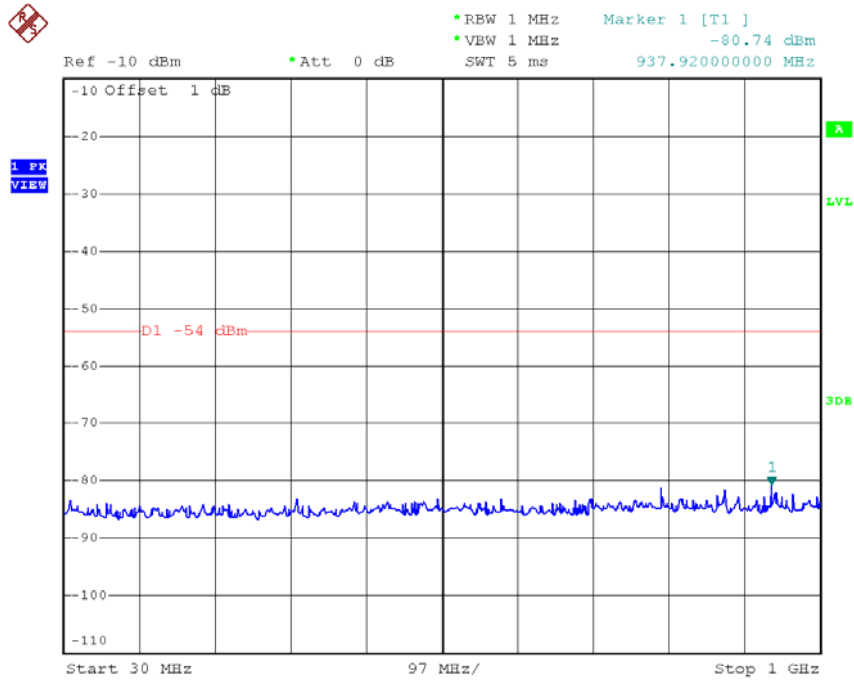

Date: 14.NOV.2015 14:44:41

Normal Voltage CH13- Frequency Band 7 (1000 MHz \cong f < 12.5 GHz)

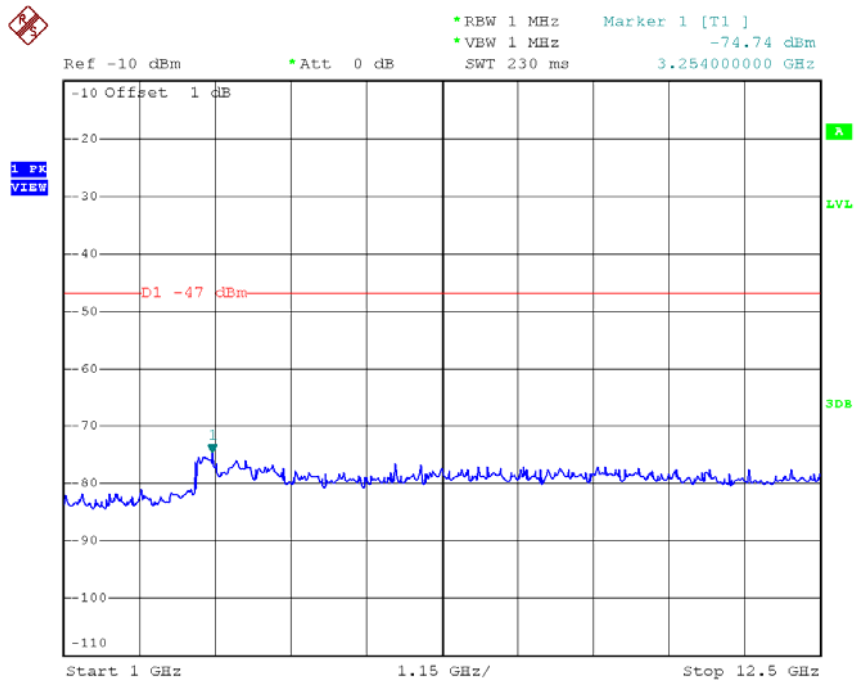

Date: 14.NOV.2015 14:30:49

High Voltage CH01- Frequency Band 6 (30 MHz \leq f < 1000 MHz)

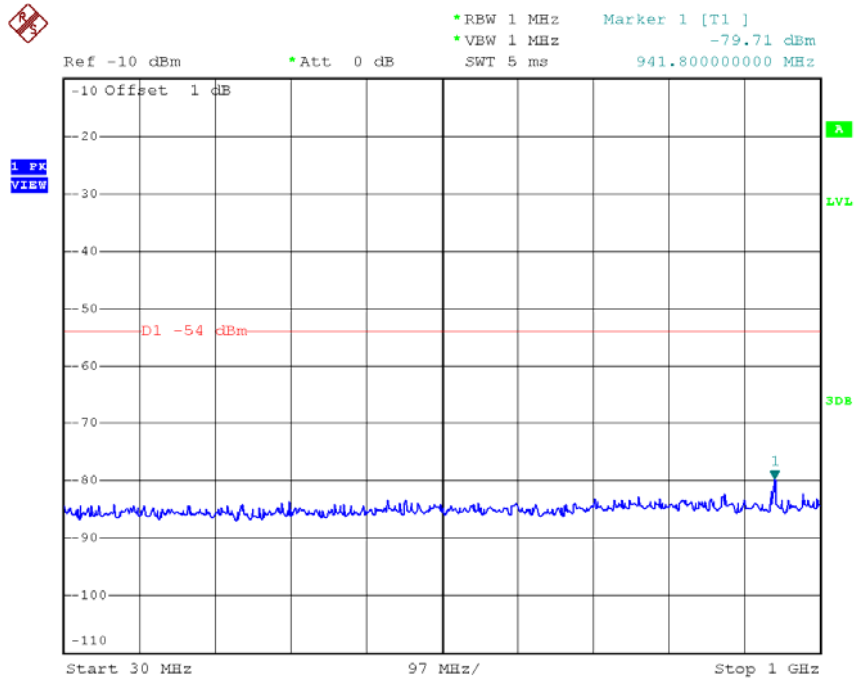

Date: 14.NOV.2015 14:46:48

High Voltage CH01- Frequency Band 7 (1000 MHz \leq f < 12.5 GHz)

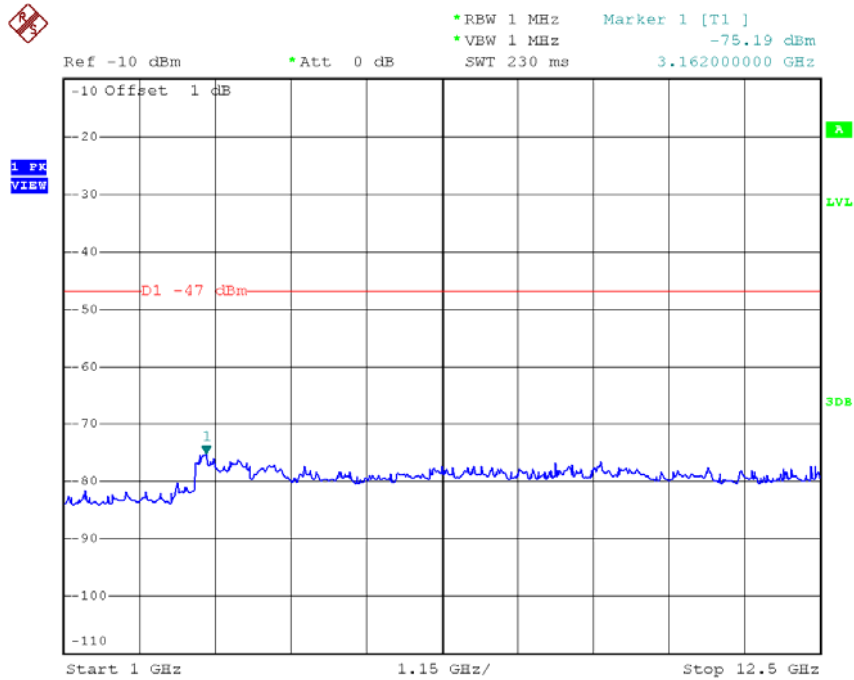

Date: 14.NOV.2015 14:26:11

High Voltage CH07- Frequency Band 6 (30 MHz \cong f < 1000 MHz)

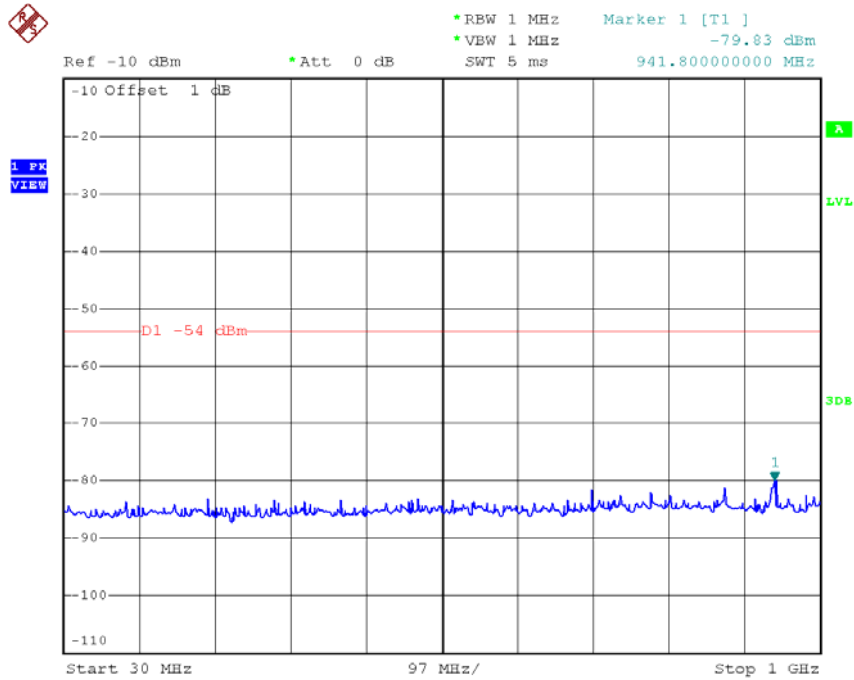

Date: 14.NOV.2015 14:47:00

High Voltage CH07- Frequency Band 7 (1000 MHz \cong f < 12.5 GHz)

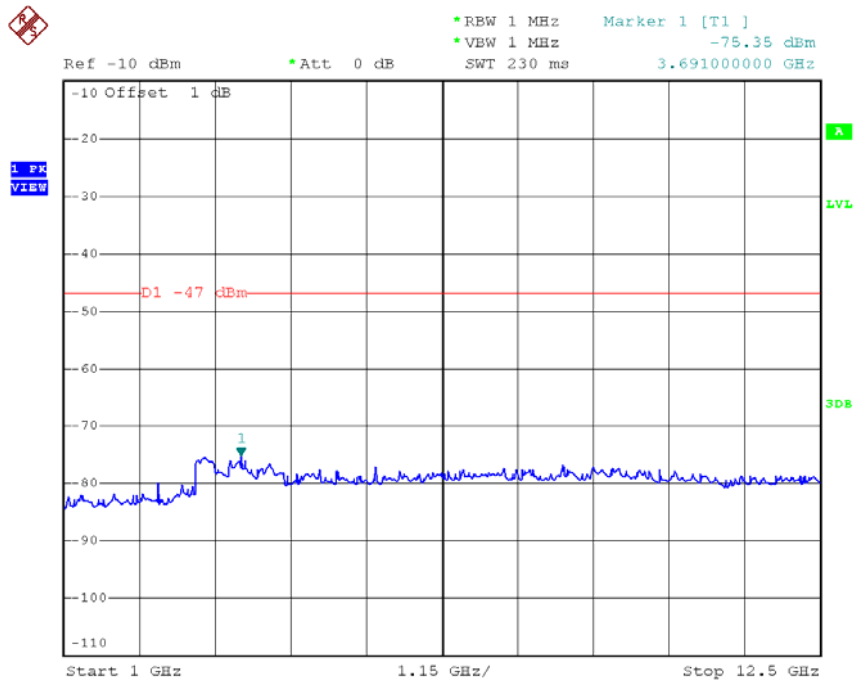

Date: 14.NOV.2015 14:26:35

Low Voltage

CH01- Frequency Band 6 (30 MHz \leq f < 1000 MHz)

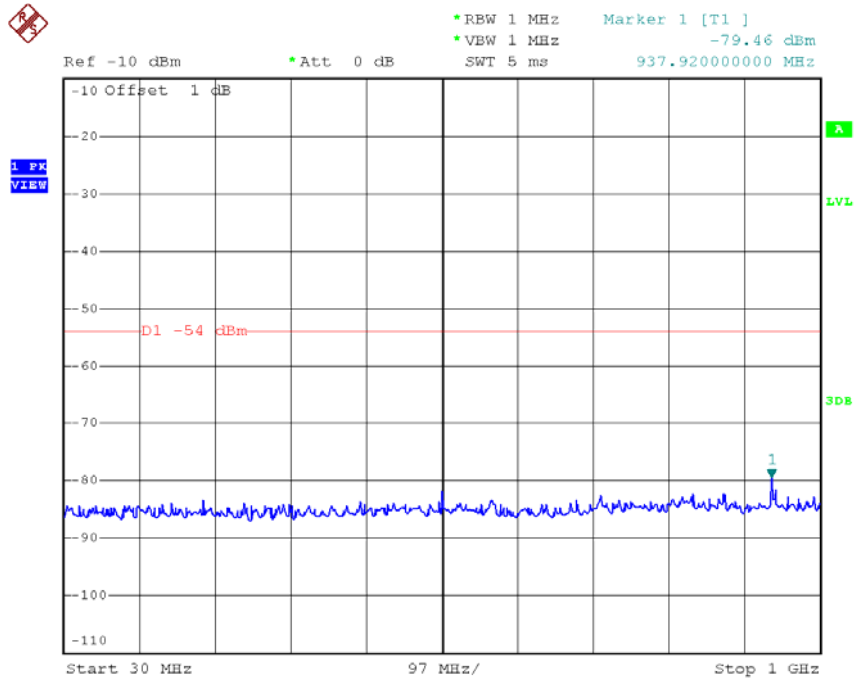

Date: 14.NOV.2015 14:49:08

Low Voltage

CH01- Frequency Band 7 (1000 MHz \leq f < 12.5 GHz)

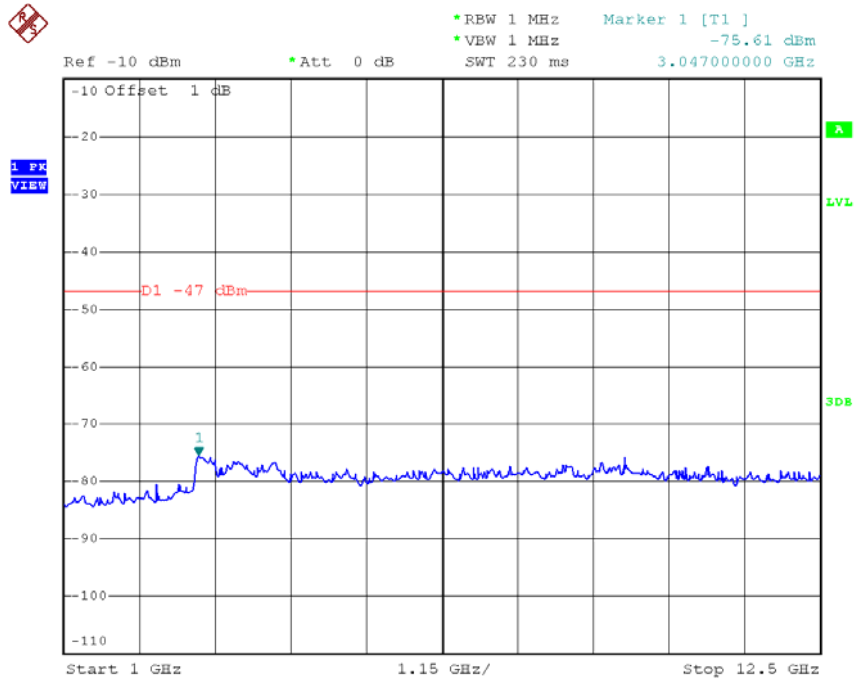

Date: 14.NOV.2015 14:33:39

Low Voltage
CH07- Frequency Band 6 (30 MHz \leq f < 1000 MHz)

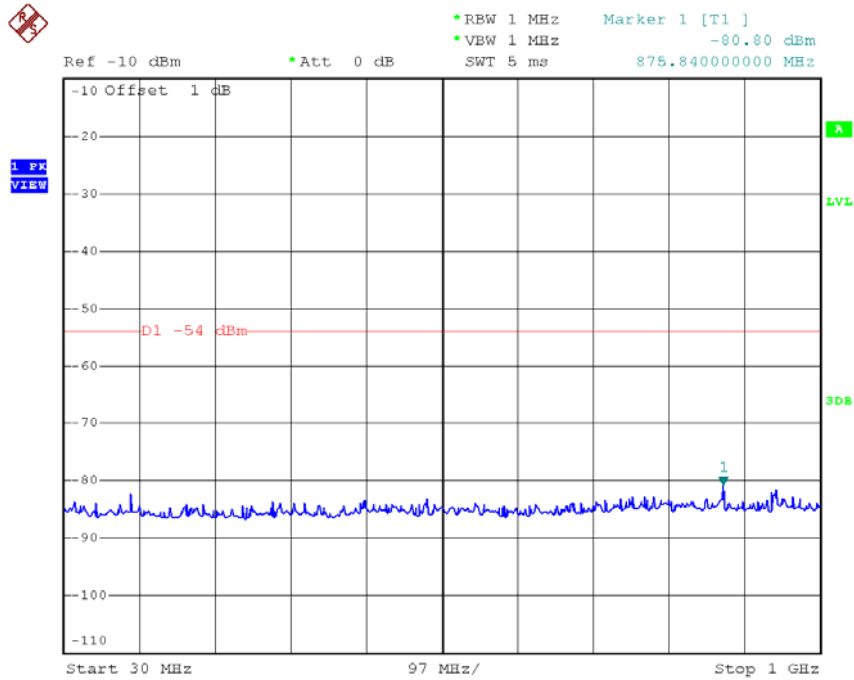

Date: 14.NOV.2015 14:49:20

Low Voltage
CH07- Frequency Band 7 (1000 MHz \leq f < 12.5 GHz)

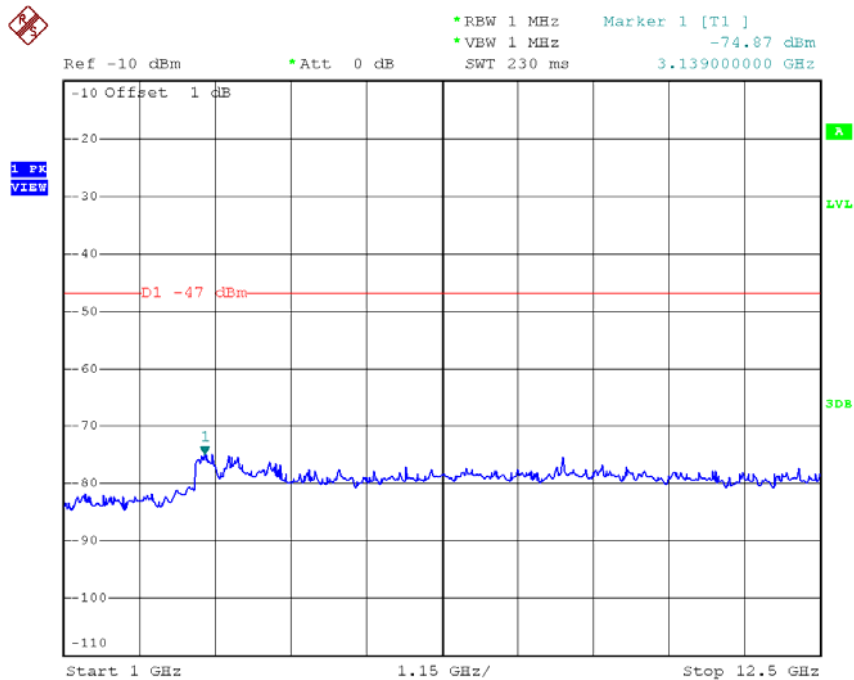

Date: 14.NOV.2015 14:34:47

Test Mode:	802.11g/CH01,CH07,CH13
------------	------------------------

Test Voltage		V	Normal Voltage			Remarks
Test Frequency		MHz	2412	2442	2472	Low/Mid/Low of test frequency range
Limitation of Collateral Emission of Receiver	※6	nW	0.0075	0.0079	0.0110	Limit \leq 4 nW (-54 dBm)
	※7	nW	0.0296	0.0324	0.0378	Limit \leq 20 nW (-47 dBm)

Test Voltage		V	High Voltage			Remarks
Test Frequency		MHz	2412	2442	2472	Low/Mid/Low of test frequency range
Limitation of Collateral Emission of Receiver	※6	nW	0.0146	0.0073	0.0077	Limit \leq 4 nW (-54 dBm)
	※7	nW	0.0324	0.0341	0.0312	Limit \leq 20 nW (-47 dBm)

Test Voltage		V	Low Voltage			Remarks
Test Frequency		MHz	2412	2442	2472	Low/Mid/Low of test frequency range
Limitation of Collateral Emission of Receiver	※6	nW	0.0090	0.0076	0.0080	Limit \leq 4 nW (-54 dBm)
	※7	nW	0.0542	0.0575	0.0313	Limit \leq 20 nW (-47 dBm)

Normal Voltage
CH01- Frequency Band 6 (30 MHz \leq f < 1000 MHz)

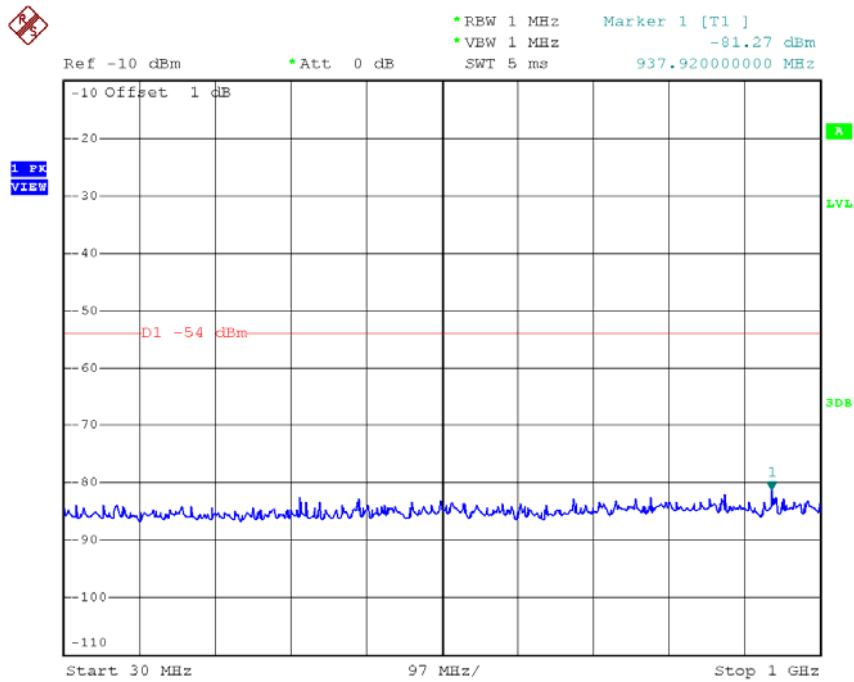

Date: 14.NOV.2015 14:44:53

Normal Voltage
CH01- Frequency Band 7 (1000 MHz \leq f < 12.5 GHz)

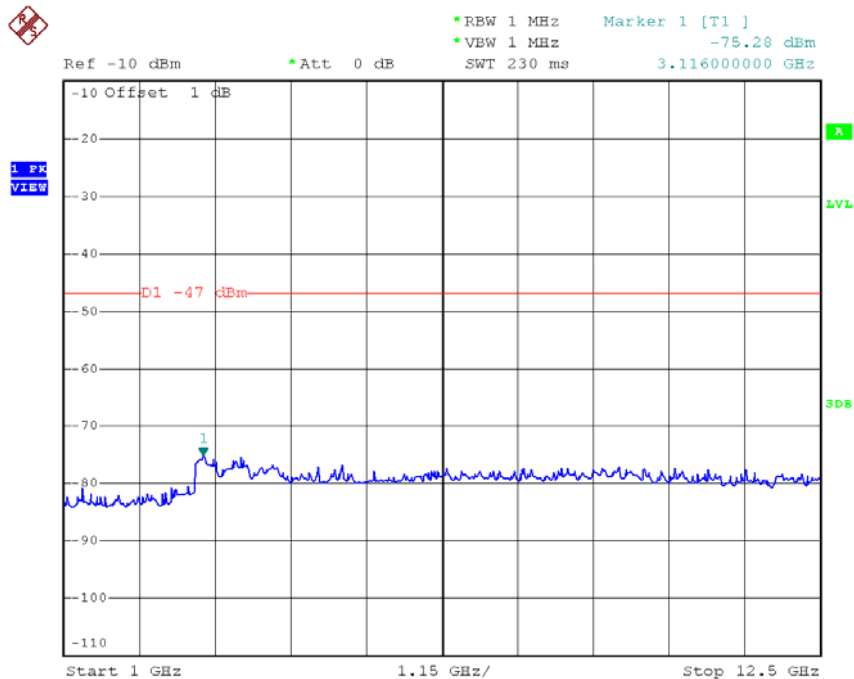

Date: 14.NOV.2015 14:31:12

Normal Voltage
CH07- Frequency Band 6 (30 MHz \cong f < 1000 MHz)

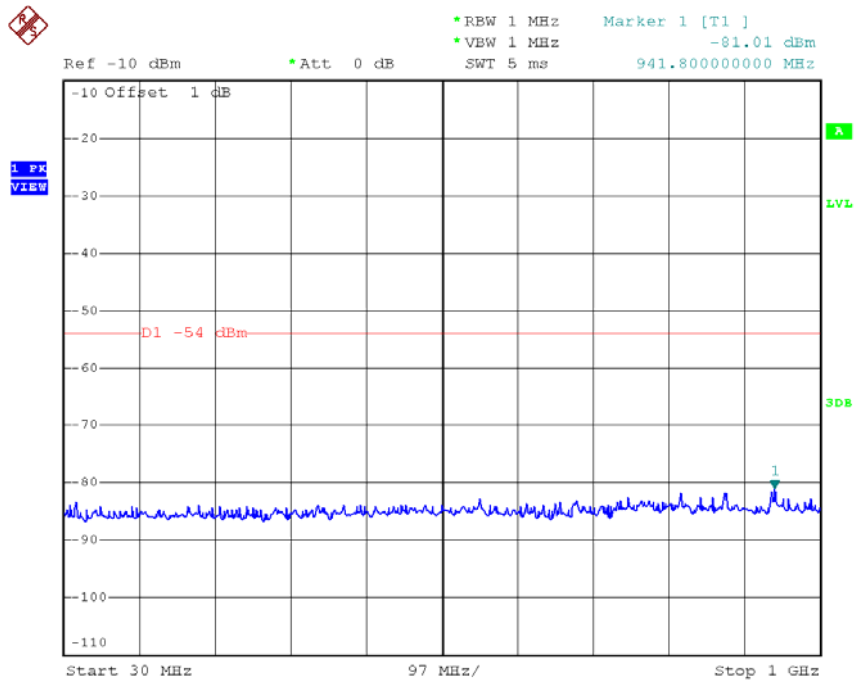

Date: 14.NOV.2015 14:45:07

Normal Voltage
CH07- Frequency Band 7 (1000 MHz \cong f < 12.5 GHz)

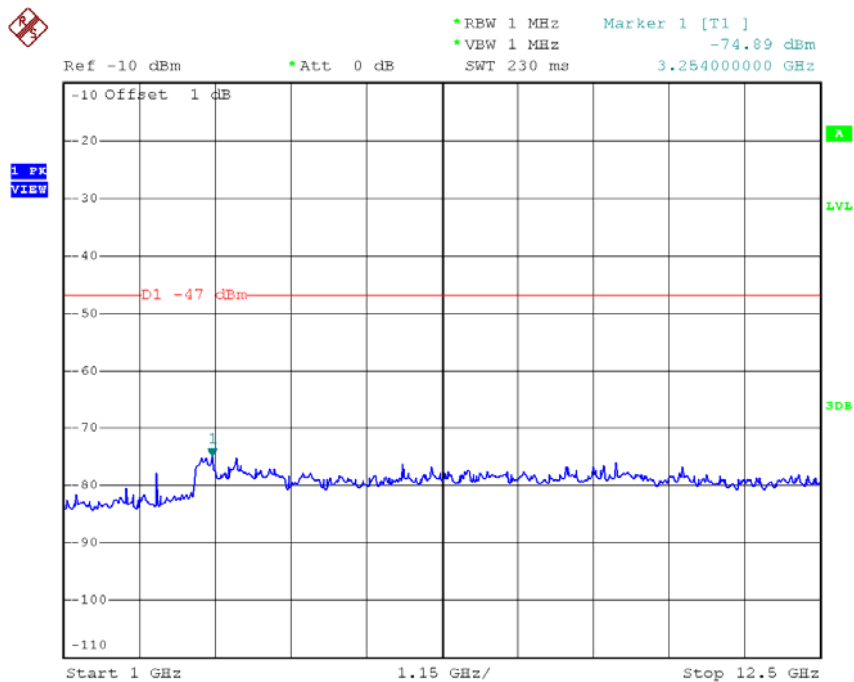

Date: 14.NOV.2015 14:31:36

High Voltage CH01- Frequency Band 6 (30 MHz \leq f < 1000 MHz)

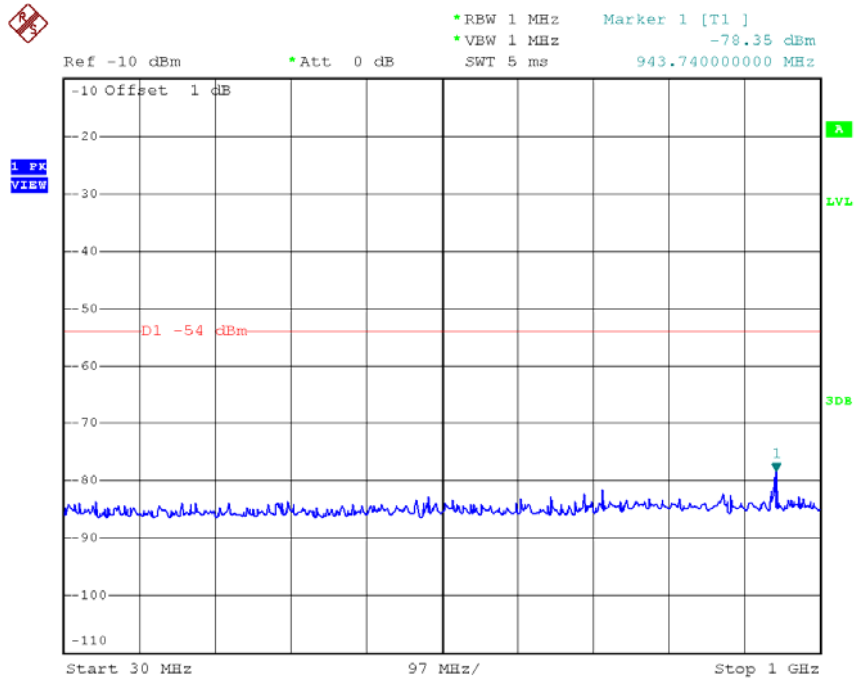

Date: 14.NOV.2015 14:47:22

High Voltage CH01- Frequency Band 7 (1000 MHz \leq f < 12.5 GHz)

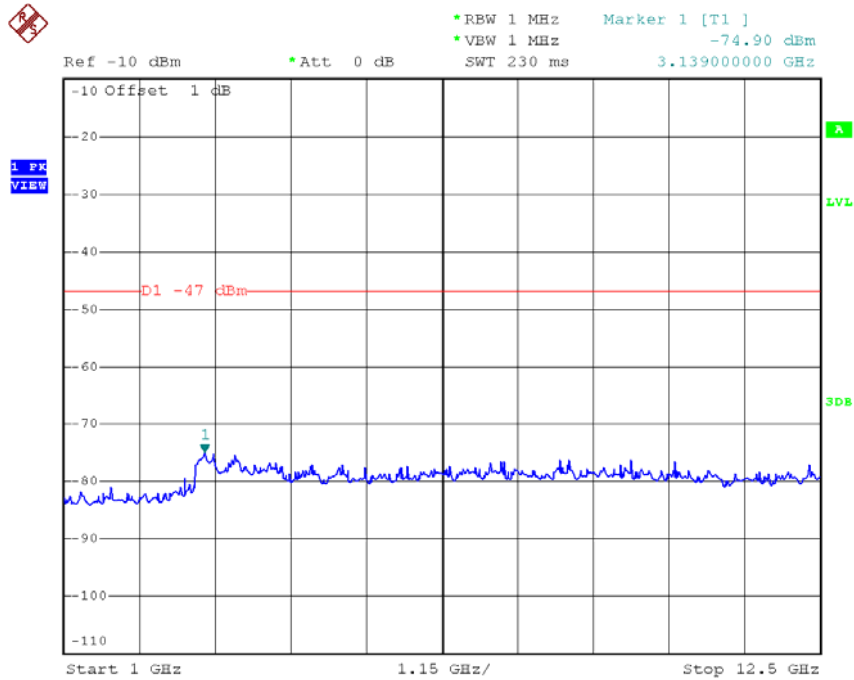

Date: 14.NOV.2015 14:27:36

High Voltage CH13- Frequency Band 6 (30 MHz \leq f < 1000 MHz)

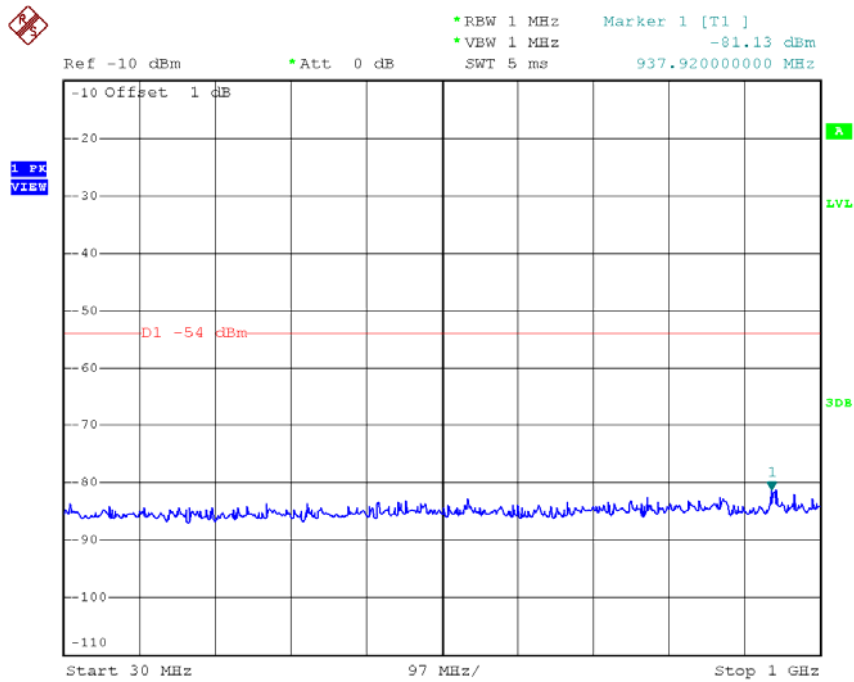

Date: 14.NOV.2015 14:47:47

High Voltage CH13- Frequency Band 7 (1000 MHz \leq f < 12.5 GHz)

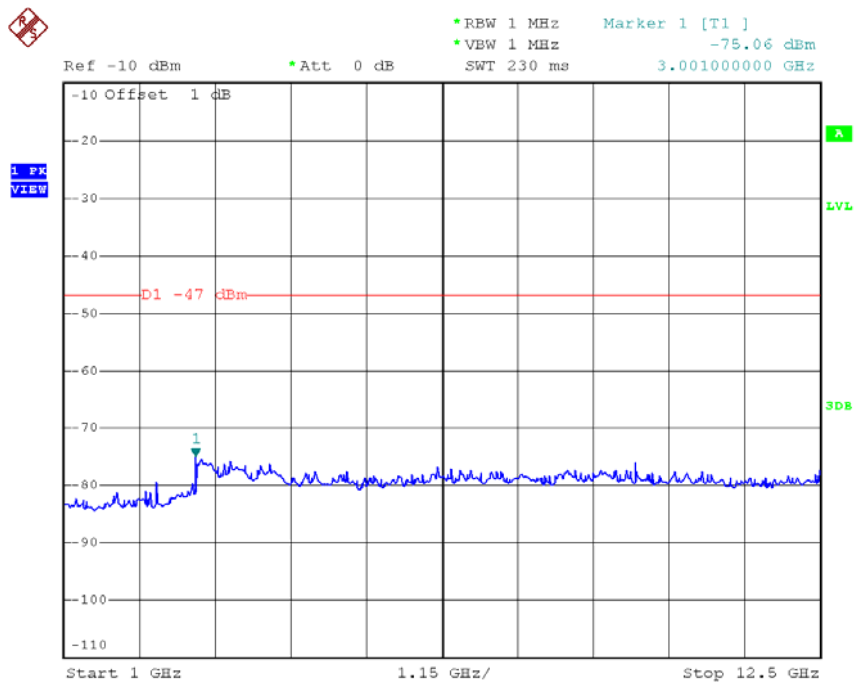

Date: 14.NOV.2015 14:28:21

Low Voltage

CH01- Frequency Band 6 (30 MHz \leq f < 1000 MHz)

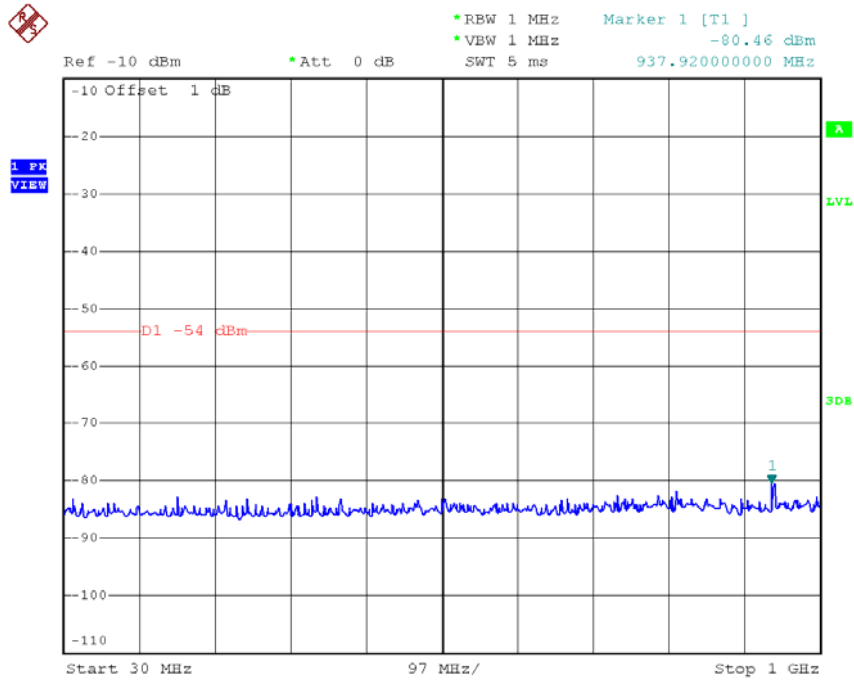

Date: 14.NOV.2015 14:49:45

Low Voltage

CH01- Frequency Band 7 (1000 MHz \leq f < 12.5 GHz)

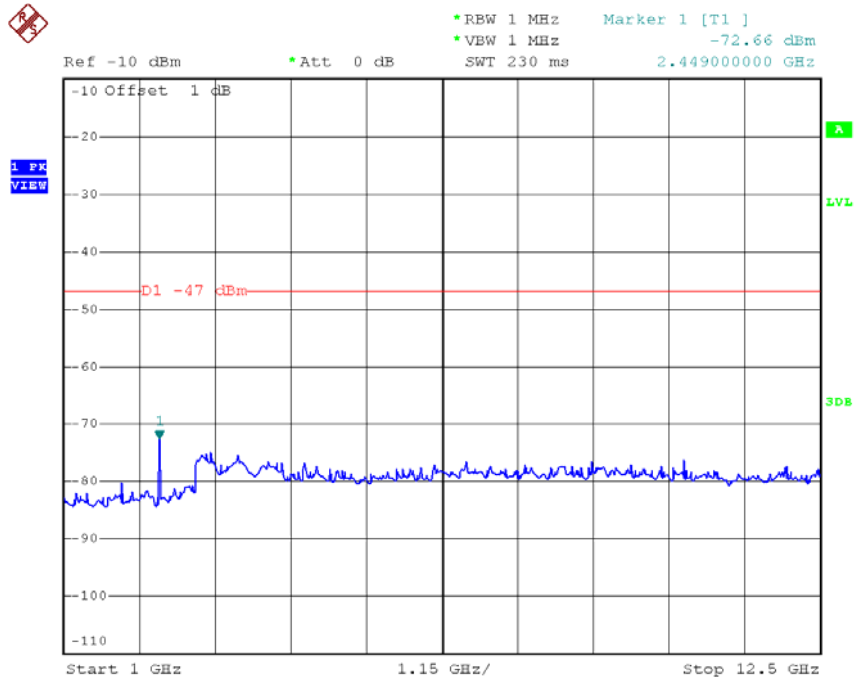

Date: 14.NOV.2015 14:37:23

Low Voltage

CH07- Frequency Band 6 (30 MHz \cong f < 1000 MHz)

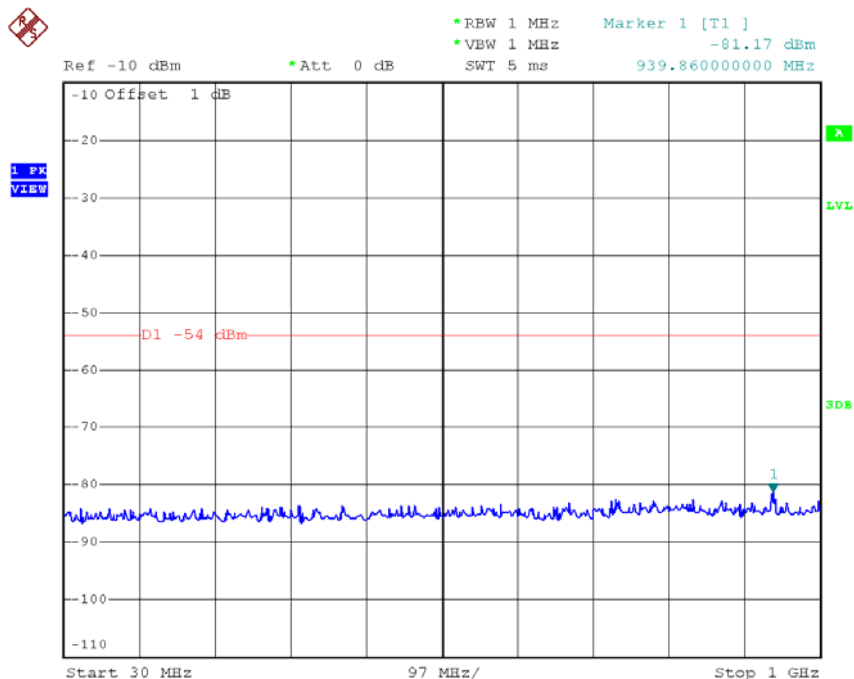

Date: 14.NOV.2015 14:49:57

Low Voltage

CH07- Frequency Band 7 (1000 MHz \cong f < 12.5 GHz)

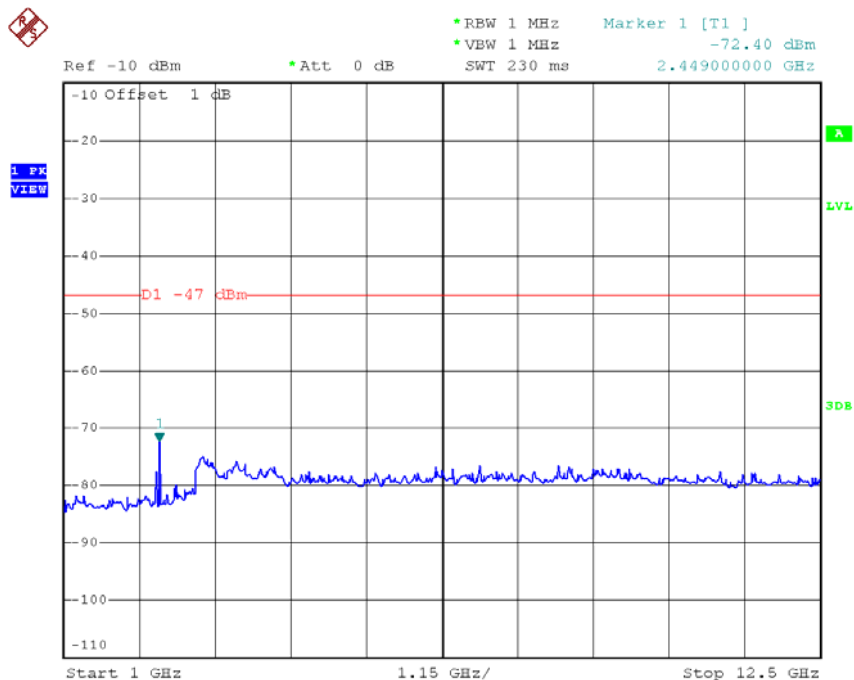

Date: 14.NOV.2015 14:38:35

Low Voltage

CH13- Frequency Band 6 (30 MHz \cong f < 1000 MHz)

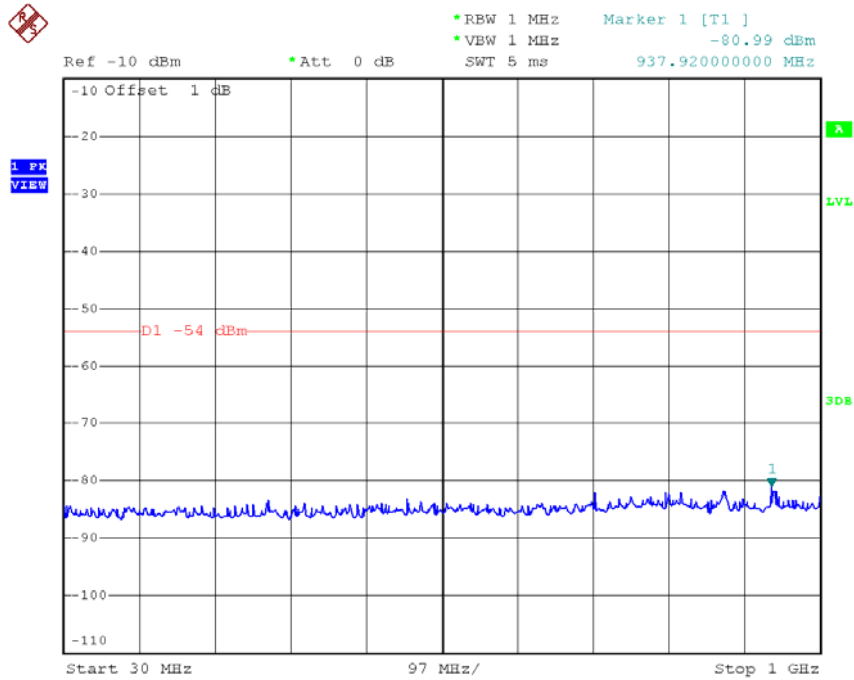

Date: 14.NOV.2015 14:50:08

Low Voltage

CH13- Frequency Band 7 (1000 MHz \cong f < 12.5 GHz)

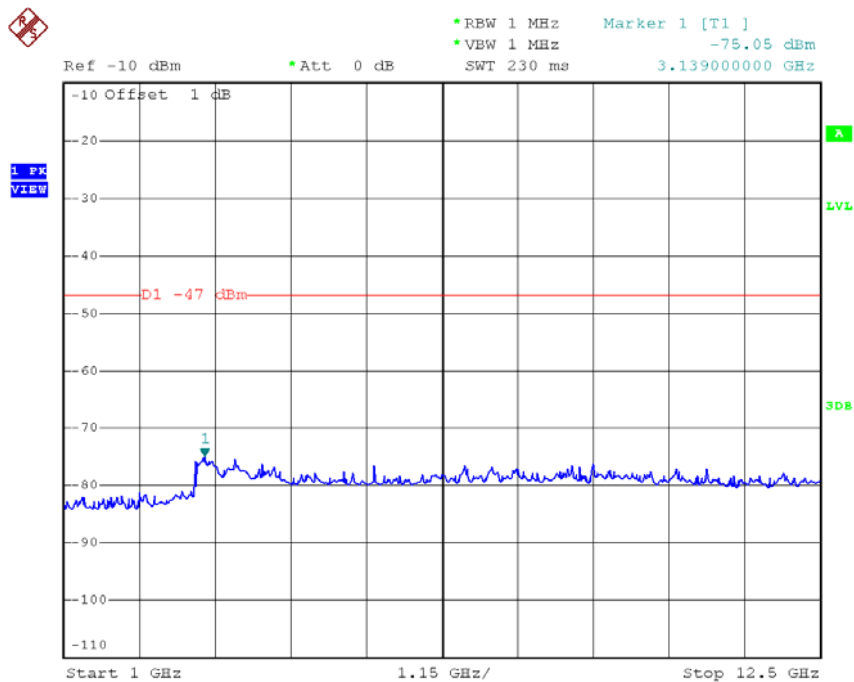

Date: 14.NOV.2015 14:38:59

Test Mode:	802.11n(HT20)/CH01,CH07,CH13
------------	------------------------------

Test Voltage		V	Normal Voltage			Remarks
Test Frequency		MHz	2412	2442	2472	Low/Mid/Low of test frequency range
Limitation of Collateral Emission of Receiver	※6	nW	0.0074	0.0108	0.0091	Limit \leq 4 nW (-54 dBm)
	※7	nW	0.0351	0.0337	0.0323	Limit \leq 20 nW (-47 dBm)

Test Voltage		V	High Voltage			Remarks
Test Frequency		MHz	2412	2442	2472	Low/Mid/Low of test frequency range
Limitation of Collateral Emission of Receiver	※6	nW	0.0080	0.0091	0.0081	Limit \leq 4 nW (-54 dBm)
	※7	nW	0.0343	0.0321	0.0313	Limit \leq 20 nW (-47 dBm)

Test Voltage		V	Low Voltage			Remarks
Test Frequency		MHz	2412	2442	2472	Low/Mid/Low of test frequency range
Limitation of Collateral Emission of Receiver	※6	nW	0.0079	0.0077	0.0090	Limit \leq 4 nW (-54 dBm)
	※7	nW	0.0372	0.0555	0.0283	Limit \leq 20 nW (-47 dBm)

Normal Voltage CH01- Frequency Band 6 (30 MHz \leq f < 1000 MHz)

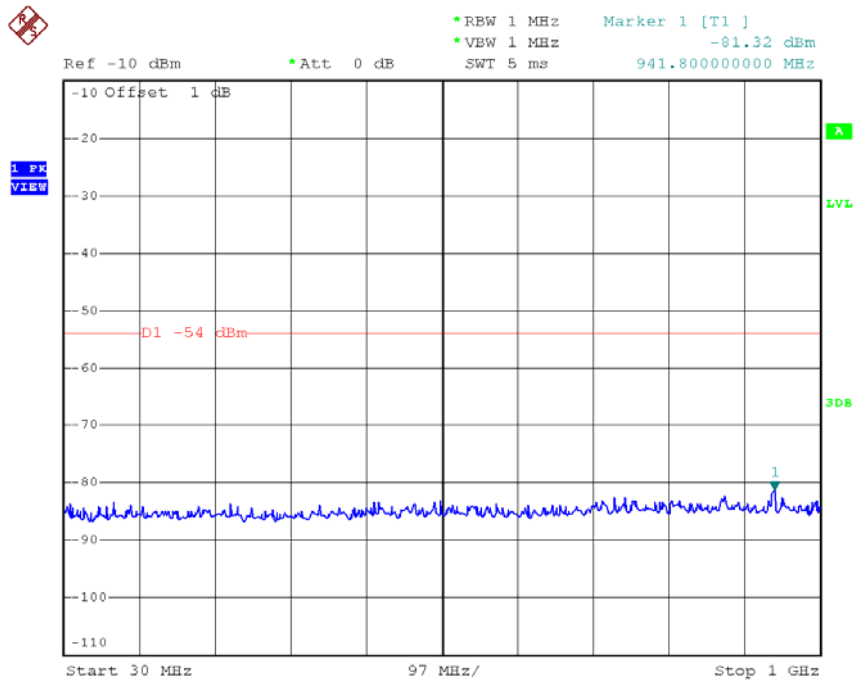

Date: 14.NOV.2015 14:45:31

Normal Voltage CH01- Frequency Band 7 (1000 MHz \leq f < 12.5 GHz)

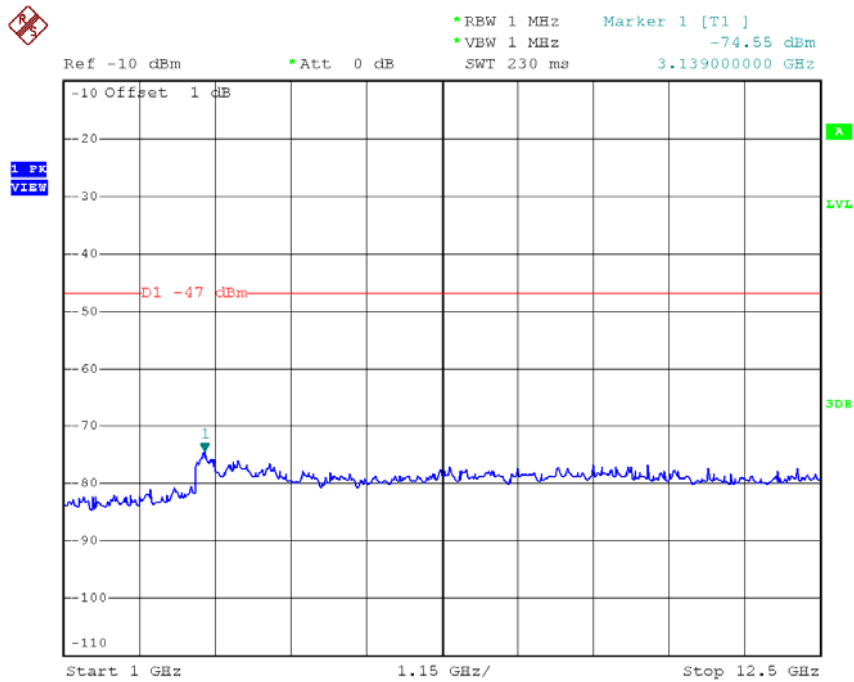

Date: 14.NOV.2015 14:32:27

Normal Voltage
CH07- Frequency Band 6 (30 MHz \cong f < 1000 MHz)

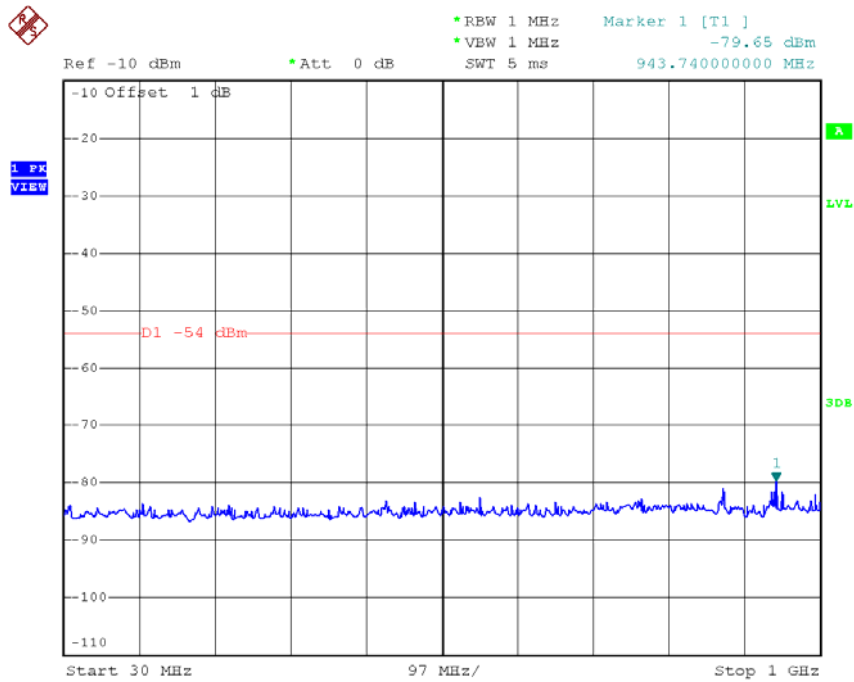

Date: 14.NOV.2015 14:45:42

Normal Voltage
CH07- Frequency Band 7 (1000 MHz \cong f < 12.5 GHz)

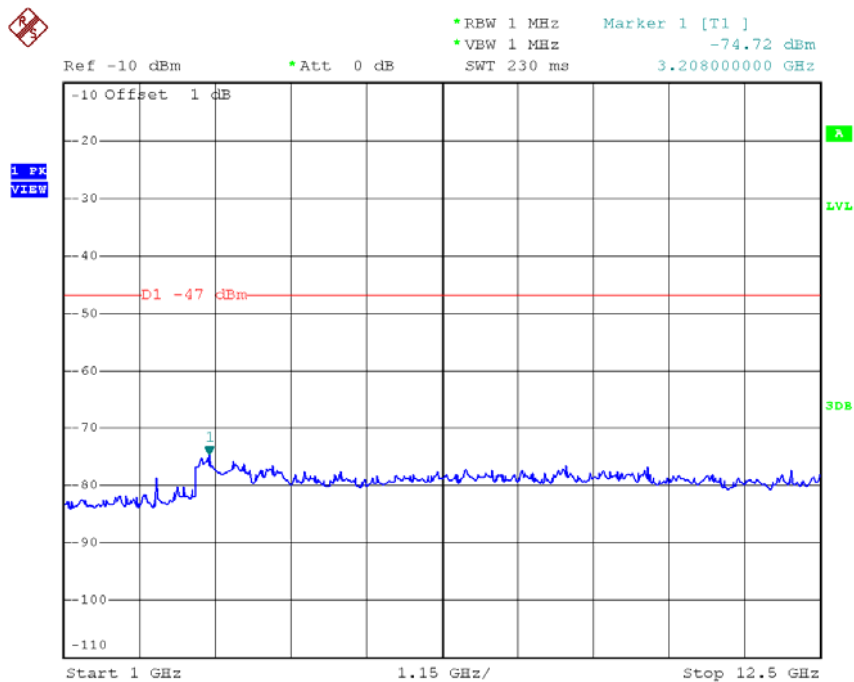

Date: 14.NOV.2015 14:32:54

High Voltage CH01- Frequency Band 6 (30 MHz \leq f < 1000 MHz)

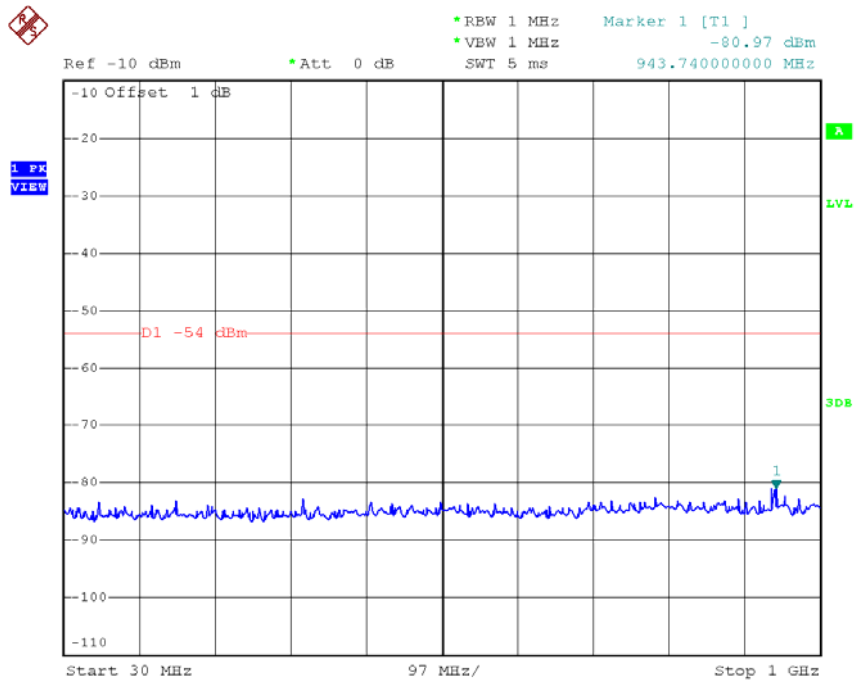

Date: 14.NOV.2015 14:47:58

High Voltage CH01- Frequency Band 7 (1000 MHz \leq f < 12.5 GHz)

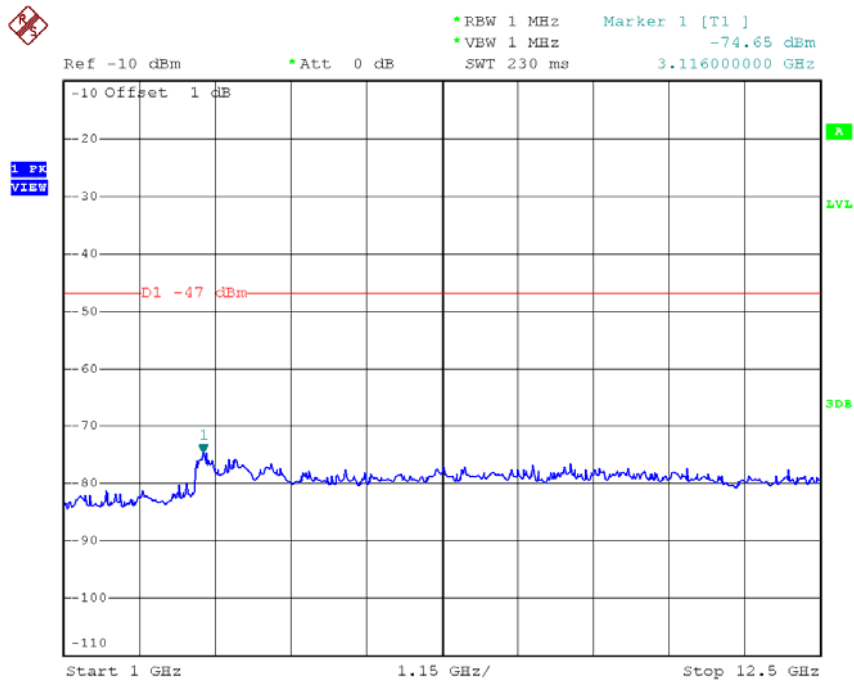

Date: 14.NOV.2015 14:28:47

High Voltage CH07- Frequency Band 6 (30 MHz \cong f < 1000 MHz)

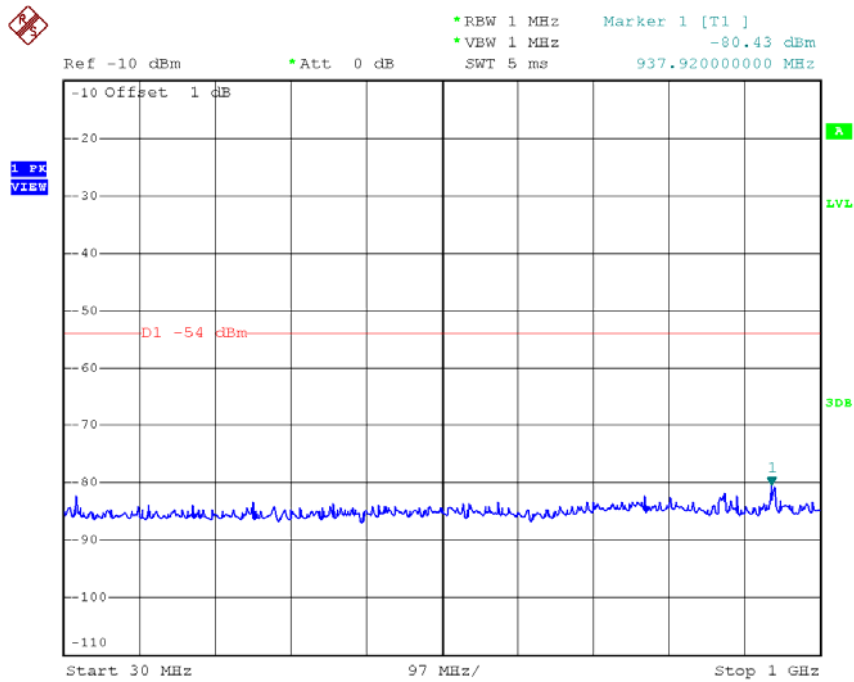

Date: 14.NOV.2015 14:48:16

High Voltage CH07- Frequency Band 7 (1000 MHz \cong f < 12.5 GHz)

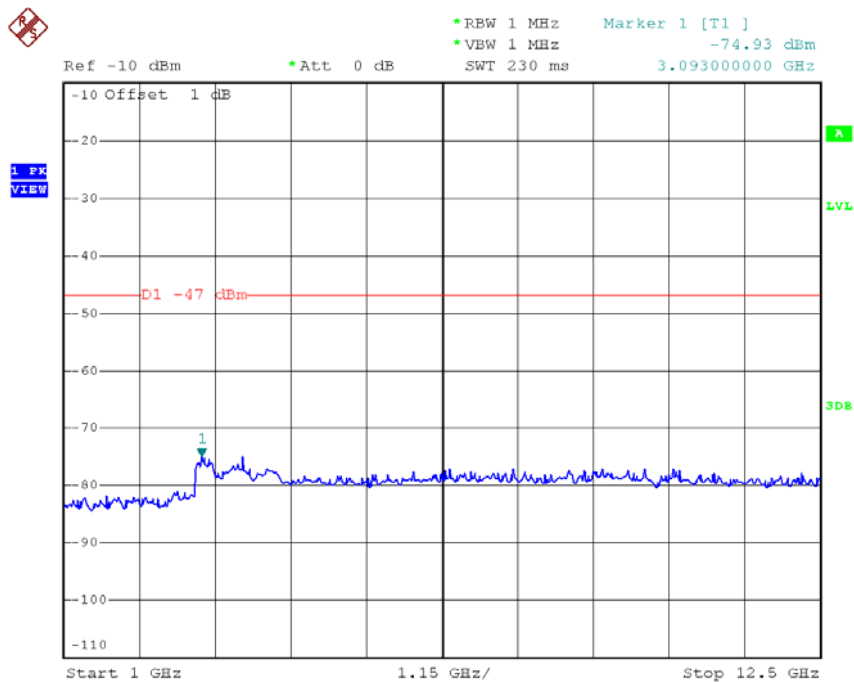

Date: 14.NOV.2015 14:29:14

High Voltage CH13- Frequency Band 6 (30 MHz \cong f < 1000 MHz)

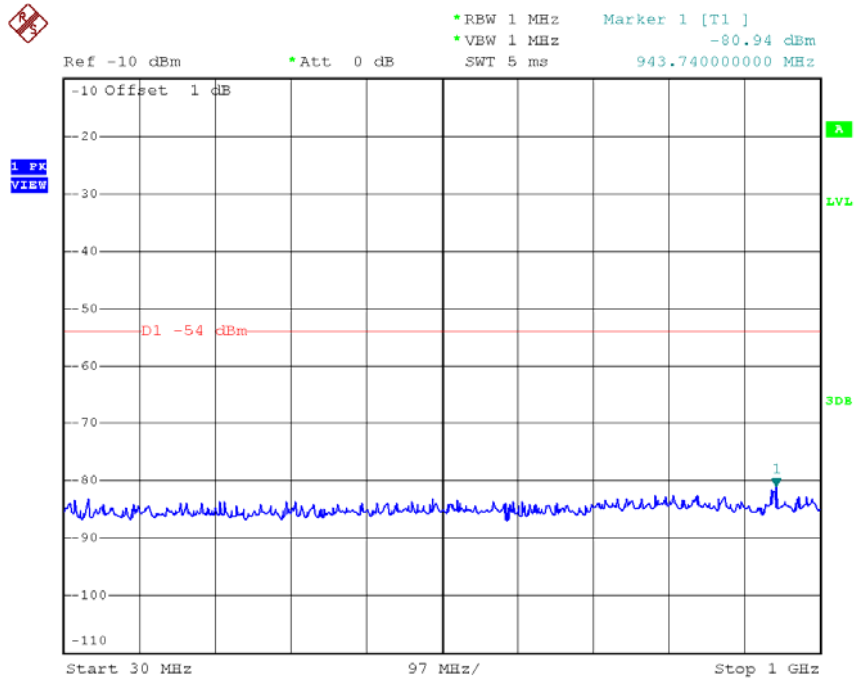

Date: 14.NOV.2015 14:48:28

High Voltage CH13- Frequency Band 7 (1000 MHz \cong f < 12.5 GHz)

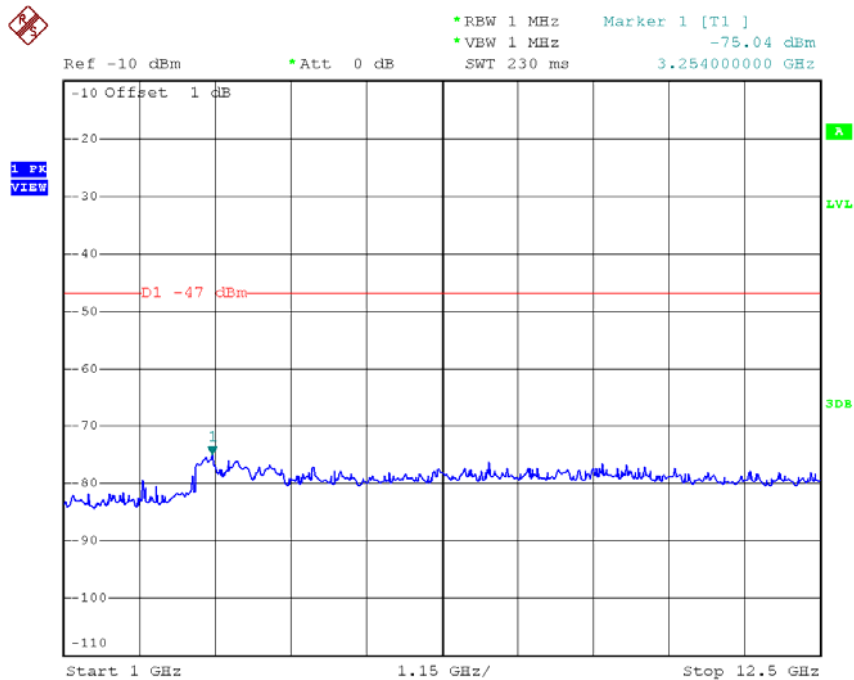

Date: 14.NOV.2015 14:29:38

Low Voltage
CH07- Frequency Band 6 (30 MHz \leq f < 1000 MHz)

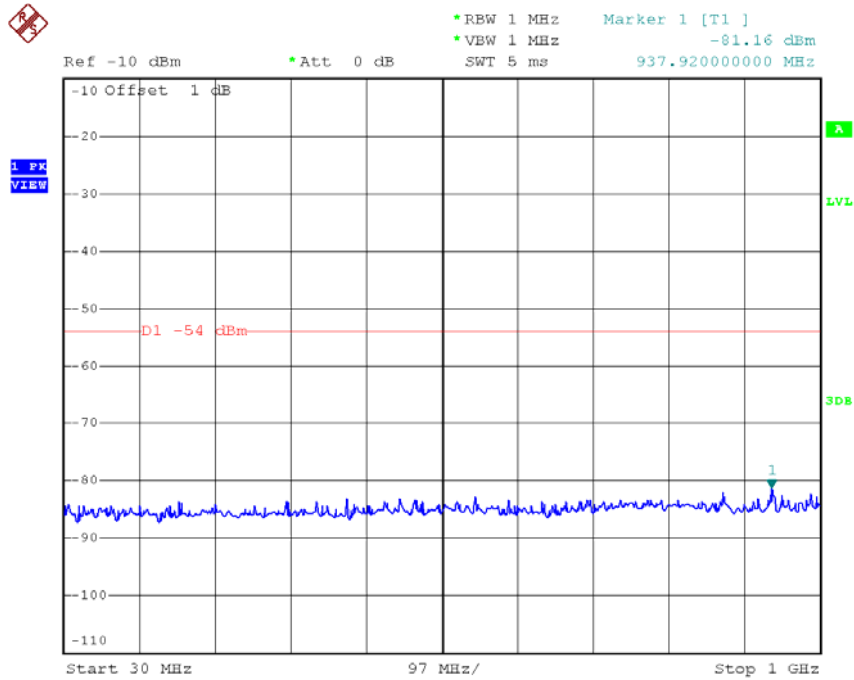

Date: 14.NOV.2015 14:50:31

Low Voltage
CH07- Frequency Band 7 (1000 MHz \leq f < 12.5 GHz)

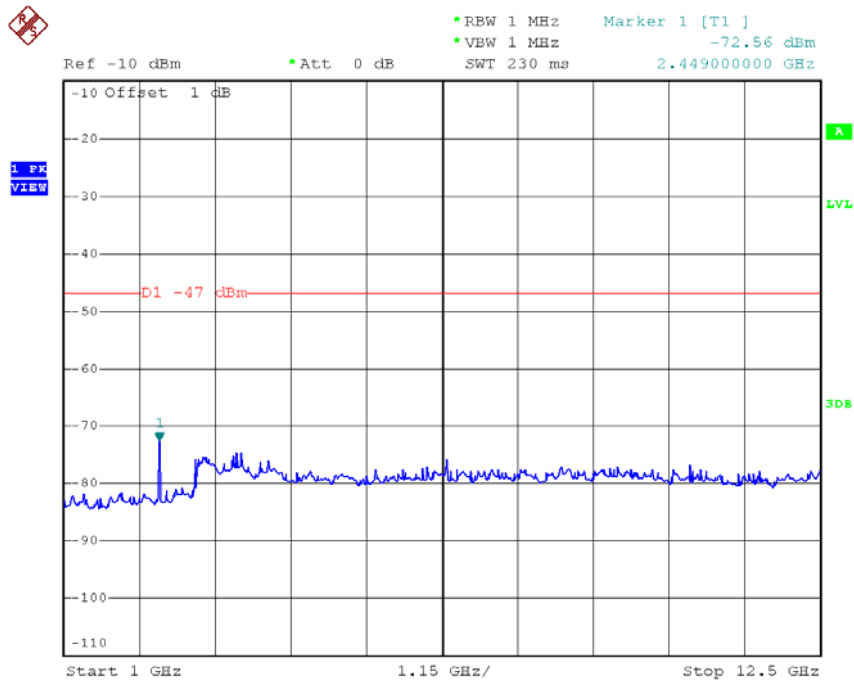

Date: 14.NOV.2015 14:40:03

