



BUREAU VERITAS

Test Report No.: RF200520W003-2



ACCREDITED
Certificate # 3939.01

FCC TEST REPORT (PART 24)

| | |
|------------|---|
| Applicant: | Particle Industries, Inc |
| Address: | 126 Post St, 4th floor, San Francisco, CA 94108 USA |

| | |
|--------------------------|---|
| Manufacturer or Supplier | Particle Industries, Inc |
| Address | 126 Post St, 4th floor, San Francisco, CA 94108 USA |
| Product | Tracker SoM LTE M1 |
| Brand Name | Particle |
| Model Name | T402M/T404M |
| FCC ID | 2AEMI-T40X |
| Date of tests | May. 21, 2020 ~ Jun. 09, 2020 |

The tests have been carried out according to the requirements of the following standard:

- FCC PART 24, Subpart E
- FCC PART 2
- ANSI/TIA/EIA-603-D
- ANSI/TIA/EIA-603-E
- ANSI C63.26-2015

CONCLUSION: The submitted sample was found to COMPLY with the test requirement

Prepared by Alex Chen
Engineer / Mobile Department

Approved by Luke Lu
Manager / Mobile Department

Date: Jun. 09, 2020

Date: Jun. 09, 2020

This report is governed by, and incorporates by reference, CPS Conditions of Service as posted at the date of issuance of this report at <http://www.bureauveritas.com/home/about-us/our-business/cps/about-us/terms-conditions> and is intended for your exclusive use. Any copying or replication of this report to or for any other person or entity, or use of our name or trademark, is permitted only with our prior written permission. This report sets forth our findings solely with respect to the test samples identified herein. The results set forth in this report are not indicative or representative of the quality or characteristics of the lot from which a test sample was taken or any similar or identical product unless specifically and expressly noted. Our report includes all of the tests requested by you and the results thereof based upon the information that you provided to us. Measurement uncertainty is only provided upon request for accredited tests. You have 60 days from date of issuance of this report to notify us of any material error or omission caused by our negligence or if you require measurement uncertainty; provided, however, that such notice shall be in writing and shall specifically address the issue you wish to raise. A failure to raise such issue within the prescribed time shall constitute your unqualified acceptance of the completeness of this report, the tests conducted and the correctness of the report contents.



TABLE OF CONTENTS

RELEASE CONTROL RECORD 4

1 SUMMARY OF TEST RESULTS 5

1.1 MEASUREMENT UNCERTAINTY 6

1.2 TEST SITE AND INSTRUMENTS 7

2 GENERAL INFORMATION 8

2.1 GENERAL DESCRIPTION OF EUT 8

2.2 CONFIGURATION OF SYSTEM UNDER TEST 12

2.3 DESCRIPTION OF SUPPORT UNITS 13

2.4 TEST ITEM AND TEST CONFIGURATION 13

2.5 EUT OPERATING CONDITIONS 14

2.6 GENERAL DESCRIPTION OF APPLIED STANDARDS 15

3 TEST TYPES AND RESULTS 16

3.1 OUTPUT POWER MEASUREMENT 16

3.1.1 LIMITS OF OUTPUT POWER MEASUREMENT 16

3.1.2 TEST PROCEDURES 16

3.1.3 TEST SETUP 17

3.1.4 TEST RESULTS 17

3.2 FREQUENCY STABILITY MEASUREMENT 31

3.2.1 LIMITS OF FREQUENCY STABILITY MEASUREMENT 31

3.2.2 TEST PROCEDURE 31

3.2.3 TEST SETUP 31

3.2.4 TEST RESULTS 32

3.3 OCCUPIED BANDWIDTH MEASUREMENT 33

3.3.1 TEST PROCEDURES 33

3.3.2 TEST SETUP 33

3.3.3 TEST RESULTS 33

3.4 BAND EDGE MEASUREMENT 34

3.4.1 LIMITS OF BAND EDGE MEASUREMENT 34

3.4.2 TEST SETUP 34

3.4.3 TEST PROCEDURES 35

3.4.4 TEST RESULTS 35

3.5 CONDUCTED SPURIOUS EMISSIONS 36

3.5.1 LIMITS OF CONDUCTED SPURIOUS EMISSIONS MEASUREMENT 36

3.5.2 TEST PROCEDURE 36

3.5.3 TEST SETUP 36

3.5.4 TEST RESULTS 36

3.6 RADIATED EMISSION MEASUREMENT 37

3.6.1 LIMITS OF RADIATED EMISSION MEASUREMENT 37

3.6.2 TEST PROCEDURES 37

3.6.3 DEVIATION FROM TEST STANDARD 37

3.6.4 TEST SETUP 38

3.6.5 TEST RESULTS 39

3.7 PEAK TO AVERAGE RATIO 85

3.7.1 LIMITS OF PEAK TO AVERAGE RATIO MEASUREMENT 85

3.7.2 TEST SETUP 85

3.7.3 TEST PROCEDURES 85

3.7.4 TEST RESULTS 85



4 INFORMATION ON THE TESTING LABORATORIES..... 86

5 APPENDIX A – MODIFICATIONS RECORDERS FOR ENGINEERING CHANGES TO THE EUT BY THE LAB 87



BUREAU
VERITAS

Test Report No.: RF200520W003-2

RELEASE CONTROL RECORD

| ISSUE NO. | REASON FOR CHANGE | DATE ISSUED |
|----------------|-------------------|---------------|
| RF200520W003-2 | Original release | Jun. 09, 2020 |



1 SUMMARY OF TEST RESULTS

The EUT has been tested according to the following specifications:

| APPLIED STANDARD: FCC Part 24 & Part 2 | | |
|--|-------------------------------------|------------|
| STANDARD SECTION | TEST TYPE | RESULT |
| 2.1046 24.232 | Equivalent Isotropic Radiated Power | Compliance |
| 2.1055 24.235 | Frequency Stability | See Note |
| 2.1049 24.238(b) | Occupied Bandwidth | See Note |
| 24.232(d) | Peak to average ratio | See Note |
| 24.238(b) | Band Edge Measurements | See Note |
| 2.1051 24.238 | Conducted Spurious Emissions | See Note |
| 2.1053 24.238 | Radiated Spurious Emissions | Compliance |

Note: Test data re-use from certified module BG96, BG96 MINIPCIE, more details please refer test report R1811A0536-R2 (FCC ID: XMR201707BG96).



1.1 MEASUREMENT UNCERTAINTY

Where relevant, the following measurement uncertainty levels have been estimated for tests performed on the EUT as specified in CISPR 16-4-2:

| MEASUREMENT | UNCERTAINTY |
|--|-----------------------|
| Frequency Stability | $\pm 76.97\text{Hz}$ |
| Radiated emissions & Radiated Power (30MHz~1GMHz) | $\pm 4.98\text{dB}$ |
| Radiated emissions & Radiated Power (1GMHz ~6GMHz) | $\pm 4.70\text{dB}$ |
| Radiated emissions (6GMHz ~18GMHz) | $\pm 4.60\text{dB}$ |
| Radiated emissions (18GMHz ~40GMHz) | $\pm 4.12\text{dB}$ |
| Conducted emissions | $\pm 4.01\text{dB}$ |
| Occupied Channel Bandwidth | $\pm 43.58\text{KHz}$ |
| Conducted Output power | $\pm 2.06\text{dB}$ |
| Band Edge Measurements | $\pm 4.70\text{dB}$ |
| Peak to average ratio | $\pm 0.76\text{dB}$ |

This uncertainty represents an expanded uncertainty expressed at approximately the 95% confidence level using a coverage factor of $k=2$.



1.2 TEST SITE AND INSTRUMENTS

| Equipment | Manufacturer | Model No. | Serial No. | Last Cal. | Next Cal. |
|---------------------------------------|--------------|-----------------------------|-----------------------------|-------------|-------------|
| MXE EMI Receiver | KEYSIGHT | N9038A-544 | MY54450026 | Feb. 26,20 | Feb. 25,21 |
| EXA Signal Analyzer | KEYSIGHT | N9010A-544 | MY54510355 | Jun. 24,19 | Jun. 23,20 |
| Bilog Antenna | ETS-LINDGREN | 3143B | 00161965 | Mar. 27,20 | Mar. 26,21 |
| Horn Antenna (1GHz-18GHz) | ETS-LINDGREN | 3117 | 00168692 | Mar. 27,20 | Mar. 26,21 |
| Horn Antenna (18GHz-40GHz) | N/A | QWH-SL-18-40-K-SG/QMS-00361 | 15433 | Nov. 24,19 | Nov. 23,20 |
| Radio Communication Analyzer | ANRITSU | MT8820C | 6201465426 | Feb. 27,20 | Feb. 26,21 |
| Signal Pre-Amplifier | EMSI | EMC 9135 | 980249 | Jun. 24,19 | Jun. 23,20 |
| Signal Pre-Amplifier | EMSI | EMC 012645B | 980257 | Jun. 24,19 | Jun. 23,20 |
| Signal Pre-Amplifier | EMSI | EMC 184045B | 980259 | Jun. 24,19 | Jun. 23,20 |
| 3m Semi-anechoic Chamber | ETS-LINDGREN | 9m*6m*6m | Euroshieldpn-CT0001143-1216 | May. 18,20 | May. 17,23 |
| Test Software | E3 | V 9.160323 | N/A | N/A | N/A |
| Test Software | ADT | ADT_Radiated_V7.6.15.9.2 | N/A | N/A | N/A |
| 10dB Attenuator | JFW/USA | 50HF-010-SMA | 1505 | Jun. 24,19 | Jun. 23,20 |
| Power Meter | Anritsu | ML2495A | 1506002 | Feb. 26,20 | Feb. 25,21 |
| Power Sensor | Anritsu | MA2411B | 1339352 | Feb. 26,20 | Feb. 25,21 |
| Humid & Temp Programmable Tester | Juyi | ITH-120-45-CP-AR | IAA1504-001 | Jun. 24,19 | Jun. 23,20 |
| MXG Analog Microwave Signal Generator | KEYSIGHT | N5183A | MY50143024 | Mar. 11,20 | Mar. 10,21 |
| Power Divider | MCLI/USA | PS2-15 | 24880 | Nov. 22, 19 | Nov. 21, 20 |

- NOTE:**
1. The calibration interval of the above test instruments is 12 months or 36 months and the calibrations are traceable to CEPREI/CHINA, GRGT/CHINA and NIM/CHINA.
 2. The test was performed in 3m Semi-anechoic Chamber and RF Oven Room.
 3. The horn antenna is used only for the measurement of emission frequency above 1GHz if tested.
 4. The FCC Site Registration No. is 525120; The Designation No. is CN1171.



2 GENERAL INFORMATION

2.1 GENERAL DESCRIPTION OF EUT

| | | |
|---|--|-----------------------|
| PRODUCT | Tracker SoM LTE M1 | |
| BRAND NAME | Particle | |
| MODEL NAME | T402M/T404M | |
| POWER SUPPLY | Li+ PIN: DC +3.3V--4.3V or Vusb PIN: DC +4.35V--5.5V or Vin PIN: DC +3.9V--17V | |
| MODULATION TYPE | GSM, GPRS: GMSK EDGE:8PSK LTE CAT-M1: QPSK, 16QAM | |
| FREQUENCY RANGE | GSM, GPRS, EDGE | 1850.2MHz ~ 1909.8MHz |
| | LTE Band 2 Channel Bandwidth: 1.4MHz | 1850.7MHz ~ 1909.3MHz |
| | LTE Band 2 Channel Bandwidth: 3MHz | 1851.5MHz ~ 1908.5MHz |
| | LTE Band 2 Channel Bandwidth: 5MHz | 1852.5MHz ~ 1907.5MHz |
| | LTE Band 2 Channel Bandwidth: 10MHz | 1855.0MHz ~ 1905.0MHz |
| | LTE Band 2 Channel Bandwidth: 15MHz | 1857.5MHz ~ 1902.5MHz |
| | LTE Band 2 Channel Bandwidth: 20MHz | 1860.0MHz ~ 1900.0MHz |
| | LTE Band 25 Channel Bandwidth: 1.4MHz | 1850.7MHz ~ 1914.3MHz |
| | LTE Band 25 Channel Bandwidth: 3MHz | 1851.5MHz ~ 1913.5MHz |
| | LTE Band 25 Channel Bandwidth: 5MHz | 1852.5MHz ~ 1912.5MHz |
| | LTE Band 25 Channel Bandwidth: 10MHz | 1855.0MHz ~ 1910.0MHz |
| | LTE Band 25 Channel Bandwidth: 15MHz | 1857.5MHz ~ 1907.5MHz |
| | LTE Band 25 Channel Bandwidth: 20MHz | 1860.0MHz ~ 1905.0MHz |
| | MAX. EIRP POWER | GSM |
| EDGE | | 800mW |
| LTE Band 2 Channel Bandwidth: 1.4MHz | | 562mW |
| LTE Band 2 Channel Bandwidth: 3MHz | | 581mW |



| | | |
|---|--|---------------------------------|
| | LTE Band 2 Channel Bandwidth: 5MHz | 577mW |
| | LTE Band 2 Channel Bandwidth: 10MHz | 579mW |
| | LTE Band 2 Channel Bandwidth: 15MHz | 577mW |
| | LTE Band 2 Channel Bandwidth: 20MHz | 570mW |
| | LTE Band 25 Channel Bandwidth: 1.4MHz | 612mW |
| | LTE Band 25 Channel Bandwidth: 3MHz | 615mW |
| | LTE Band 25 Channel Bandwidth: 5MHz | 675mW |
| | LTE Band 25 Channel Bandwidth: 10MHz | 676mW |
| | LTE Band 25 Channel Bandwidth: 15MHz | 671mW |
| | LTE Band 25 Channel Bandwidth: 20MHz | 659mW |
| | EMISSION DESIGNATOR | GSM |
| EDGE | | 248KG7W |
| LTE Band 2 Channel Bandwidth: 1.4MHz | | QPSK: 1M11G7D 16QAM: 948KW7D |
| LTE Band 2 Channel Bandwidth: 3MHz | | QPSK: 1M16G7D 16QAM: 985KW7D |
| LTE Band 2 Channel Bandwidth: 5MHz | | QPSK: 1M17G7D 16QAM: 1M01W7D |
| LTE Band 2 Channel Bandwidth: 10MHz | | QPSK: 1M19G7D 16QAM: 1M19W7D |
| LTE Band 2 Channel Bandwidth: 15MHz | | QPSK: 1M22G7D 16QAM: 1M90W7D |
| LTE Band 2 Channel Bandwidth: 20MHz | | QPSK: 1M25G7D 16QAM: 1M15W7D |



| | | |
|----------------------------|--|---------------------------------|
| EMISSION DESIGNATOR | LTE Band 25 Channel Bandwidth: 1.4MHz | QPSK: 1M11G7D 16QAM: 951KW7D |
| | LTE Band 25 Channel Bandwidth: 3MHz | QPSK: 1M16G7D 16QAM: 992KW7D |
| | LTE Band 25 Channel Bandwidth: 5MHz | QPSK: 1M14G7D 16QAM: 975KW7D |
| | LTE Band 25 Channel Bandwidth: 10MHz | QPSK: 1M18G7D 16QAM: 1M05W7D |
| | LTE Band 25 Channel Bandwidth: 15MHz | QPSK: 1M20G7D 16QAM: 1M06W7D |
| | LTE Band 25 Channel Bandwidth: 20MHz | QPSK: 1M21G7D 16QAM: 1M11W7D |
| ANTENNA TYPE | External Antenna with 3.77dBi gain for GSM 1900/LTE Band 2/LTE Band 25 | |
| HW VERSION | V1.0 | |
| SW VERSION | V1.5.4 | |
| I/O PORTS | Refer to user's manual | |
| CABLE SUPPLIED | N/A | |



NOTE:

1. For a more detailed features description, please refer to the manufacturer's specifications or the user's manual.
2. The schematic and PCB of the two models T402M and T404M used by our company for the certification is completely the same ,and the HW&SW used is the same. Because the product is sold in different market using different models eSIM, different models are named. the differences are as follows:T402M uses eSIM of Kore.T404M uses eSIM of Twilio.
3. The EUT incorporates a SISO function. Physically, the EUT provides one completed transmitter and one receiver.

| MODULATION MODE | TX FUNCTION |
|-----------------|-------------------|
| GSM/GPRS/EDGE | 1TX/1RX diversity |
| LTE | 1TX/1RX diversity |

4. For the test results, the EUT had been tested with all conditions. But only the worst case was shown in test report.



2.2 CONFIGURATION OF SYSTEM UNDER TEST

FOR RADIATION EMISSION

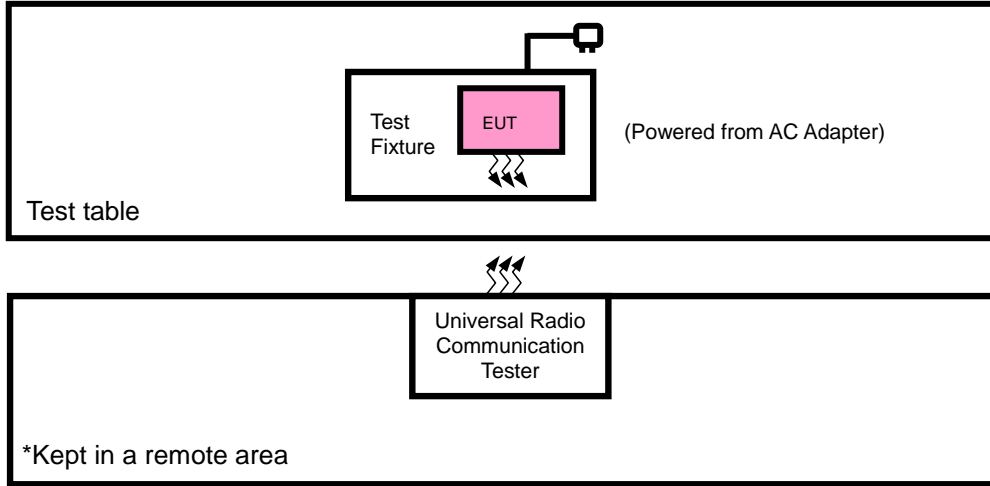



2.3 DESCRIPTION OF SUPPORT UNITS

The EUT has been tested as an independent unit together with other necessary accessories or support units. The following support units or accessories were used to form a representative test configuration during the tests.

| NO. | PRODUCT | BRAND | MODEL NO. | SERIAL NO. | FCC ID |
|-----|-----------|----------|-----------|------------|--------|
| 1 | DC source | LONG WEI | PS-6403D | 010934269 | N/A |

| NO. | SIGNAL CABLE DESCRIPTION OF THE ABOVE SUPPORT UNITS |
|-----|---|
| 1 | DC Line: Unshielded, Detachable 1.8m |

2.4 TEST ITEM AND TEST CONFIGURATION

Pre-Scan has been conducted to determine the worst-case mode from all possible combinations between available modulations, data rates, XYZ axis and antenna ports

The worst case in EIRP and radiated emission was found when positioned on X-plane for GSM/EDGE / LTE. Following channel(s) was (were) selected for the final test as listed below:

| EUT CONFIGURE MODE | DESCRIPTION |
|--------------------|---------------------------------|
| - | EUT + with GSM/EDGE or LTE link |
| - | EUT + with GSM/EDGE or LTE link |

GSM MODE

| TEST ITEM | AVAILABLE CHANNEL | TESTED CHANNEL | MODE |
|-------------------|-------------------|----------------|-----------|
| EIRP | 512 to 810 | 512, 661, 810 | GSM, EDGE |
| RADIATED EMISSION | 512 to 810 | 512, 661, 810 | GSM, EDGE |

**LTE BAND 2**

| TEST ITEM | AVAILABLE CHANNEL | TESTED CHANNEL | CHANNEL BANDWIDTH | MODULATION | MODE |
|-------------------|-------------------|---------------------|-------------------|------------|--------------------|
| EIRP | 18607 to 19193 | 18607, 18900, 19193 | 1.4MHz | QPSK,16QAM | 1 RB / 0 RB Offset |
| | 18615 to 19185 | 18615, 18900, 19185 | 3MHz | QPSK,16QAM | 1 RB / 0 RB Offset |
| | 18625 to 19175 | 18625, 18900, 19175 | 5MHz | QPSK,16QAM | 1 RB / 0 RB Offset |
| | 18650 to 19150 | 18650, 18900, 19150 | 10MHz | QPSK,16QAM | 1 RB / 0 RB Offset |
| | 18675 to 19125 | 18675, 18900, 19125 | 15MHz | QPSK,16QAM | 1 RB / 0 RB Offset |
| | 18700 to 19100 | 18700, 18900, 19100 | 20MHz | QPSK,16QAM | 1 RB / 0 RB Offset |
| RADIATED EMISSION | 18607 to 19193 | 18900 | 1.4MHz | QPSK | 1 RB / 0 RB Offset |
| | 18615 to 19185 | 18900 | 3MHz | QPSK | 1 RB / 0 RB Offset |
| | 18625 to 19175 | 18900 | 5MHz | QPSK | 1 RB / 0 RB Offset |
| | 18650 to 19150 | 18900 | 10MHz | QPSK | 1 RB / 0 RB Offset |
| | 18675 to 19125 | 18675, 18900, 19125 | 15MHz | QPSK | 1 RB / 0 RB Offset |
| | 18700 to 19100 | 18900 | 20MHz | QPSK | 1 RB / 0 RB Offset |

LTE BAND 25

| TEST ITEM | AVAILABLE CHANNEL | TESTED CHANNEL | CHANNEL BANDWIDTH | MODULATION | MODE |
|-------------------|-------------------|---------------------|-------------------|------------|--------------------|
| EIRP | 26047 to 26683 | 26047, 26365, 26683 | 1.4MHz | QPSK,16QAM | 2 RB / 0 RB Offset |
| | 26055 to 26675 | 26055, 26365, 26675 | 3MHz | QPSK,16QAM | 2 RB / 0 RB Offset |
| | 26065 to 26665 | 26065, 26365, 26665 | 5MHz | QPSK,16QAM | 2 RB / 0 RB Offset |
| | 26090 to 26640 | 26090, 26365, 26640 | 10MHz | QPSK,16QAM | 2 RB / 0 RB Offset |
| | 26115 to 26615 | 26115, 26365, 26615 | 15MHz | QPSK,16QAM | 2 RB / 0 RB Offset |
| | 26140 to 26590 | 26140, 26365, 26590 | 20MHz | QPSK,16QAM | 2 RB / 0 RB Offset |
| RADIATED EMISSION | 26047 to 26683 | 26365 | 1.4MHz | QPSK | 2 RB / 0 RB Offset |
| | 26055 to 26675 | 26055, 26365, 26675 | 3MHz | QPSK | 2 RB / 0 RB Offset |
| | 26065 to 26665 | 26365 | 5MHz | QPSK | 2 RB / 0 RB Offset |
| | 26090 to 26640 | 26365 | 10MHz | QPSK | 2 RB / 0 RB Offset |
| | 26115 to 26615 | 26365 | 15MHz | QPSK | 2 RB / 0 RB Offset |
| | 26140 to 26590 | 26365 | 20MHz | QPSK | 2 RB / 0 RB Offset |

TEST CONDITION:

| TEST ITEM | ENVIRONMENTAL CONDITIONS | INPUT POWER | TESTED BY |
|-------------------|--------------------------|-------------|-----------|
| EIRP | 25deg. C, 57%RH | DC 5V | Tony |
| RADIATED EMISSION | 23deg. C, 70%RH | DC 5V | Tony |

2.5 EUT OPERATING CONDITIONS

The EUT makes a call to the communication simulator. The communication simulator station system controlled a EUT to export maximum output power under transmission mode and specific channel frequency



2.6 GENERAL DESCRIPTION OF APPLIED STANDARDS

The EUT is a RF product. According to the specifications of the manufacturer, it must comply with the requirements of the following standards:

FCC 47 CFR Part 2

FCC 47 CFR Part 24

KDB 971168 D01 Power Meas License Digital Systems v03r01

ANSI/TIA/EIA-603-D

ANSI/TIA/EIA-603-E

ANSI C63.26-2015

NOTE: All test items have been performed and recorded as per the above standards.



3 TEST TYPES AND RESULTS

3.1 OUTPUT POWER MEASUREMENT

3.1.1 LIMITS OF OUTPUT POWER MEASUREMENT

Mobile and portable stations are limited to 2 watts EIRP.

3.1.2 TEST PROCEDURES

EIRP MEASUREMENT:

Per KDB 971168 D01 Power Meas License Digital Systems v03r01 or subclause 5.2.5.5 of ANSI C63.26-2015, the relevant equation for determining the ERP or EIRP from the conducted RF output power measured using the guidance provided above is:

$$\text{ERP or EIRP} = P_{\text{Meas}} + G_{\text{T}} - L_{\text{C}}$$

Where:

ERP or EIRP = effective radiated power or equivalent isotropically radiated power, respectively

(expressed in the same units as P_{Meas} , typically dBW or dBm);

P_{Meas} = measured transmitter output power or PSD, in dBm or dBW;

G_{T} = gain of the transmitting antenna, in dBd (ERP) or dBi (EIRP);

L_{C} = signal attenuation in the connecting cable between the transmitter and antenna, in dB.

CONDUCTED POWER MEASUREMENT:

The EUT was set up for the maximum power with WCDMA link data modulation and link up with simulator. Set the EUT to transmit under low, middle and high channel and record the power level shown on simulator.



3.1.3 TEST SETUP

EIRP / ERP Measurement:

CONDUCTED POWER MEASUREMENT:



3.1.4 TEST RESULTS

CONDUCTED OUTPUT POWER (dBm)

| Band Channel | GSM1900 | | | GSM1900 Max. Tune-up Power |
|-----------------------|---------------|-------------|---------------|-------------------------------------|
| | 512 1850.2 | 661 1880 | 810 1909.8 | |
| Frequency | | | | |
| GPRS (GMSK, 1Tx-slot) | 29.81 | 29.85 | 29.95 | 30.0 |
| GPRS (GMSK, 2Tx-slot) | 29.71 | 29.66 | 29.82 | 30.0 |
| GPRS (GMSK, 3Tx-slot) | 29.62 | 29.62 | 29.72 | 30.0 |
| GPRS (GMSK, 4Tx-slot) | 29.46 | 29.45 | 29.56 | 30.0 |
| EDGE (GMSK, 1Tx-slot) | 25.18 | 25.00 | 25.26 | 25.5 |
| EDGE (GMSK, 2Tx-slot) | 25.03 | 24.89 | 25.10 | 25.5 |
| EDGE (GMSK, 3Tx-slot) | 24.96 | 24.73 | 24.94 | 25.0 |
| EDGE (GMSK, 4Tx-slot) | 24.74 | 24.43 | 24.78 | 25.0 |



LTE Band 2

| Band/BW | Modulation | RB Size | RB Offset | Low CH 18607 | Mid CH 18900 | High CH 19193 | Tune Up |
|---------|------------|---------|-----------|-------------------------|-----------------------|-------------------------|---------|
| | | | | Frequency 1850.7 MHz | Frequency 1880 MHz | Frequency 1909.3 MHz | |
| 2/ 1.4 | QPSK | 1 | 0 | 23.32 | 23.25 | 23.33 | 23.5 |
| | | 1 | 5 | 23.38 | 23.16 | 23.37 | |
| | | 3 | 0 | 23.41 | 23.27 | 23.36 | 23.5 |
| | | 3 | 3 | 23.32 | 23.18 | 23.34 | |
| | | 6 | 0 | 23.33 | 23.31 | 23.24 | 23.5 |
| | 16QAM | 1 | 0 | 22.75 | 22.75 | 22.73 | 23.5 |
| | | 1 | 5 | 22.81 | 22.76 | 22.79 | |
| | | 3 | 0 | 23.14 | 23.03 | 23.16 | 23.5 |
| | | 3 | 3 | 23.18 | 23.09 | 23.15 | |
| | | 6 | 0 | 23.28 | 23.31 | 23.29 | 23.5 |

| Band/BW | Modulation | RB Size | RB Offset | Low CH 18615 | Mid CH 18900 | High CH 19185 | Tune Up |
|---------|------------|---------|-----------|-------------------------|-----------------------|-------------------------|---------|
| | | | | Frequency 1851.5 MHz | Frequency 1880 MHz | Frequency 1908.5 MHz | |
| 2/ 3 | QPSK | 1 | 0 | 23.34 | 23.27 | 23.32 | 23.5 |
| | | 1 | 5 | 23.34 | 23.17 | 23.37 | |
| | | 3 | 0 | 23.37 | 23.27 | 23.36 | 23.5 |
| | | 3 | 3 | 23.31 | 23.21 | 23.34 | |
| | | 6 | 0 | 23.26 | 23.31 | 23.26 | 23.5 |
| | 16QAM | 1 | 0 | 22.72 | 22.81 | 22.76 | 23.5 |
| | | 1 | 5 | 22.78 | 22.79 | 22.77 | |
| | | 3 | 0 | 23.17 | 23.03 | 23.16 | 23.5 |
| | | 3 | 3 | 23.14 | 23.10 | 23.15 | |
| | | 6 | 0 | 23.33 | 23.26 | 23.32 | 23.5 |



| Band/BW | Modulation | RB Size | RB Offset | Low CH 18625 | Mid CH 18900 | High CH 19175 | Tune Up |
|---------|------------|---------|-----------|-------------------------|-----------------------|-------------------------|---------|
| | | | | Frequency 1852.5 MHz | Frequency 1880 MHz | Frequency 1907.5 MHz | |
| 2/ 5 | QPSK | 1 | 0 | 23.35 | 23.22 | 23.33 | 23.5 |
| | | 1 | 5 | 23.39 | 23.14 | 23.37 | |
| | | 3 | 0 | 23.38 | 23.26 | 23.40 | 23.5 |
| | | 3 | 3 | 23.34 | 23.21 | 23.31 | |
| | | 6 | 0 | 23.26 | 23.32 | 23.27 | 23.5 |
| | 16QAM | 1 | 0 | 22.73 | 22.77 | 22.76 | 23.5 |
| | | 1 | 5 | 22.75 | 22.82 | 22.76 | |
| | | 3 | 0 | 23.17 | 23.03 | 23.15 | 23.5 |
| | | 3 | 3 | 23.14 | 23.08 | 23.12 | |
| | | 6 | 0 | 23.30 | 23.30 | 23.28 | 23.5 |

| Band/BW | Modulation | RB Size | RB Offset | Low CH 18650 | Mid CH 18900 | High CH 19150 | Tune Up |
|---------|------------|---------|-----------|-----------------------|-----------------------|-----------------------|---------|
| | | | | Frequency 1855 MHz | Frequency 1880 MHz | Frequency 1905 MHz | |
| 2/ 10 | QPSK | 1 | 0 | 23.32 | 23.25 | 23.33 | 23.5 |
| | | 1 | 5 | 23.39 | 23.14 | 23.38 | |
| | | 3 | 0 | 23.35 | 23.30 | 23.36 | 23.5 |
| | | 3 | 3 | 23.35 | 23.20 | 23.34 | |
| | | 6 | 0 | 23.32 | 23.26 | 23.27 | 23.5 |
| | 16QAM | 1 | 0 | 22.73 | 22.74 | 22.72 | 23.5 |
| | | 1 | 5 | 22.80 | 22.78 | 22.79 | |
| | | 3 | 0 | 23.17 | 23.04 | 23.12 | 23.5 |
| | | 3 | 3 | 23.16 | 23.06 | 23.18 | |
| | | 6 | 0 | 23.34 | 23.24 | 23.33 | 23.5 |



| Band/BW | Modulation | RB Size | RB Offset | Low CH 18675 | Mid CH 18900 | High CH 19125 | Tune Up |
|---------|------------|---------|-----------|-------------------------|-----------------------|-------------------------|---------|
| | | | | Frequency 1857.5 MHz | Frequency 1880 MHz | Frequency 1902.5 MHz | |
| 2/ 15 | QPSK | 1 | 0 | 23.39 | 23.25 | 23.30 | 23.5 |
| | | 1 | 5 | 23.37 | 23.19 | 23.33 | |
| | | 3 | 0 | 23.41 | 23.33 | 23.37 | 23.5 |
| | | 3 | 3 | 23.32 | 23.21 | 23.35 | |
| | | 6 | 0 | 23.33 | 23.31 | 23.27 | 23.5 |
| | 16QAM | 1 | 0 | 22.77 | 22.81 | 22.72 | 23.5 |
| | | 1 | 5 | 22.79 | 22.79 | 22.79 | |
| | | 3 | 0 | 23.13 | 23.09 | 23.14 | 23.5 |
| | | 3 | 3 | 23.20 | 23.06 | 23.19 | |
| | | 6 | 0 | 23.28 | 23.28 | 23.29 | 23.5 |

| Band/BW | Modulation | RB Size | RB Offset | Low CH 18700 | Mid CH 18900 | High CH 19100 | Tune Up |
|---------|------------|---------|-----------|-----------------------|-----------------------|-----------------------|---------|
| | | | | Frequency 1860 MHz | Frequency 1880 MHz | Frequency 1900 MHz | |
| 2/ 20 | QPSK | 1 | 0 | 23.40 | 23.29 | 23.38 | 23.5 |
| | | 1 | 5 | 23.41 | 23.22 | 23.39 | |
| | | 3 | 0 | 23.43 | 23.34 | 23.41 | 23.5 |
| | | 3 | 3 | 23.38 | 23.26 | 23.36 | |
| | | 6 | 0 | 23.34 | 23.33 | 23.32 | 23.5 |
| | 16QAM | 1 | 0 | 22.80 | 22.82 | 22.78 | 23.5 |
| | | 1 | 5 | 22.83 | 22.84 | 22.81 | |
| | | 3 | 0 | 23.19 | 23.11 | 23.17 | 23.5 |
| | | 3 | 3 | 23.22 | 23.14 | 23.20 | |
| | | 6 | 0 | 23.36 | 23.32 | 23.34 | 23.5 |



LTE Band 25

| Band/BW | Modulation | RB Size | RB Offset | Low CH 26047 | Mid CH 26365 | High CH 26683 | Tune Up |
|---------|------------|---------|-----------|-------------------------|-------------------------|-------------------------|------------|
| | | | | Frequency 1850.7 MHz | Frequency 1882.5 MHz | Frequency 1914.3 MHz | |
| 25/ 1.4 | QPSK | 1 | 0 | 23.85 | 23.86 | 24.03 | 24.5 |
| | | 1 | 5 | 23.83 | 23.77 | 23.99 | |
| | | 3 | 0 | 23.88 | 23.80 | 24.00 | 24.5 |
| | | 3 | 3 | 23.78 | 23.73 | 23.97 | |
| | | 6 | 0 | 23.91 | 23.87 | 23.99 | 24.5 |
| | 16QAM | 1 | 0 | 23.25 | 23.20 | 23.40 | 24.5 |
| | | 1 | 5 | 23.26 | 23.17 | 23.41 | |
| | | 3 | 0 | 23.56 | 23.50 | 23.75 | 24.5 |
| | | 3 | 3 | 23.52 | 23.48 | 23.66 | |
| | | 6 | 0 | 23.78 | 23.82 | 23.96 | 24.5 |

| Band/BW | Modulation | RB Size | RB Offset | Low CH 26055 | Mid CH 26365 | High CH 26675 | Tune Up |
|---------|------------|---------|-----------|-------------------------|-------------------------|-------------------------|------------|
| | | | | Frequency 1851.5 MHz | Frequency 1882.5 MHz | Frequency 1913.5 MHz | |
| 25/ 3 | QPSK | 1 | 0 | 23.87 | 23.88 | 24.02 | 24.5 |
| | | 1 | 5 | 23.79 | 23.78 | 23.99 | |
| | | 3 | 0 | 23.84 | 23.80 | 24.00 | 24.5 |
| | | 3 | 3 | 23.77 | 23.76 | 23.97 | |
| | | 6 | 0 | 23.84 | 23.87 | 24.01 | 24.5 |
| | 16QAM | 1 | 0 | 23.22 | 23.26 | 23.43 | 24.5 |
| | | 1 | 5 | 23.23 | 23.20 | 23.39 | |
| | | 3 | 0 | 23.59 | 23.50 | 23.75 | 24.5 |
| | | 3 | 3 | 23.48 | 23.49 | 23.66 | |
| | | 6 | 0 | 23.83 | 23.77 | 23.99 | 24.5 |



| Band/BW | Modulation | RB Size | RB Offset | Low CH 26065 | Mid CH 26365 | High CH 26665 | Tune Up |
|---------|------------|---------|-----------|-------------------------|-------------------------|-------------------------|---------|
| | | | | Frequency 1852.5 MHz | Frequency 1882.5 MHz | Frequency 1912.5 MHz | |
| 25/ 5 | QPSK | 1 | 0 | 23.88 | 23.83 | 24.03 | 24.5 |
| | | 1 | 5 | 23.84 | 23.75 | 23.99 | |
| | | 3 | 0 | 23.85 | 23.79 | 24.04 | 24.5 |
| | | 3 | 3 | 23.80 | 23.76 | 23.94 | |
| | | 6 | 0 | 23.84 | 23.88 | 24.02 | 24.5 |
| | 16QAM | 1 | 0 | 23.23 | 23.22 | 23.43 | 24.5 |
| | | 1 | 5 | 23.20 | 23.23 | 23.38 | |
| | | 3 | 0 | 23.59 | 23.50 | 23.74 | 24.5 |
| | | 3 | 3 | 23.48 | 23.47 | 23.63 | |
| | | 6 | 0 | 23.80 | 23.81 | 23.95 | 24.5 |

| Band/BW | Modulation | RB Size | RB Offset | Low CH 26090 | Mid CH 26365 | High CH 26640 | Tune Up |
|---------|------------|---------|-----------|-----------------------|-------------------------|-----------------------|---------|
| | | | | Frequency 1855 MHz | Frequency 1882.5 MHz | Frequency 1910 MHz | |
| 25/ 10 | QPSK | 1 | 0 | 23.85 | 23.86 | 24.03 | 24.5 |
| | | 1 | 5 | 23.84 | 23.75 | 24.00 | |
| | | 3 | 0 | 23.82 | 23.83 | 24.00 | 24.5 |
| | | 3 | 3 | 23.81 | 23.75 | 23.97 | |
| | | 6 | 0 | 23.90 | 23.82 | 24.02 | 24.5 |
| | 16QAM | 1 | 0 | 23.23 | 23.19 | 23.39 | 24.5 |
| | | 1 | 5 | 23.25 | 23.19 | 23.41 | |
| | | 3 | 0 | 23.59 | 23.51 | 23.71 | 24.5 |
| | | 3 | 3 | 23.50 | 23.45 | 23.69 | |
| | | 6 | 0 | 23.84 | 23.75 | 24.00 | 24.5 |



| Band/BW | Modulation | RB Size | RB Offset | Low CH 26115 | Mid CH 26365 | High CH 26615 | Tune Up |
|---------|------------|---------|-----------|-------------------------|-------------------------|-------------------------|---------|
| | | | | Frequency 1857.5 MHz | Frequency 1882.5 MHz | Frequency 1907.5 MHz | |
| 25/ 15 | QPSK | 1 | 0 | 23.92 | 23.86 | 24.00 | 24.5 |
| | | 1 | 5 | 23.82 | 23.80 | 23.95 | |
| | | 3 | 0 | 23.88 | 23.86 | 24.01 | 24.5 |
| | | 3 | 3 | 23.78 | 23.76 | 23.98 | |
| | | 6 | 0 | 23.91 | 23.87 | 24.02 | 24.5 |
| | 16QAM | 1 | 0 | 23.27 | 23.26 | 23.39 | 24.5 |
| | | 1 | 5 | 23.24 | 23.20 | 23.41 | |
| | | 3 | 0 | 23.55 | 23.56 | 23.73 | 24.5 |
| | | 3 | 3 | 23.54 | 23.45 | 23.70 | |
| | | 6 | 0 | 23.78 | 23.79 | 23.96 | 24.5 |

| Band/BW | Modulation | RB Size | RB Offset | Low CH 26140 | Mid CH 26365 | High CH 26590 | Tune Up |
|---------|------------|---------|-----------|-----------------------|-------------------------|-----------------------|---------|
| | | | | Frequency 1860 MHz | Frequency 1882.5 MHz | Frequency 1905 MHz | |
| 25/ 20 | QPSK | 1 | 0 | 23.93 | 23.90 | 24.08 | 24.5 |
| | | 1 | 5 | 23.86 | 23.83 | 24.01 | |
| | | 3 | 0 | 23.90 | 23.87 | 24.05 | 24.5 |
| | | 3 | 3 | 23.84 | 23.81 | 23.99 | |
| | | 6 | 0 | 23.92 | 23.89 | 24.07 | 24.5 |
| | 16QAM | 1 | 0 | 23.30 | 23.27 | 23.45 | 24.5 |
| | | 1 | 5 | 23.28 | 23.25 | 23.43 | |
| | | 3 | 0 | 23.61 | 23.58 | 23.76 | 24.5 |
| | | 3 | 3 | 23.56 | 23.53 | 23.71 | |
| | | 6 | 0 | 23.86 | 23.83 | 24.01 | 24.5 |



EIRP POWER (dBm)

GSM 1900

| Channel | Frequency (MHz) | Conducted Power (dBm) | G _T -L _c (dB) | EIRP (dBm) | EIRP (mW) | Limit (W) |
|---------|-----------------|-----------------------|-------------------------------------|------------|----------------|-----------|
| 512 | 1850.2 | 29.81 | 3.77 | 33.58 | 2280.34 | 2 |
| 661 | 1880.0 | 29.85 | 3.77 | 33.62 | 2301.44 | 2 |
| 810 | 1909.8 | 29.95 | 3.77 | 33.72 | 2355.05 | 2 |

EDGE 1900

| Channel | Frequency (MHz) | Conducted Power (dBm) | G _T -L _c (dB) | EIRP (dBm) | EIRP (mW) | Limit (W) |
|---------|-----------------|-----------------------|-------------------------------------|------------|---------------|-----------|
| 512 | 1850.2 | 25.18 | 3.77 | 28.95 | 785.24 | 2 |
| 661 | 1880.0 | 25.00 | 3.77 | 28.77 | 753.36 | 2 |
| 810 | 1909.8 | 25.26 | 3.77 | 29.03 | 799.83 | 2 |

LTE BAND 2

CHANNEL BANDWIDTH: 1.4MHz QPSK

| Channel | Frequency (MHz) | Conducted Power (dBm) | G _T -L _c (dB) | EIRP (dBm) | EIRP (mW) | Limit (W) |
|---------|-----------------|-----------------------|-------------------------------------|------------|---------------|-----------|
| 18607 | 1850.7 | 23.42 | 3.77 | 27.19 | 523.60 | 2 |
| 18900 | 1880.0 | 23.55 | 3.77 | 27.32 | 539.51 | 2 |
| 19193 | 1908.3 | 23.73 | 3.77 | 27.50 | 562.34 | 2 |

CHANNEL BANDWIDTH: 1.4MHz 16QAM

| Channel | Frequency (MHz) | Conducted Power (dBm) | G _T -L _c (dB) | EIRP (dBm) | EIRP (mW) | Limit (W) |
|---------|-----------------|-----------------------|-------------------------------------|------------|-----------|-----------|
| 18607 | 1850.7 | 22.53 | 3.77 | 26.30 | 426.58 | 2 |
| 18900 | 1880.0 | 22.53 | 3.77 | 26.30 | 426.58 | 2 |
| 19193 | 1908.3 | 22.49 | 3.77 | 26.26 | 422.67 | 2 |



CHANNEL BANDWIDTH: 3MHz QPSK

| Channel | Frequency (MHz) | Conducted Power (dBm) | G _T -L _c (dB) | EIRP (dBm) | EIRP (mW) | Limit (W) |
|---------|-----------------|-----------------------|-------------------------------------|------------|-----------|-----------|
| 18615 | 1851.5 | 23.84 | 3.77 | 27.61 | 576.77 | 2 |
| 18900 | 1880.0 | 23.59 | 3.77 | 27.36 | 544.5 | 2 |
| 19185 | 1908.5 | 23.76 | 3.77 | 27.53 | 566.24 | 2 |

CHANNEL BANDWIDTH: 3MHz 16QAM

| Channel | Frequency (MHz) | Conducted Power (dBm) | G _T -L _c (dB) | EIRP (dBm) | EIRP (mW) | Limit (W) |
|---------|-----------------|-----------------------|-------------------------------------|------------|---------------|-----------|
| 18615 | 1851.5 | 23.83 | 3.77 | 27.60 | 575.44 | 2 |
| 18900 | 1880.0 | 23.85 | 3.77 | 27.62 | 578.1 | 2 |
| 19185 | 1908.5 | 23.87 | 3.77 | 27.64 | 580.76 | 2 |

CHANNEL BANDWIDTH: 5MHz QPSK

| Channel | Frequency (MHz) | Conducted Power (dBm) | G _T -L _c (dB) | EIRP (dBm) | EIRP (mW) | Limit (W) |
|---------|-----------------|-----------------------|-------------------------------------|------------|-----------|-----------|
| 18625 | 1852.5 | 23.43 | 3.77 | 27.20 | 524.81 | 2 |
| 18900 | 1880.0 | 23.58 | 3.77 | 27.35 | 543.25 | 2 |
| 19175 | 1907.5 | 23.72 | 3.77 | 27.49 | 561.05 | 2 |

CHANNEL BANDWIDTH: 5MHz 16QAM

| Channel | Frequency (MHz) | Conducted Power (dBm) | G _T -L _c (dB) | EIRP (dBm) | EIRP (mW) | Limit (W) |
|---------|-----------------|-----------------------|-------------------------------------|------------|---------------|-----------|
| 18625 | 1852.5 | 23.80 | 3.77 | 27.57 | 571.48 | 2 |
| 18900 | 1880.0 | 23.81 | 3.77 | 27.58 | 572.8 | 2 |
| 19175 | 1907.5 | 23.84 | 3.77 | 27.61 | 576.77 | 2 |



CHANNEL BANDWIDTH: 10MHz QPSK

| Channel | Frequency (MHz) | Conducted Power (dBm) | G _T -L _c (dB) | EIRP (dBm) | EIRP (mW) | Limit (W) |
|---------|-----------------|-----------------------|-------------------------------------|------------|-----------|-----------|
| 18650 | 1855.0 | 23.51 | 3.77 | 27.28 | 534.56 | 2 |
| 18900 | 1880.0 | 23.60 | 3.77 | 27.37 | 545.76 | 2 |
| 19150 | 1905.0 | 23.75 | 3.77 | 27.52 | 564.94 | 2 |

CHANNEL BANDWIDTH: 10MHz 16QAM

| Channel | Frequency (MHz) | Conducted Power (dBm) | G _T -L _c (dB) | EIRP (dBm) | EIRP (mW) | Limit (W) |
|---------|-----------------|-----------------------|-------------------------------------|------------|---------------|-----------|
| 18650 | 1855.0 | 23.82 | 3.77 | 27.59 | 574.12 | 2 |
| 18900 | 1880.0 | 23.84 | 3.77 | 27.61 | 576.77 | 2 |
| 19150 | 1905.0 | 23.86 | 3.77 | 27.63 | 579.43 | 2 |

CHANNEL BANDWIDTH: 15MHz QPSK

| Channel | Frequency (MHz) | Conducted Power (dBm) | G _T -L _c (dB) | EIRP (dBm) | EIRP (mW) | Limit (W) |
|---------|-----------------|-----------------------|-------------------------------------|------------|-----------|-----------|
| 18675 | 1857.5 | 23.49 | 3.77 | 27.26 | 532.11 | 2 |
| 18900 | 1880.0 | 23.56 | 3.77 | 27.33 | 540.75 | 2 |
| 19125 | 1902.5 | 23.73 | 3.77 | 27.50 | 562.34 | 2 |

CHANNEL BANDWIDTH: 15MHz 16QAM

| Channel | Frequency (MHz) | Conducted Power (dBm) | G _T -L _c (dB) | EIRP (dBm) | EIRP (mW) | Limit (W) |
|---------|-----------------|-----------------------|-------------------------------------|------------|---------------|-----------|
| 18675 | 1857.5 | 23.77 | 3.77 | 27.54 | 567.54 | 2 |
| 18900 | 1880.0 | 23.82 | 3.77 | 27.59 | 574.12 | 2 |
| 19125 | 1902.5 | 23.84 | 3.77 | 27.61 | 576.77 | 2 |



CHANNEL BANDWIDTH: 20MHz QPSK

| Channel | Frequency (MHz) | Conducted Power (dBm) | G _T -L _c (dB) | EIRP (dBm) | EIRP (mW) | Limit (W) |
|---------|-----------------|-----------------------|-------------------------------------|------------|-----------|-----------|
| 18675 | 1857.5 | 23.46 | 3.77 | 27.23 | 528.45 | 2 |
| 18900 | 1880.0 | 23.51 | 3.77 | 27.28 | 534.56 | 2 |
| 19125 | 1902.5 | 23.70 | 3.77 | 27.47 | 558.47 | 2 |

CHANNEL BANDWIDTH: 20MHz 16QAM

| Channel | Frequency (MHz) | Conducted Power (dBm) | G _T -L _c (dB) | EIRP (dBm) | EIRP (mW) | Limit (W) |
|---------|-----------------|-----------------------|-------------------------------------|------------|---------------|-----------|
| 18675 | 1857.5 | 23.75 | 3.77 | 27.52 | 564.94 | 2 |
| 18900 | 1880.0 | 23.78 | 3.77 | 27.55 | 568.85 | 2 |
| 19125 | 1902.5 | 23.79 | 3.77 | 27.56 | 570.16 | 2 |



LTE BAND 25

CHANNEL BANDWIDTH: 1.4MHz QPSK

| Channel | Frequency (MHz) | Conducted Power (dBm) | G _T -L _C (dB) | EIRP (dBm) | EIRP (mW) | Limit (W) |
|---------|-----------------|-----------------------|-------------------------------------|------------|---------------|-----------|
| 26047 | 1850.7 | 23.53 | 3.77 | 27.30 | 537.03 | 2 |
| 26340 | 1880.0 | 24.10 | 3.77 | 27.87 | 612.35 | 2 |
| 26683 | 1914.3 | 23.62 | 3.77 | 27.39 | 548.28 | 2 |

CHANNEL BANDWIDTH: 1.4MHz 16QAM

| Channel | Frequency (MHz) | Conducted Power (dBm) | G _T -L _C (dB) | EIRP (dBm) | EIRP (mW) | Limit (W) |
|---------|-----------------|-----------------------|-------------------------------------|------------|-----------|-----------|
| 26047 | 1850.7 | 24.08 | 3.77 | 27.85 | 609.54 | 2 |
| 26340 | 1880.0 | 23.94 | 3.77 | 27.71 | 590.2 | 2 |
| 26683 | 1914.3 | 23.98 | 3.77 | 27.75 | 595.66 | 2 |

CHANNEL BANDWIDTH: 3MHz QPSK

| Channel | Frequency (MHz) | Conducted Power (dBm) | G _T -L _C (dB) | EIRP (dBm) | EIRP (mW) | Limit (W) |
|---------|-----------------|-----------------------|-------------------------------------|------------|-----------|-----------|
| 26055 | 1851.5 | 23.63 | 3.77 | 27.40 | 549.54 | 2 |
| 26340 | 1880.0 | 23.79 | 3.77 | 27.56 | 570.16 | 2 |
| 26675 | 1913.5 | 24.02 | 3.77 | 27.79 | 601.17 | 2 |

CHANNEL BANDWIDTH: 3MHz 16QAM

| Channel | Frequency (MHz) | Conducted Power (dBm) | G _T -L _C (dB) | EIRP (dBm) | EIRP (mW) | Limit (W) |
|---------|-----------------|-----------------------|-------------------------------------|------------|---------------|-----------|
| 26055 | 1851.5 | 23.88 | 3.77 | 27.65 | 582.1 | 2 |
| 26340 | 1880.0 | 24.00 | 3.77 | 27.77 | 598.41 | 2 |
| 26675 | 1913.5 | 24.12 | 3.77 | 27.89 | 615.18 | 2 |



CHANNEL BANDWIDTH: 5MHz QPSK

| Channel | Frequency (MHz) | Conducted Power (dBm) | G _T -L _c (dB) | EIRP (dBm) | EIRP (mW) | Limit (W) |
|---------|-----------------|-----------------------|-------------------------------------|------------|-----------|-----------|
| 26065 | 1852.5 | 23.77 | 3.77 | 27.54 | 567.54 | 2 |
| 26340 | 1880.0 | 23.69 | 3.77 | 27.46 | 557.19 | 2 |
| 26665 | 1912.5 | 23.76 | 3.77 | 27.53 | 566.24 | 2 |

CHANNEL BANDWIDTH: 5MHz 16QAM

| Channel | Frequency (MHz) | Conducted Power (dBm) | G _T -L _c (dB) | EIRP (dBm) | EIRP (mW) | Limit (W) |
|---------|-----------------|-----------------------|-------------------------------------|------------|---------------|-----------|
| 26065 | 1852.5 | 24.17 | 3.77 | 27.94 | 622.3 | 2 |
| 26340 | 1880.0 | 24.24 | 3.77 | 28.01 | 632.41 | 2 |
| 26665 | 1912.5 | 24.52 | 3.77 | 28.29 | 674.53 | 2 |

CHANNEL BANDWIDTH: 10MHz QPSK

| Channel | Frequency (MHz) | Conducted Power (dBm) | G _T -L _c (dB) | EIRP (dBm) | EIRP (mW) | Limit (W) |
|---------|-----------------|-----------------------|-------------------------------------|------------|-----------|-----------|
| 26090 | 1855.0 | 24.00 | 3.77 | 27.77 | 598.41 | 2 |
| 26340 | 1880.0 | 23.66 | 3.77 | 27.43 | 553.35 | 2 |
| 26640 | 1910.0 | 23.85 | 3.77 | 27.62 | 578.10 | 2 |

CHANNEL BANDWIDTH: 10MHz 16QAM

| Channel | Frequency (MHz) | Conducted Power (dBm) | G _T -L _c (dB) | EIRP (dBm) | EIRP (mW) | Limit (W) |
|---------|-----------------|-----------------------|-------------------------------------|------------|---------------|-----------|
| 26090 | 1855.0 | 24.37 | 3.77 | 28.14 | 651.63 | 2 |
| 26340 | 1880.0 | 24.41 | 3.77 | 28.18 | 657.66 | 2 |
| 26640 | 1910.0 | 24.53 | 3.77 | 28.30 | 676.08 | 2 |



CHANNEL BANDWIDTH: 15MHz QPSK

| Channel | Frequency (MHz) | Conducted Power (dBm) | G _T -L _c (dB) | EIRP (dBm) | EIRP (mW) | Limit (W) |
|---------|-----------------|-----------------------|-------------------------------------|------------|-----------|-----------|
| 26115 | 1857.5 | 23.85 | 3.77 | 27.62 | 578.10 | 2 |
| 26340 | 1880.0 | 23.68 | 3.77 | 27.45 | 555.90 | 2 |
| 26615 | 1907.5 | 23.81 | 3.77 | 27.58 | 572.80 | 2 |

CHANNEL BANDWIDTH: 15MHz 16QAM

| Channel | Frequency (MHz) | Conducted Power (dBm) | G _T -L _c (dB) | EIRP (dBm) | EIRP (mW) | Limit (W) |
|---------|-----------------|-----------------------|-------------------------------------|------------|---------------|-----------|
| 26115 | 1857.5 | 24.09 | 3.77 | 27.86 | 610.94 | 2 |
| 26340 | 1880.0 | 24.41 | 3.77 | 28.18 | 657.66 | 2 |
| 26615 | 1907.5 | 24.50 | 3.77 | 28.27 | 671.43 | 2 |

CHANNEL BANDWIDTH: 20MHz QPSK

| Channel | Frequency (MHz) | Conducted Power (dBm) | G _T -L _c (dB) | EIRP (dBm) | EIRP (mW) | Limit (W) |
|---------|-----------------|-----------------------|-------------------------------------|------------|-----------|-----------|
| 26140 | 1860.0 | 23.81 | 3.77 | 27.58 | 572.8 | 2 |
| 26340 | 1880.0 | 23.78 | 3.77 | 27.55 | 568.85 | 2 |
| 26590 | 1905.0 | 23.99 | 3.77 | 27.76 | 597.04 | 2 |

CHANNEL BANDWIDTH: 20MHz 16QAM

| Channel | Frequency (MHz) | Conducted Power (dBm) | G _T -L _c (dB) | EIRP (dBm) | EIRP (mW) | Limit (W) |
|---------|-----------------|-----------------------|-------------------------------------|------------|---------------|-----------|
| 26140 | 1860.0 | 23.80 | 3.77 | 27.57 | 571.48 | 2 |
| 26340 | 1880.0 | 24.42 | 3.77 | 28.19 | 659.17 | 2 |
| 26590 | 1905.0 | 24.28 | 3.77 | 28.05 | 638.26 | 2 |



3.2 FREQUENCY STABILITY MEASUREMENT

3.2.1 LIMITS OF FREQUENCY STABILITY MEASUREMENT

The frequency stability shall be sufficient to ensure that the fundamental emission stays within the authorized frequency block.

3.2.2 TEST PROCEDURE

- a. Device is placed at the oven room. The oven room could control the temperatures and humidity. Power warm up is at least 15 min and power applied should perform before recording frequency error.
- b. EUT is connected the external power supply to control the DC input power. The test voltage range is from minimum to maximum working voltage. Each step shall be record the frequency error rate.
- c. The temperature range step is 10 degrees in this test items. All temperature levels shall be hold the $\pm 0.5^{\circ}\text{C}$ during the measurement testing. The each temperature step shall be at least 0.5 hours, consider the EUT could be test under the stability condition.

NOTE: The frequency error was recorded frequency error from the communication simulator.

3.2.3 TEST SETUP

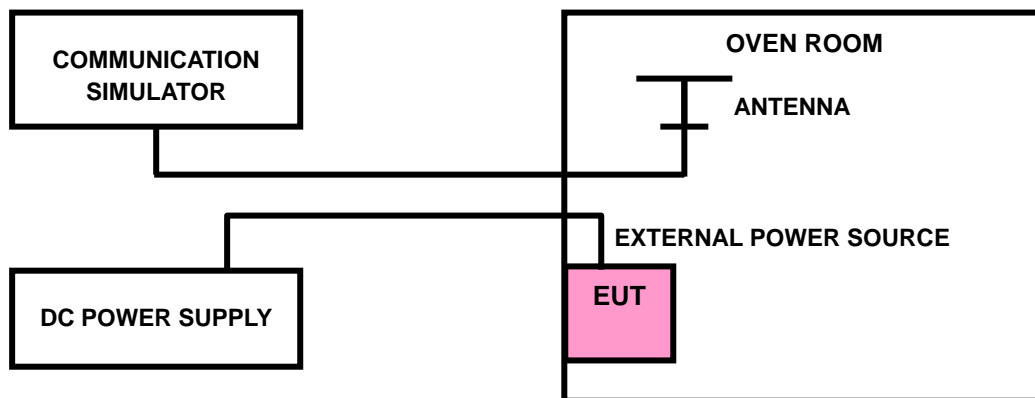



BUREAU VERITAS Test Report No.: RF200520W003-2

3.2.4 TEST RESULTS

The test results was recorded in Report No.: R1811A0536-R2(FCC ID: XMR201707BG96).



3.3 OCCUPIED BANDWIDTH MEASUREMENT

3.3.1 TEST PROCEDURES

The EUT makes a call to the communication simulator. All measurements were done at low, middle and high operational frequency range. The communication simulator station system controlled a EUT to export maximum output power under transmission mode and specific channel frequency. Use OBW measurement function of Spectrum analyzer to measure 99 % occupied bandwidth.

3.3.2 TEST SETUP

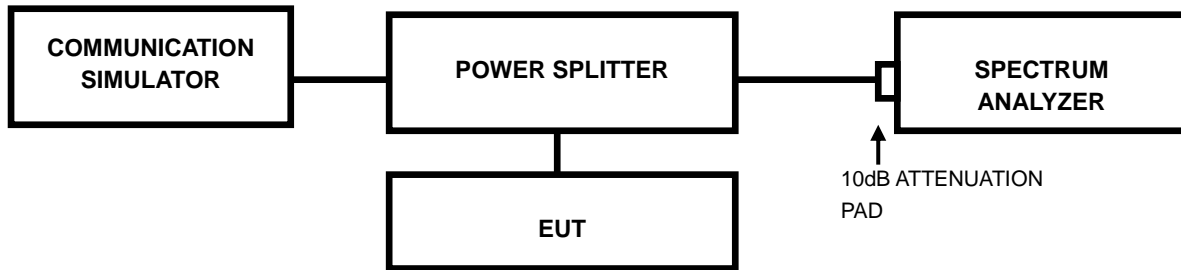

3.3.3 TEST RESULTS

The test results was recorded in Report No.: R1811A0536-R2(FCC ID: XMR201707BG96).



3.4 BAND EDGE MEASUREMENT

3.4.1 LIMITS OF BAND EDGE MEASUREMENT

Power of any emission outside of the authorized operating frequency ranges must be attenuated below the transmitting power (P) by a factor of at least $43 + 10 \log(P)$ dB. In the 1 MHz bands immediately outside and adjacent to the frequency block a resolution bandwidth of at least one percent of the emission bandwidth of the fundamental emission of the transmitter may be employed.

3.4.2 TEST SETUP

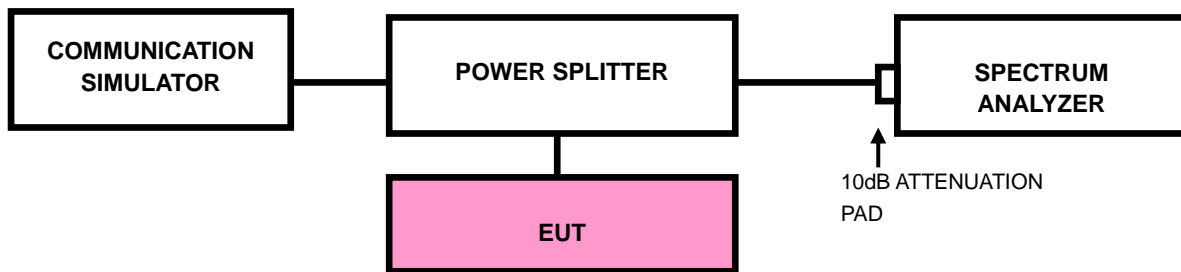



3.4.3 TEST PROCEDURES

- a. All measurements were done at low and high operational frequency range.
- b. The center frequency of spectrum is the band edge frequency and span is 1.5 MHz. RBW of the spectrum is 10kHz and VBW of the spectrum is 30kHz (GSM/GPRS/ EDGE).
- c. The center frequency of spectrum is the band edge frequency and span is 1~5 MHz. RBW of the spectrum is 20kHz and VBW of the spectrum is 100 kHz. (LTE bandwidth 1.4MHz)
- d. The center frequency of spectrum is the band edge frequency and span is 1~5 MHz. RBW of the spectrum is 30kHz and VBW of the spectrum is 100kHz. (LTE bandwidth 3MHz)
- e. The center frequency of spectrum is the band edge frequency and span is 1~5 MHz. RBW of the spectrum is 50kHz and VBW of the spectrum is 200kHz. (LTE bandwidth 5MHz)
- f. The center frequency of spectrum is the band edge frequency and span is 1~5 MHz. RBW of the spectrum is 100kHz and VBW of the spectrum is 300kHz. (LTE bandwidth 10MHz)
- g. The center frequency of spectrum is the band edge frequency and span is 1~5 MHz. RBW of the spectrum is 200kHz and VBW of the spectrum is 1MHz. (LTE bandwidth 15MHz)
- h. The center frequency of spectrum is the band edge frequency and span is 1~5 MHz. RBW of the spectrum is 200kHz and VBW of the spectrum is 1MHz. (LTE bandwidth 20MHz)
- i. Record the max trace plot into the test report.

3.4.4. TEST RESULTS

The test results was recorded in Report No.: R1811A0536-R2(FCC ID: XMR201707BG96).



3.5 CONDUCTED SPURIOUS EMISSIONS

3.5.1 LIMITS OF CONDUCTED SPURIOUS EMISSIONS MEASUREMENT

The power of any emission outside of the authorized operating frequency ranges must be attenuated below the transmitting power (P) by a factor of at least $43 + 10 \log(P)$ dB. The emission limit equal to -13dBm .

3.5.2 TEST PROCEDURE

- a. The EUT makes a phone call to the communication simulator. All measurements were done at low, middle and high operational frequency range.
- b. Measuring frequency range is from 30 MHz to 19.1GHz. 10dB attenuation pad is connected with spectrum. RBW=1MHz and VBW=3MHz is used for conducted emission measurement.

3.5.3 TEST SETUP

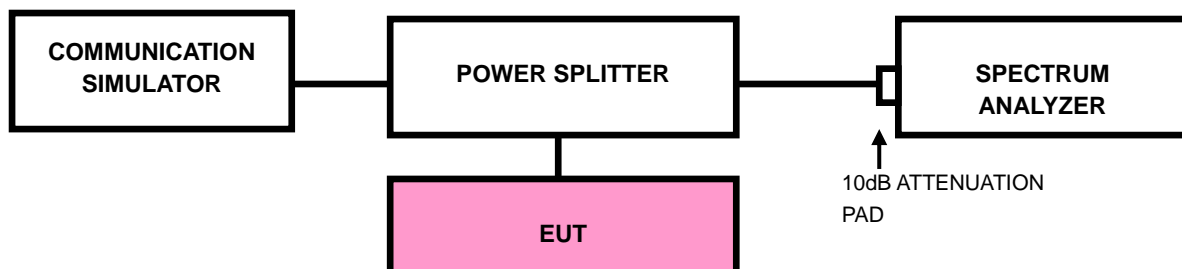

3.5.4 TEST RESULTS

The test results was recorded in Report No.: R1811A0536-R2(FCC ID: XMR201707BG96).



3.6 RADIATED EMISSION MEASUREMENT

3.6.1 LIMITS OF RADIATED EMISSION MEASUREMENT

The power of any emission outside of the authorized operating frequency ranges must be attenuated below the transmitting power (P) by a factor of at least $43 + 10 \log(P)$ dB. The emission limit equal to -13dBm .

3.6.2 TEST PROCEDURES

- a. Substitution method is used for E.I.R.P measurement. In the semi-anechoic chamber, EUT placed on the 0.8m height of Turn Table, rotated the table around 360 degrees to search the maximum radiation power and receiver antenna shall be rotated vertical and horizontal polarization and moved height from 1m to 4m to find the maximum polar radiated power. The “Read Value” is the spectrum reading the maximum power value.
- b. The substitution horn antenna is substituted for EUT at the same position and signals generator export the CW signal to the substitution antenna via a TX cable. Rotated the Turn Table and moved receiving antenna to find the maximum radiation power. Adjust output power level of S.G to get a Value of spectrum reading equal to “Read Value “ of step a. Record the power level of S.G
- c. $\text{EIRP} = \text{Output power level of S.G} - \text{TX cable loss} + \text{Antenna gain of substitution horn}$.

NOTE: The resolution bandwidth and video bandwidth of test receiver/spectrum analyzer is 1MHz/3MHz.

3.6.3 DEVIATION FROM TEST STANDARD

No deviation

3.6.4 TEST SETUP

< Frequency Range 30MHz~1GHz >

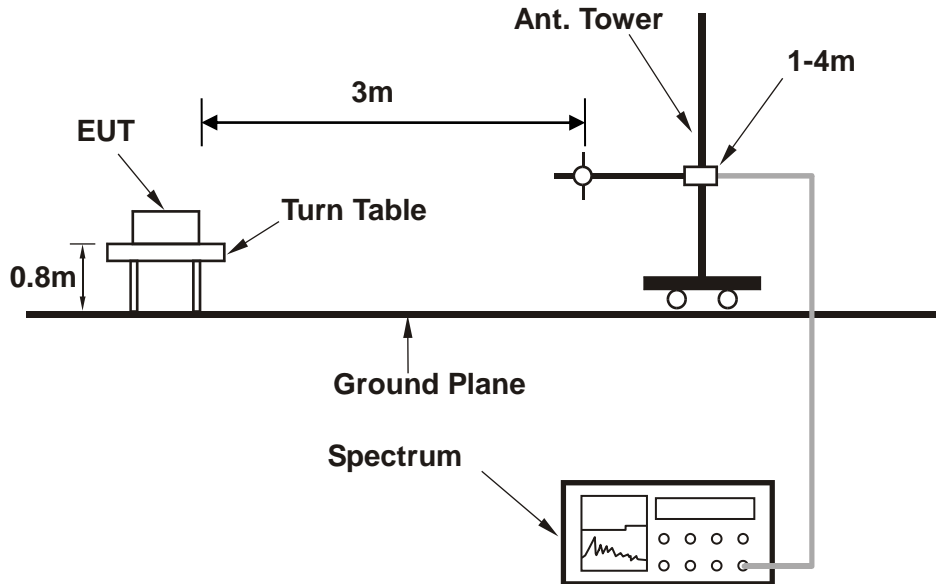

<Frequency Range above 1GHz>

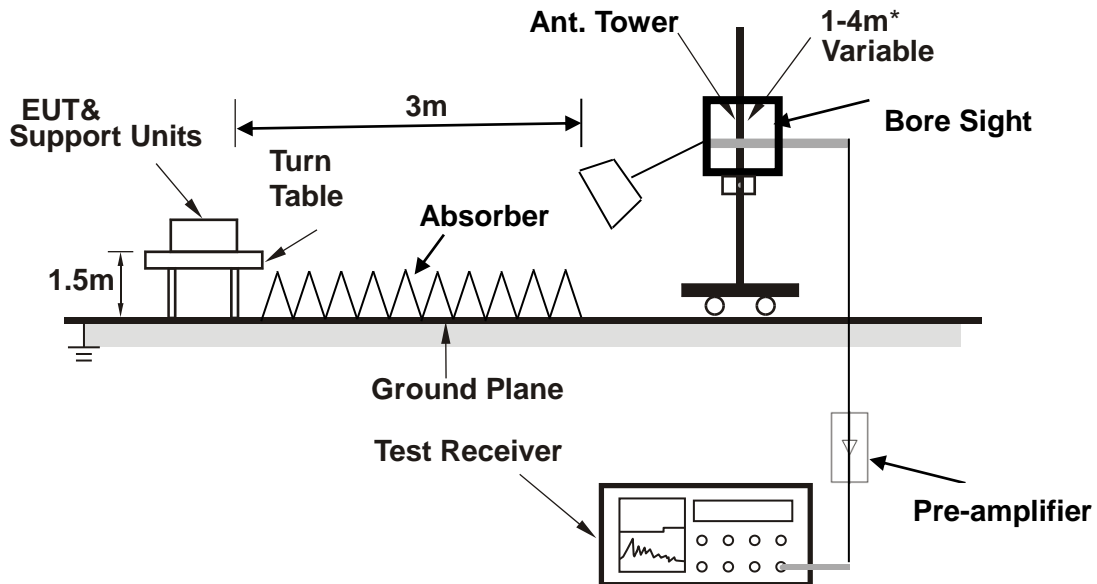

Note: Above 1G is a directional antenna

Depends on the EUT height and the antenna 3dB beamwidth both, refer to section 7.3 of CISPR 16-2-3.

For the actual test configuration, please refer to the attached file (Test Setup Photo).



3.6.5 TEST RESULTS

BELOW 1GHz WORST-CASE DATA FROM ANT 0

30 MHz – 1GHz data:

LTE Band 25

CHANNEL BANDWIDTH: 3Hz / QPSK

| | | | |
|--|------------------|------------------------|---------------|
| MODE | TX channel 26365 | FREQUENCY RANGE | Below 1000MHz |
| ENVIRONMENTAL CONDITIONS | 23deg. C, 70%RH | INPUT POWER | DC 5V |
| TESTED BY | Tony | | |
| ANTENNA POLARITY & TEST DISTANCE: HORIZONTAL AT 3 M | | | |

| | Freq | Level | Read Level | Limit Line | Over Limit | Factor | Remark | Pol/Phase |
|---|------|---------|------------|------------|------------|--------|-------------|------------|
| | MHz | dBm/m | dBm | dBm/m | dB | dB/m | | |
| 1 | PP | 31.940 | -37.91 | -55.38 | -13.00 | -24.91 | 17.47 Peak | Horizontal |
| 2 | | 86.260 | -46.83 | -39.56 | -13.00 | -33.83 | -7.27 Peak | Horizontal |
| 3 | | 175.500 | -57.94 | -41.71 | -13.00 | -44.94 | -16.23 Peak | Horizontal |
| 4 | | 274.440 | -61.95 | -49.00 | -13.00 | -48.95 | -12.95 Peak | Horizontal |
| 5 | | 310.330 | -58.70 | -47.49 | -13.00 | -45.70 | -11.21 Peak | Horizontal |
| 6 | | 422.850 | -69.85 | -62.11 | -13.00 | -56.85 | -7.74 Peak | Horizontal |

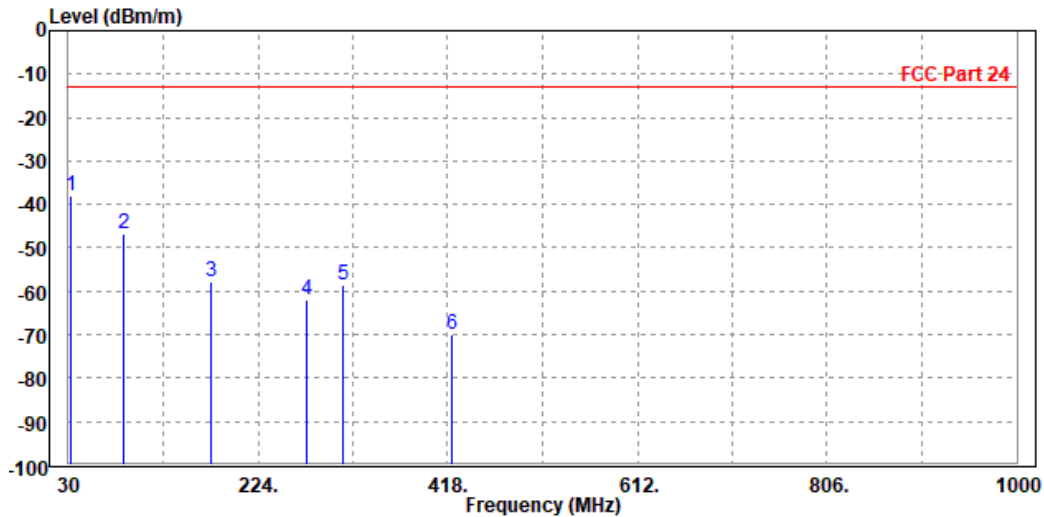



**BUREAU
VERITAS**

Test Report No.: RF200520W003-2

| | | | |
|--|------------------|------------------------|---------------|
| MODE | TX channel 26365 | FREQUENCY RANGE | Below 1000MHz |
| ENVIRONMENTAL CONDITIONS | 23deg. C, 70%RH | INPUT POWER | DC 5V |
| TESTED BY | Tony | | |
| ANTENNA POLARITY & TEST DISTANCE: VERTICAL AT 3 M | | | |

| | Freq | Level | Read Level | Limit Line | Over Limit | Factor | Remark | Pol/Phase |
|---|------|---------|------------|------------|------------|--------|-------------|-----------|
| | MHz | dBm/m | dBm | dBm/m | dB | dB/m | | |
| 1 | PP | 30.970 | -43.19 | -48.02 | -13.00 | -30.19 | 4.83 Peak | Vertical |
| 2 | | 46.490 | -43.70 | -41.09 | -13.00 | -30.70 | -2.61 Peak | Vertical |
| 3 | | 67.830 | -46.50 | -32.79 | -13.00 | -33.50 | -13.71 Peak | Vertical |
| 4 | | 85.290 | -50.19 | -41.03 | -13.00 | -37.19 | -9.16 Peak | Vertical |
| 5 | | 171.620 | -57.26 | -44.89 | -13.00 | -44.26 | -12.37 Peak | Vertical |
| 6 | | 278.320 | -56.73 | -47.48 | -13.00 | -43.73 | -9.25 Peak | Vertical |

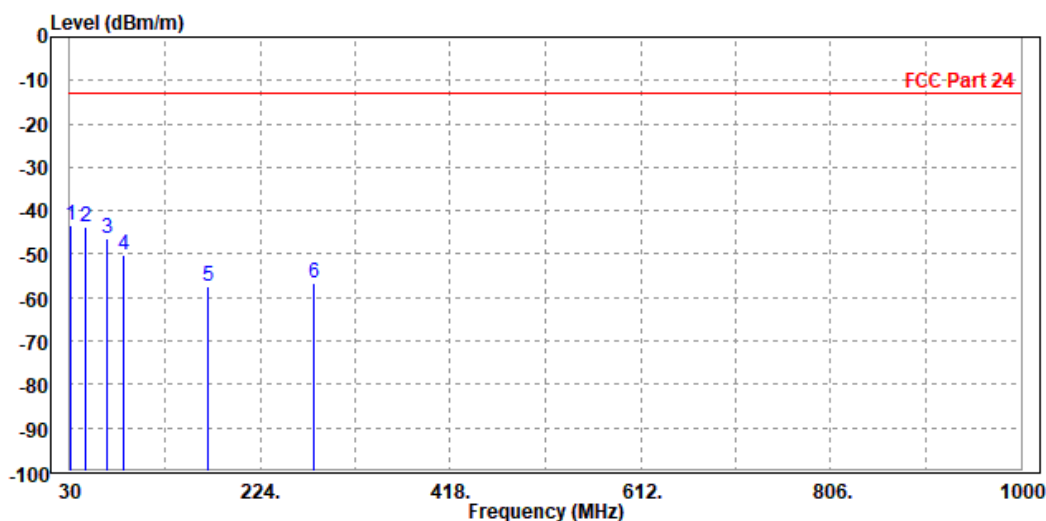



ABOVE 1GHz DATA

Note: For higher frequency, the emission is too low to be detected.

WORST-CASE DATA

PCS 1900:

CH 512

| | | | |
|--|-----------------|------------------------|---------------|
| MODE | TX channel 512 | FREQUENCY RANGE | Above 1000MHz |
| ENVIRONMENTAL CONDITIONS | 23deg. C, 70%RH | INPUT POWER | DC 5V |
| TESTED BY | Tony | | |
| ANTENNA POLARITY & TEST DISTANCE: HORIZONTAL AT 3 M | | | |

| | Freq | Level | Read Level | Limit Line | Over Limit | Factor | Remark | Pol/Phase |
|------|----------|--------|------------|------------|------------|--------|--------|------------|
| | MHz | dBm/m | dBm | dBm/m | dB | dB/m | | |
| 1 | 3700.000 | -49.81 | -58.60 | -13.00 | -36.81 | 8.79 | Peak | Horizontal |
| 2 PP | 5550.600 | -49.12 | -59.31 | -13.00 | -36.12 | 10.19 | Peak | Horizontal |

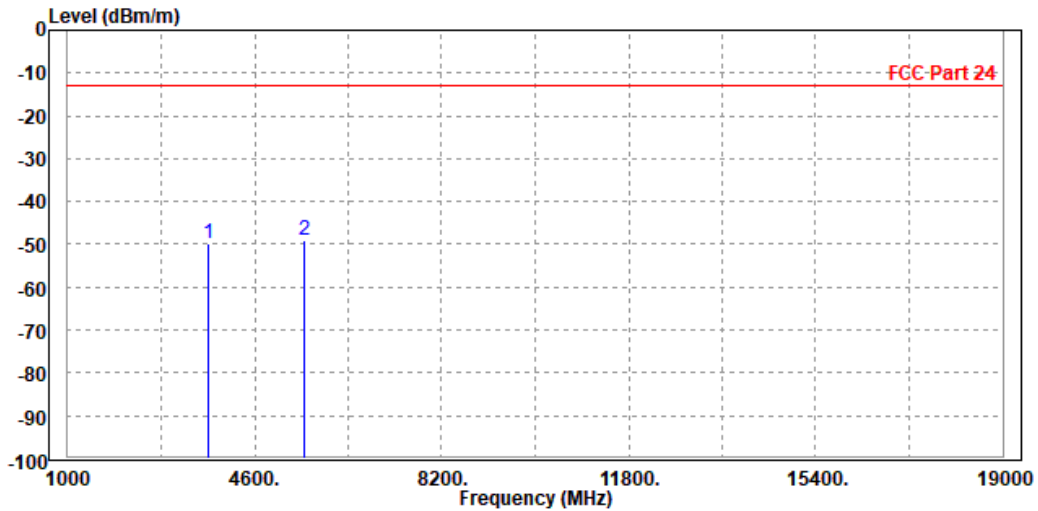



BUREAU VERITAS

Test Report No.: RF200520W003-2

| | | | |
|--|-----------------|-----------------|---------------|
| MODE | TX channel 512 | FREQUENCY RANGE | Above 1000MHz |
| ENVIRONMENTAL CONDITIONS | 23deg. C, 70%RH | INPUT POWER | DC 5V |
| TESTED BY | Tony | | |
| ANTENNA POLARITY & TEST DISTANCE: VERTICAL AT 3 M | | | |

| | Read | Limit | Over | | | | |
|---------------|--------|--------|--------|--------|--------|--------|-----------|
| Freq | Level | Level | Line | Limit | Factor | Remark | Pol/Phase |
| MHz | dBm/m | dBm | dBm/m | dB | dB/m | | |
| 1 PP 3700.000 | -48.40 | -57.65 | -13.00 | -35.40 | 9.25 | Peak | Vertical |
| 2 5550.600 | -49.41 | -59.31 | -13.00 | -36.41 | 9.90 | Peak | Vertical |

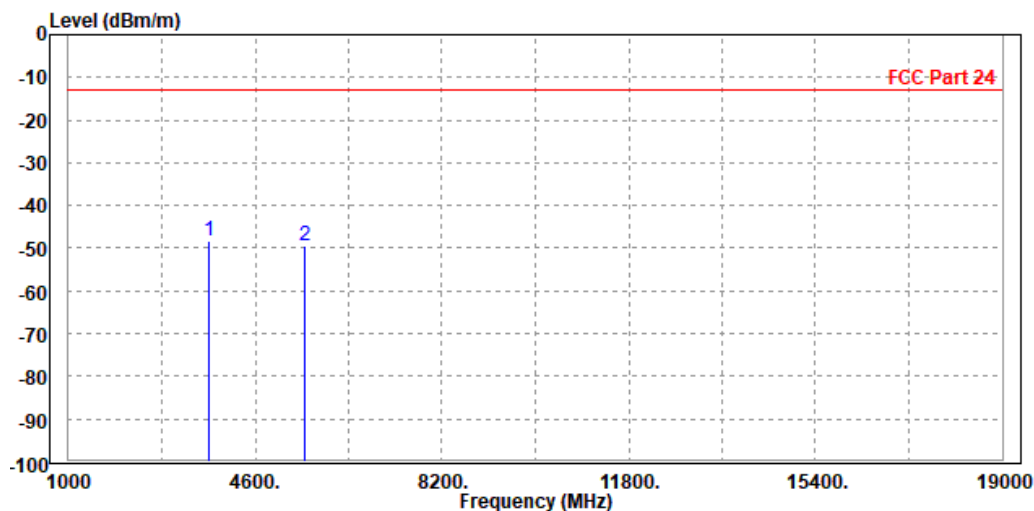



CH 661

| | | | |
|--|-----------------|-----------------|---------------|
| MODE | TX channel 661 | FREQUENCY RANGE | Above 1000MHz |
| ENVIRONMENTAL CONDITIONS | 23deg. C, 70%RH | INPUT POWER | DC 5V |
| TESTED BY | Tony | | |
| ANTENNA POLARITY & TEST DISTANCE: HORIZONTAL AT 3 M | | | |

| | Freq | Level | Read Level | Limit Line | Over Limit | Factor | Remark | Pol/Phase |
|------|----------|--------|------------|------------|------------|--------|--------|------------|
| | MHz | dBm/m | dBm | dBm/m | dB | dB/m | | |
| 1 | 3754.000 | -49.10 | -57.94 | -13.00 | -36.10 | 8.84 | Peak | Horizontal |
| 2 PP | 5640.000 | -48.67 | -59.15 | -13.00 | -35.67 | 10.48 | Peak | Horizontal |

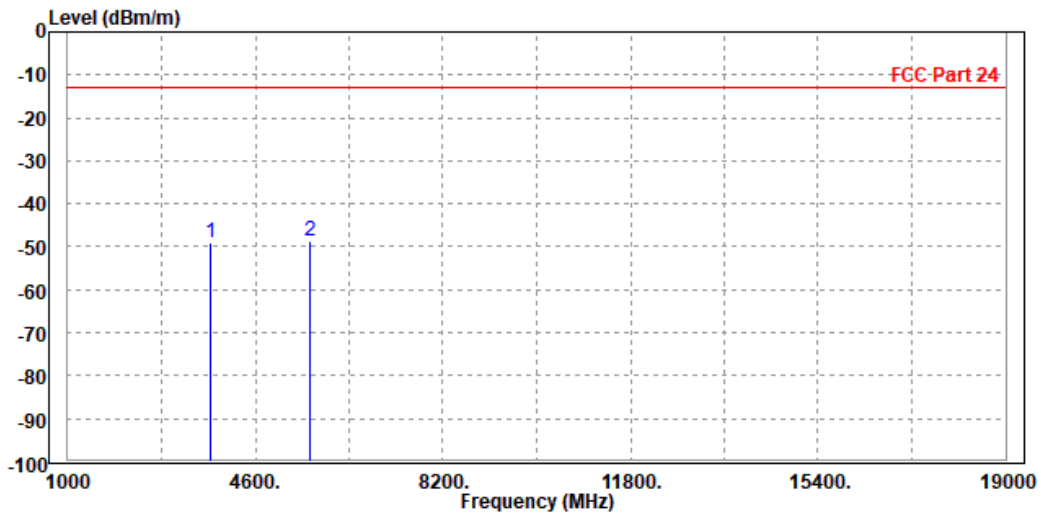



| | | | |
|--|-----------------|-----------------|---------------|
| MODE | TX channel 661 | FREQUENCY RANGE | Above 1000MHz |
| ENVIRONMENTAL CONDITIONS | 23deg. C, 70%RH | INPUT POWER | DC 5V |
| TESTED BY | Tony | | |
| ANTENNA POLARITY & TEST DISTANCE: VERTICAL AT 3 M | | | |

| | Read | Limit | Over | | | | |
|------|-------------|--------|--------|--------|--------|------------|-----------|
| Freq | Level | Level | Line | Limit | Factor | Remark | Pol/Phase |
| MHz | dBm/m | dBm | dBm/m | dB | dB/m | | |
| 1 | 3754.000 | -48.41 | -57.68 | -13.00 | -35.41 | 9.27 Peak | Vertical |
| 2 | PP 5640.000 | -47.77 | -58.02 | -13.00 | -34.77 | 10.25 Peak | Vertical |

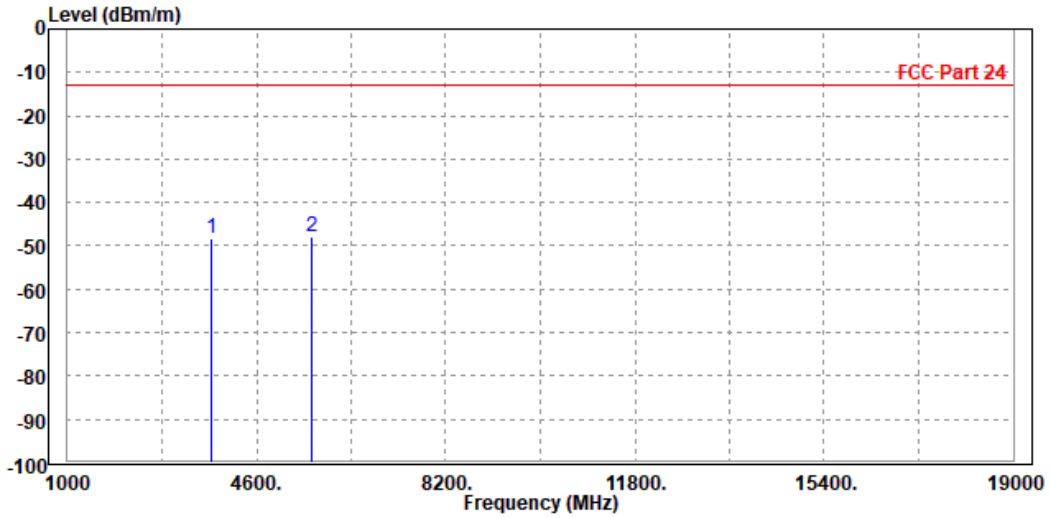



CH 810

| | | | |
|--|-----------------|-----------------|---------------|
| MODE | TX channel 810 | FREQUENCY RANGE | Above 1000MHz |
| ENVIRONMENTAL CONDITIONS | 23deg. C, 70%RH | INPUT POWER | DC 5V |
| TESTED BY | Tony | | |
| ANTENNA POLARITY & TEST DISTANCE: HORIZONTAL AT 3 M | | | |

| | Freq | Level | Read Level | Limit Line | Over Limit | Factor | Remark | Pol/Phase |
|------|----------|--------|------------|------------|------------|--------|--------|------------|
| | MHz | dBm/m | dBm | dBm/m | dB | dB/m | | |
| 1 | 3826.000 | -47.74 | -56.66 | -13.00 | -34.74 | 8.92 | Peak | Horizontal |
| 2 PP | 5729.400 | -47.00 | -57.78 | -13.00 | -34.00 | 10.78 | Peak | Horizontal |

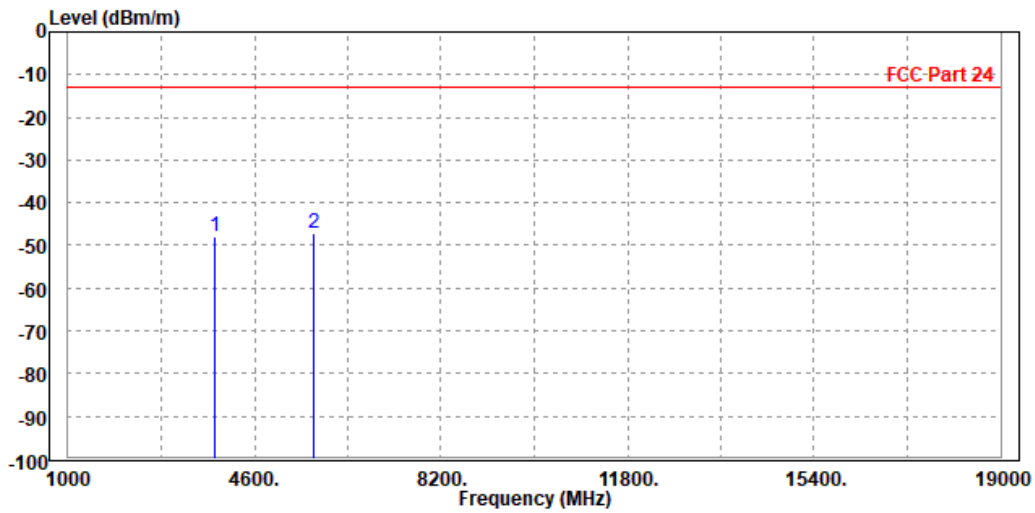



BUREAU VERITAS

Test Report No.: RF200520W003-2

| | | | |
|--|-----------------|-----------------|---------------|
| MODE | TX channel 810 | FREQUENCY RANGE | Above 1000MHz |
| ENVIRONMENTAL CONDITIONS | 23deg. C, 70%RH | INPUT POWER | DC 5V |
| TESTED BY | Tony | | |
| ANTENNA POLARITY & TEST DISTANCE: VERTICAL AT 3 M | | | |

| | Freq | Level | Read Level | Limit Line | Over Limit | Factor | Remark | Pol/Phase |
|------|----------|--------|------------|------------|------------|--------|--------|-----------|
| | MHz | dBm/m | dBm | dBm/m | dB | dB/m | | |
| 1 | 3826.000 | -47.71 | -57.00 | -13.00 | -34.71 | 9.29 | Peak | Vertical |
| 2 PP | 5729.400 | -46.59 | -57.18 | -13.00 | -33.59 | 10.59 | Peak | Vertical |

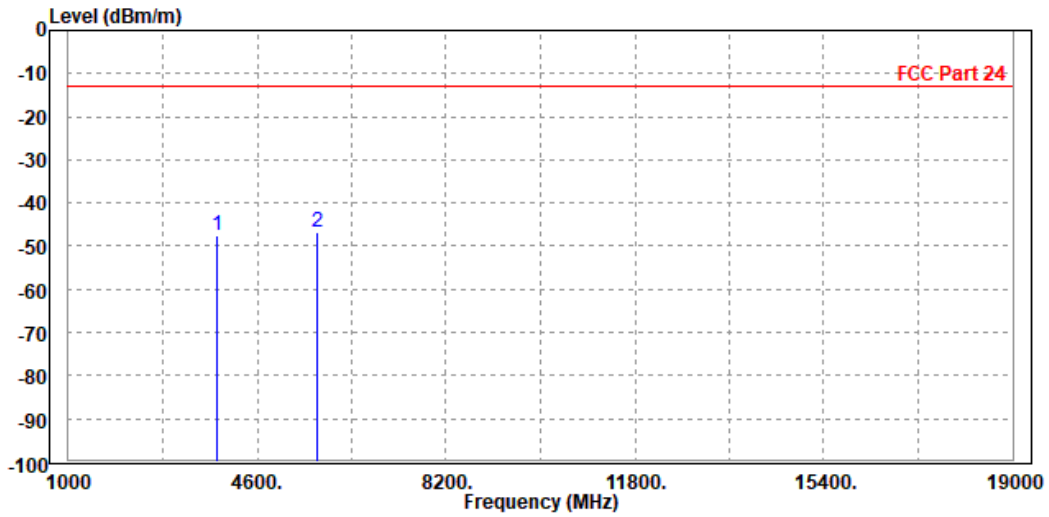



EDGE 1900:

CH 512

| | | | |
|--|-----------------|-----------------|--------------------|
| MODE | TX channel 512 | FREQUENCY RANGE | Above 1000MHz |
| ENVIRONMENTAL CONDITIONS | 23deg. C, 70%RH | INPUT POWER | DC 5V from adapter |
| TESTED BY | Tony Xiong | | |
| ANTENNA POLARITY & TEST DISTANCE: HORIZONTAL AT 3 M | | | |

| | Freq | Level | Read Level | Limit Line | Over Limit | Factor | Remark | Pol/Phase |
|------|----------|--------|------------|------------|------------|--------|--------|------------|
| | MHz | dBm/m | dBm | dBm/m | dB | dB/m | | |
| 1 | 3700.000 | -48.36 | -57.15 | -13.00 | -35.36 | 8.79 | Peak | Horizontal |
| 2 PP | 5550.600 | -47.97 | -58.16 | -13.00 | -34.97 | 10.19 | Peak | Horizontal |

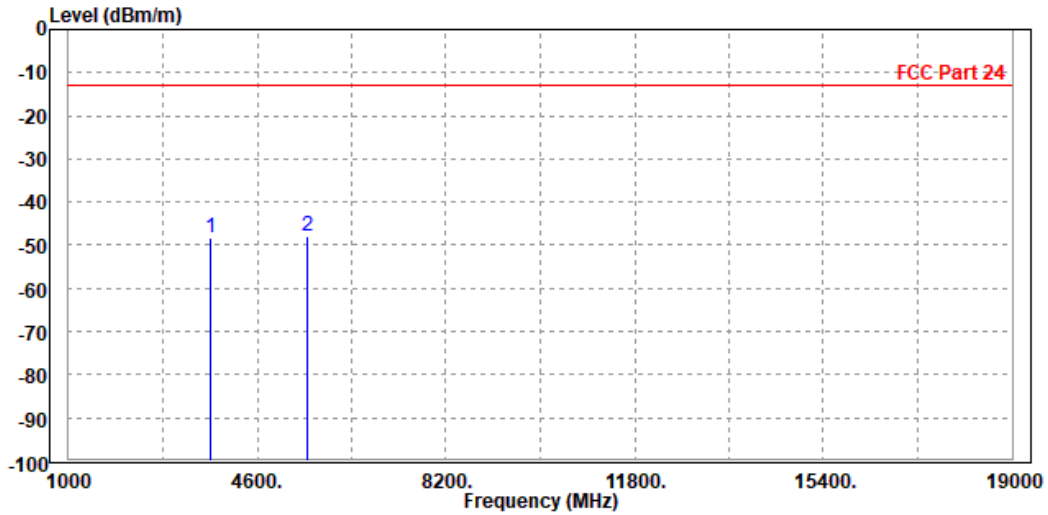



BUREAU VERITAS

Test Report No.: RF200520W003-2

| | | | |
|--|-----------------|-----------------|--------------------|
| MODE | TX channel 512 | FREQUENCY RANGE | Above 1000MHz |
| ENVIRONMENTAL CONDITIONS | 23deg. C, 70%RH | INPUT POWER | DC 5V from adapter |
| TESTED BY | Tony Xiong | | |
| ANTENNA POLARITY & TEST DISTANCE: VERTICAL AT 3 M | | | |

| | Freq | Level | Read Level | Limit Line | Over Limit | Factor | Remark | Pol/Phase |
|---|-------------|--------|------------|------------|------------|--------|--------|-----------|
| | MHz | dBm/m | dBm | dBm/m | dB | dB/m | | |
| 1 | PP 3700.000 | -48.89 | -58.14 | -13.00 | -35.89 | 9.25 | Peak | Vertical |
| 2 | 5550.600 | -49.10 | -59.00 | -13.00 | -36.10 | 9.90 | Peak | Vertical |

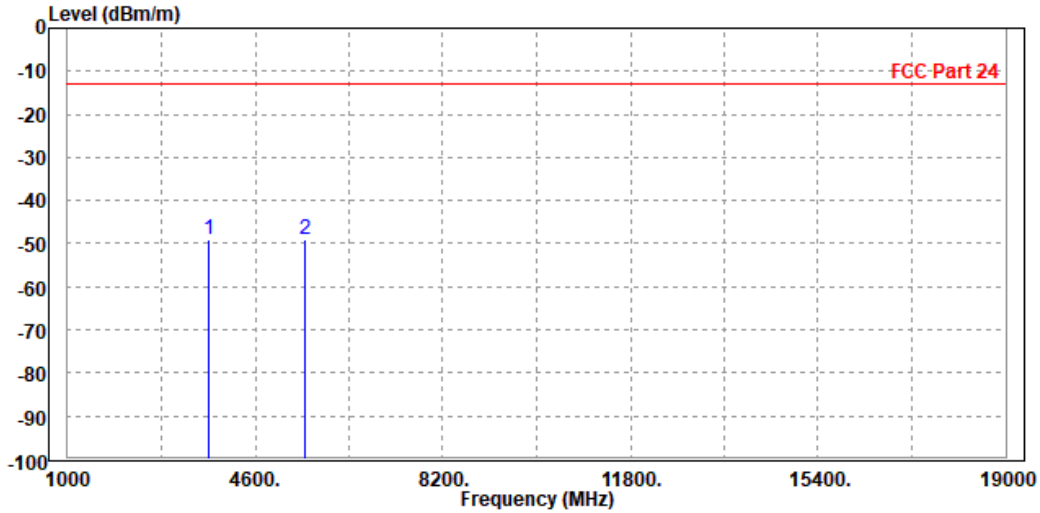



CH 661

| | | | |
|--|-----------------|-----------------|--------------------|
| MODE | TX channel 661 | FREQUENCY RANGE | Above 1000MHz |
| ENVIRONMENTAL CONDITIONS | 23deg. C, 70%RH | INPUT POWER | DC 5V from adapter |
| TESTED BY | Tony Xiong | | |
| ANTENNA POLARITY & TEST DISTANCE: HORIZONTAL AT 3 M | | | |

| | Freq | Level | Read Level | Limit Line | Over Limit | Factor | Remark | Pol/Phase |
|---|-------------|--------|------------|------------|------------|--------|--------|------------|
| | MHz | dBm/m | dBm | dBm/m | dB | dB/m | | |
| 1 | PP 3754.000 | -47.37 | -56.21 | -13.00 | -34.37 | 8.84 | Peak | Horizontal |
| 2 | 5640.000 | -47.64 | -58.12 | -13.00 | -34.64 | 10.48 | Peak | Horizontal |

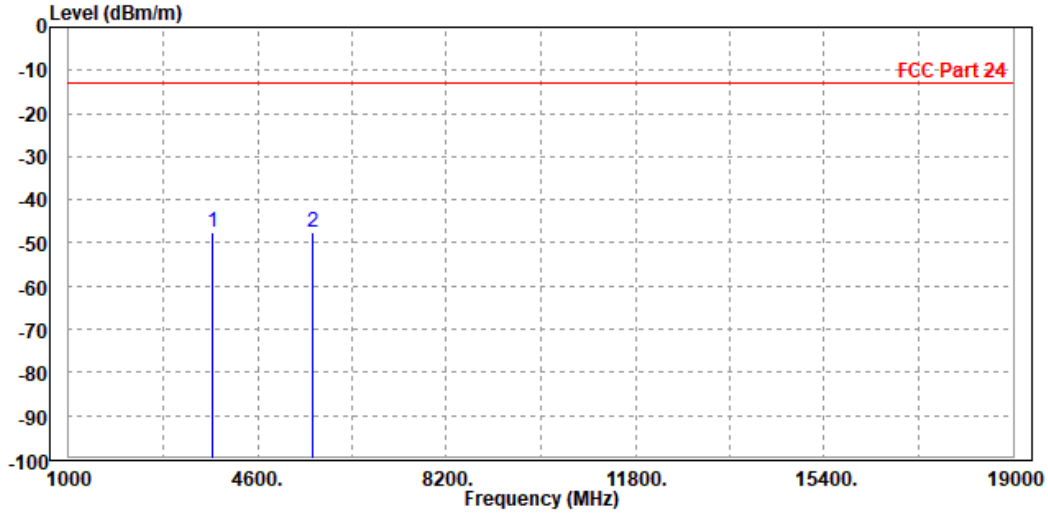



BUREAU VERITAS

Test Report No.: RF200520W003-2

| | | | |
|--|-----------------|-----------------|--------------------|
| MODE | TX channel 661 | FREQUENCY RANGE | Above 1000MHz |
| ENVIRONMENTAL CONDITIONS | 23deg. C, 70%RH | INPUT POWER | DC 5V from adapter |
| TESTED BY | Tony Xiong | | |
| ANTENNA POLARITY & TEST DISTANCE: VERTICAL AT 3 M | | | |

| | Freq | Level | Read Level | Limit Line | Over Limit | Factor | Remark | Pol/Phase |
|---|-------------|--------|------------|------------|------------|--------|--------|-----------|
| | MHz | dBm/m | dBm | dBm/m | dB | dB/m | | |
| 1 | 3754.000 | -48.85 | -58.12 | -13.00 | -35.85 | 9.27 | Peak | Vertical |
| 2 | PP 5640.000 | -46.86 | -57.11 | -13.00 | -33.86 | 10.25 | Peak | Vertical |

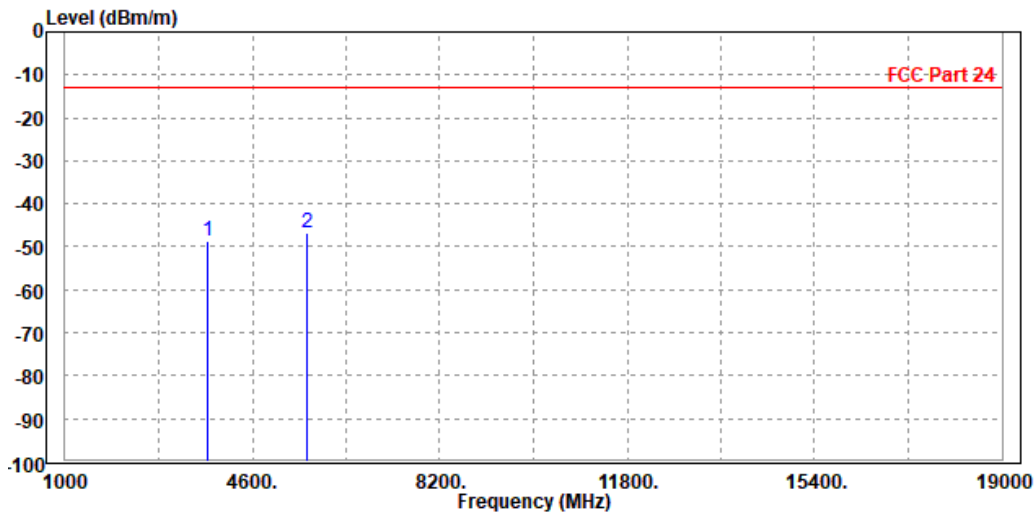



CH 810

| | | | |
|--|-----------------|-----------------|--------------------|
| MODE | TX channel 810 | FREQUENCY RANGE | Above 1000MHz |
| ENVIRONMENTAL CONDITIONS | 23deg. C, 70%RH | INPUT POWER | DC 5V from adapter |
| TESTED BY | Tony Xiong | | |
| ANTENNA POLARITY & TEST DISTANCE: HORIZONTAL AT 3 M | | | |

| | Freq | Level | Read Level | Limit Line | Over Limit | Factor | Remark | Pol/Phase |
|------|----------|--------|------------|------------|------------|--------|--------|------------|
| | MHz | dBm/m | dBm | dBm/m | dB | dB/m | | |
| 1 | 3826.000 | -46.21 | -55.13 | -13.00 | -33.21 | 8.92 | Peak | Horizontal |
| 2 PP | 5729.400 | -45.72 | -56.50 | -13.00 | -32.72 | 10.78 | Peak | Horizontal |

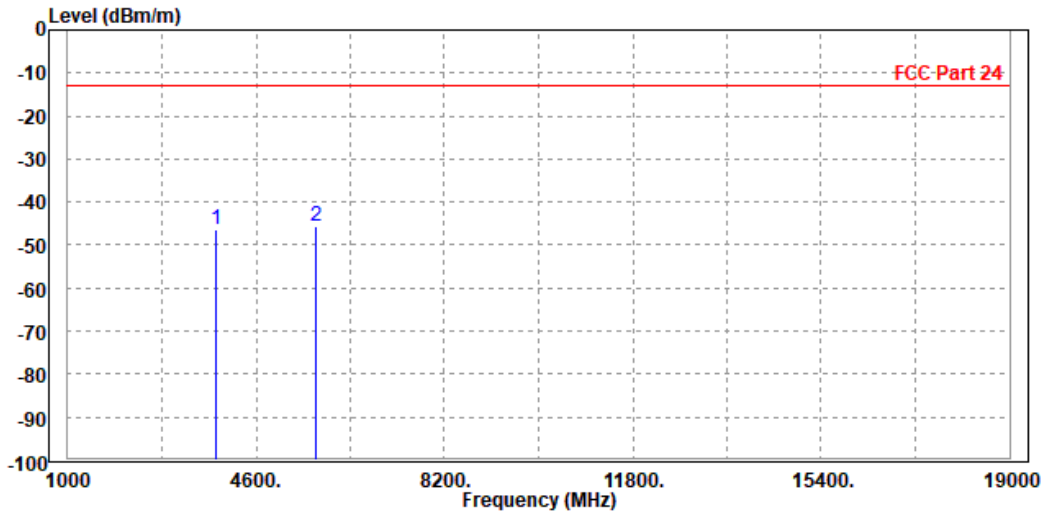



**BUREAU
VERITAS**

Test Report No.: RF200520W003-2

| | | | |
|--|-----------------|------------------------|--------------------|
| MODE | TX channel 810 | FREQUENCY RANGE | Above 1000MHz |
| ENVIRONMENTAL CONDITIONS | 23deg. C, 70%RH | INPUT POWER | DC 5V from adapter |
| TESTED BY | Tony Xiong | | |
| ANTENNA POLARITY & TEST DISTANCE: VERTICAL AT 3 M | | | |

| | Freq | Level | Read Level | Limit Line | Over Limit | Factor | Remark | Pol/Phase |
|------|----------|--------|------------|------------|------------|--------|--------|-----------|
| | MHz | dBm/m | dBm | dBm/m | dB | dB/m | | |
| 1 | 3826.000 | -47.31 | -56.60 | -13.00 | -34.31 | 9.29 | Peak | Vertical |
| 2 PP | 5729.400 | -45.93 | -56.52 | -13.00 | -32.93 | 10.59 | Peak | Vertical |

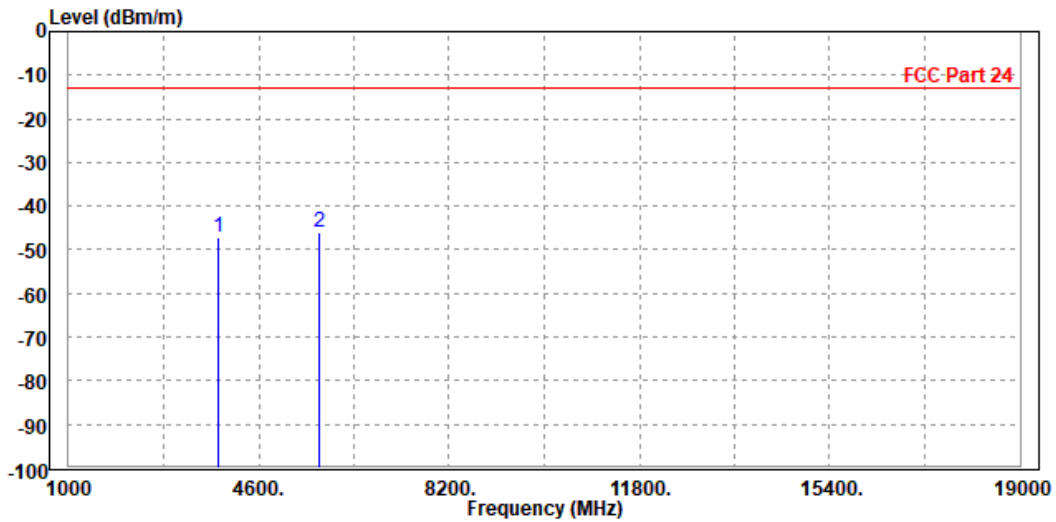



**BUREAU
VERITAS**

Test Report No.: RF200520W003-2

LTE Band 2

CHANNEL BANDWIDTH: 1.4MHz / QPSK

| | | | |
|--|------------------|------------------------|---------------|
| MODE | TX channel 18900 | FREQUENCY RANGE | Above 1000MHz |
| ENVIRONMENTAL CONDITIONS | 23deg. C, 70%RH | INPUT POWER | DC 5V |
| TESTED BY | Tony | | |
| ANTENNA POLARITY & TEST DISTANCE: HORIZONTAL AT 3 M | | | |

| | Freq | Level | Read Level | Limit Line | Over Limit | Factor | Remark | Pol/Phase |
|---|-------------|--------|------------|------------|------------|--------|--------|------------|
| | MHz | dBm/m | dBm | dBm/m | dB | dB/m | | |
| 1 | PP 3754.000 | -46.02 | -54.86 | -13.00 | -33.02 | 8.84 | Peak | Horizontal |
| 2 | 5644.000 | -48.41 | -58.91 | -13.00 | -35.41 | 10.50 | Peak | Horizontal |

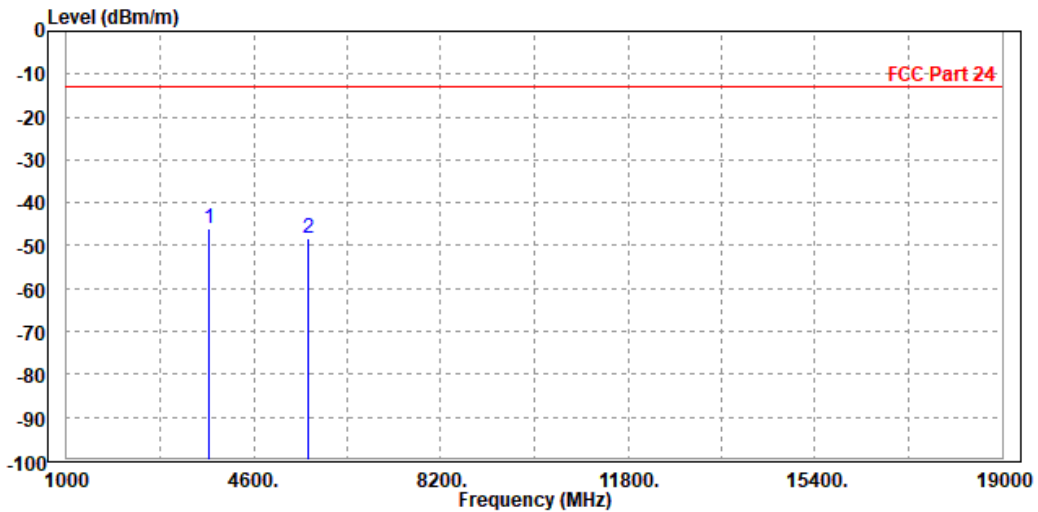



**BUREAU
VERITAS**

Test Report No.: RF200520W003-2

| | | | |
|--|------------------|------------------------|---------------|
| MODE | TX channel 18900 | FREQUENCY RANGE | Above 1000MHz |
| ENVIRONMENTAL CONDITIONS | 23deg. C, 70%RH | INPUT POWER | DC 5V |
| TESTED BY | Tony | | |
| ANTENNA POLARITY & TEST DISTANCE: VERTICAL AT 3 M | | | |

| | Freq | Level | Read Level | Limit Line | Over Limit | Factor | Remark | Pol/Phase |
|---|-------------|--------|------------|------------|------------|--------|--------|-----------|
| | MHz | dBm/m | dBm | dBm/m | dB | dB/m | | |
| 1 | PP 3754.000 | -43.69 | -52.96 | -13.00 | -30.69 | 9.27 | Peak | Vertical |
| 2 | 5640.000 | -48.39 | -58.64 | -13.00 | -35.39 | 10.25 | Peak | Vertical |

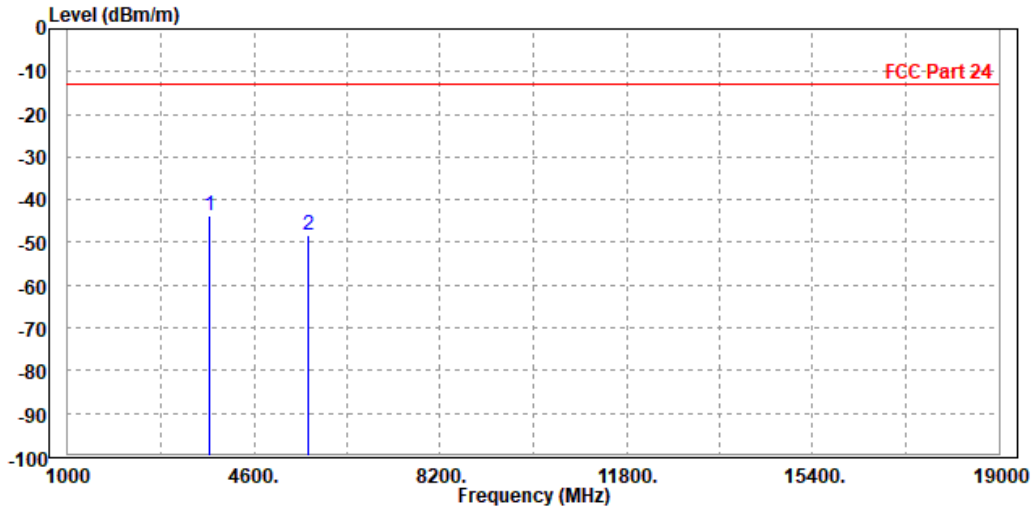



CHANNEL BANDWIDTH: 3MHz / QPSK

| | | | |
|--|------------------|------------------------|---------------|
| MODE | TX channel 18900 | FREQUENCY RANGE | Above 1000MHz |
| ENVIRONMENTAL CONDITIONS | 23deg. C, 70%RH | INPUT POWER | DC 5V |
| TESTED BY | Tony | | |
| ANTENNA POLARITY & TEST DISTANCE: HORIZONTAL AT 3 M | | | |

| | Read | Limit | Over | | | | |
|---------------|--------|--------|--------|--------|--------|--------|------------|
| Freq | Level | Level | Line | Limit | Factor | Remark | Pol/Phase |
| MHz | dBm/m | dBm | dBm/m | dB | dB/m | | |
| 1 PP 3754.000 | -48.62 | -57.46 | -13.00 | -35.62 | 8.84 | Peak | Horizontal |
| 2 5640.000 | -49.00 | -59.48 | -13.00 | -36.00 | 10.48 | Peak | Horizontal |

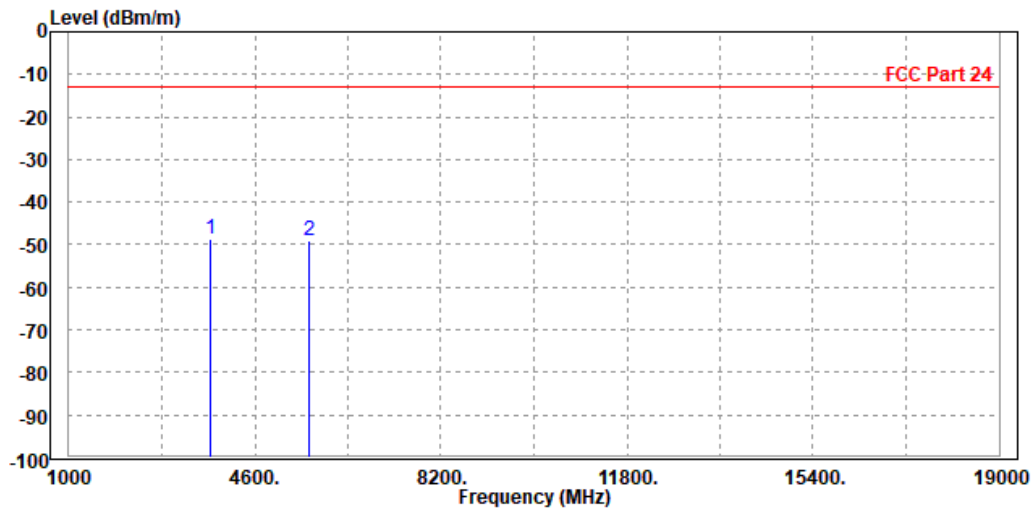



BUREAU VERITAS

Test Report No.: RF200520W003-2

| | | | |
|--|------------------|-----------------|---------------|
| MODE | TX channel 18900 | FREQUENCY RANGE | Above 1000MHz |
| ENVIRONMENTAL CONDITIONS | 23deg. C, 70%RH | INPUT POWER | DC 5V |
| TESTED BY | Tony | | |
| ANTENNA POLARITY & TEST DISTANCE: VERTICAL AT 3 M | | | |

| | Read | Limit | Over | | | | |
|---------------|--------|--------|--------|--------|--------|--------|-----------|
| Freq | Level | Level | Line | Limit | Factor | Remark | Pol/Phase |
| MHz | dBm/m | dBm | dBm/m | dB | dB/m | | |
| 1 PP 3754.000 | -45.25 | -54.52 | -13.00 | -32.25 | 9.27 | Peak | Vertical |
| 2 5640.000 | -48.60 | -58.85 | -13.00 | -35.60 | 10.25 | Peak | Vertical |

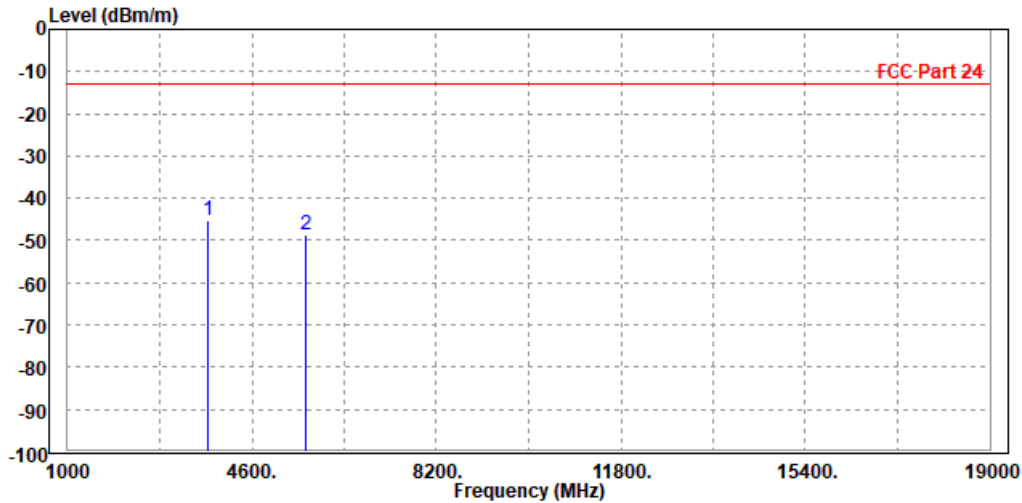



CHANNEL BANDWIDTH: 5MHz / QPSK

| | | | |
|--|------------------|------------------------|---------------|
| MODE | TX channel 18900 | FREQUENCY RANGE | Above 1000MHz |
| ENVIRONMENTAL CONDITIONS | 23deg. C, 70%RH | INPUT POWER | DC 5V |
| TESTED BY | Tony | | |
| ANTENNA POLARITY & TEST DISTANCE: HORIZONTAL AT 3 M | | | |

| | Freq | Level | Read Level | Limit Line | Over Limit | Factor | Remark | Pol/Phase |
|---|-------------|--------|------------|------------|------------|--------|--------|------------|
| | MHz | dBm/m | dBm | dBm/m | dB | dB/m | | |
| 1 | 3754.000 | -48.88 | -57.72 | -13.00 | -35.88 | 8.84 | Peak | Horizontal |
| 2 | PP 5640.000 | -48.47 | -58.95 | -13.00 | -35.47 | 10.48 | Peak | Horizontal |

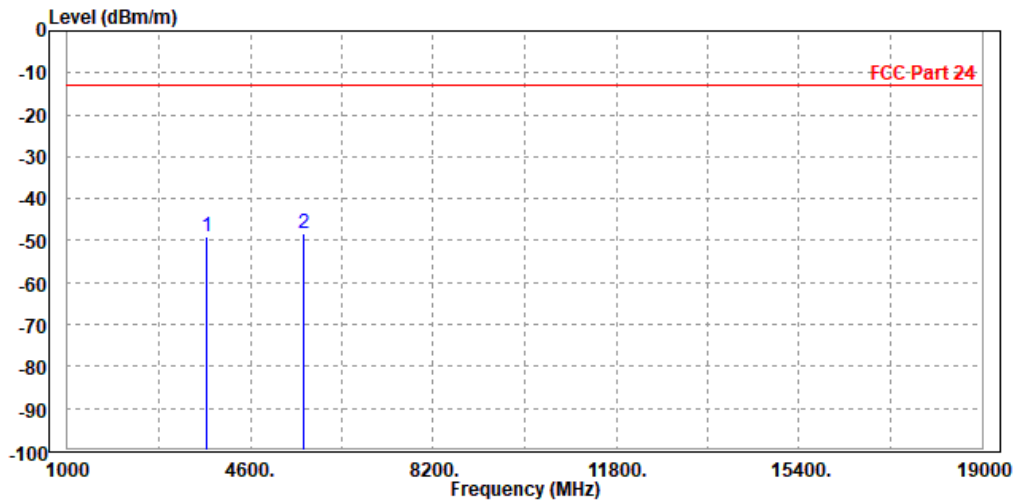



| | | | |
|--|------------------|-----------------|---------------|
| MODE | TX channel 18900 | FREQUENCY RANGE | Above 1000MHz |
| ENVIRONMENTAL CONDITIONS | 23deg. C, 70%RH | INPUT POWER | DC 5V |
| TESTED BY | Tony | | |
| ANTENNA POLARITY & TEST DISTANCE: VERTICAL AT 3 M | | | |

| | Freq | Level | Read Level | Limit Line | Over Limit | Factor | Remark | Pol/Phase |
|---|-------------|--------|------------|------------|------------|--------|--------|-----------|
| | MHz | dBm/m | dBm | dBm/m | dB | dB/m | | |
| 1 | PP 3754.000 | -44.35 | -53.62 | -13.00 | -31.35 | 9.27 | Peak | Vertical |
| 2 | 5640.000 | -47.97 | -58.22 | -13.00 | -34.97 | 10.25 | Peak | Vertical |

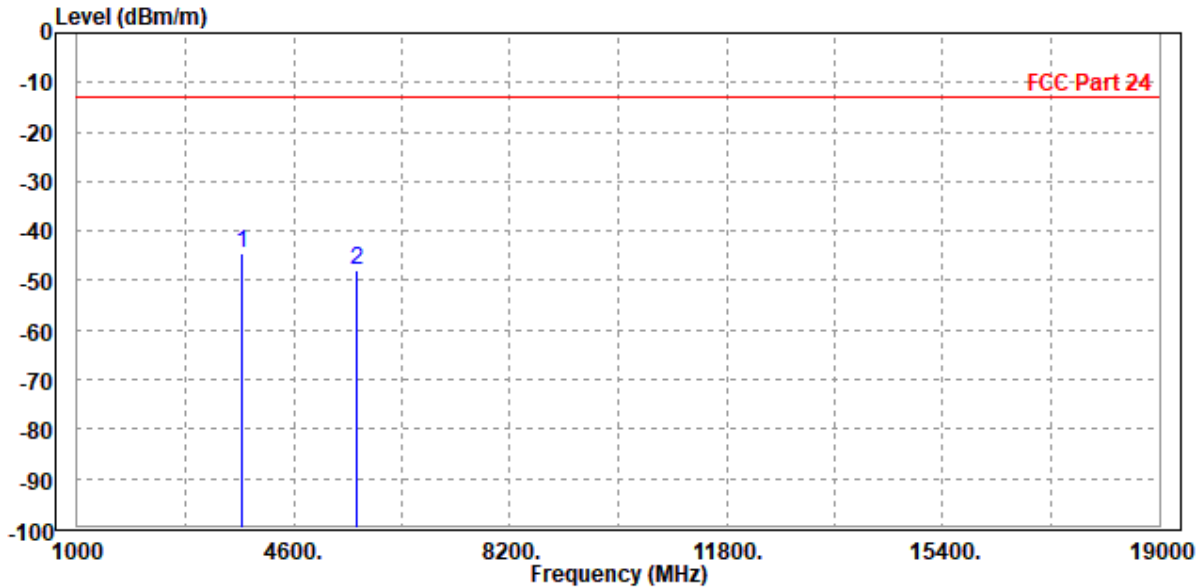



CHANNEL BANDWIDTH: 10MHz / QPSK

| | | | |
|--|------------------|-----------------|---------------|
| MODE | TX channel 18900 | FREQUENCY RANGE | Above 1000MHz |
| ENVIRONMENTAL CONDITIONS | 23deg. C, 70%RH | INPUT POWER | DC 5V |
| TESTED BY | Tony | | |
| ANTENNA POLARITY & TEST DISTANCE: HORIZONTAL AT 3 M | | | |

| | Read | Limit | Over | | | | |
|---------------|--------|--------|--------|--------|--------|--------|------------|
| Freq | Level | Level | Line | Limit | Factor | Remark | Pol/Phase |
| MHz | dBm/m | dBm | dBm/m | dB | dB/m | | |
| 1 PP 3754.000 | -45.85 | -54.69 | -13.00 | -32.85 | 8.84 | Peak | Horizontal |
| 2 5640.000 | -48.65 | -59.13 | -13.00 | -35.65 | 10.48 | Peak | Horizontal |

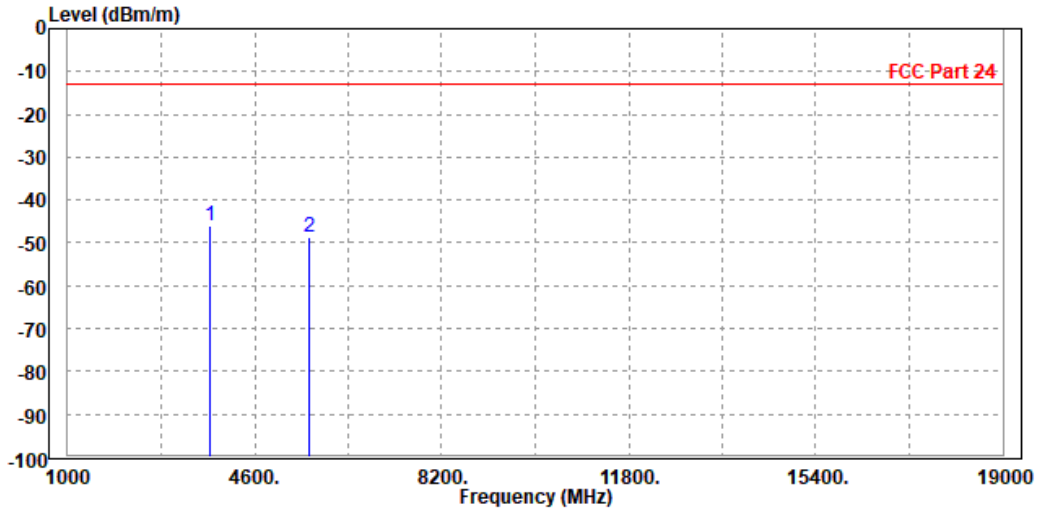



BUREAU VERITAS

Test Report No.: RF200520W003-2

| | | | |
|--|------------------|-----------------|---------------|
| MODE | TX channel 18900 | FREQUENCY RANGE | Above 1000MHz |
| ENVIRONMENTAL CONDITIONS | 23deg. C, 70%RH | INPUT POWER | DC 5V |
| TESTED BY | Tony | | |
| ANTENNA POLARITY & TEST DISTANCE: VERTICAL AT 3 M | | | |

| | Freq | Level | Read Level | Limit Line | Over Limit | Factor | Remark | Pol/Phase |
|---|-------------|--------|------------|------------|------------|--------|--------|-----------|
| | MHz | dBm/m | dBm | dBm/m | dB | dB/m | | |
| 1 | PP 3754.000 | -43.32 | -52.59 | -13.00 | -30.32 | 9.27 | Peak | Vertical |
| 2 | 5640.000 | -47.71 | -57.96 | -13.00 | -34.71 | 10.25 | Peak | Vertical |

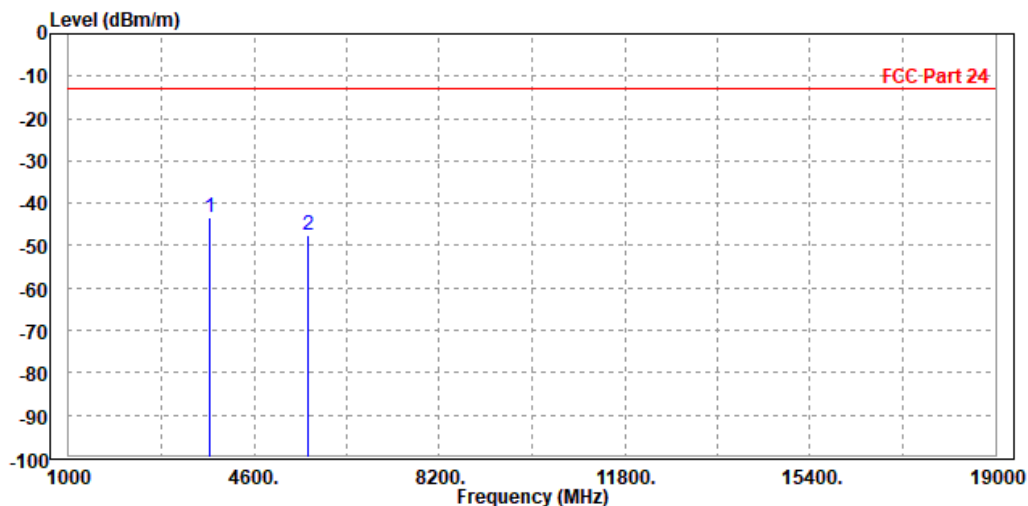



CHANNEL BANDWIDTH: 15MHz / QPSK
CH 18675

| | | | |
|--|------------------|-----------------|---------------|
| MODE | TX channel 18675 | FREQUENCY RANGE | Above 1000MHz |
| ENVIRONMENTAL CONDITIONS | 23deg. C, 70%RH | INPUT POWER | DC 5V |
| TESTED BY | Tony | | |
| ANTENNA POLARITY & TEST DISTANCE: HORIZONTAL AT 3 M | | | |

| | Freq | Level | Read Level | Limit Line | Over Limit | Factor | Remark | Pol/Phase |
|---|-------------|--------|------------|------------|------------|--------|--------|------------|
| | MHz | dBm/m | dBm | dBm/m | dB | dB/m | | |
| 1 | PP 3718.000 | -47.84 | -56.65 | -13.00 | -34.84 | 8.81 | Peak | Horizontal |
| 2 | 5572.500 | -48.77 | -59.03 | -13.00 | -35.77 | 10.26 | Peak | Horizontal |

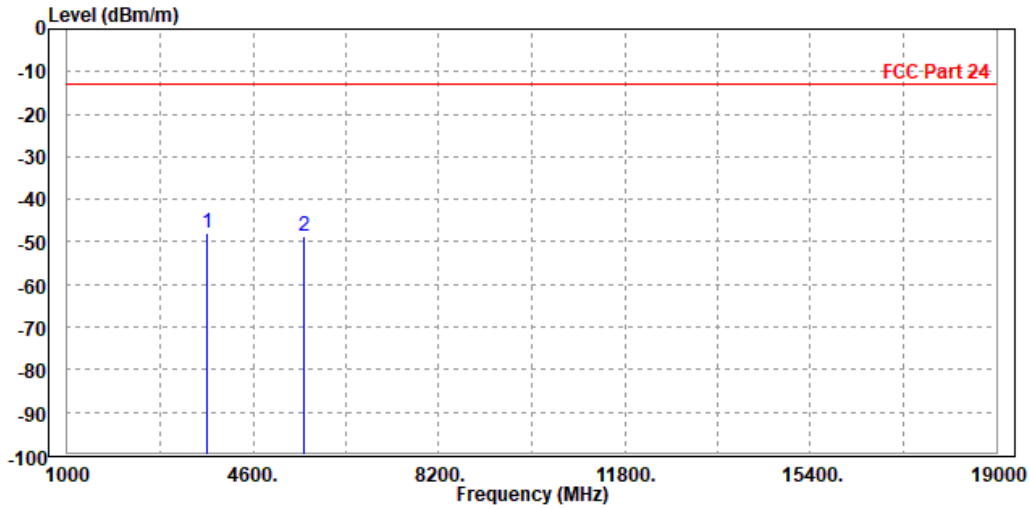



BUREAU VERITAS

Test Report No.: RF200520W003-2

| | | | |
|--|------------------|-----------------|---------------|
| MODE | TX channel 18675 | FREQUENCY RANGE | Above 1000MHz |
| ENVIRONMENTAL CONDITIONS | 23deg. C, 70%RH | INPUT POWER | DC 5V |
| TESTED BY | Tony | | |
| ANTENNA POLARITY & TEST DISTANCE: VERTICAL AT 3 M | | | |

| | Freq | Level | Read Level | Limit Line | Over Limit | Factor | Remark | Pol/Phase |
|---|-------------|--------|------------|------------|------------|--------|--------|-----------|
| | MHz | dBm/m | dBm | dBm/m | dB | dB/m | | |
| 1 | PP 3718.000 | -48.48 | -57.74 | -13.00 | -35.48 | 9.26 | Peak | Vertical |
| 2 | 5572.500 | -48.73 | -58.72 | -13.00 | -35.73 | 9.99 | Peak | Vertical |

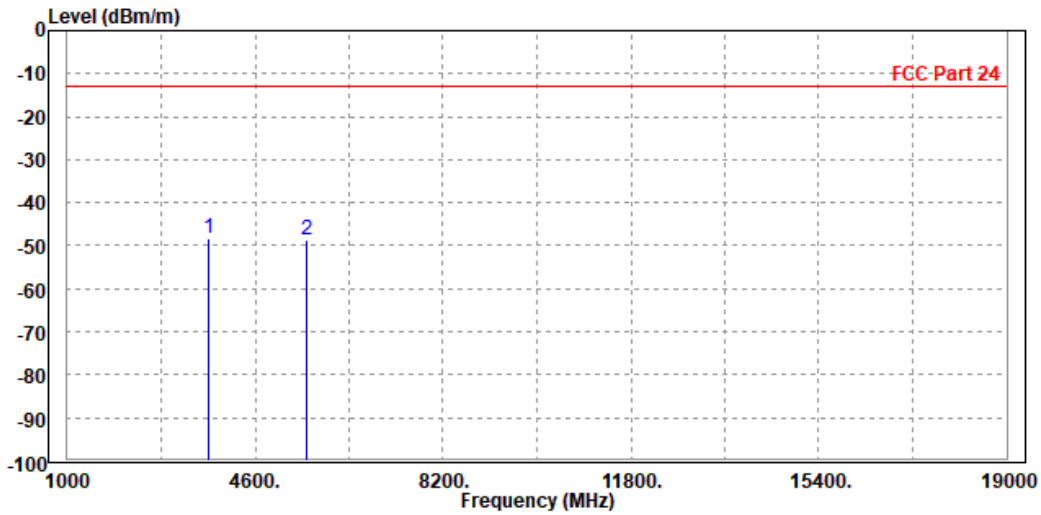



CH 18900

| | | | |
|--|------------------|------------------------|---------------|
| MODE | TX channel 18900 | FREQUENCY RANGE | Above 1000MHz |
| ENVIRONMENTAL CONDITIONS | 23deg. C, 70%RH | INPUT POWER | DC 5V |
| TESTED BY | Tony | | |
| ANTENNA POLARITY & TEST DISTANCE: HORIZONTAL AT 3 M | | | |

| | Freq | Level | Read Level | Limit Line | Over Limit | Factor | Remark | Pol/Phase |
|---|-------------|--------|------------|------------|------------|--------|--------|------------|
| | MHz | dBm/m | dBm | dBm/m | dB | dB/m | | |
| 1 | PP 3754.000 | -33.67 | -42.51 | -13.00 | -20.67 | 8.84 | Peak | Horizontal |
| 2 | 5640.000 | -47.70 | -58.18 | -13.00 | -34.70 | 10.48 | Peak | Horizontal |

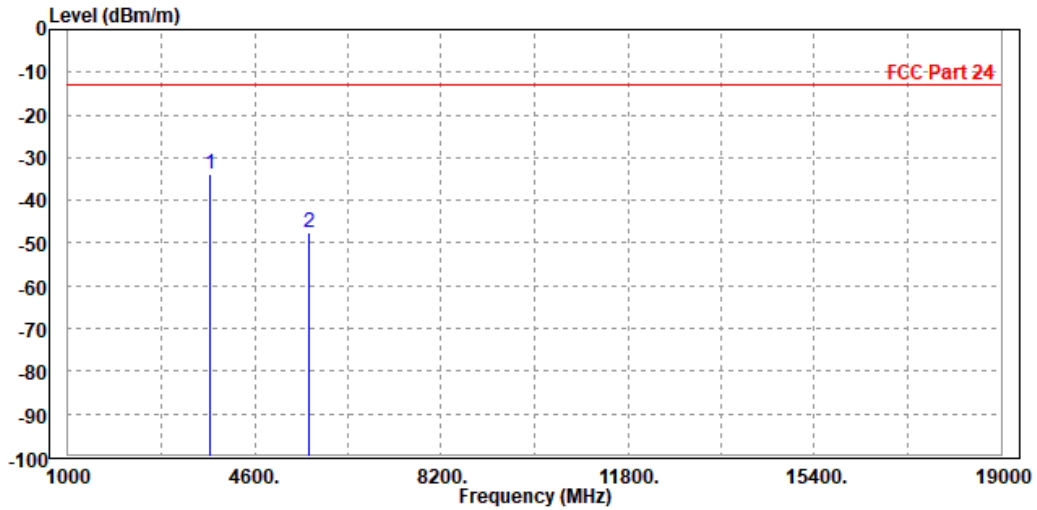



| | | | |
|--|------------------|------------------------|---------------|
| MODE | TX channel 18900 | FREQUENCY RANGE | Above 1000MHz |
| ENVIRONMENTAL CONDITIONS | 23deg. C, 70%RH | INPUT POWER | DC 5V |
| TESTED BY | Tony | | |
| ANTENNA POLARITY & TEST DISTANCE: VERTICAL AT 3 M | | | |

| | Freq | Level | Read Level | Limit Line | Over Limit | Factor | Remark | Pol/Phase |
|------|----------|--------|------------|------------|------------|--------|--------|-----------|
| | MHz | dBm/m | dBm | dBm/m | dB | dB/m | | |
| 1 | 3754.000 | -48.16 | -57.43 | -13.00 | -35.16 | 9.27 | Peak | Vertical |
| 2 PP | 5640.000 | -48.08 | -58.33 | -13.00 | -35.08 | 10.25 | Peak | Vertical |

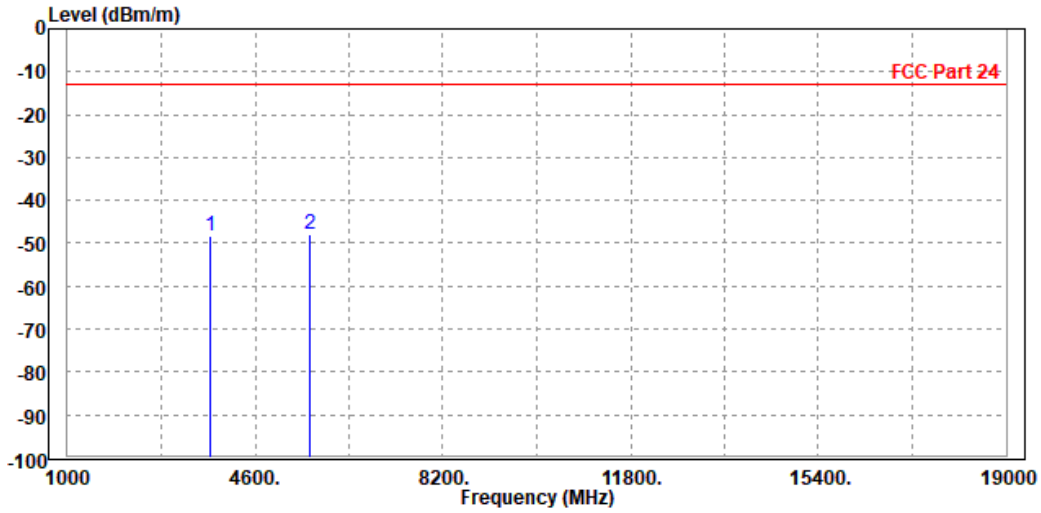



BUREAU VERITAS

Test Report No.: RF200520W003-2

CH 19125

| | | | |
|--|------------------|-----------------|---------------|
| MODE | TX channel 19125 | FREQUENCY RANGE | Above 1000MHz |
| ENVIRONMENTAL CONDITIONS | 23deg. C, 70%RH | INPUT POWER | DC 5V |
| TESTED BY | Tony | | |
| ANTENNA POLARITY & TEST DISTANCE: HORIZONTAL AT 3 M | | | |

| | Freq | Level | Read Level | Limit Line | Over Limit | Factor | Remark | Pol/Phase |
|---|-------------|--------|------------|------------|------------|--------|--------|------------|
| | MHz | dBm/m | dBm | dBm/m | dB | dB/m | | |
| 1 | 3808.000 | -49.79 | -58.69 | -13.00 | -36.79 | 8.90 | Peak | Horizontal |
| 2 | PP 5707.500 | -46.86 | -57.57 | -13.00 | -33.86 | 10.71 | Peak | Horizontal |

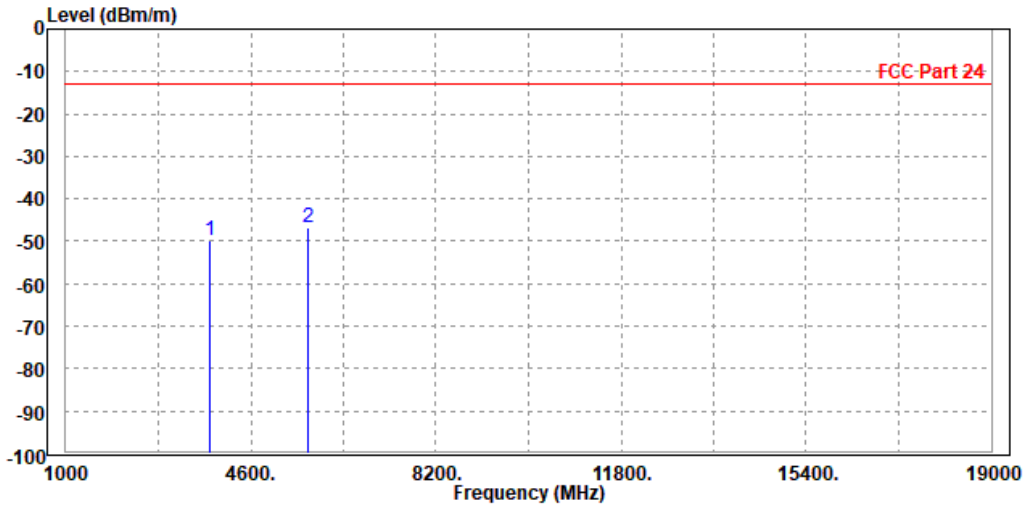



BUREAU VERITAS

Test Report No.: RF200520W003-2

| | | | |
|--|------------------|-----------------|---------------|
| MODE | TX channel 19125 | FREQUENCY RANGE | Above 1000MHz |
| ENVIRONMENTAL CONDITIONS | 23deg. C, 70%RH | INPUT POWER | DC 5V |
| TESTED BY | Tony | | |
| ANTENNA POLARITY & TEST DISTANCE: VERTICAL AT 3 M | | | |

| | Freq | Level | Read Level | Limit Line | Over Limit | Factor | Remark | Pol/Phase |
|------|----------|--------|------------|------------|------------|--------|--------|-----------|
| | MHz | dBm/m | dBm | dBm/m | dB | dB/m | | |
| 1 | 3808.000 | -48.40 | -57.68 | -13.00 | -35.40 | 9.28 | Peak | Vertical |
| 2 PP | 5707.500 | -46.11 | -56.62 | -13.00 | -33.11 | 10.51 | Peak | Vertical |

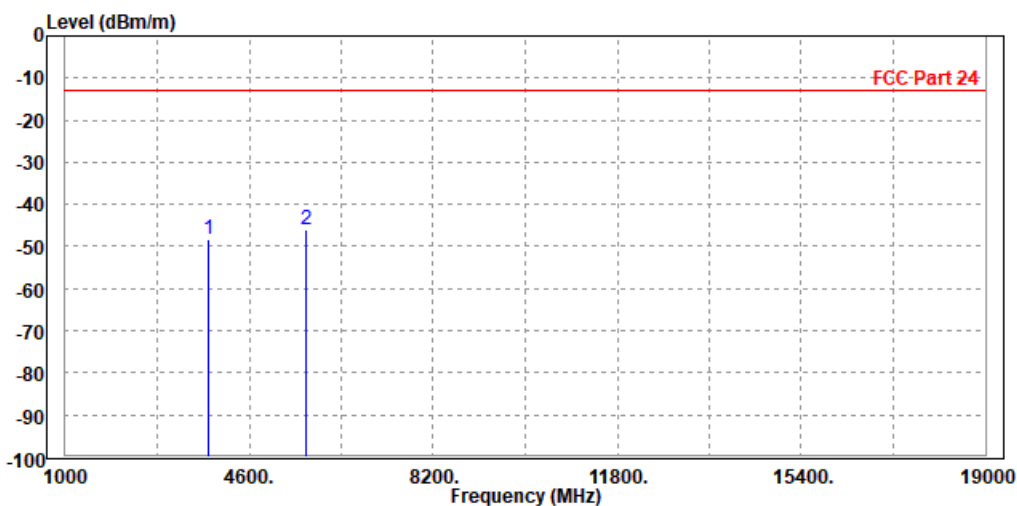



CHANNEL BANDWIDTH: 20MHz / QPSK

| | | | |
|--|------------------|-----------------|---------------|
| MODE | TX channel 18900 | FREQUENCY RANGE | Above 1000MHz |
| ENVIRONMENTAL CONDITIONS | 23deg. C, 70%RH | INPUT POWER | DC 5V |
| TESTED BY | Tony | | |
| ANTENNA POLARITY & TEST DISTANCE: HORIZONTAL AT 3 M | | | |

| | Freq | Level | Read Level | Limit Line | Over Limit | Factor | Remark | Pol/Phase |
|------|----------|--------|------------|------------|------------|--------|--------|------------|
| | MHz | dBm/m | dBm | dBm/m | dB | dB/m | | |
| 1 | 3754.000 | -48.11 | -56.95 | -13.00 | -35.11 | 8.84 | Peak | Horizontal |
| 2 PP | 5640.000 | -48.00 | -58.48 | -13.00 | -35.00 | 10.48 | Peak | Horizontal |

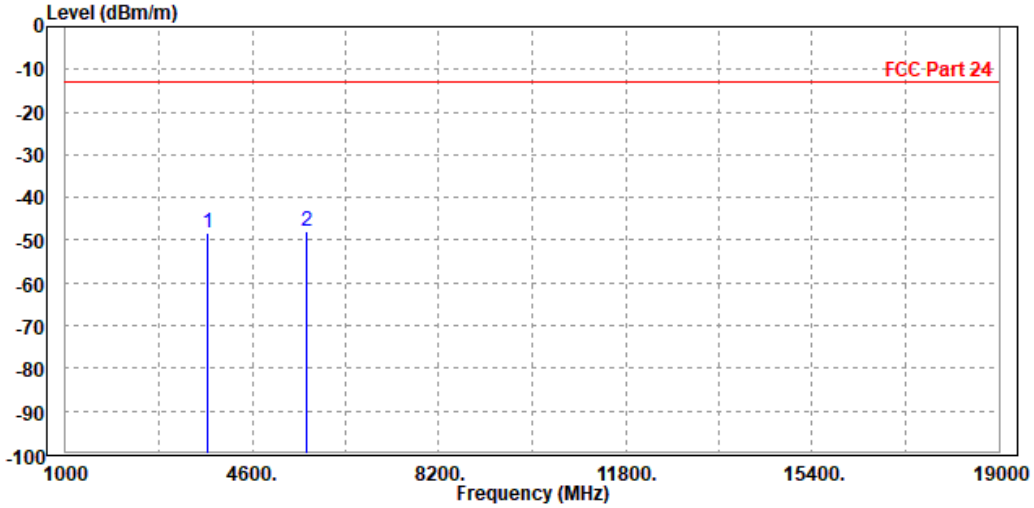



**BUREAU
VERITAS**

Test Report No.: RF200520W003-2

| | | | |
|--|------------------|------------------------|---------------|
| MODE | TX channel 18900 | FREQUENCY RANGE | Above 1000MHz |
| ENVIRONMENTAL CONDITIONS | 23deg. C, 70%RH | INPUT POWER | DC 5V |
| TESTED BY | Tony | | |
| ANTENNA POLARITY & TEST DISTANCE: VERTICAL AT 3 M | | | |

| | Freq | Level | Read Level | Limit Line | Over Limit | Factor | Remark | Pol/Phase |
|---|-------------|--------|------------|------------|------------|--------|--------|-----------|
| | MHz | dBm/m | dBm | dBm/m | dB | dB/m | | |
| 1 | PP 3754.000 | -44.52 | -53.79 | -13.00 | -31.52 | 9.27 | Peak | Vertical |
| 2 | 5640.000 | -47.99 | -58.24 | -13.00 | -34.99 | 10.25 | Peak | Vertical |

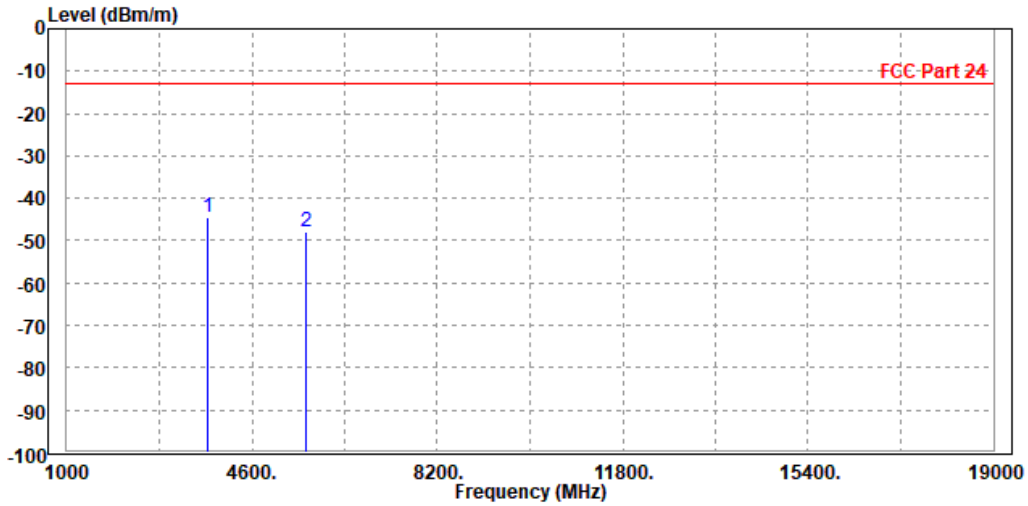



LTE Band 25

CHANNEL BANDWIDTH: 1.4MHz / QPSK

| | | | |
|--|------------------|------------------------|---------------|
| MODE | TX channel 26365 | FREQUENCY RANGE | Above 1000MHz |
| ENVIRONMENTAL CONDITIONS | 23deg. C, 70%RH | INPUT POWER | DC 5V |
| TESTED BY | Tony Xiong | | |
| ANTENNA POLARITY & TEST DISTANCE: HORIZONTAL AT 3 M | | | |

| | Freq | Level | Read Level | Limit Line | Over Limit | Factor | Remark | Pol/Phase |
|---|-------------|--------|------------|------------|------------|--------|--------|------------|
| | MHz | dBm/m | dBm | dBm/m | dB | dB/m | | |
| 1 | PP 3765.000 | -37.91 | -46.77 | -13.00 | -24.91 | 8.86 | Peak | Horizontal |
| 2 | 5654.000 | -42.22 | -52.75 | -13.00 | -29.22 | 10.53 | Peak | Horizontal |

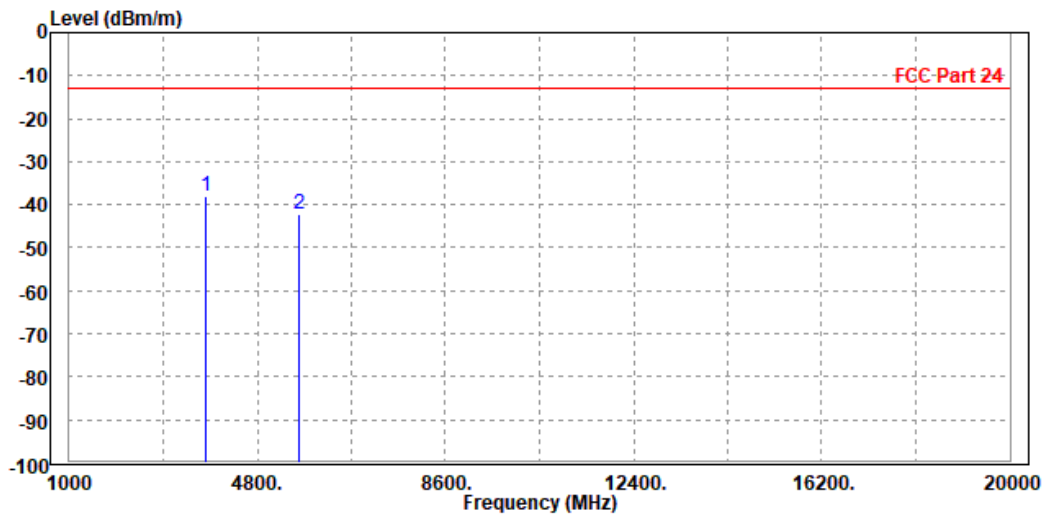



BUREAU VERITAS

Test Report No.: RF200520W003-2

| | | | |
|--|------------------|-----------------|---------------|
| MODE | TX channel 26365 | FREQUENCY RANGE | Above 1000MHz |
| ENVIRONMENTAL CONDITIONS | 23deg. C, 70%RH | INPUT POWER | DC 5V |
| TESTED BY | Tony Xiong | | |
| ANTENNA POLARITY & TEST DISTANCE: VERTICAL AT 3 M | | | |

| | Freq | Level | Read Level | Limit Line | Over Limit | Factor | Remark | Pol/Phase |
|---|-------------|--------|------------|------------|------------|--------|--------|-----------|
| | MHz | dBm/m | dBm | dBm/m | dB | dB/m | | |
| 1 | PP 3756.000 | -33.98 | -43.25 | -13.00 | -20.98 | 9.27 | Peak | Vertical |
| 2 | 5647.500 | -42.11 | -52.39 | -13.00 | -29.11 | 10.28 | Peak | Vertical |

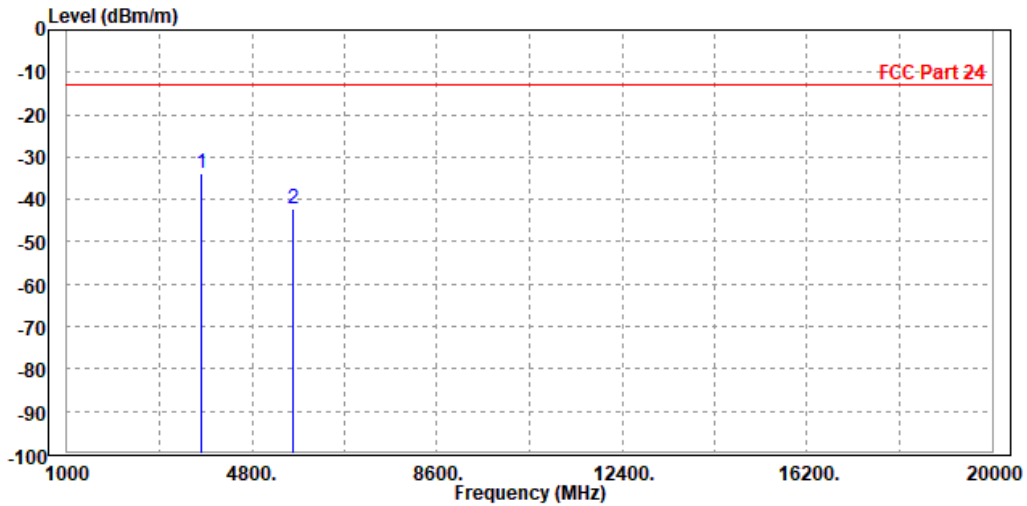



**BUREAU
VERITAS**

Test Report No.: RF200520W003-2

CHANNEL BANDWIDTH: 3MHz / QPSK

CH 26055

| | | | |
|--|------------------|------------------------|---------------|
| MODE | TX channel 26055 | FREQUENCY RANGE | Above 1000MHz |
| ENVIRONMENTAL CONDITIONS | 23deg. C, 70%RH | INPUT POWER | DC 5V |
| TESTED BY | Tony Xiong | | |
| ANTENNA POLARITY & TEST DISTANCE: HORIZONTAL AT 3 M | | | |

| | Freq | Level | Read Level | Limit Line | Over Limit | Factor | Remark | Pol/Phase |
|---|-------------|--------|------------|------------|------------|--------|--------|------------|
| | MHz | dBm/m | dBm | dBm/m | dB | dB/m | | |
| 1 | PP 3704.000 | -33.17 | -41.96 | -13.00 | -20.17 | 8.79 | Peak | Horizontal |
| 2 | 5554.500 | -36.04 | -46.24 | -13.00 | -23.04 | 10.20 | Peak | Horizontal |

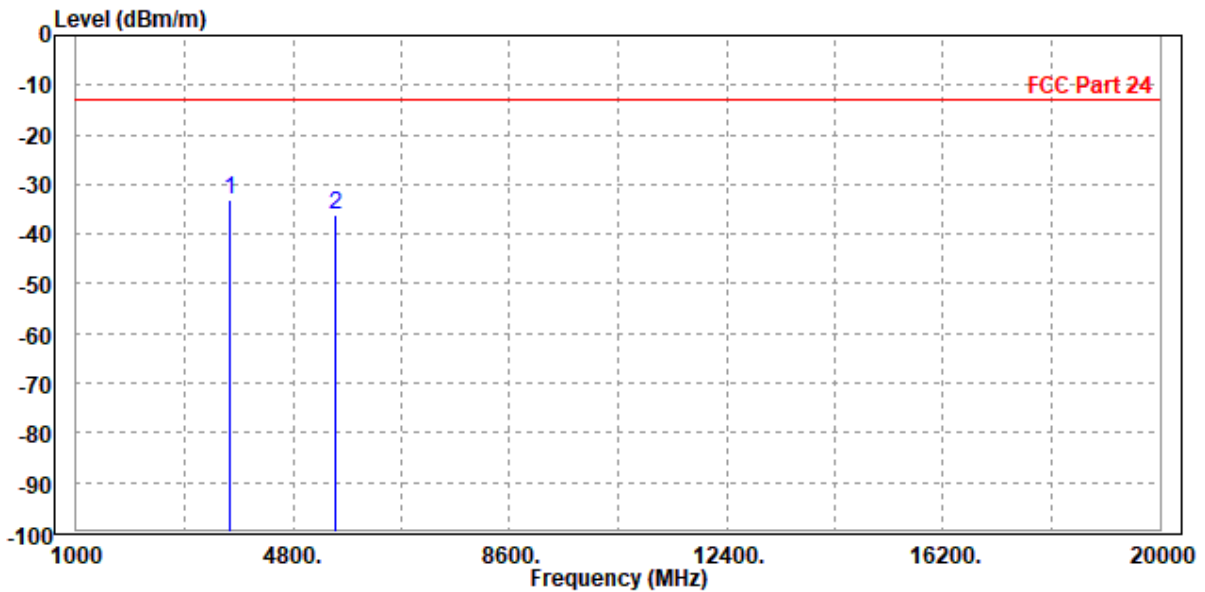



**BUREAU
VERITAS**

Test Report No.: RF200520W003-2

| | | | |
|--|------------------|------------------------|---------------|
| MODE | TX channel 26055 | FREQUENCY RANGE | Above 1000MHz |
| ENVIRONMENTAL CONDITIONS | 23deg. C, 70%RH | INPUT POWER | DC 5V |
| TESTED BY | Tony Xiong | | |
| ANTENNA POLARITY & TEST DISTANCE: VERTICAL AT 3 M | | | |

| | Read | Limit | Over | | | |
|---------------|--------|--------|--------|--------|--------|---------------|
| Freq | Level | Level | Line | Limit | Factor | Remark |
| MHz | dBm/m | dBm | dBm/m | dB | dB/m | Pol/Phase |
| 1 PP 3703.000 | -30.80 | -40.05 | -13.00 | -17.80 | 9.25 | Peak Vertical |
| 2 5550.000 | -38.80 | -48.70 | -13.00 | -25.80 | 9.90 | Peak Vertical |

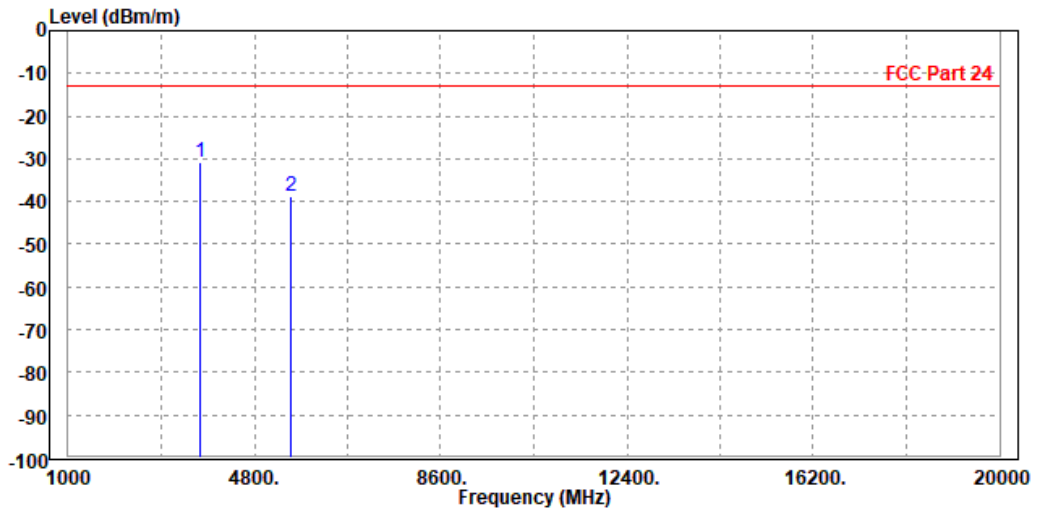



CH 26365

| | | | |
|--|------------------|-----------------|---------------|
| MODE | TX channel 26365 | FREQUENCY RANGE | Above 1000MHz |
| ENVIRONMENTAL CONDITIONS | 23deg. C, 70%RH | INPUT POWER | DC 5V |
| TESTED BY | Tony Xiong | | |
| ANTENNA POLARITY & TEST DISTANCE: HORIZONTAL AT 3 M | | | |

| | Freq | Level | Read Level | Limit Line | Over Limit | Factor | Remark | Pol/Phase |
|---|-------------|--------|------------|------------|------------|--------|--------|------------|
| | MHz | dBm/m | dBm | dBm/m | dB | dB/m | | |
| 1 | PP 3756.000 | -38.70 | -47.55 | -13.00 | -25.70 | 8.85 | Peak | Horizontal |
| 2 | 5647.500 | -45.05 | -55.56 | -13.00 | -32.05 | 10.51 | Peak | Horizontal |

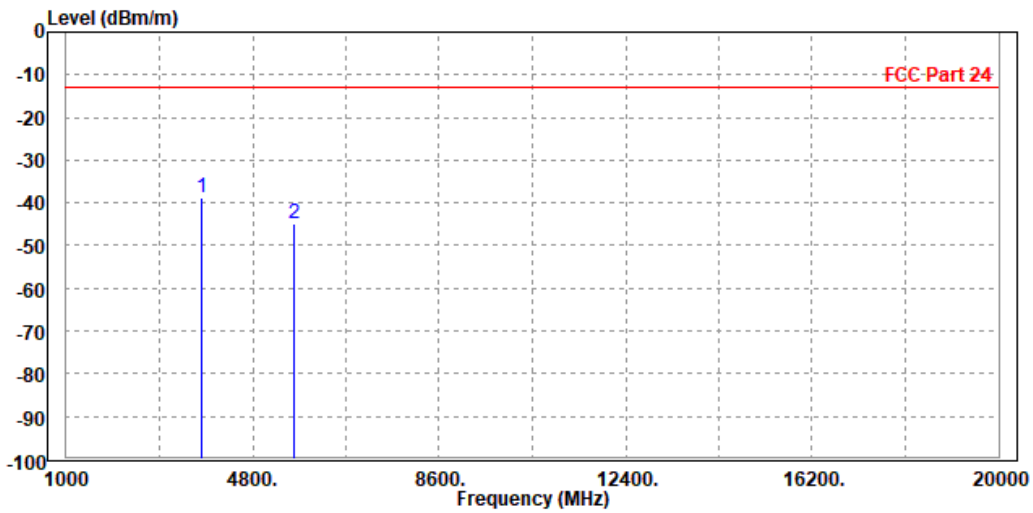



BUREAU VERITAS

Test Report No.: RF200520W003-2

| | | | |
|--|------------------|-----------------|---------------|
| MODE | TX channel 26365 | FREQUENCY RANGE | Above 1000MHz |
| ENVIRONMENTAL CONDITIONS | 23deg. C, 70%RH | INPUT POWER | DC 5V |
| TESTED BY | Tony Xiong | | |
| ANTENNA POLARITY & TEST DISTANCE: VERTICAL AT 3 M | | | |

| | Freq | Level | Read Level | Limit Line | Over Limit | Factor | Remark | Pol/Phase |
|---|-------------|--------|------------|------------|------------|--------|--------|-----------|
| | MHz | dBm/m | dBm | dBm/m | dB | dB/m | | |
| 1 | PP 3765.000 | -35.34 | -44.61 | -13.00 | -22.34 | 9.27 | Peak | Vertical |
| 2 | 5654.000 | -45.19 | -55.49 | -13.00 | -32.19 | 10.30 | Peak | Vertical |

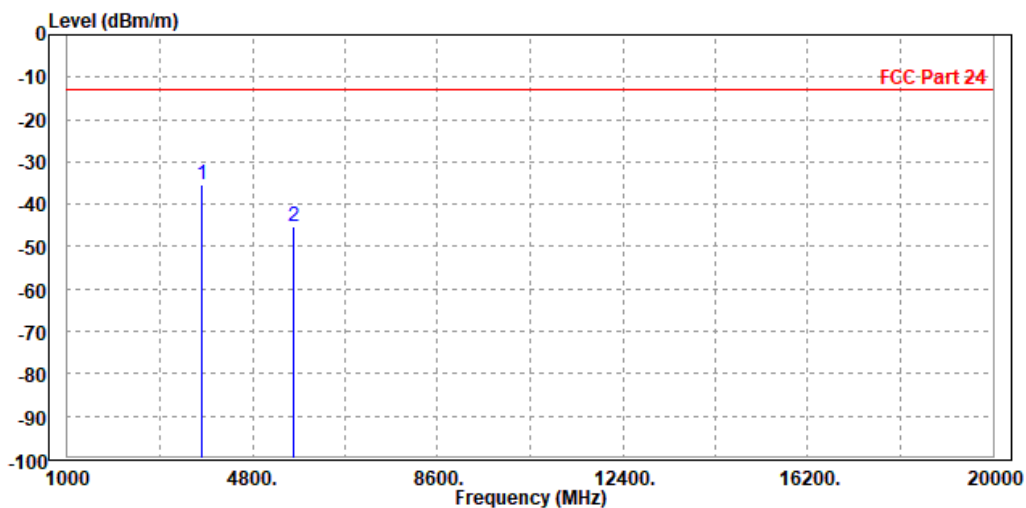



CH 26675

| | | | |
|---|------------------|-----------------|---------------|
| MODE | TX channel 26675 | FREQUENCY RANGE | Above 1000MHz |
| ENVIRONMENTAL CONDITIONS | 23deg. C, 70%RH | INPUT POWER | DC 5V |
| TESTED BY | Tony Xiong | | |
| ANTENNA POLARITY & TEST DISTANCE: HORIZONTAL AT 3 M | | | |

| | Freq | Level | Read Level | Limit Line | Over Limit | Factor | Remark | Pol/Phase |
|---|-------------|--------|------------|------------|------------|--------|--------|------------|
| | MHz | dBm/m | dBm | dBm/m | dB | dB/m | | |
| 1 | PP 3827.000 | -43.19 | -52.11 | -13.00 | -30.19 | 8.92 | Peak | Horizontal |
| 2 | 5732.000 | -46.20 | -56.99 | -13.00 | -33.20 | 10.79 | Peak | Horizontal |

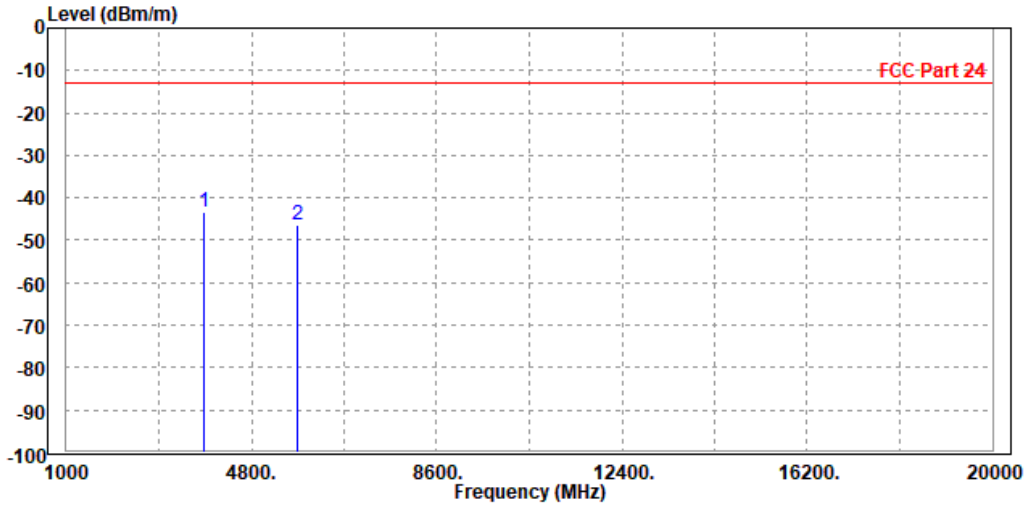



BUREAU VERITAS

Test Report No.: RF200520W003-2

| | | | |
|--|------------------|-----------------|---------------|
| MODE | TX channel 26675 | FREQUENCY RANGE | Above 1000MHz |
| ENVIRONMENTAL CONDITIONS | 23deg. C, 70%RH | INPUT POWER | DC 5V |
| TESTED BY | Tony Xiong | | |
| ANTENNA POLARITY & TEST DISTANCE: VERTICAL AT 3 M | | | |

| | Freq | Level | Read Level | Limit Line | Over Limit | Factor | Remark | Pol/Phase |
|---|-------------|--------|------------|------------|------------|--------|--------|-----------|
| | MHz | dBm/m | dBm | dBm/m | dB | dB/m | | |
| 1 | PP 3834.000 | -43.08 | -52.37 | -13.00 | -30.08 | 9.29 | Peak | Vertical |
| 2 | 5740.500 | -46.86 | -57.50 | -13.00 | -33.86 | 10.64 | Peak | Vertical |

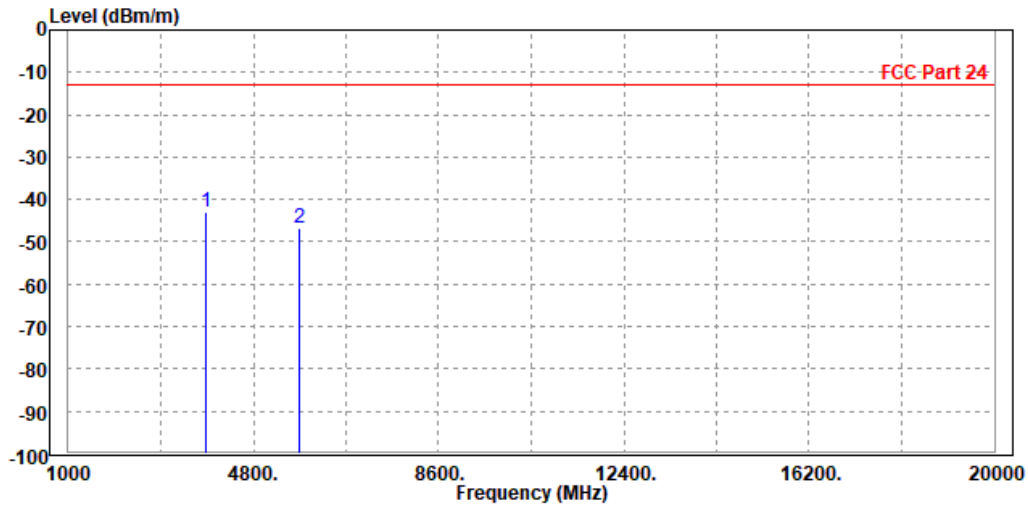



CHANNEL BANDWIDTH: 5MHz / QPSK

| | | | |
|--|------------------|-----------------|---------------|
| MODE | TX channel 26365 | FREQUENCY RANGE | Above 1000MHz |
| ENVIRONMENTAL CONDITIONS | 23deg. C, 70%RH | INPUT POWER | DC 5V |
| TESTED BY | Tony Xiong | | |
| ANTENNA POLARITY & TEST DISTANCE: HORIZONTAL AT 3 M | | | |

| | Freq | Level | Read Level | Limit Line | Over Limit | Factor | Remark | Pol/Phase |
|---|-------------|--------|------------|------------|------------|--------|--------|------------|
| | MHz | dBm/m | dBm | dBm/m | dB | dB/m | | |
| 1 | PP 3765.000 | -37.14 | -46.00 | -13.00 | -24.14 | 8.86 | Peak | Horizontal |
| 2 | 5654.000 | -42.05 | -52.58 | -13.00 | -29.05 | 10.53 | Peak | Horizontal |

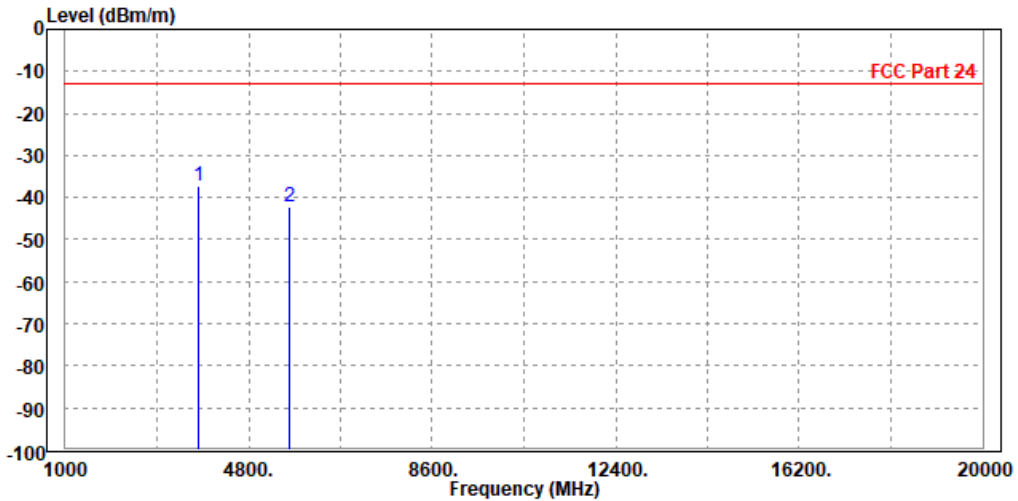



| | | | |
|--|------------------|-----------------|---------------|
| MODE | TX channel 26365 | FREQUENCY RANGE | Above 1000MHz |
| ENVIRONMENTAL CONDITIONS | 23deg. C, 70%RH | INPUT POWER | DC 5V |
| TESTED BY | Tony Xiong | | |
| ANTENNA POLARITY & TEST DISTANCE: VERTICAL AT 3 M | | | |

| | Read | Limit | Over | | | | |
|---------------|--------|--------|--------|--------|--------|--------|-----------|
| Freq | Level | Level | Line | Limit | Factor | Remark | Pol/Phase |
| MHz | dBm/m | dBm | dBm/m | dB | dB/m | | |
| 1 PP 3756.000 | -35.82 | -45.09 | -13.00 | -22.82 | 9.27 | Peak | Vertical |
| 2 5647.500 | -41.63 | -51.91 | -13.00 | -28.63 | 10.28 | Peak | Vertical |

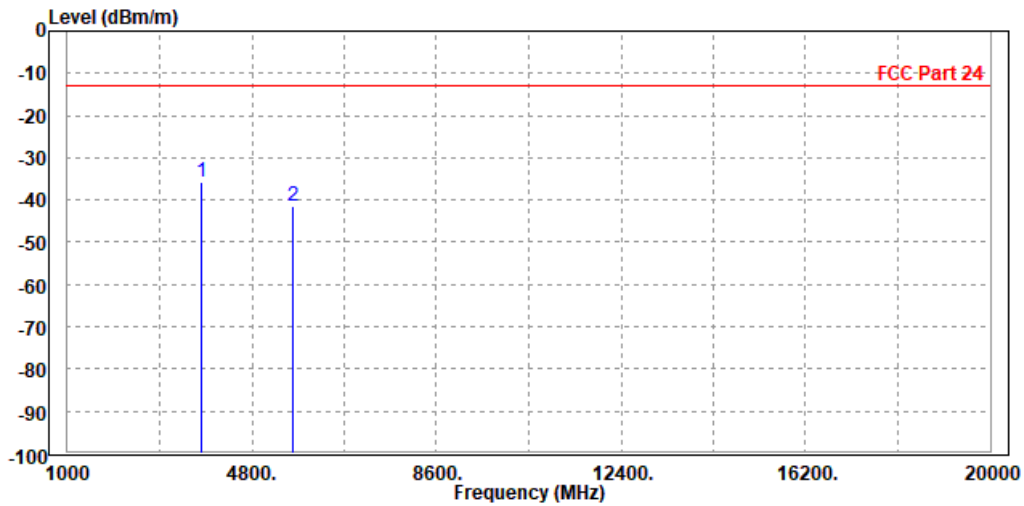



CHANNEL BANDWIDTH: 10MHz / QPSK

| | | | |
|--|------------------|-----------------|---------------|
| MODE | TX channel 26365 | FREQUENCY RANGE | Above 1000MHz |
| ENVIRONMENTAL CONDITIONS | 23deg. C, 70%RH | INPUT POWER | DC 5V |
| TESTED BY | Tony Xiong | | |
| ANTENNA POLARITY & TEST DISTANCE: HORIZONTAL AT 3 M | | | |

| | Freq | Level | Read Level | Limit Line | Over Limit | Factor | Remark | Pol/Phase |
|------|----------|--------|------------|------------|------------|--------|--------|------------|
| | MHz | dBm/m | dBm | dBm/m | dB | dB/m | | |
| 1 PP | 3765.000 | -38.93 | -47.79 | -13.00 | -25.93 | 8.86 | Peak | Horizontal |
| 2 | 5654.000 | -43.03 | -53.56 | -13.00 | -30.03 | 10.53 | Peak | Horizontal |

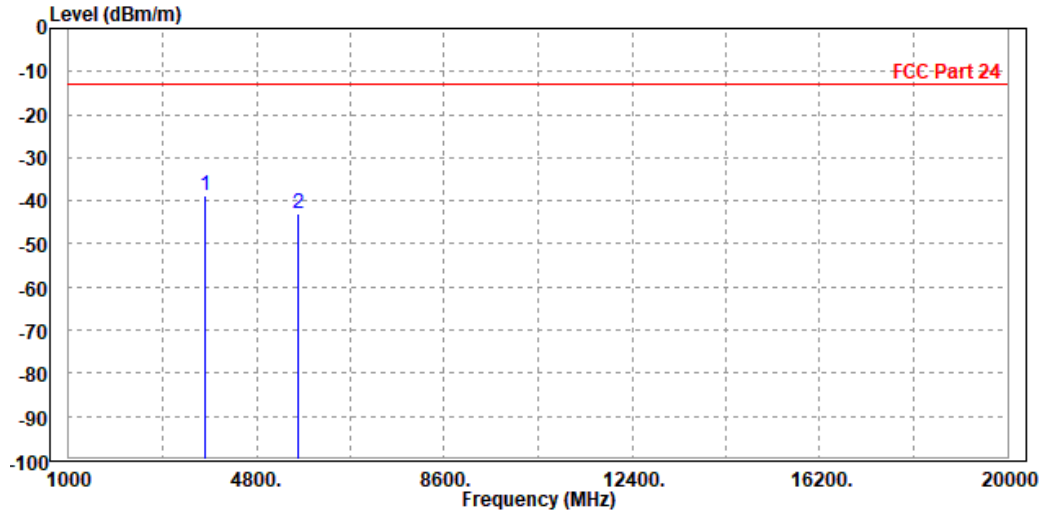



BUREAU VERITAS

Test Report No.: RF200520W003-2

| | | | |
|--|------------------|-----------------|---------------|
| MODE | TX channel 26365 | FREQUENCY RANGE | Above 1000MHz |
| ENVIRONMENTAL CONDITIONS | 23deg. C, 70%RH | INPUT POWER | DC 5V |
| TESTED BY | Tony Xiong | | |
| ANTENNA POLARITY & TEST DISTANCE: VERTICAL AT 3 M | | | |

| | Freq | Level | Read Level | Limit Line | Over Limit | Factor | Remark | Pol/Phase |
|---|-------------|--------|------------|------------|------------|--------|--------|-----------|
| | MHz | dBm/m | dBm | dBm/m | dB | dB/m | | |
| 1 | PP 3756.000 | -35.49 | -44.76 | -13.00 | -22.49 | 9.27 | Peak | Vertical |
| 2 | 5647.500 | -47.85 | -58.13 | -13.00 | -34.85 | 10.28 | Peak | Vertical |

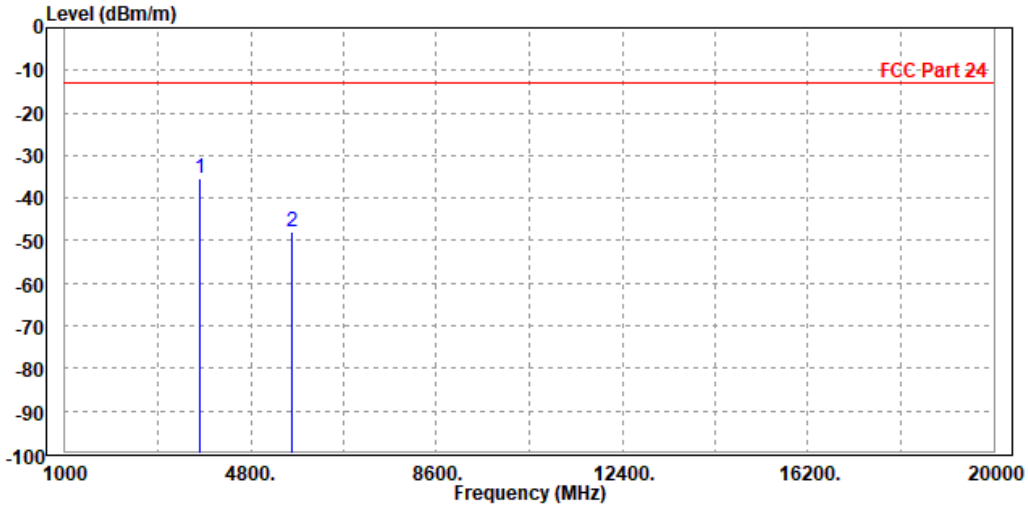



**BUREAU
VERITAS**

Test Report No.: RF200520W003-2

CHANNEL BANDWIDTH: 15MHz / QPSK

| | | | |
|--|------------------|------------------------|---------------|
| MODE | TX channel 26365 | FREQUENCY RANGE | Above 1000MHz |
| ENVIRONMENTAL CONDITIONS | 23deg. C, 70%RH | INPUT POWER | DC 5V |
| TESTED BY | Tony Xiong | | |
| ANTENNA POLARITY & TEST DISTANCE: HORIZONTAL AT 3 M | | | |

| | Freq | Level | Read Level | Limit Line | Over Limit | Factor | Remark | Pol/Phase |
|---|-------------|--------|------------|------------|------------|--------|--------|------------|
| | MHz | dBm/m | dBm | dBm/m | dB | dB/m | | |
| 1 | PP 3756.000 | -42.48 | -51.33 | -13.00 | -29.48 | 8.85 | Peak | Horizontal |
| 2 | 5647.500 | -44.29 | -54.80 | -13.00 | -31.29 | 10.51 | Peak | Horizontal |

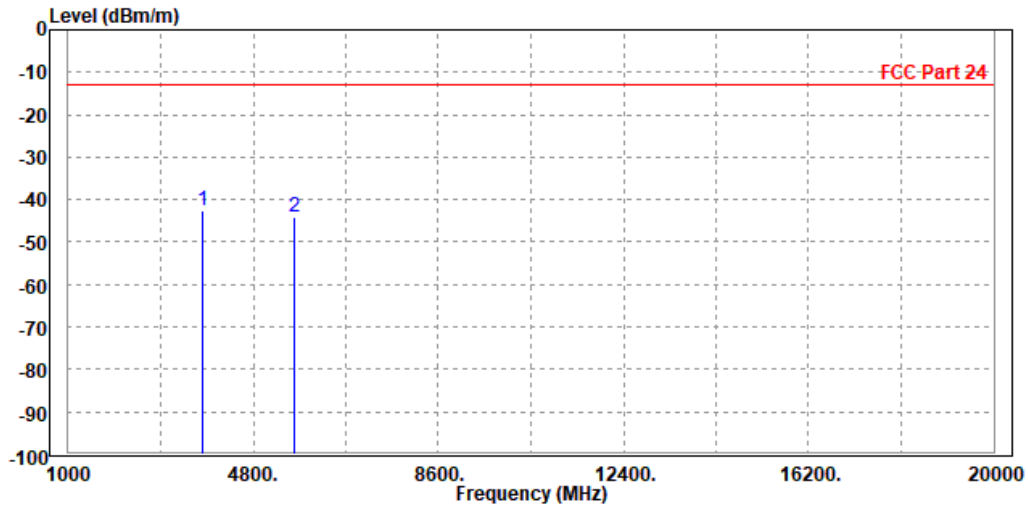



| | | | |
|--|------------------|------------------------|---------------|
| MODE | TX channel 26365 | FREQUENCY RANGE | Above 1000MHz |
| ENVIRONMENTAL CONDITIONS | 23deg. C, 70%RH | INPUT POWER | DC 5V |
| TESTED BY | Tony Xiong | | |
| ANTENNA POLARITY & TEST DISTANCE: VERTICAL AT 3 M | | | |

| | Read | Limit | Over | | | | |
|---------------|--------|--------|--------|--------|--------|--------|-----------|
| Freq | Level | Level | Line | Limit | Factor | Remark | Pol/Phase |
| MHz | dBm/m | dBm | dBm/m | dB | dB/m | | |
| 1 PP 3765.000 | -35.40 | -44.67 | -13.00 | -22.40 | 9.27 | Peak | Vertical |
| 2 5654.000 | -48.11 | -58.41 | -13.00 | -35.11 | 10.30 | Peak | Vertical |

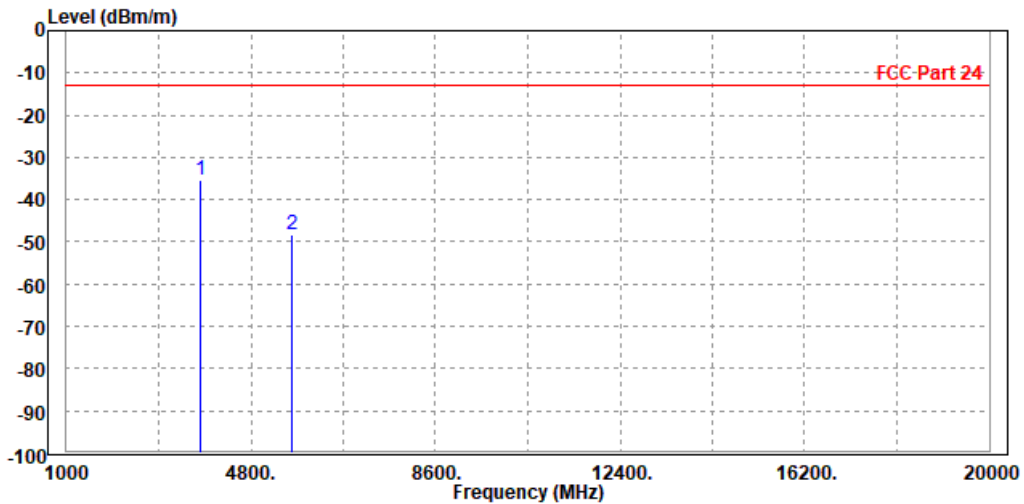



CHANNEL BANDWIDTH: 20MHz / QPSK

| | | | |
|--|------------------|-----------------|---------------|
| MODE | TX channel 26365 | FREQUENCY RANGE | Above 1000MHz |
| ENVIRONMENTAL CONDITIONS | 23deg. C, 70%RH | INPUT POWER | DC 5V |
| TESTED BY | Tony Xiong | | |
| ANTENNA POLARITY & TEST DISTANCE: HORIZONTAL AT 3 M | | | |

| | Freq | Level | Read Level | Limit Line | Over Limit | Factor | Remark | Pol/Phase |
|---|-------------|--------|------------|------------|------------|--------|--------|------------|
| | MHz | dBm/m | dBm | dBm/m | dB | dB/m | | |
| 1 | PP 3765.000 | -38.17 | -47.03 | -13.00 | -25.17 | 8.86 | Peak | Horizontal |
| 2 | 5654.000 | -47.80 | -58.33 | -13.00 | -34.80 | 10.53 | Peak | Horizontal |

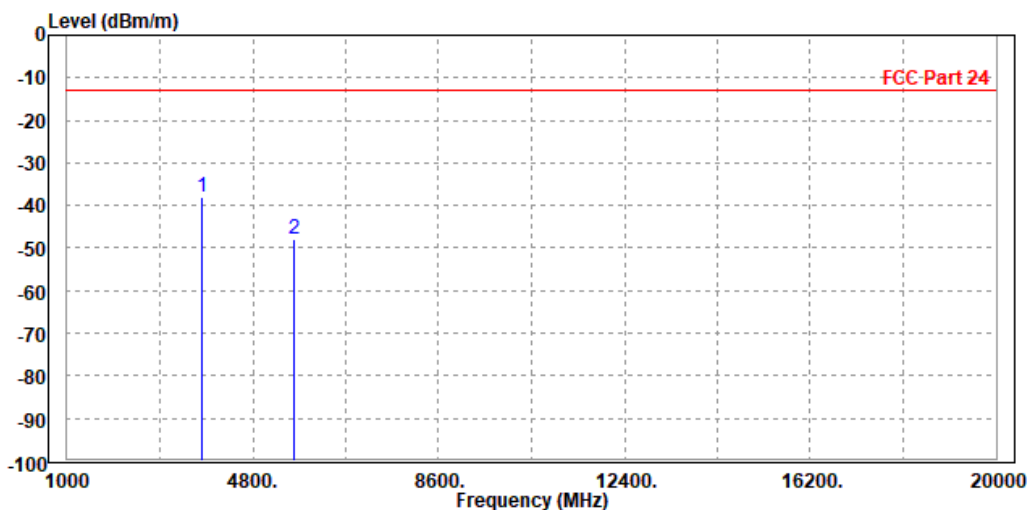



**BUREAU
VERITAS**

Test Report No.: RF200520W003-2

| | | | |
|--|------------------|------------------------|---------------|
| MODE | TX channel 26365 | FREQUENCY RANGE | Above 1000MHz |
| ENVIRONMENTAL CONDITIONS | 23deg. C, 70%RH | INPUT POWER | DC 5V |
| TESTED BY | Tony Xiong | | |
| ANTENNA POLARITY & TEST DISTANCE: VERTICAL AT 3 M | | | |

| | Freq | Level | Read Level | Limit Line | Over Limit | Factor | Remark | Pol/Phase |
|---|-------------|--------|------------|------------|------------|--------|--------|-----------|
| | MHz | dBm/m | dBm | dBm/m | dB | dB/m | | |
| 1 | PP 3756.000 | -35.66 | -44.93 | -13.00 | -22.66 | 9.27 | Peak | Vertical |
| 2 | 5647.500 | -48.18 | -58.46 | -13.00 | -35.18 | 10.28 | Peak | Vertical |

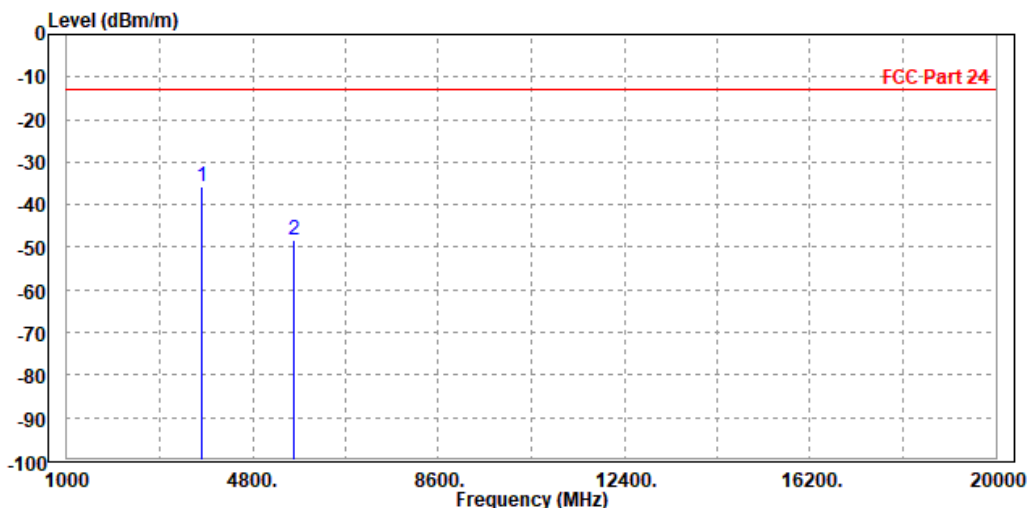



3.7 PEAK TO AVERAGE RATIO

3.7.1 LIMITS OF peak to average ratio MEASUREMENT

In measuring transmissions in this band using an average power technique, the peak to-average ratio (PAR) of the transmission may not exceed 13 dB

3.7.2 TEST SETUP

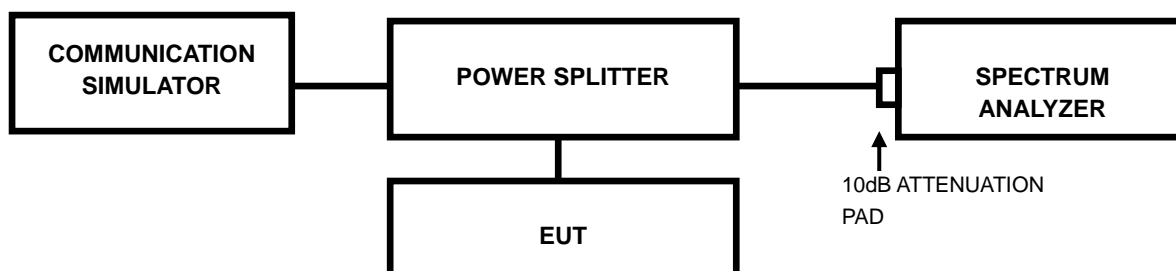

3.7.3 TEST PROCEDURES

1. Set resolution/measurement bandwidth \geq signal's occupied bandwidth;
2. Set the number of counts to a value that stabilizes the measured CCDF curve;
3. Record the maximum PAPR level associated with a probability of 0.1%.

3.7.4 TEST RESULTS

The test results was recorded in Report No.: R1811A0536-R2(FCC ID: XMR201707BG96).



BUREAU VERITAS Test Report No.: RF200520W003-2

4 INFORMATION ON THE TESTING LABORATORIES

We, BV 7LAYERS COMMUNICATIONS TECHNOLOGY (SHENZHEN) CO. LTD., were founded in 2015 to provide our best service in EMC, Radio, Telecom and Safety consultation. Our laboratories are accredited and approved according to ISO/IEC 17025.

If you have any comments, please feel free to contact us at the following:

Shenzhen EMC/RF Lab:

Tel: +86-755-88696566

Fax: +86-755-88696577

Email: customerservice.dg@cn.bureauveritas.com

Web Site: www.adt.com.tw

The address and road map of all our labs can be found in our web site also.



BUREAU VERITAS Test Report No.: RF200520W003-2

5 APPENDIX A – MODIFICATIONS RECORDERS FOR ENGINEERING CHANGES TO THE EUT BY THE LAB

No any modifications are made to the EUT by the lab during the test.

---END---