



JAPAN TEST REPORT

Report No:STS1903107W01

Issued for

Particle Industries, Inc

126 Post St, 4th floor, San Francisco, CA 94108 USA

| | |
|-------------------------|--|
| Product Name: | Xenon |
| Brand Name: | N/A |
| Test Model Name: | XENN |
| Series Model: | N/A |
| Test Standard: | Article 2 Paragraph 1 of Item 19, annex 43 and annex 1 |

Any reproduction of this document must be done in full. No single part of this document may be reproduced without permission from STS, All Test Data Presented in this report is only applicable to presented Test sample.





TEST RESULT CERTIFICATION

Applicant's name : Particle Industries, Inc
Address..... : 126 Post St, 4th floor, San Francisco, CA 94108 USA
Manufacture's Name : ABO Electronics (Shenzhen) Co., Ltd
Address..... : 2nd Floor, Building A, Block D, 99 Ind Zone, Minzhu, XiHuan Road, Shajing, Baoan, Shenzhen, PRC

Test specification:

Standard : Article 2 Paragraph 1 of Item 19, annex 43 and annex 1

Product description

Product name..... : Xenon
 Trade mark..... : N/A
 Test model name..... : XENN
 Series model..... : N/A

This device described above has been tested by STS, the test results show that the equipment under test (EUT) is in compliance with Article 2 Paragraph 1 of Item 19, annex 43 and annex 1 requirements. And it is applicable only to the tested sample identified in the report.

This report shall not be reproduced except in full, without the written approval of STS, this document may be altered or revised by STS, personal only, and shall be noted in the revision of the document

Testing

Date of receipt of test item : 04 Mar. 2019
 Date (s) of performance of tests : 04 Mar. 2019 ~ 19 Mar. 2019
 Date of Issue : 21 Mar. 2019
 Test Result : **Pass**

Testing Engineer : 

 (Chris chen)

Technical Manager : 

 (Sunday Hu)

Authorized Signatory : 

 (Vita Li)





| Table of Contents | Page |
|---|-----------|
| 1 . SUMMARY OF TEST RESULTS | 6 |
| 1.1 TEST FACTORY | 7 |
| 1.2 MEASUREMENT UNCERTAINTY | 7 |
| 2. GENERAL INFORMATION | 8 |
| 2.1 GENERAL DESCRIPTION OF THE EUT | 8 |
| 2.2 DESCRIPTION OF THE TEST MODES | 10 |
| 2.3 TEST CONDITIONS | 10 |
| 2.4 BLOCK DIGRAM SHOWING THE CONFIGURATION OF SYSTEM TESTED | 11 |
| 2.5 DESCRIPTION OF NECESSARY ACCESSORIES AND SUPPORT UNITS | 11 |
| 2.6 EQUIPMENTS LIST FOR ALL TEST ITEMS | 12 |
| 3. CONSTRUCTION PROTECTION CONFIRMATION | 13 |
| 4. FREQUENCY ERROR | 14 |
| 4.1 LIMIT | 14 |
| 4. 2 TEST PROCEDURES | 14 |
| 4.3 TEST SETUP | 14 |
| 4.4 EUT OPERATION DURING TEST | 14 |
| 4.5 TEST RESULT | 15 |
| 5. ANTENNA POWER | 18 |
| 5.1 LIMIT | 18 |
| 5.2 TEST PROCEDURE | 18 |
| 5.3 TEST SETUP | 18 |
| 5.4 TEST DEVIATION | 18 |
| 5.5 TEST RESULT | 19 |
| 6. RADIATION POWER | 20 |
| 6.1 LIMIT | 20 |
| 6.2 TEST RESULT | 20 |
| 7. OCCUPIED BANDWITH AND SPREAD BANDWIDTH | 21 |
| 7.1 LIMIT | 21 |
| 7.2 TEST PROCEDURES | 21 |
| 7.3 TEST SETUP | 21 |
| 7.4 TEST DEVIATION | 21 |
| 7.5 EUT OPERATION DURING TEST | 21 |
| 8. UNWANTED EMISSION INTENSITY MEASUREMENT | 26 |



| | |
|---|-----------|
| 8.1 LIMIT | 26 |
| 8.2 TEST PROCEDURES | 26 |
| 8.3 TEST SETUP | 27 |
| 8.4 TEST DEVIATION | 27 |
| 8.5 TEST RESULT | 28 |
| 9. IMITATION OF COLLATERAL EMISSION OF RECEIVER MEASUREMENT | 33 |
| 9.1 LIMIT | 33 |
| 9.2 TEST PROCEDURES | 33 |
| 9.3 TEST RESULT | 34 |
| 10. TRANSMISSION RADIATION ANGLE WIDTH (3DB BEAMWIDTH) MEASUREMENT | 35 |
| 10.1 LIMIT | 35 |
| 10.2 TEST PROCEDURES | 35 |
| 10.3 TEST SETUP | 36 |
| 10.4 TEST DEVIATION | 36 |
| 10.5 EUT OPERATION DURING TEST | 36 |
| 10.6 TEST RESULT | 36 |
| 11. RADIO INTERFERENCE PREVENTION CAPABILITY MEASUREMENT | 37 |
| 11.1 LIMIT | 37 |
| 11.2 MEASURING ID CODE SOFTWARE | 37 |
| 11.3 TEST PROCEDURES | 37 |
| 11.4 TEST SETUP | 37 |
| 11.5 TEST DEVIATION | 37 |
| 11.6 EUT OPERATION DURING TEST | 37 |
| 11.7 TEST RESULT OF RADIO INTERFERENCE PREVENTION CAPABILIT | 38 |
| 12. CARRIER SENSE CAPABILITY | 39 |
| 12.1 INTERFERENCE PREVENTION FUNCTION | 39 |
| 12.2 TEST REQUIREMENT | 39 |
| 12.3 TEST PROCEDURE | 39 |
| 12.4 TEST RESULT | 39 |



Revision History

| Rev. | Issue Date | Report NO. | Effect Page | Contents |
|------|--------------|---------------|-------------|---------------|
| 00 | 21 Mar. 2019 | STS1903107W01 | ALL | Initial Issue |
| | | | | |





1. SUMMARY OF TEST RESULTS

Test procedures according to the technical standards: STD-T66 V3.7

| Rule Section | Description of Test | Result | judgement |
|--------------|---|------------------------|-----------|
| 3.2 | Frequency Error | -3.831ppm | PASS |
| 3.2 | Occupied Bandwidth (99%) Spread-spectrum Bandwidth (90%) | 1.0740MHz 0.704 MHz | PASS |
| 3.2 | Unwanted Emission Intensity | -- | PASS |
| 3.2 | Power Error | -55.30% | PASS |
| 3.3 | Limitation of Collateral Emission of Receiver | -- | PASS |
| 3.6 | Transmission Radiation power | N/A | N/A |
| 3.2 | Transmission Radiation Angle Width (3DB Beamwidth) | N/A | N/A |
| 3.4 | Radio Interference Prevention Capability | -- | PASS |
| 3.2 | Spreading Factor | N/A | N/A |
| Note(2) | Carrier Sense Capability | N/A | N/A |
| 3.7 | Construction Protection Confirmation | -- | PASS |

NOTE:

- (1) "N/A" denotes test is not applicable in this Test Report
- (2) Article 2 Paragraph 1 of Item 19, annex 43 and annex 1
- (3) Section 4.17 Radio Equipment of Radio Stations of a Low-Power Data Communication System (Article 49.20)



1.1 TEST FACTORY

Shenzhen STS Test Services Co., Ltd.

Add. : 1/F., Building B, Zhuoke Science Park, No.190, Chongqing Road,
Fuyong Street, Bao'an District, Shenzhen, Guangdong, China

FCC Registration No.: 625569

A2LA Certificate No.: 4338.01

1.2 MEASUREMENT UNCERTAINTY

The reported uncertainty of measurement $y \pm U$ · where expanded uncertainty U is based on a standard uncertainty multiplied by a coverage factor of $k=2$ · providing a level of confidence of approximately **95 %** °

| No. | Item | Uncertainty |
|-----|-------------------------------|---------------------|
| 1 | RF output power, conducted | $\pm 0.71\text{dB}$ |
| 2 | Unwanted Emissions, conducted | $\pm 0.63\text{dB}$ |



2. GENERAL INFORMATION

2.1 GENERAL DESCRIPTION OF THE EUT

| | | |
|--|--|---|
| Equipment | Xenon | |
| Brand Name | N/A | |
| Model Name | XENN | |
| Series Model | XXXXXX | |
| Model Difference | N/A | |
| Product Description | The EUT is Xenon | |
| | Operation Frequency: | 2402~2480 MHz |
| | Modulation Type: | GFSK |
| | Number Of Channel: | 40CH |
| | Antenna Designation: | Antenna A: PCB Antenna Antenna B: PIFA Antenna |
| | Antenna Gain(Peak): | Antenna A: 0 dBi Antenna B: 2 dBi |
| Based on the application, features, or specification exhibited in User's Manual, the EUT is considered as an ITE/Computing Device. More details of EUT technical specification, please refer to the User's Manual. | | |
| Channel List | Please refer to the Note 2. | |
| Battery | Rated Voltage: 3.7V Capacity: 1800mAh, 6.66Wh | |
| Hardware version | N/A | |
| Software version | N/A | |

Note:

1. For a more detailed features description, please refer to the manufacturer's specifications or the User's Manual.



2

| Channel List for BLE | | | | | | | |
|----------------------|-----------------|---------|-----------------|---------|-----------------|---------|-----------------|
| Channel | Frequency (MHz) | Channel | Frequency (MHz) | Channel | Frequency (MHz) | Channel | Frequency (MHz) |
| 37 | 2402 | 09 | 2422 | 18 | 2442 | 28 | 2462 |
| 00 | 2404 | 10 | 2424 | 19 | 2444 | 29 | 2464 |
| 01 | 2406 | 38 | 2426 | 20 | 2446 | 30 | 2466 |
| 02 | 2408 | 11 | 2428 | 21 | 2448 | 31 | 2468 |
| 03 | 2410 | 12 | 2430 | 22 | 2450 | 32 | 2470 |
| 04 | 2412 | 13 | 2432 | 23 | 2452 | 33 | 2472 |
| 05 | 2414 | 14 | 2434 | 24 | 2454 | 34 | 2474 |
| 06 | 2416 | 15 | 2436 | 25 | 2456 | 35 | 2476 |
| 07 | 2418 | 16 | 2438 | 26 | 2458 | 36 | 2478 |
| 08 | 2420 | 17 | 2440 | 27 | 2460 | 39 | 2480 |

3. Table for Filed Antenna

| Ant. | Antenna Brand | Antenna Model | Antenna Type | Connector | Gain (dBi) | NOTE |
|------|---------------|---------------|-----------------------------|-----------|--------------------------------|----------|
| A,B | N/A | N/A | Ant. A: PCB Ant. B: PIFA | N/A | Ant. A: 0 dBi Ant. B: 2 dBi | BLE ANT. |



2.2 DESCRIPTION OF THE TEST MODES

To investigate the maximum EMI emission characteristics generates from EUT, the test system was pre-scanning tested base on the consideration of following EUT operation mode or test configuration mode which possible have effect on EMI emission level. Each of these EUT operation mode(s) or test configuration mode(s) mentioned above was evaluated respectively.

| Worst Mode | Description |
|------------|----------------|
| Mode 1 | TX Mode (CH37) |
| Mode 2 | TX Mode (CH17) |
| Mode 3 | TX Mode (CH39) |

2.3 TEST CONDITIONS

The module was tested while in a continuous transmitter/receiver mode. The EUT was tuned to a low, middle, and high channel for all tests. For all test case pre/scans were completed in all Modes to determine worst case levels.

Power Supply Voltage Fluctuation Test

| Voltage Fluctuation Test | Normal Voltage |
|--------------------------|----------------|
| Input DC Power | 3.7 |



2.4 BLOCK DIGRAM SHOWING THE CONFIGURATION OF SYSTEM TESTED

Mode 1:

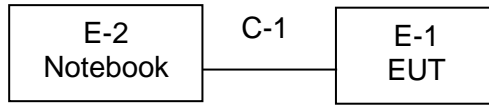

2.5 DESCRIPTION OF NECESSARY ACCESSORIES AND SUPPORT UNITS

The EUT has been tested as an independent unit together with other necessary accessories or support units. The following support units or accessories were used to form a representative test configuration during the tests.

Necessary accessories

| Item | Equipment | Mfr/Brand | Model/Type No. | Serial No. | Note |
|------|-----------|-----------|----------------|------------|------|
| N/A | N/A | N/A | N/A | N/A | N/A |
| | | | | | |
| | | | | | |
| | | | | | |
| | | | | | |

Support units

| Item | Equipment | Mfr/Brand | Model/Type No. | Serial No. | Note |
|------|-----------|-----------|----------------|------------|------|
| E-2 | Notebook | HP | 500-320cx | N/A | N/A |
| C-1 | USB Cable | N/A | 100cm | N/A | N/A |
| | | | | | |
| | | | | | |
| | | | | | |

Note:

- (1) The support equipment was authorized by Declaration of Confirmation.
- (2) For detachable type I/O cable should be specified the length in cm in 『Length』 column.
- (3) “YES” is means “shielded” “with core”; “NO” is means “unshielded” “without core”.



2.6 EQUIPMENTS LIST FOR ALL TEST ITEMS

Test equipment

| Kind of Equipment | Manufacturer | Type No. | Serial No. | Last calibration | Calibrated until |
|-------------------------------------|--------------|----------|---------------|------------------|------------------|
| USB RF power sensor | DARE | RPR3006W | 15I00041SNO03 | 2018.10.13 | 2019.10.12 |
| Signal Generator | Agilent | N5182A | MY46240556 | 2018.10.16 | 2019.10.15 |
| Signal Analyzer | Agilent | N9020A | MY49100060 | 2018.10.13 | 2019.10.12 |
| Wireless Communications Test Set | R&S | CMW 500 | 133884 | 2019.03.02 | 2020.03.01 |
| Temperature & Humidity | HH660 | Mieo | N/A | 2018.10.11 | 2019.10.10 |
| Temperature & Humidity test chamber | Safety test | GDS-250 | 171200018 | 2019.03.02 | 2020.03.01 |
| programmable power supply | Agilent | E3642A | MY40002025 | 2018.10.13 | 2019.10.12 |
| Attenuator | HP | 8494B | DC-18G | 2018.05.07 | 2019.05.06 |

Test Equipment Calibration

All of the test equipment is effective use and calibration certification institution, GRGT, the address is 163 tianhe district in huangpu road xiping cloud road .Guangzhou, China

3. CONSTRUCTION PROTECTION CONFIRMATION

Our products apply for Japanese radio frequency (rf) certification. The RF IC is sheided by the shieding cover which is welded on the PCB, it can't be removed easily.

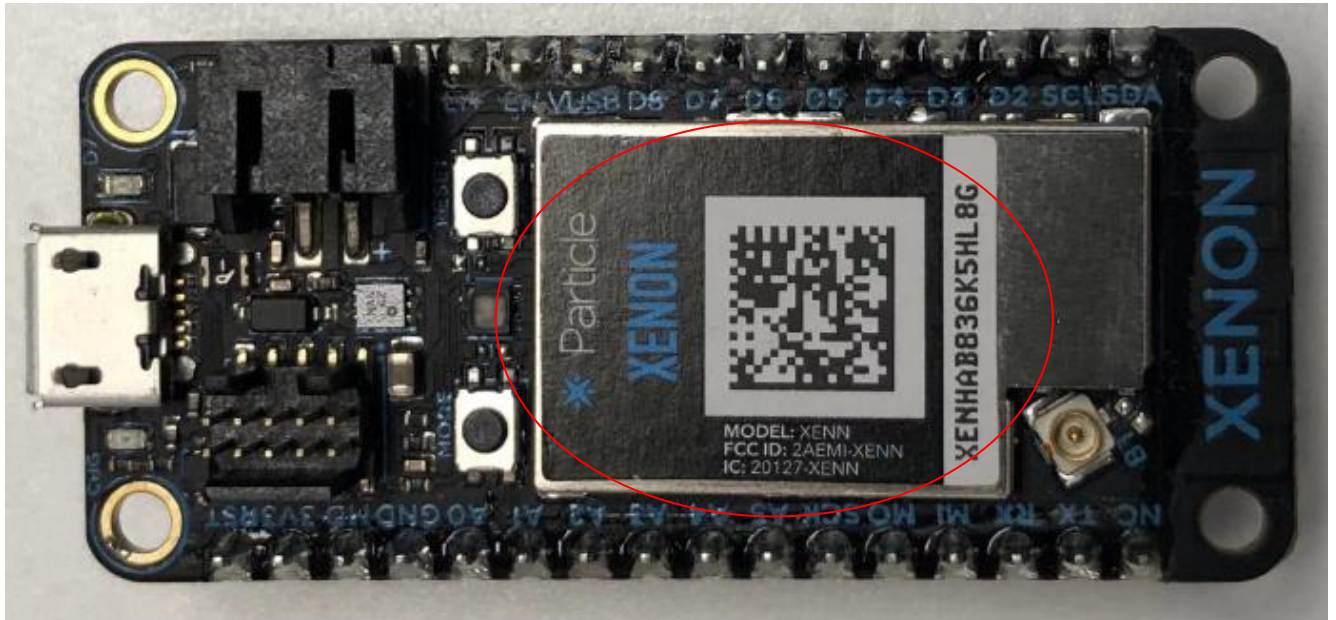

4. FREQUENCY ERROR

4.1 LIMIT

| Item | Limits |
|-----------------|---------|
| Frequency Error | ± 50ppm |

4.2 TEST PROCEDURES

The following table is the setting of Spectrum Analyzer.

| Spectrum Parameter | Setting |
|--------------------|----------|
| Attenuation | Auto |
| RB / VB | 10KHz |
| Detector | Peak |
| Trace | Max Hold |
| Sweep Time | Auto |

- (1) In the case of unmodulated signal (continuous or continuous burst), measure the frequency directly by a frequency meter.
- (2) In the case of burst waves, the measurement shall be done for enough time in order to obtain the enough measuring accuracy, and the average of the measured values becomes the final value.
- (3) In the case of a test mode with a specific frequency spectrum, measure the frequency of the specific spectrum by a spectrum analyzer.
- (4) In the cases above, if the frequency equivalent to the test frequency is not directly measured in principle, it shall be obtained by necessary calculation.

In the case of modulated signal, if there is no specific spectrum measurable by a spectrum analyzer but a specific dip is observed, it is allowed to measure the frequency with the signal generator (synthesized). That is, observe a signal of the signal generator concurrently (or alternately) with the tested signal using the spectrum analyzer while setting the frequency of the signal generator to the position of the dip on the screen of the spectrum analyzer, and determine the frequency of the signal generator at the time as a measured value.

4.3 TEST SETUP

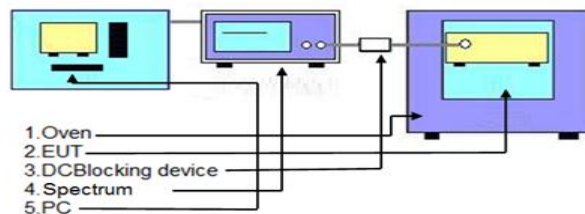

4.4 EUT OPERATION DURING TEST

The EUT was placed on the test table and programmed in un-modulation function.



4.5 TEST RESULT

Note: Antenna B power > Antenna A power, Antenna A, Antenna B all has been tested, Antenna A, Antenna B cannot transmit of the same time, only shown the worst case of Antenna B.

| | | | |
|-----------------|---------|-----------|---------|
| Temperature: | 25°C | Humidity: | 55 % RH |
| Operation Mode: | TX mode | | |

Antenna B

| TEST CONDITIONS | | Channel | F _c | Tolerance | Limit |
|-----------------|-----|---------|----------------|-----------|-------|
| | | MHz | MHz | ppm | (ppm) |
| V nom (V) | 3.7 | 2402 | 2401.9910 | -3.747 | ±50 |
| | | 2440 | 2439.9910 | -3.689 | ±50 |
| | | 2480 | 2479.9905 | -3.831 | ±50 |





CH39 Worst Mode

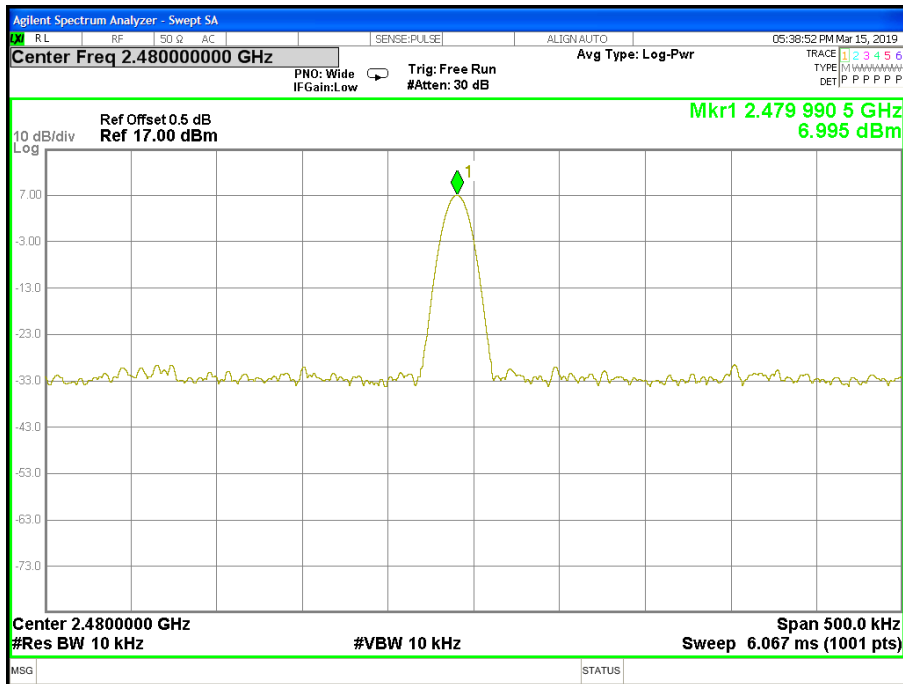

5. ANTENNA POWER

5.1 LIMIT

| Item | Limits |
|-----------------------|--|
| Antenna Power Density | $\leq 3\text{mW/MHz}$ (FH form 2400 – 2483.5 MHz) $\leq 10\text{mW/MHz}$ (OFDM,DS from2400~2483.5MHz,802.11b/g/n HT20) $\leq 5\text{mW/MHz}$ (OFDM,DS from2400~2483.5MHz,802.11n HT40) $\leq 10\text{mW}$ (Other from 2400~2483.5MHz) |
| Power Error | +20%, -80% (Base on manufacturer declare power) |

5.2 TEST PROCEDURE

1. EUT turn to test frequency channel and keep continuous transmitting
2. Reading the output power from the Power meter as P_{EUT}
3. Turn the Signal generator to frequency channel the same as the EUT
4. Turn the level of Signal generator, scan with the power meter until the power equal to P_{EUT} , the level of Signal generator recorded as "P"
5. The antenna power of EUT is "P".
6. EIRP power="P"+antenna gain

5.3 TEST SETUP

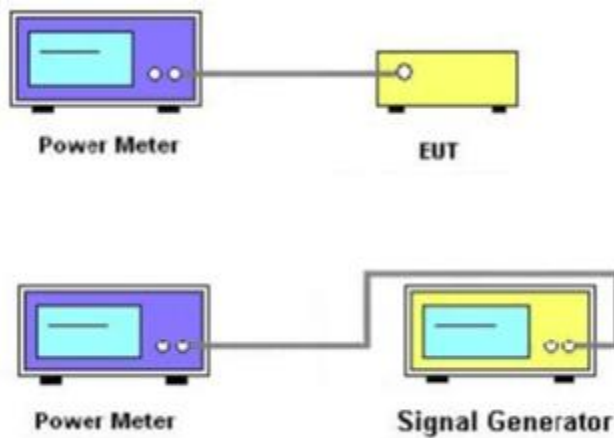

5.4 TEST DEVIATION

There is no deviation with the original standard.



5.5 TEST RESULT

| | | | |
|-----------------|---------|-----------|---------|
| Temperature: | 25°C | Humidity: | 55 % RH |
| Operation Mode: | TX mode | | |

Antenna Power Density

Antenna A:

| TEST CONDITIONS | | Channel (MHz) | Ant output POWER (dBm) | Ant output (mW) | Declared Power (mW) | Tolerance |
|--|-----|---------------|------------------------|-----------------|---------------------|-----------|
| | | % | | | | |
| Vnom(V) | 3.7 | 2402 | -1.7360 | 0.671 | 1.5000 | -55.30 |
| | | 2440 | 0.2490 | 1.059 | 1.5000 | -29.40 |
| | | 2480 | 0.0980 | 1.023 | 1.5000 | -31.81 |
| Limit : (1) Antenna Power Density Limit (10mW) (2) Tolerance +20%, -80% (Base on manufacturer declare Antenna Power Density) | | | | | | |

Antenna B:

| TEST CONDITIONS | | Channel (MHz) | Ant output POWER (dBm) | Ant output (mW) | Declared Power (mW) | Tolerance |
|--|-----|---------------|------------------------|-----------------|---------------------|-----------|
| | | % | | | | |
| Vnom(V) | 3.7 | 2402 | 6.9740 | 4.982 | 6.0000 | -16.97 |
| | | 2440 | 7.1280 | 5.162 | 6.0000 | -13.97 |
| | | 2480 | 7.0220 | 5.037 | 6.0000 | -16.04 |
| Limit : (1) Antenna Power Density Limit (10mW) (2) Tolerance +20%, -80% (Base on manufacturer declare Antenna Power Density) | | | | | | |



6. RADIATION POWER

6.1 LIMIT

| Item | Limits |
|----------------------|---|
| Radiation power EIRP | FH form 2400 – 2483.5 MHz ,EIRP \leq 6.91dBm/MHz CCK/OFDM/DBPSK (2400~2483.5MHz) OFDM or DS other than (802.11b/g/n HT20) EIRP \leq 12.14 dBm/MHz OFDM or DS other than (802.11n HT40) EIRP \leq 9.13dBm/MHz Other from 2400~2483.5MHz: 12.14 dBm or less |
| Power Error | +20%, -80% (Base on manufacturer declare power) |

6.2 TEST RESULT

Note: The antenna gain is less than 2.14dBi, no requirement.



7. OCCUPIED BANDWIDTH AND SPREAD BANDWIDTH

7.1 LIMIT

| Item | Limits |
|----------------------|--|
| Occupied Band Width: | $\leq 83.5\text{MHz}$ (FH;FH+DS;FH+OFDM) $\leq 26\text{MHz}$ (Others) |
| Spreading Bandwidth: | $\geq 500\text{ kHz}$ |

7.2 TEST PROCEDURES

- Setting of SA is following as: RB: 100KHz / VB:100KHz / SPAN: 2MHz / AT: 20dB Ref:10dBm / Sweep time: Auto / Sweep Mode: Continuous sweep / Detect mode: Positive peak / Trace mode: Max hold
- EUT have transmitted the maximum modulation signal and fixed channelize (For DSSS or OFDM Device) or continuous maximum power of hopping mode(For FHSS Device). SA set to 99% of occupied bandwidth to measure occupied bandwidth. The limit is less than 26MHz(For DSSS or OFDM Device) or 83.5MHz(For FHSS Device).
- SA set to 90% of occupied bandwidth to measure Spread Spectrum Bandwidth and must greater than 500kHz.

7.3 TEST SETUP

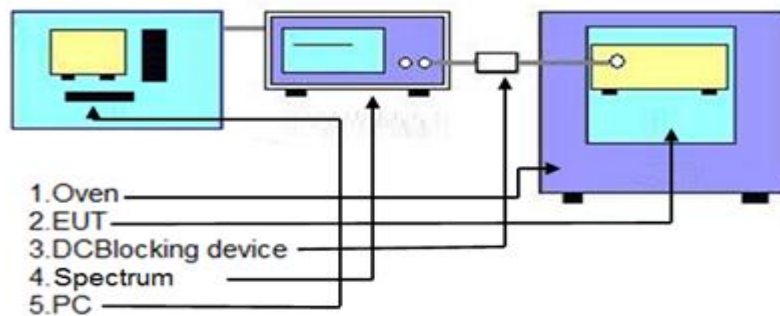

7.4 TEST DEVIATION

There is no deviation with the original standard.

7.5 EUT OPERATION DURING TEST

The EUT was programmed to be in continuously transmitting mode.



7.6 TEST RESULT

Note: Antenna B power > Antenna A power, Antenna A, Antenna B all has been tested, Antenna A, Antenna B cannot transmit of the same time, only shown the worst case of Antenna B.

| | | | |
|-----------------|---------|-----------|---------|
| Temperature: | 25°C | Humidity: | 55 % RH |
| Operation Mode: | TX mode | | |

Antenna B

| DC Voltage | | channel (MHz) | Occupied Bandwidth (MHz) | Spread Bandwidth (MHz) |
|----------------|-----|---------------|--------------------------|------------------------|
| Nor Voltage(V) | 3.7 | 2402 | 1.0705 | 0.698 |
| | | 2440 | 1.0698 | 0.700 |
| | | 2480 | 1.0740 | 0.704 |





CH37-Occupied Bandwidth (99%) Worst Mode

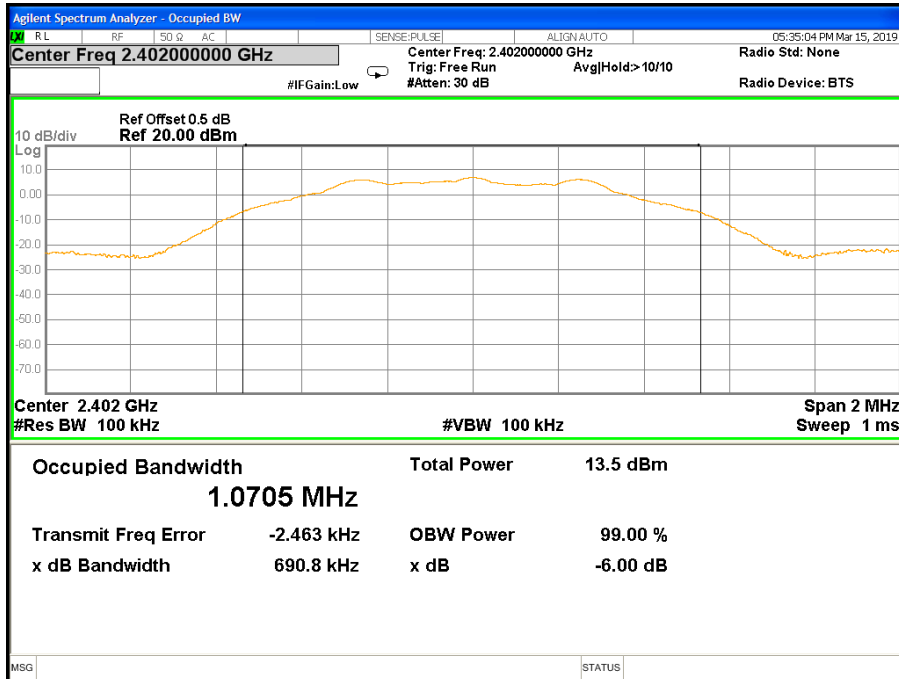

CH37-Spread Bandwidth (90%) Worst Mode

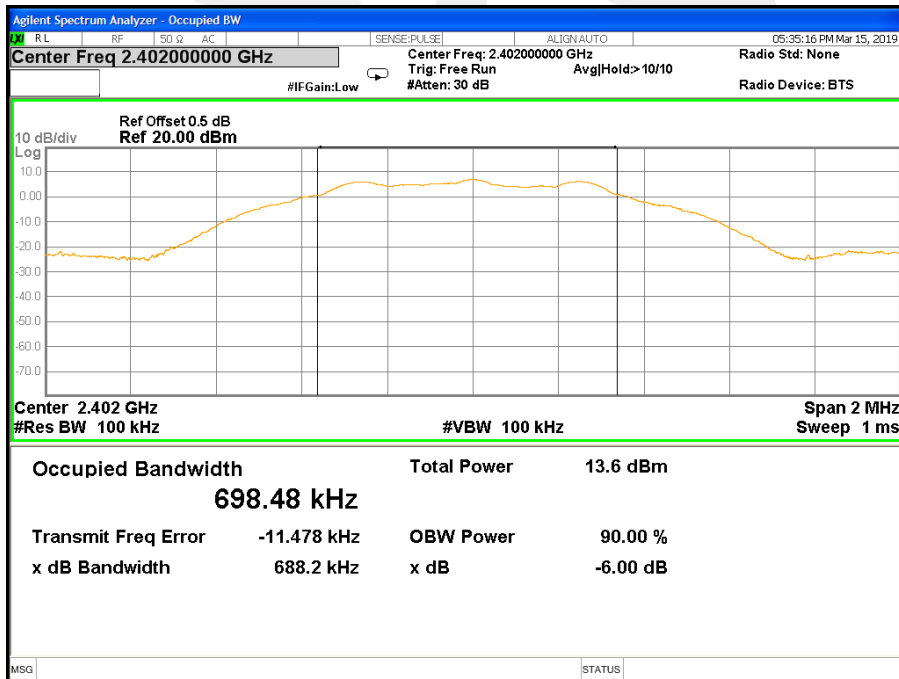



CH17-Occupied Bandwidth (99%) Mode Worst Mode

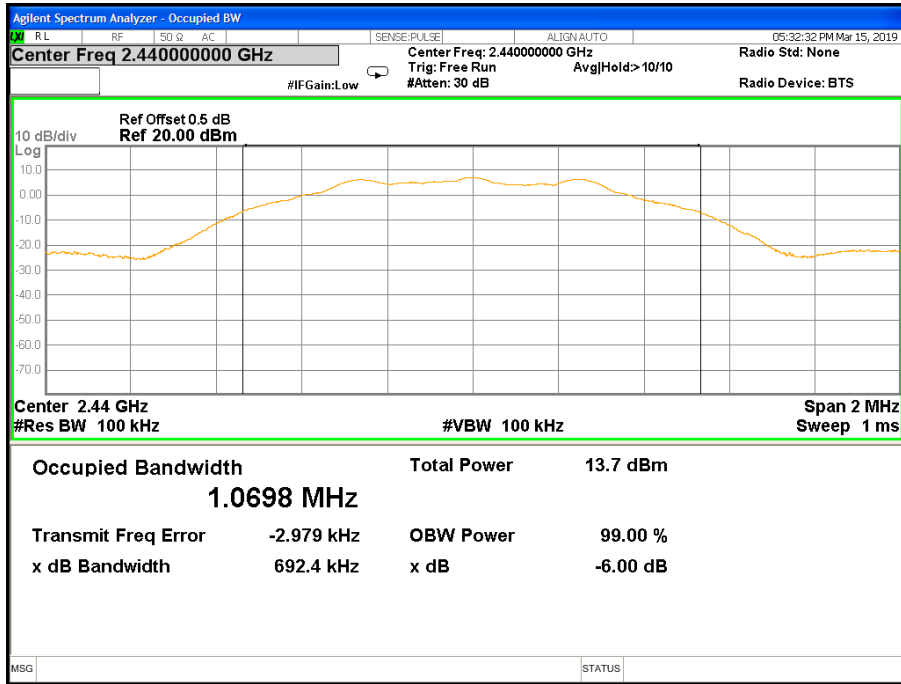

CH17-Spread Bandwidth (90%) Mode Worst Mode

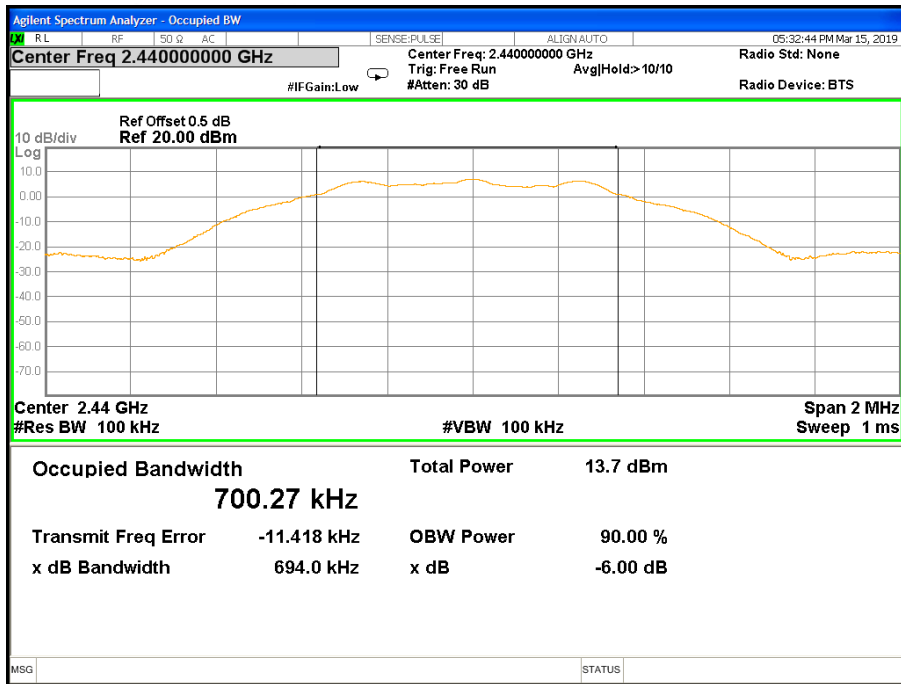



CH39-Occupied Bandwidth (99%) Worst Mode

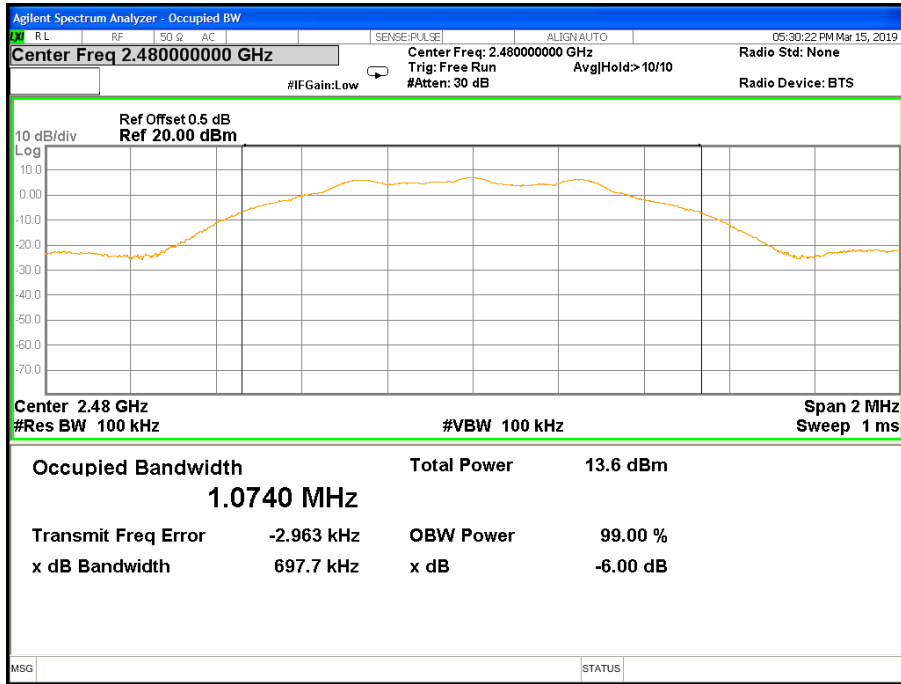

CH39-Spread Bandwidth (90%) Worst Mode

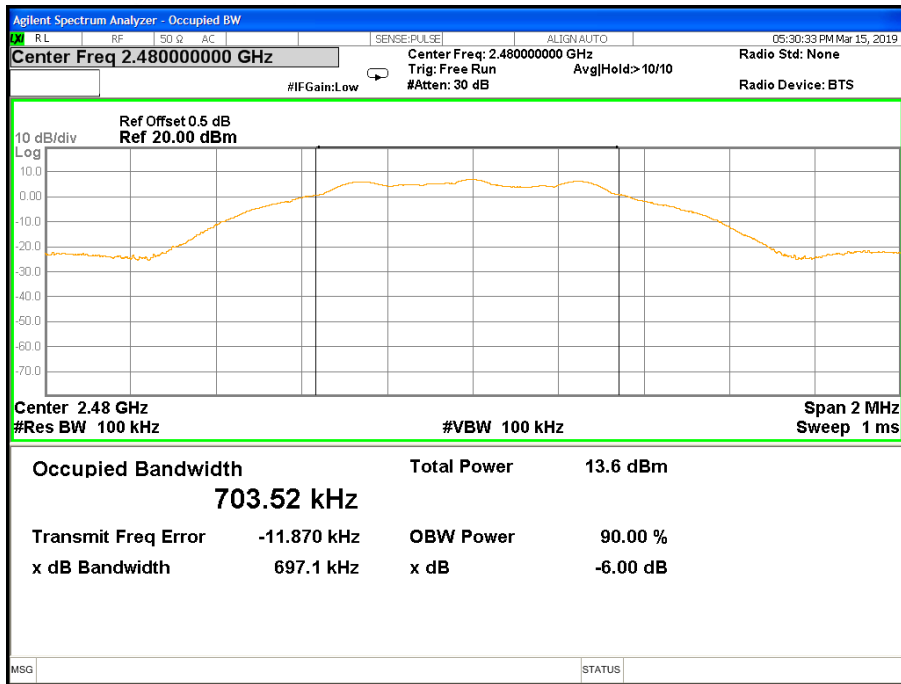



8. UNWANTED EMISSION INTENSITY MEASUREMENT

8.1 LIMIT

| Item | Limits |
|----------------------|--|
| TX Spurious Emission | $\leq 2.5 \mu\text{W}$ ($30\text{MHz} \leq f \leq 1000\text{MHz}$) |
| | $\leq 2.5 \mu\text{W}$ ($1000\text{MHz} < f \leq 2387\text{MHz}$) |
| | $\leq 25 \mu\text{W}$ ($2387\text{MHz} < f \leq 2400\text{MHz}$) |
| | $\leq 25 \mu\text{W}$ ($2483.5\text{MHz} \leq f < 2496.5\text{MHz}$) |
| | $\leq 2.5 \mu\text{W}$ ($2496.5\text{MHz} \leq f < 12500\text{MHz}$) |

8.2 TEST PROCEDURES

| Spectrum Parameter | Setting |
|--------------------|------------------------------|
| Attenuation | Auto |
| RB / VB | 100KHz / 100KHz (Below 1GHz) |
| RB / VB | 1MHz / 1MHz (Above 1GHz) |
| Detector | Peak |
| Trace | Max Hold |
| Sweep Time | Auto |

- EUT have transmitted the maximum modulation signal and fixed channelize.
- Setting of SA is following as: Below 1GHz RB:100KHz / VB:100KHz
Above 1GHz RB:1MHz / VB:1MHz / AT: 10dB Ref: 0dBm / Sweep time: Auto
Sweep Mode: Continuous sweep / Detect mode: Positive peak
Trace mode: Max hold
- Setting of SA is following as 30MHz and stop frequency 1000MHz Then to mark peak reading value + cable loss shall be less than 0.25 μW .
- Setting of SA is following as 1000MHz and stop frequency 2387MHz Then to mark peak reading value + cable loss shall be less than 2.5 μW .
- SA adjusted to start frequency 2387MHz and stop frequency 2400MHz. Then to mark peak reading value + cable loss shall be less than 25 μW .
- SA adjusted to start frequency 2483.5MHz and stop frequency 2496.5MHz Then to mark peak reading value + cable loss shall be less than 25 μW
- SA adjusted to start frequency 2496.5MHz and stop frequency 12750MHz Then to mark peak reading value + cable loss shall be less than 2.5 μW
- Measure side band spurious as follows: For 2.4GHz band: 2374MHz~2400MHz and 2483.5MHz~2509.5MHz RBW = VBW = 30kHz, Result_Value = Measured_Value + 15.2 [dBm]
- If the Result_Value is over the requirement, take total sum of 1MHz band centered at the spur frequency like ACLP measurement as Result_Value.

8.3 TEST SETUP

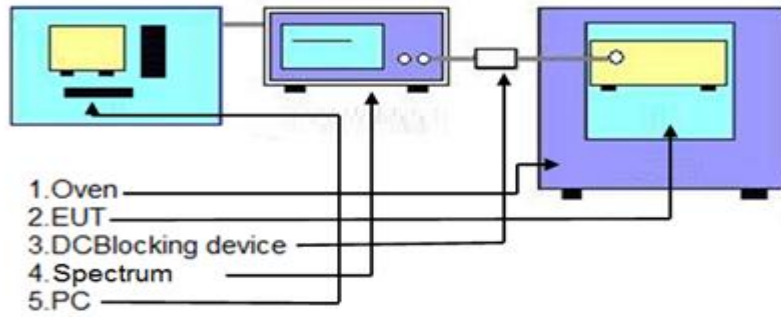

8.4 TEST DEVIATION

There is no deviation with the original standard.





8.5 TEST RESULT

Note: Antenna B power > Antenna A power, Antenna A, Antenna B all has been tested, Antenna A, Antenna B cannot transmit of the same time, only shown the worst case of Antenna B.

| | | | |
|--------------|--------------|-----------------|---------|
| Temperature: | 25°C | Humidity: | 55 % RH |
| Test Voltage | Nor. Voltage | Operation Mode: | TX mode |

Antenna B

CH 37 (TX mode) - Frequency Band 1 (30 MHz ≤ f ≤ 1000 MHz)

Worst Mode

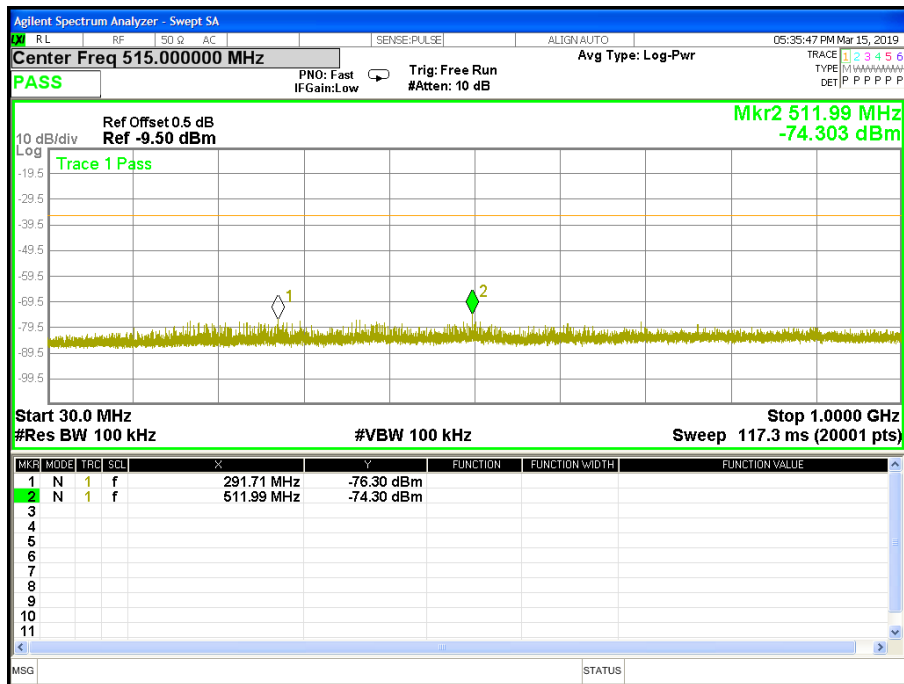



CH 37 TX mode - Frequency Band 2 (1000 MHz < f ≤ 2520 MHz) Worst Mode

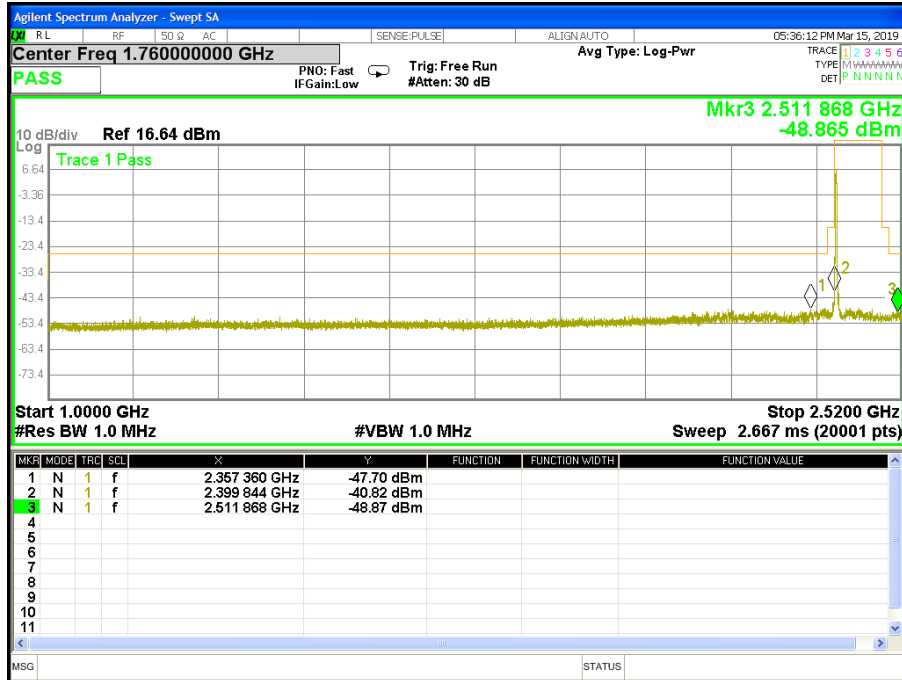

CH 37 TX mode - Frequency Band 3 (2520 MHz ≤ f < 12.75 GHz) Worst Mode

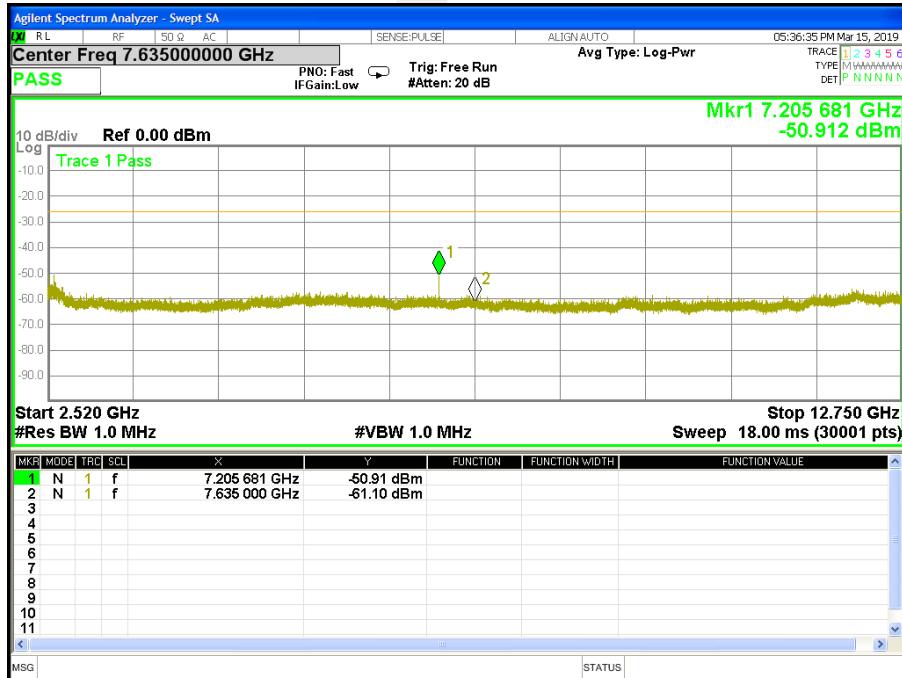



**CH 17 TX mode - Frequency Band 1 (30 MHz ≤ f ≤ 1000 MHz)
Worst Mode**

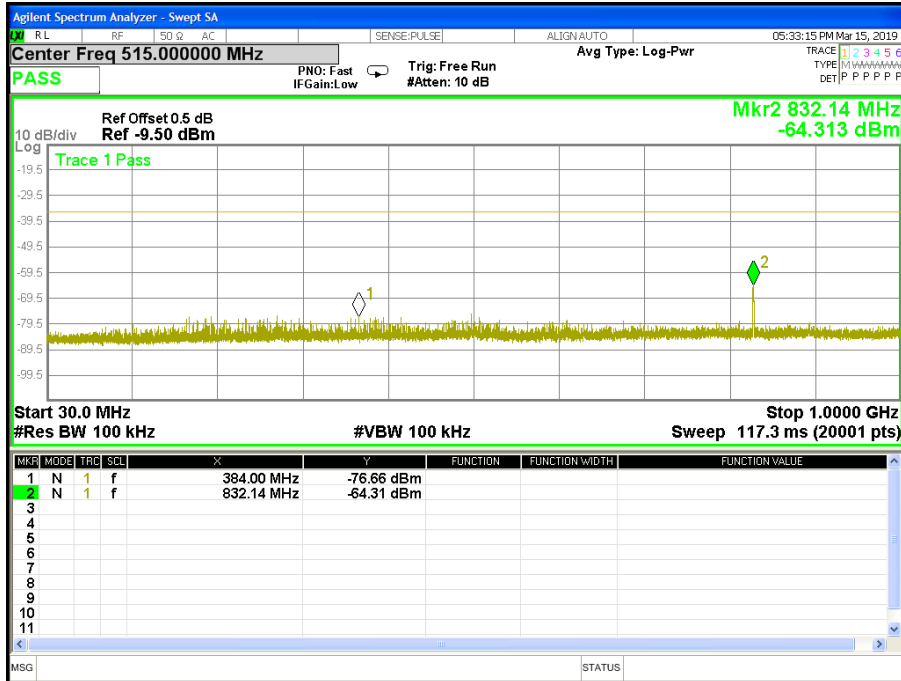

**CH 17 TX mode - Frequency Band 2 (1000 MHz < f ≤ 2520 MHz)
Worst Mode**

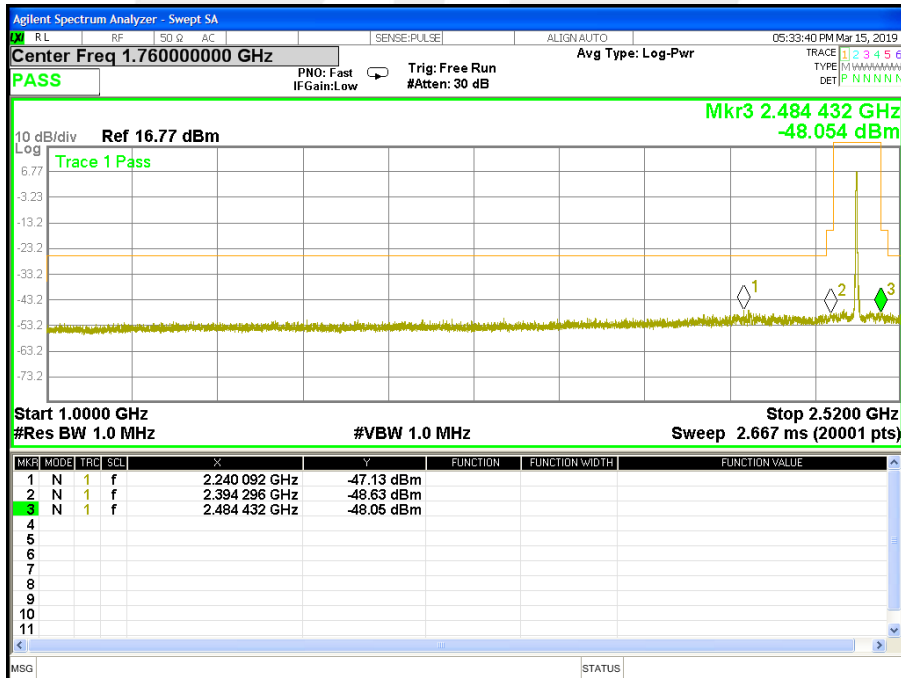



CH 17 TX mode - Frequency Band 3 (2520 MHz ≤ f < 12.75 GHz)
Worst Mode

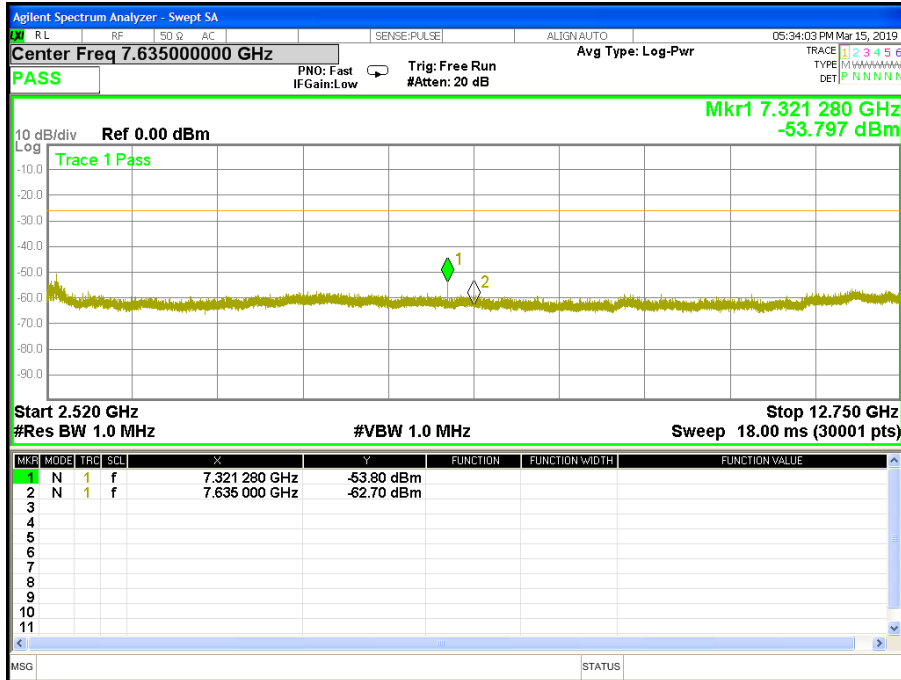

CH 39 TX mode - Frequency Band 1 (30 MHz ≤ f ≤ 1000 MHz)
Worst Mode

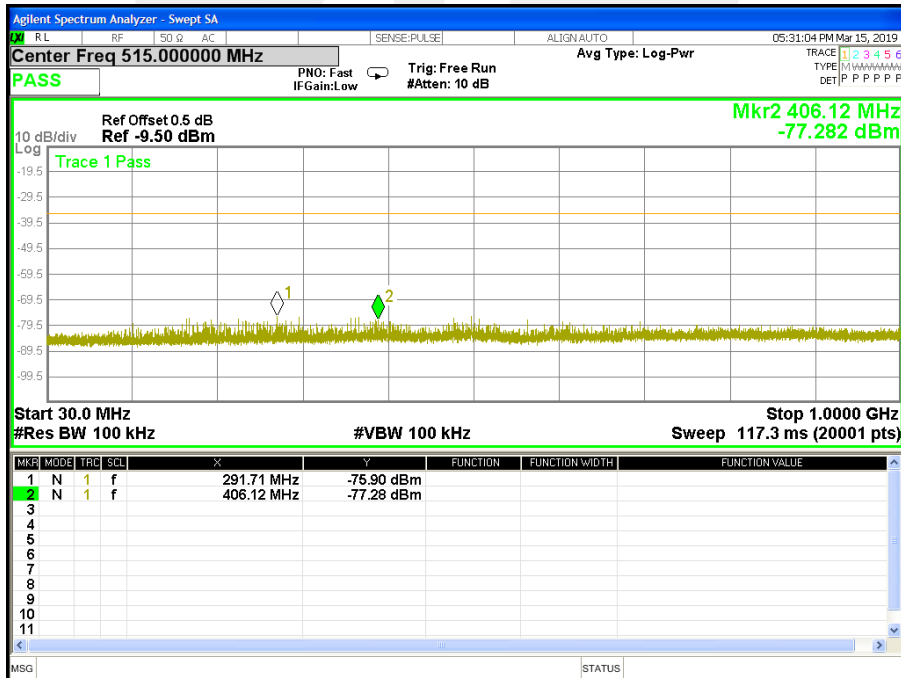



CH 39 TX mode - Frequency Band 2 (1000 MHz $\leq f \leq 2520\text{ MHz}$) Worst Mode

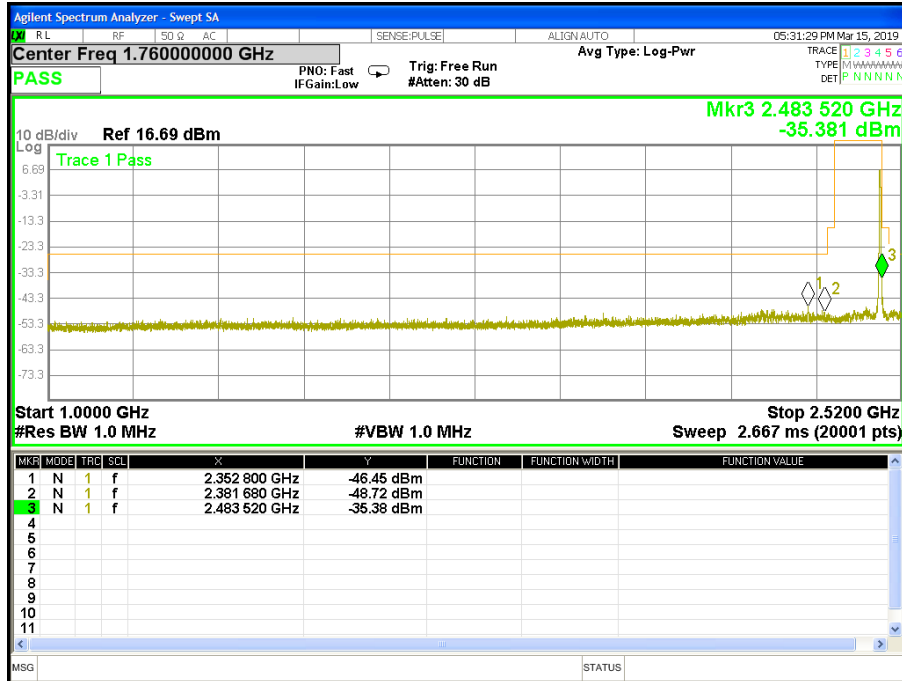

CH 39 TX mode - Frequency Band 3 (2520 MHz <math>\leq f < 12.75\text{ GHz}</math>) Worst Mode

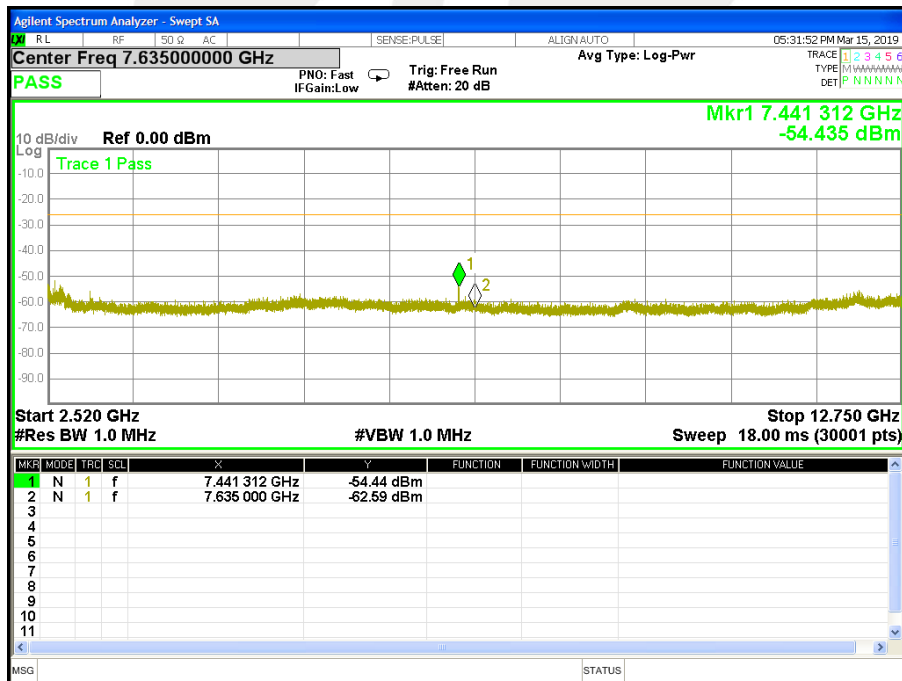



9. IMITATION OF COLLATERAL EMISSION OF RECEIVER MEASUREMENT

9.1 LIMIT

| Item | Limits |
|-----------------------|---|
| RX Spurious Emission: | $\leq 4\text{nW}$ ($f < 1\text{GHz}$) |
| | $\leq 20\text{nW}$ ($1\text{GHz} \leq f$) |

9.2 TEST PROCEDURES

The following table is the setting of Spectrum Analyzer.

| Spectrum Parameter | Setting |
|--------------------|--|
| Attenuation | Auto |
| RB | 100 kHz (below 1GHz emissions) 1 MHz (above 1GHz emissions) |
| VB | 100 kHz (below 1GHz emissions) 1 MHz (above 1GHz emissions) |
| Detector | Peak |
| Trace | Max Hold |
| Sweep Time | Auto |

1. EUT have the continuous reception mode and fixed only one channelize.
2. Setting of SA is following as RB / VB: 100 kHz (below 1GHz emissions) / 1 MHz (above 1GHz emissions) /
AT: 10dB / Ref: 0dBm / Sweep time: Auto / Sweep Mode: Continuous sweep / Detect mode: Positive peak / Trace mode: Max hold
3. SA set RB: 100kHz and VB: 100kHz. Then adjust to start frequency 30MHz and stop frequency 1000MHz. Search to mark peak reading value + cable loss shall be less than 4nW
4. SA set RB: 1MHz and VB: 1MHz. Then adjust to start frequency 1000MHz and stop frequency 12750MHz. Search to mark peak reading value + cable loss shall be less than 20nW
5. If power level of lower emissions are more than 1/10 of limit (.0.4nW for $f < 1\text{GHz}$, 2nW for $f \geq 1\text{GHz}$), all those are to be indicated in the 2nd and 3rd lines. If others are 1/10 or less more of the limit, no necessary to be indicated.



9.3 TEST RESULT

Note: Antenna B power > Antenna A power, Antenna A, Antenna B all has been tested, Antenna A, Antenna B cannot transmit of the same time, only shown the worst case of Antenna B.

| | | | |
|-----------------|----------------------|-----------|---------|
| Temperature: | 25°C | Humidity: | 55 % RH |
| Operation Mode: | Nor. Voltage RX mode | | |

The worst test channel of all channels was showed as the follow:

RX-Frequency Band 1 (30 MHz ≤ f < 1000 MHz) Worst Mode

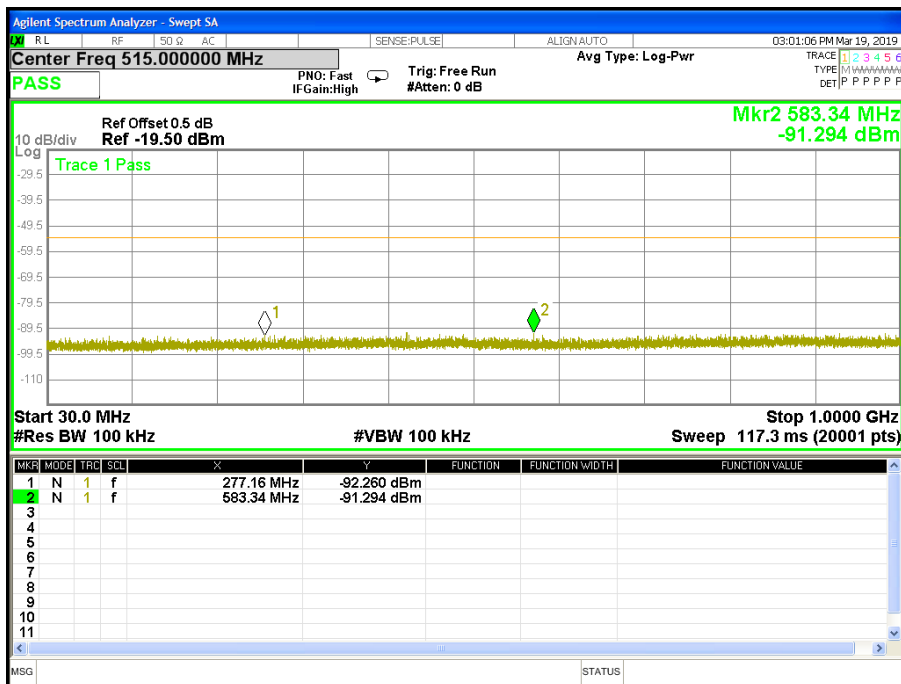

RX-Frequency Band 2 (1000 MHz ≤ f < 12750 MHz) Worst Mode

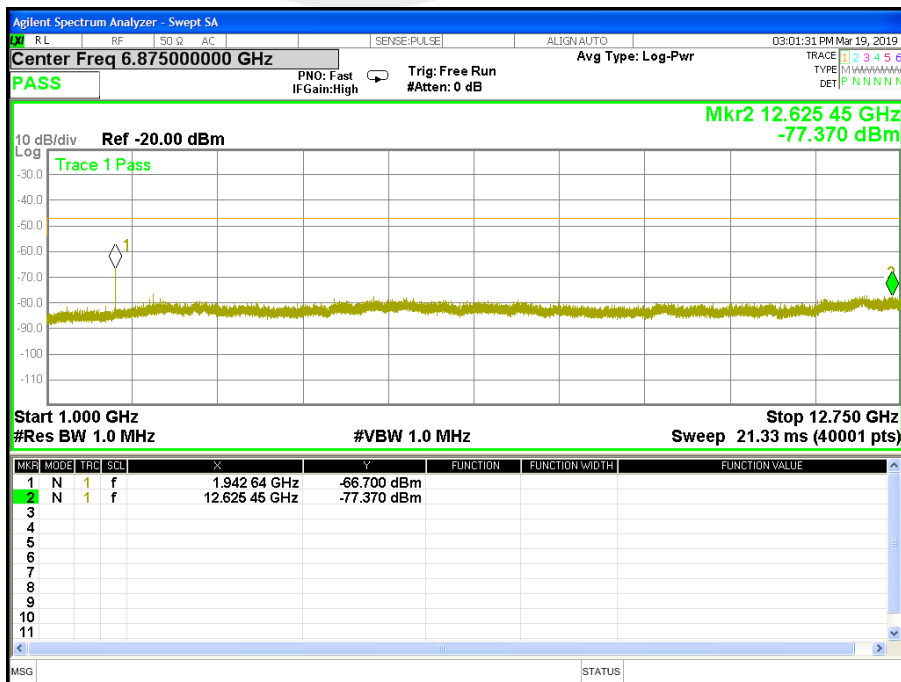



10. TRANSMISSION RADIATION ANGLE WIDTH (3DB BEAMWIDTH) MEASUREMENT

10.1 LIMIT

| Item | Limits |
|---|--|
| 3dB antenna beam width | $e \leq 360/A$ (The A is 10 in maximum) $A = \{EIRP \text{ Power [mW/MHz]} / \{2.14\text{dBi} + \text{output power}(10\text{mW /MHz}, 3\text{mW/MHz})\}\}$ Shall be 1 when A is lower than 1 |
| Note: This test item is not applied for radio equipment with equivalent isotropic radiation power lower than 12.14dBm/MHz, but Antenna Power(Conducted) limit is 10 mW/MHz (10 dBm/MHz), So the test item will not be applied to the transmission antenna which has a gain of 2.14dBi or less | |

10.2 TEST PROCEDURES

| Spectrum Parameter | Setting |
|--------------------|----------|
| Attenuation | Auto |
| Span Frequency | 0 MHz |
| RB | 1 MHz |
| VB | 1 kHz |
| Detector | Peak |
| Trace | Max Hold |
| Sweep Time | Auto |

1. Set EUT and measuring antenna at the same height and roughly facing each other.
2. Set spectrum analyzer with condition in section 4.7.2 and tune reference level to observe receiving signal position.
3. Rotate directions of the EUT horizontally and vertically to find the maximum receiving power.
4. Move the measuring antenna height up and down within $\pm 50\text{cm}$ of EUT height and swing it to find the maximum output of measuring antenna. "E" is the half-power beam width (angle between two points at which radiated power becomes 1/2)
5. Calculate permitted radiation angle in horizontal and vertical using EIRP measured in another test method.
6. Calculate 3dB antenna beam width by the formula below $360/A$ (If $A < 1$; then $A = 1$).
 $A = \{EIRP \text{ Power [mW/MHz]} / \{2.14\text{dBi} + \text{output power}(10\text{mW /MHz}, 3\text{mW/MHz})\}\}$
 Shall be 1 when A is lower than 1

10.3 TEST SETUP

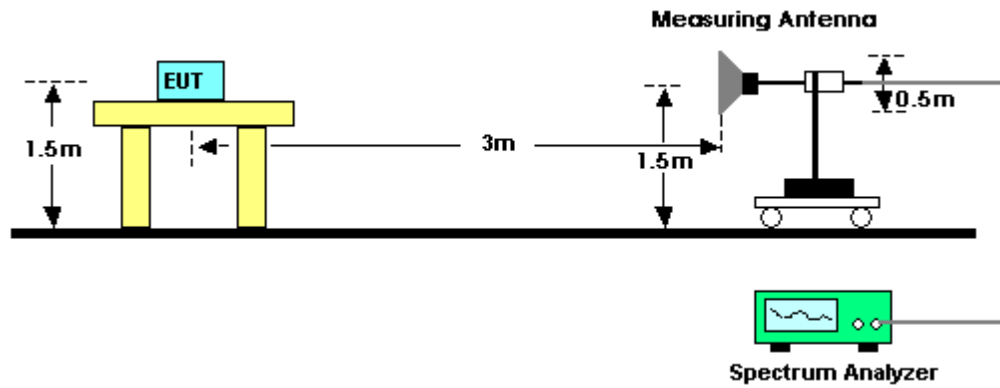

10.4 TEST DEVIATION

There is no deviation with the original standard.

10.5 EUT OPERATION DURING TEST

The EUT was programmed to be in continuously transmitting mode.

10.6 TEST RESULT

Note: The antenna gain is less than 2.14dBi, no requirement.

11. RADIO INTERFERENCE PREVENTION CAPABILITY MEASUREMENT

11.1 LIMIT

| Item | Limits |
|---------------------|----------------|
| Identification code | ≥ 48 bits |

11.2 MEASURING ID CODE SOFTWARE

| Item | Limits |
|-------------|----------|
| MAC IP List | MAC Scan |

11.3 TEST PROCEDURES

- In the case that the EUT has the function of automatically transmitting the identification code: a. Transmit the predetermined identification codes form EUT. b. Check the transmitted identification codes with the demodulator.
- In the case of receiving the identification ocde: a. Transmit the predetermined identification codes form the counterpart. b . Check if communication is normal. c. Transmit the signals other than predetermined ID codes form the counterpart. d. check if the EUT stops the transmission, or if it displays that idnetification codes are different from the predetermined ones.

11.4 TEST SETUP

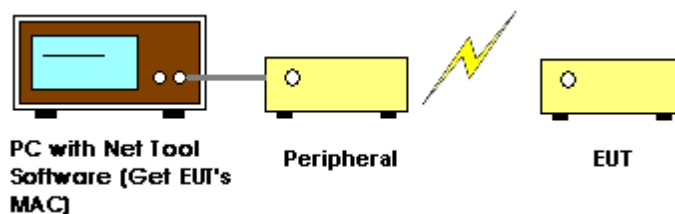

11.5 TEST DEVIATION

There is no deviation with the original standard.

11.6 EUT OPERATION DURING TEST

The EUT was programmed to be in normal transmitting mode.



11.7 TEST RESULT OF RADIO INTERFERENCE PREVENTION CAPABILIT

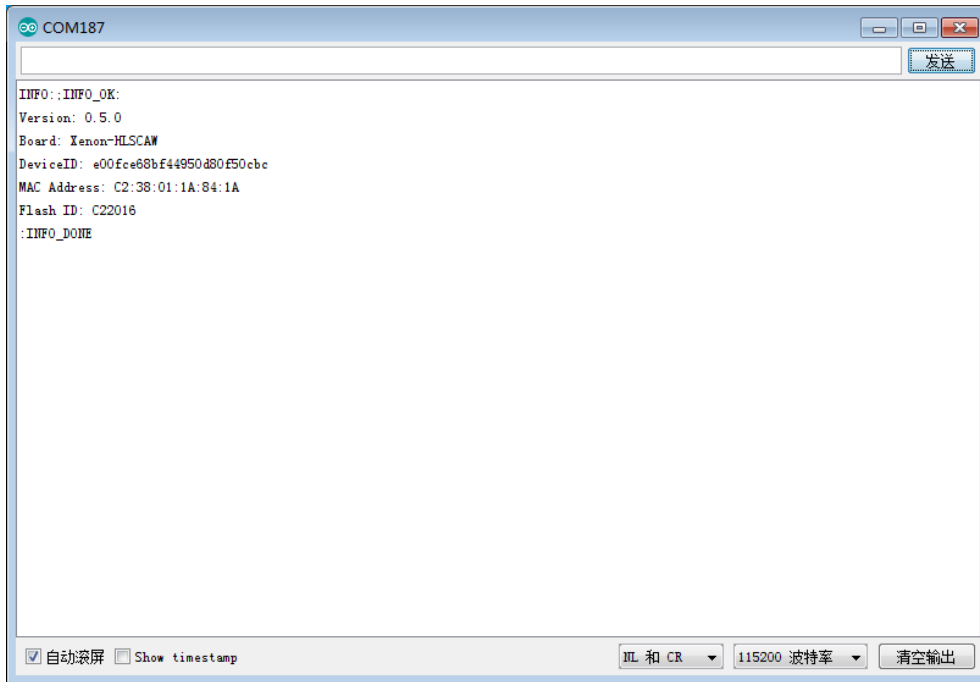

Note: The MAC Address is C2:38:01:1A:84:1A.

12. CARRIER SENSE CAPABILITY

12.1 INTERFERENCE PREVENTION FUNCTION

12.2 TEST REQUIREMENT

MIC Notice No.88 Appendix No.43

Article 2, Paragraph 1, Item 19 Rules Section 10

12.3 TEST PROCEDURE

1. SG adjusted the frequency as same as the EUT transmitted signal and emitted the absence of modulation from SG and power level is $(on\ 22.79+G-20*\log(f)\text{dBm})$ (G is the antenna gain, f is the test frequency).
2. turn off the RF signal of the SG.
3. EUT have transmitted the maximum modulation signal and fixed channelize.
4. Setting of SA :RBW/VBW=1MHz/1MHz, Span=50MHz, Sweep time=auto, Sweep mode=continuous, Detect mode=positive peak
5. SG RF signal on.
6. EUT shall be stop the transmitted any signal and SG RF signal off, the EUT will be continuous

❖ Measurement System Diagram

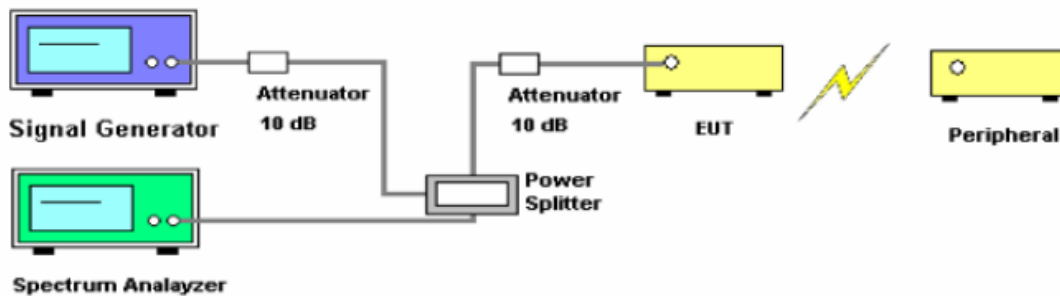

❖ Conditions of Application Equipment (EUT)

- The EUT state shall be “normal mode link with wireless router”.

12.4 TEST RESULT

Note: no requirement.



EUT TEST PHOTO

Note: See test photos in setup photo document for the actual connections between Product and support equipment.

※※※※END OF THE REPORT※※※※

